



HYDRA-MATIC 4L40-E/5L40-E

INDEX

[PREVIOUS](#)
[MENU](#)

GO TO PAGE

<i>5L40-E IDENTIFICATION TAG INFORMATION</i>	3
<i>CUT-AWAY VIEW AND COOLER LINE IDENTIFICATION</i>	4
<i>COMPONENT APPLICATION CHART</i>	5
<i>SOLENOID APPLICATION AND RESISTANCE CHARTS</i>	6
<i>INTERNAL WIRE SCHEMATIC</i>	7
<i>TCM LOCATION, CONNECTOR I.D. AND UNDERHOOD FUSE BLOCK I.D.</i>	8
<i>ELECTRONIC COMPONENT LOCATER</i>	10
<i>INTERNAL MODE SWITCH DESCRIPTION</i>	11
<i>DIAGNOSTIC TROUBLE CODES AND DESCRIPTION</i>	12
<i>GENERAL OPERATION AND DESCRIPTION</i>	14
<i>FLUID LEVEL CHECKING PROCEDURE</i>	15
<i>LINE PRESSURE TESTS</i>	16
<i>OIL PRESSURE PASSAGE IDENTIFICATIONS</i>	17
<i>CHECK BALL DESCRIPTIONS</i>	24
<i>TRANSMISSION DISASSEMBLY</i>	27
<i>TRANSMISSION EXPLODED VIEW</i>	30
<i>COMPONENT REBUILD SECTION</i>	
<i>CASE ASSEMBLY</i>	41
<i>OIL PUMP ASSEMBLY</i>	45
<i>DIRECT AND REVERSE CLUTCH HOUSING</i>	51
<i>FORWARD AND COAST CLUTCH HOUSING</i>	59
<i>FORWARD SPRAG ASSEMBLY</i>	67
<i>INTERMEDIATE SPRAG ASSEMBLY</i>	69
<i>INTERMEDIATE AND OVERDRIVE CLUTCH HOUSING</i>	76
<i>LOW SPRAG ASSEMBLY</i>	81
<i>CENTER SUPPORT ASSEMBLY</i>	84
<i>5L40-E PLANETARY CARRIER ASSEMBLY</i>	96
<i>4L40-E PLANETARY CARRIER ASSEMBLY</i>	99
<i>VALVE BODY ASSEMBLY</i>	102
<i>CHECKBALL LOCATIONS</i>	105
<i>FINAL TRANSMISSION ASSEMBLY</i>	108
<i>BOLT IDENTIFICATION CHART</i>	126
<i>TORQUE SPECIFICATIONS</i>	127

"Portions of materials contained herein have been reprinted with permission of General Motors Corporation, Service Operations."

AUTOMATIC TRANSMISSION SERVICE GROUP
9200 S. DADELAND BLVD. SUITE 720
MIAMI, FLORIDA 33156
(305) 670-4161

Copyright © ATSG 2002



INTRODUCTION

HYDRA-MATIC 4/5L40-E

*Published
July, 2002*

Beginning at the start of production for some 1999 models, BMW has introduced a new 5 speed automatic transmission that is designed and manufactured by General Motors Powertrain division in Strasbourg, France and is illustrated in Figure 1. This new transmission is designated as follows:

GM Designation - 5L40-E BMW Designation - A5S 360R

Model year 1999 applications are as follows:

3 Series BMW, with 2.5L Gasoline Engine, Used in USA and Japan.

3 Series BMW, with 2.8L Gasoline Engine, Used in USA and Japan.

5 Series BMW, with 3.0L Diesel Engine, Used Worldwide.

Model year 2003 applications are as follows:

Cadillac CTS model, Gasoline Engine, Used Worldwide

No part of any ATSG publication may be reproduced, stored in any retrieval system or transmitted in any form or by any means, including but not limited to electronic, mechanical, photocopying, recording or otherwise, without *written* permission of Automatic Transmission Service Group. This includes all text illustrations, tables and charts.

"Portions of materials contained herein have been reprinted with permission of General Motors Corporation, Service Operations."

The information and part numbers contained in this booklet have been carefully compiled from industry sources known for their reliability, but ATSG does not guarantee its accuracy.

Copyright © ATSG 2002

DALE ENGLAND
FIELD SERVICE CONSULTANT

WAYNE COLONNA
TECHNICAL SUPERVISOR

PETER LUBAN
TECHNICAL CONSULTANT

JON GLATSTEIN
TECHNICAL CONSULTANT

GERALD CAMPBELL
TECHNICAL CONSULTANT

ROLAND ALVAREZ
TECHNICAL CONSULTANT

JIM DIAL
TECHNICAL CONSULTANT

ED KRUSE
TECHNICAL CONSULTANT

GREGORY LIPNICK
TECHNICAL CONSULTANT

DAVID CHALKER
TECHNICAL CONSULTANT

JERRY GOTT
TECHNICAL CONSULTANT

STANTON ANDERSON
TECHNICAL CONSULTANT

AUTOMATIC TRANSMISSION SERVICE GROUP
9200 S. DADELAND BLVD. SUITE 720
MIAMI, FLORIDA 33156
(305) 670-4161



Technical Service Information

- 5 = 5 Forward Speeds
- L = Longitudinal (Rear Drive)
- 4 } = Relative Torque Capacity
- 0 }
- E = Electronic Controls

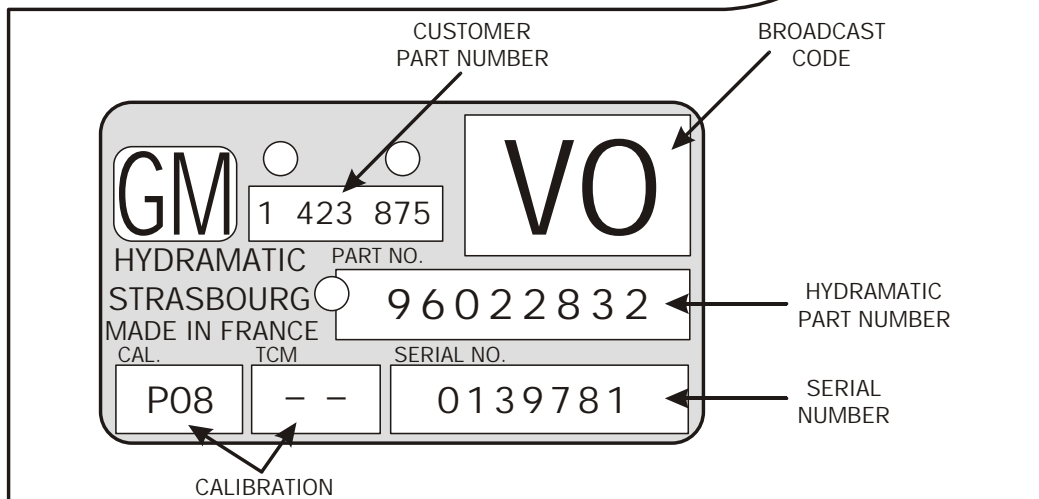
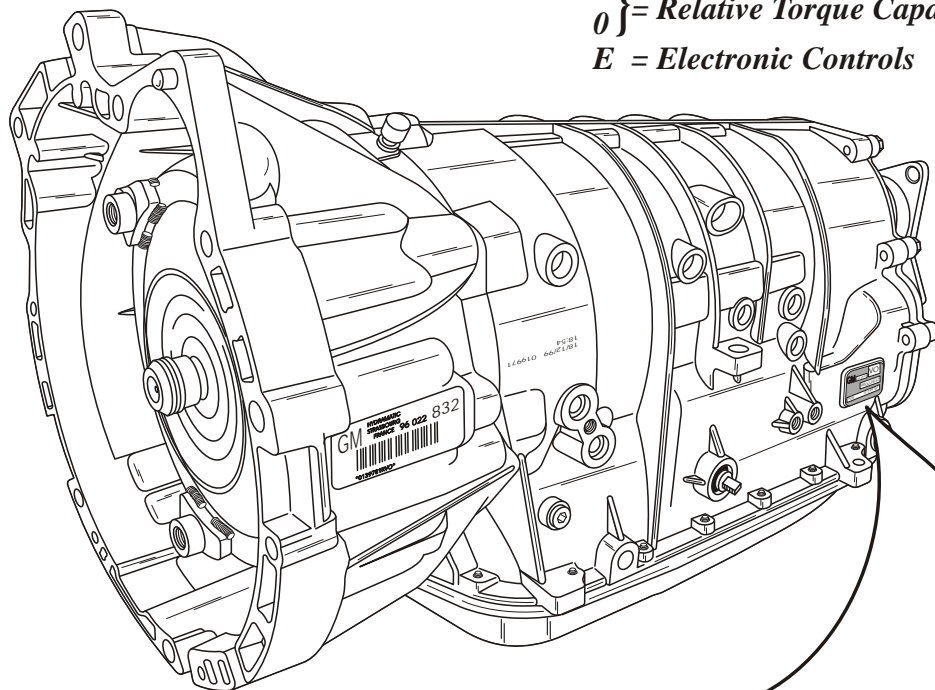

Production Location = Strasbourg, France
Torque Converter Size = 245mm and 258mm (Model Sensitive)
Pressure Taps = Line Pressure Only
Transmission Fluid Type = Dexron™ III
Transmission Fluid Capacity (Approx.) = Complete Overhaul: Dry 8.5L (9.0 Qt)

Figure 1



Technical Service Information

5L40-E CUT-AWAY VIEW AND COMPONENT LOCATIONS

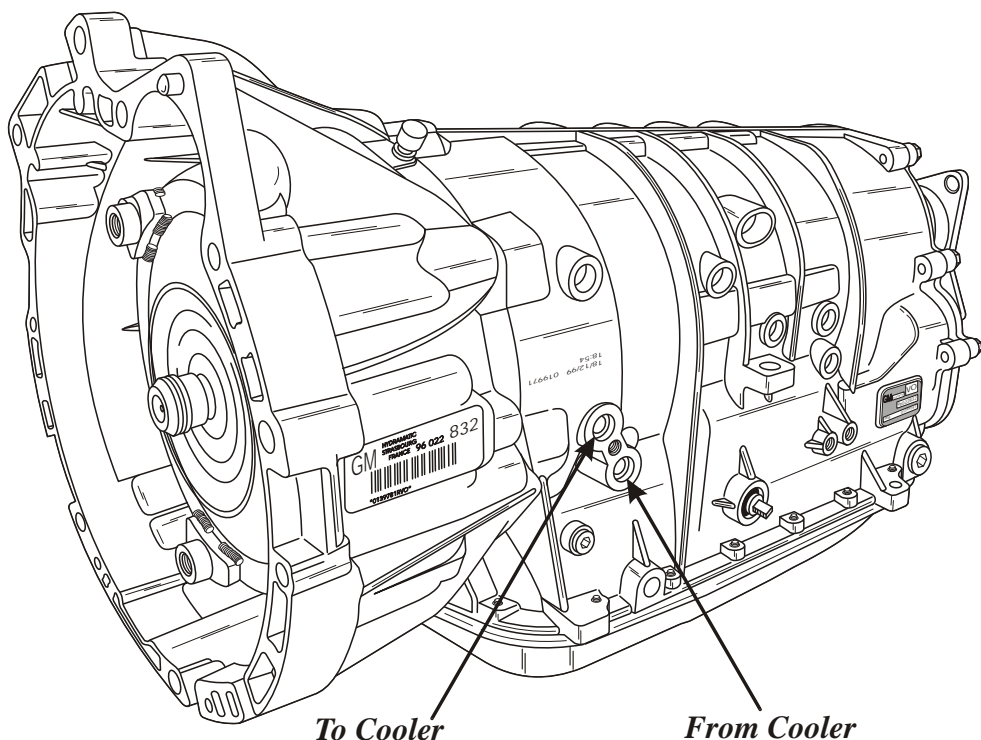
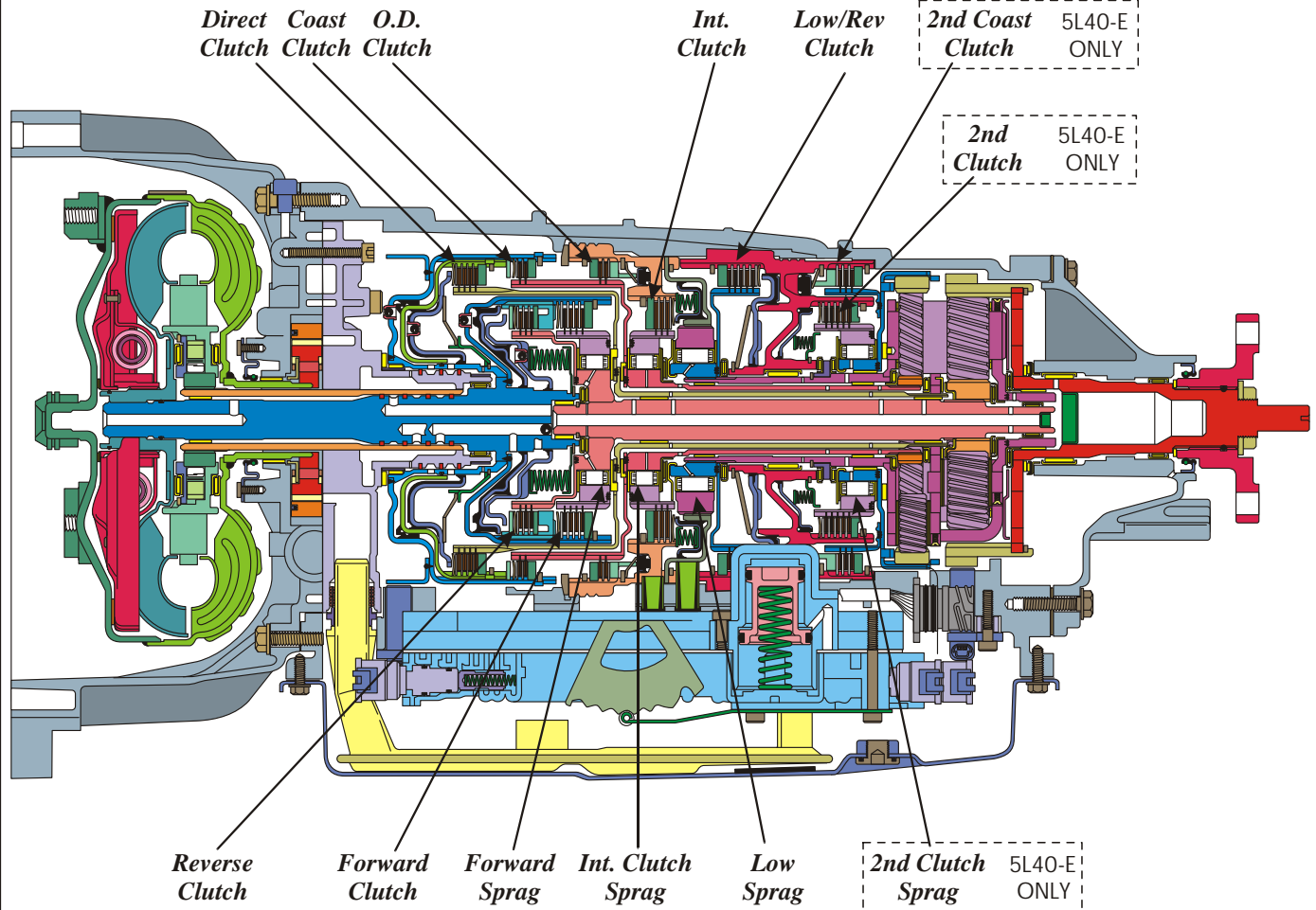

Copyright © 2002 ATSG

Figure 2



Technical Service Information

COMPONENT APPLICATION CHARTS

5L40-E COMPONENT APPLICATION CHART

RANGE	GEAR	Engine Braking	Direct Clutch	Coast Clutch	Reverse Clutch	Fwd. Clutch	2nd Clutch	Int. Clutch	O.D. Clutch	Low/Reverse Clutch	2nd Coast Clutch	Fwd. Clutch Sprag	Low Clutch Sprag	2nd Clutch Sprag	Int. Clutch Sprag	Gear Ratio
Park/Neutral																
Reverse	R	Yes			On					On						3.03
D, 4, 3, 2,	1st	No*		On		On						Hold	Hold			3.42
	1st	Yes		On		On				On		Hold	Hold			3.42
	2nd	No*		On		On	On					Hold		Hold		2.21
	2nd	Yes		On		On	On				On	Hold		Hold		2.21
	3rd	No*		On		On	On	On				Hold			Hold	1.60
	3rd	Yes		On		On	On	On	On			Hold			Hold	1.60
	4th	Yes	On	On			On	On	On			Hold				1.00
5th	Yes	On	On			On	On	On	On							0.75

* Engine braking is electronically controlled by the TCM, and is available as calibrated for each model and application.
On = Clutch Applied.

4L40-E COMPONENT APPLICATION CHART

RANGE	GEAR	Engine Braking	Direct Clutch	Coast Clutch	Reverse Clutch	Fwd. Clutch		Int. Clutch	O.D. Clutch	Low/Reverse Clutch		Fwd. Clutch Sprag	Low Clutch Sprag		Int. Clutch Sprag	Gear Ratio
Park/Neutral																
Reverse	R	Yes			On					On						3.03
D, 4, 3, 2,	1st	No*		On		On						Hold	Hold			2.82
	1st	Yes		On		On				On		Hold	Hold			2.82
	2nd	No*		On		On						Hold				1.54
	2nd	Yes		On		On						Hold				1.54
	3rd	No*		On		On		On				Hold			Hold	1.00
	3rd	Yes		On		On		On	On			Hold			Hold	1.00
	4th	Yes	On	On			On		On			Hold				0.70

* Engine braking is electronically controlled by the TCM, and is available as calibrated for each model and application.
On = Clutch Applied.

Copyright © 2002 ATSG

Figure 3



Technical Service Information

5L40-E SOLENOID APPLICATION CHART

RANGE	GEAR	Engine Braking	Direct Clutch	Coast Clutch	Reverse Clutch	Fwd. Clutch	2nd Clutch	Int. Clutch	O.D. Clutch	Low/Reverse Clutch	2nd Coast Clutch	1-2 Shift Sol.	2-3 Shift Sol.	4-5 Shift Sol.	TCC Sol.	Gear Ratio
Park/Neutral												***	***	***	Off	
Reverse	R	Yes			On					On		On			Off	3.03
D, 4, 3, 2,	1st	No*		On		On						Off	On	Off	Off	3.42
	1st	Yes		On		On				On		Off	On	On	Off	3.42
	2nd	No*		On		On	On					On	On	Off	On**	2.21
	2nd	Yes		On		On	On				On	On	On	On	On**	2.21
	3rd	No*		On		On	On	On				On	Off	Off	On**	1.60
	3rd	Yes		On		On	On	On	On			On	Off	On	On**	1.60
	4th	Yes	On	On		On	On	On				Off	Off	On	On**	1.00
5th	Yes	On				On	On	On	On			Off	Off	Off	On**	0.75

* Engine braking is electronically controlled by the TCM, and is available as calibrated for each model and application.

** Dependant upon various sensors including vehicle speed and throttle position.

*** Calibrated for particular model and application.

On = Clutch Applied.

On = Solenoid Energized.

Off = Solenoid De-Energized.

5L40-E COMPONENT RESISTANCE CHART

COMPONENT	CASE CONN TERMINALS	RESISTANCE @ 20°C (68°F)
1-2 Shift Solenoid "A" (On/Off - N/C)	14 And 17	15-17 Ohms
2-3 Shift Solenoid "B" (On/Off - N/C)	9 And 17	15-17 Ohms
4-5 Shift Solenoid "C" (On/Off - N/C)	5 And 17	15-17 Ohms
TCC Solenoid (PWM - N/C)	20 And 17	10.0-11.5 Ohms
Pressure Control Solenoid (PWM - N/C)	8 And 13	3.5-4.6 Ohms
Input Speed Sensor	18 And 15	325-485 Ohms
Output Speed Sensor	1 And 3	325-485 Ohms
Transmission Fluid Temperature Sensor	10 And 6	See Chart Below
Internal Mode Switch	See Wire Schematic	See Chart

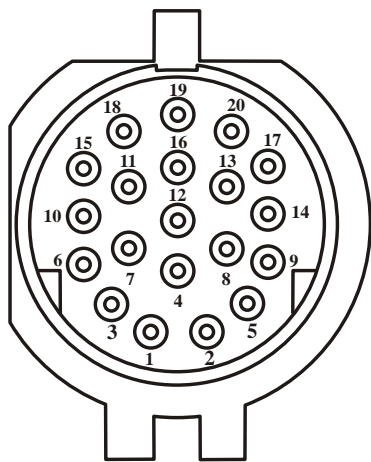

View Looking Into Transmission Case Connector

TFT Sensor Resistance Chart

Temperature C° (F°)	Resistance In Ohms		
	Minimum	Nominal	Maximum
-30C (-22F)	50264	52594	54924
-20C (-8F)	27439	28582	29725
-10C (14F)	15540	16120	16700
0C (32F)	9097	9399	9701
10C (50F)	5493	5658	5823
20C (68F)	3418	3511	3604
30C (86F)	2185	2240	2295
40C (104F)	1430	1465	1500
50C (122F)	958	980	1002
60C (140F)	656	671	686
70C (158F)	459	469	479
80C (176F)	327	334	341
90C (194F)	237	242	247
100C (212F)	174	178	182
110C (230F)	130	133	136
120C (248F)	98	101	104
130C (266F)	75	78	80

Figure 4



Technical Service Information

CADILLAC/BMW INTERNAL WIRE SCHEMATIC

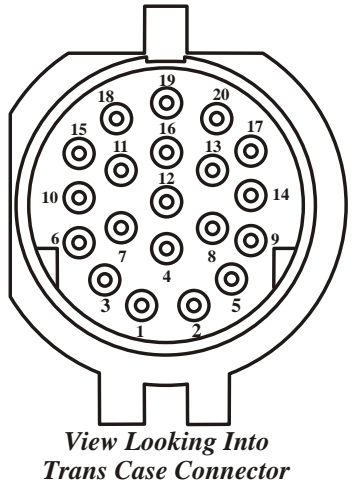
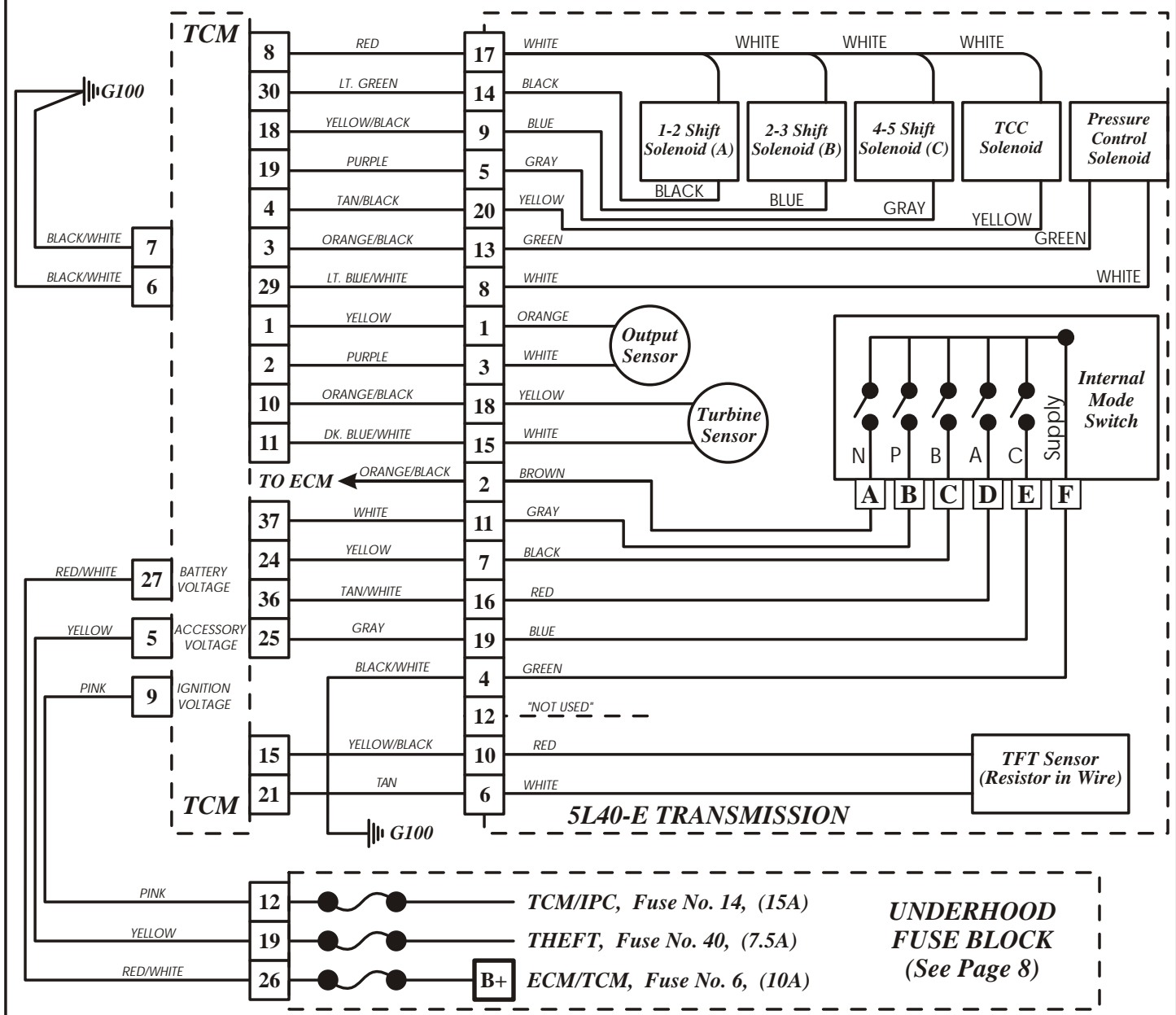

Pin No.	Description	Pin No.	Description
1	Output Speed Sensor (OSS) (+)	11	Internal Mode Switch Signal "P"
2	Internal Mode Switch Signal "N"	12	"Not Used"
3	Output Speed Sensor (OSS) (-)	13	Pressure Control Solenoid (+)
4	Internal Mode Switch Supply	14	1-2 Shift Solenoid (A) Ground
5	4-5 Shift Solenoid (C) Ground	15	Input Speed Sensor (ISS) (-)
6	Trans Fluid Temp (TFT) Sensor (-)	16	Internal Mode Switch Signal "A"
7	Internal Mode Switch Signal "B"	17	Solenoid Power In
8	Pressure Control Solenoid (-)	18	Input Speed Sensor (ISS) (+)
9	2-3 Shift Solenoid (B) Ground	19	Internal Mode Switch Signal "C"
10	Trans Fluid Temp (TFT) Sensor (+)	20	TCC/PWM Solenoid Ground

Copyright © 2002 ATSG

Figure 5



Technical Service Information

TRANSMISSION CONTROL MODULE (TCM) CONNECTOR IDENTIFICATION

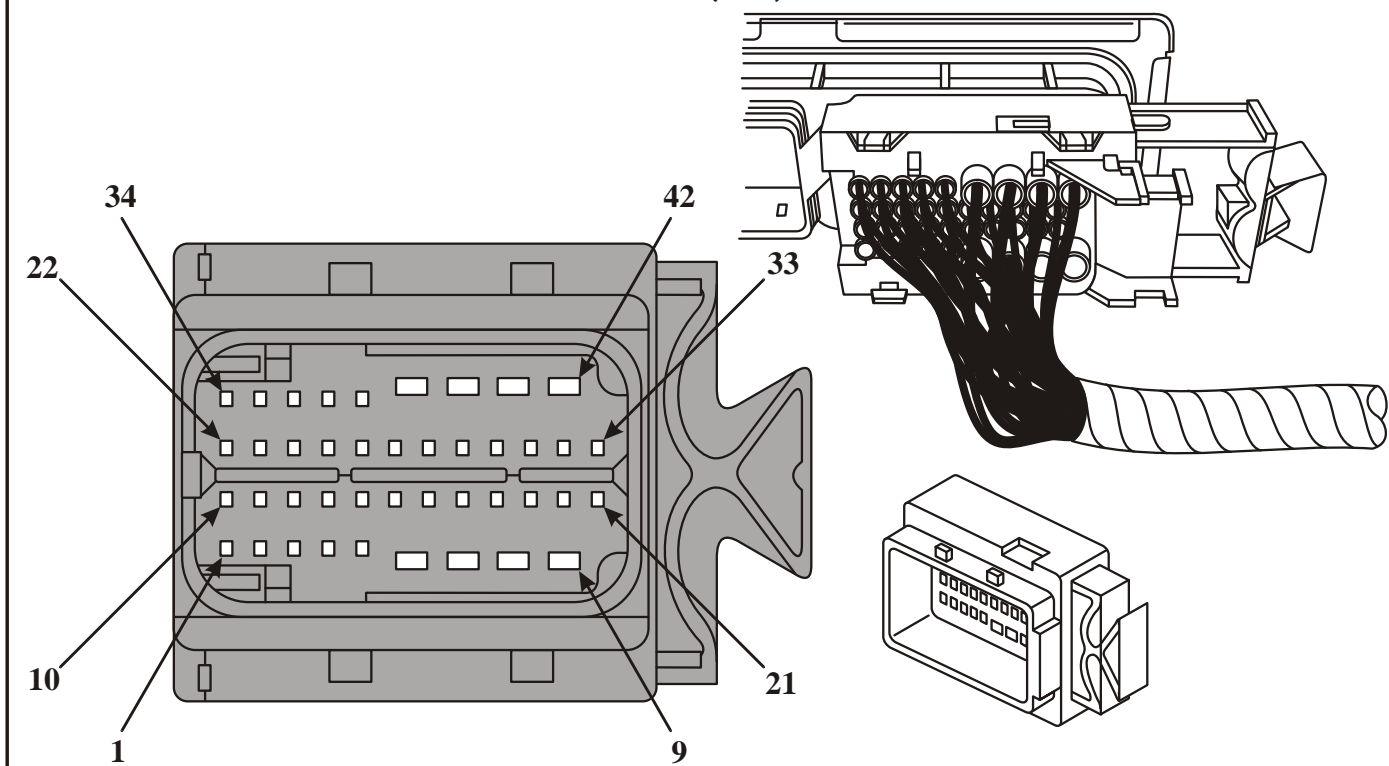

UNDERHOOD FUSE BLOCK LOCATIONS AND IDENTIFICATION

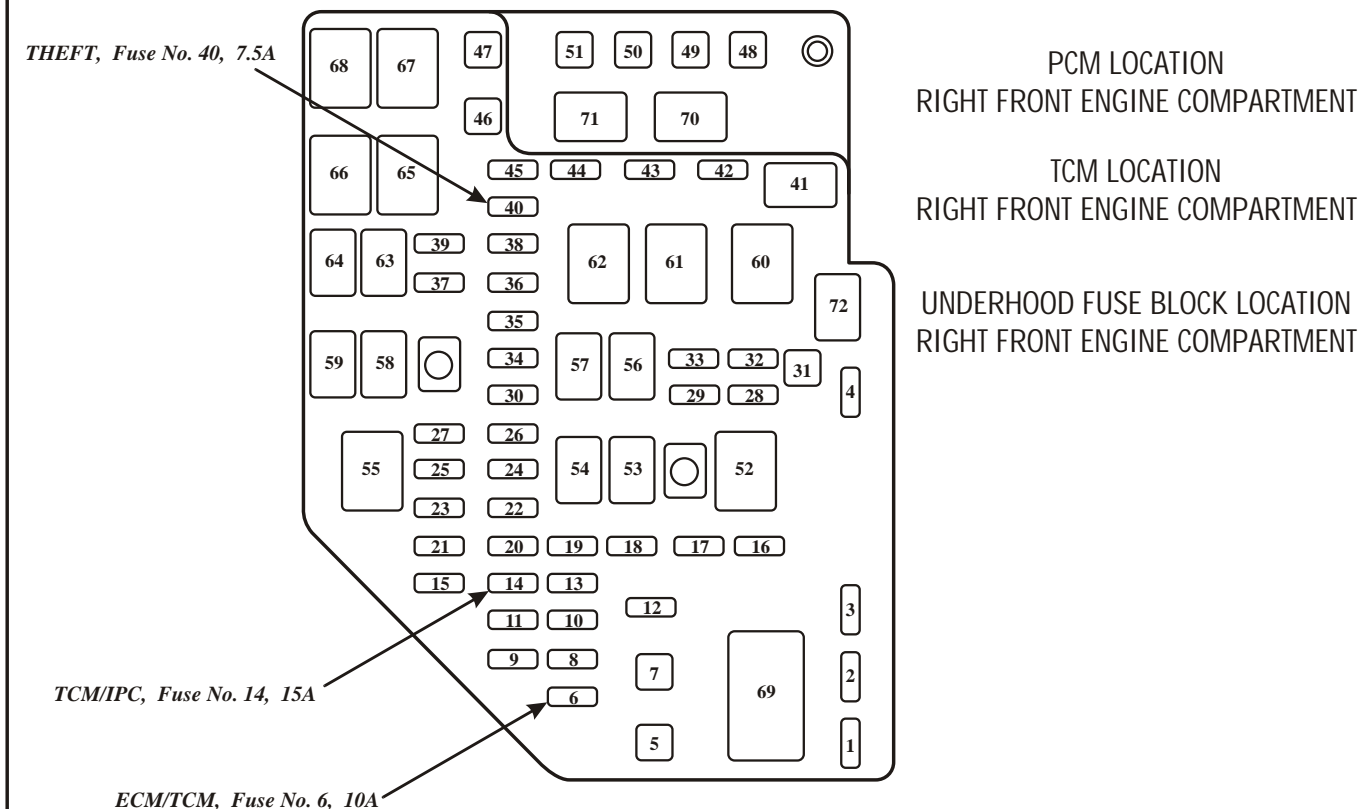

Copyright © 2002 ATSG

Figure 6



Technical Service Information

TRANSMISSION CONTROL MODULE (TCM) CONNECTOR IDENTIFICATION			
PIN NO.	WIRE COLOR	CIRCUIT NO.	FUNCTION
1	Yellow	400	Output Shaft Speed (OSS) Sensor High Signal
2	Purple	401	Output Shaft Speed (OSS) Sensor Low Signal
3	Orange/Black	1228	Pressure Control Solenoid High Control
4	Tan/Black	422	Torque Converter Clutch Solenoid Ground Control Signal
5	Yellow	343A	Accessory Voltage
6	Black/White	1551E	Ground
7	Black/White	1551C	Ground
8	Orange	1525	Solenoid Power Feed
9	Pink	239C	Ignition Switch Voltage
10	Orange/Black	1230	Transmission Input Shaft (ISS) High Signal
11	Dk. Blue/White	1231	Transmission Input Shaft (ISS) Low Signal
13	White/Black	5043B	Serial Data
15	Yellow/Black	1227	Transmission Fluid Temperature (TFT) High Signal
18	Yellow/Black	1223	2-3 Shift Solenoid "B" Ground Signal
19	Purple	898	4-5 Shift Solenoid "C" Ground Signal
21	Tan	2762	Transmission Fluid Temperature (TFT) Low Signal
24	Yellow	772	Transmission Range Switch Signal "B"
25	Gray	773	Transmission Range Switch Signal "C"
27	Red/White	1440D	Battery Positive Voltage
29	Lt. Blue/White	1229	Pressure Control Solenoid Low Control
30	Lt. Green	1222	1-2 Shift Solenoid "A" Ground Signal
32	White	2500	High Speed GMLAN Serial Data Bus + (CAN)
33	Green	2501	High Speed GMLAN Serial Data Bus - (CAN)
36	Tan/White	771	Transmission Range Switch Signal "A"
37	White	776	Transmission Range Switch Signal "P"
38	Purple	420E	TCC Brake Switch Signal
<p><i>Special Note: Pins 12, 14, 16, 17, 20, 22, 23, 26, 28, 31, 34, 35, 39, 40, 41, 42 are "Not Used".</i></p>			
Copyright © 2002 ATSG			

Figure 7



Technical Service Information

ELECTRICAL COMPONENTS

Electrical signals from various sensors provide information to the TCM or PCM, about vehicle speed, throttle position, engine coolant temp, range selector position, engine speed and converter turbine speed. The TCM or PCM uses this information to determine upshift and downshift speeds, apply or release of the TCC and what fluid pressure is needed to apply the clutch packs. This type of control provides consistent shift points and shift quality based on the operating conditions of the vehicle.

If for any reason the entire electronic control system of the transmission becomes disabled, all three shift solenoids will be turned off. This "Safety Mode" operating state forces the transmission to operate in 5th gear when the range selector is in any forward range. Also, the pressure control solenoid is turned off which will increase line pressure to the maximum.

Note: *Some models use an Engine Control Module (ECM) and a Transmission Control Module (TCM) and some models use a Powertrain Control Module (PCM) for both engine and transmission management.*

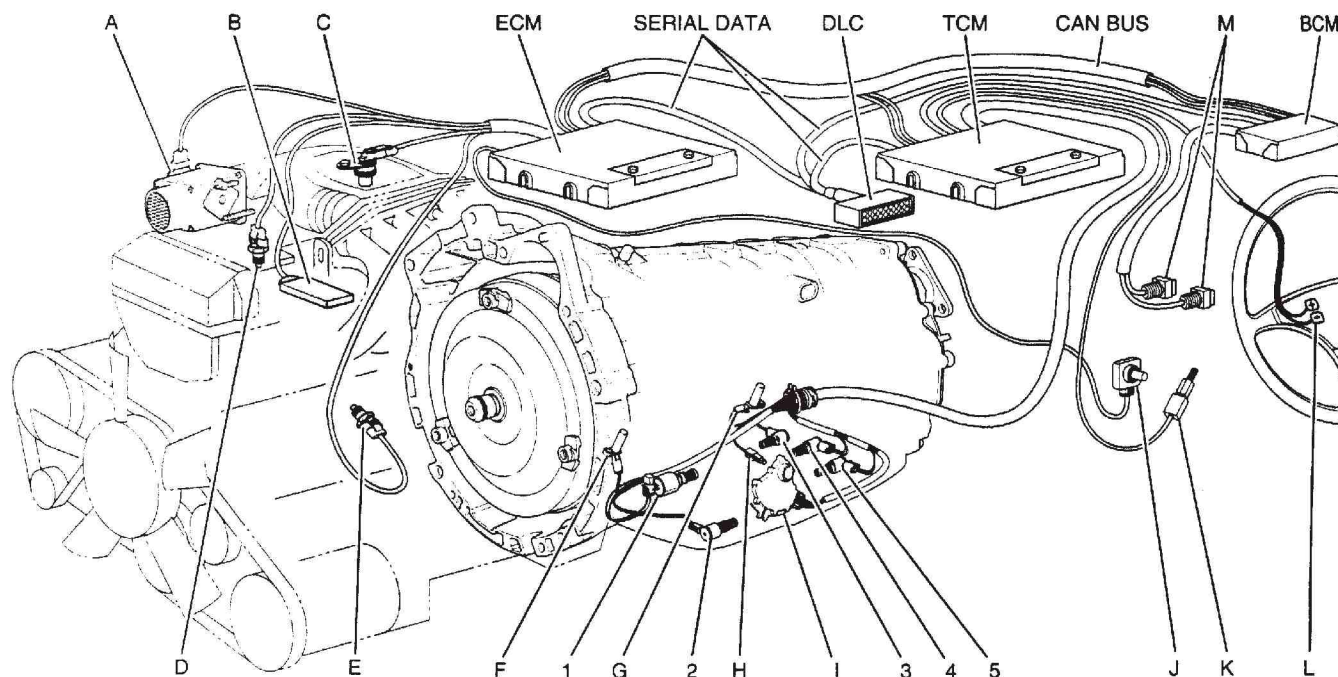

INFORMATION SENSORS

- A. THROTTLE POSITION SENSOR (TPS)
- B. MANIFOLD ABSOLUTE PRESSURE (MAP) SENSOR
- C. ENGINE SPEED SENSOR
- D. MANIFOLD AIR TEMPERATURE (MAT) SENSOR
- E. ENGINE COOLANT TEMPERATURE (ECT) SENSOR
- F. INPUT SPEED SENSOR (ISS)
- G. OUTPUT SPEED SENSOR (OSS)
- H. TRANSMISSION FLUID TEMPERATURE (TFT) SENSOR
- I. INTERNAL MODE SWITCH (IMS)
- J. ACCELERATOR PEDAL POSITION (APP) SENSOR
- K. TCC BRAKE SWITCH

ELECTRONIC CONTROLLERS

- * TRANSMISSION CONTROL MODULE (TCM) *SOME MODELS*
- * POWERTRAIN CONTROL MODULE (PCM)
- * ENGINE CONTROL MODULE (ECM) *SOME MODELS*
- * BODY CONTROL MODULE (BCM)
- * DIAGNOSTIC LINK CONNECTOR (DLC)

TRANSMISSION COMPONENTS

1. PRESSURE CONTROL SOLENOID
2. TCC/PWM SOLENOID
3. 1-2 SHIFT SOLENOID
4. 2-3 SHIFT SOLENOID
5. 4-5 SHIFT SOLENOID

Copyright © 2002 ATSG

Figure 8



Technical Service Information

INTERNAL MODE SWITCH

The Internal Mode Switch supplies the Transmission Control Module or Powertrain Control Module with input regarding the selector lever position (P, R, N, D, 4, 3, 2). The selector position is indicated by the state of five different On/Off switches, as shown below. The mode switch is located inside the transmission, on the manual shaft and is fixed in rotation to the main case by the dentent lever spring and no adjustment is ever necessary.

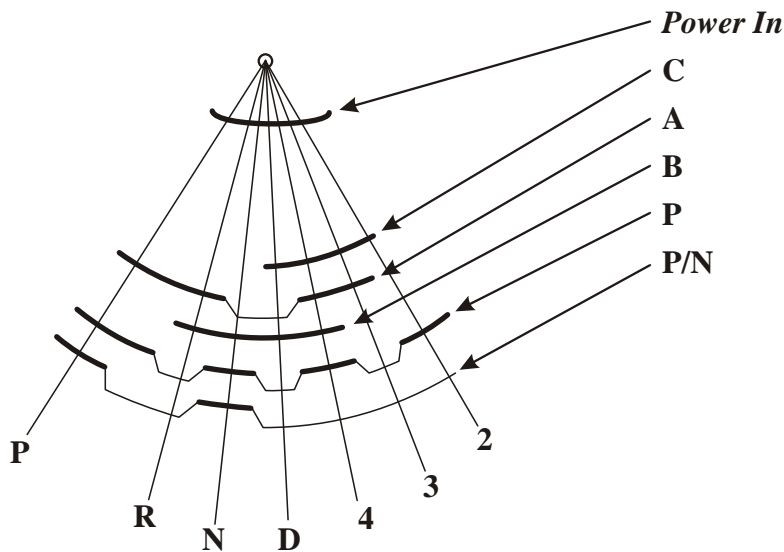

RANGE SELECTED	CIRCUIT				
	A	B	C	P	P/N
<i>Park</i>	1	0	0	1	1
<i>Reverse</i>	1	1	0	0	0
<i>Neutral</i>	0	1	0	1	1
<i>Overdrive</i>	0	1	0	0	0
<i>Manual 4</i>	1	1	1	1	0
<i>Manual 3</i>	1	0	1	0	0
<i>Manual 2</i>	0	0	1	1	0
1 = Switch Closed 0 = Switch Open					

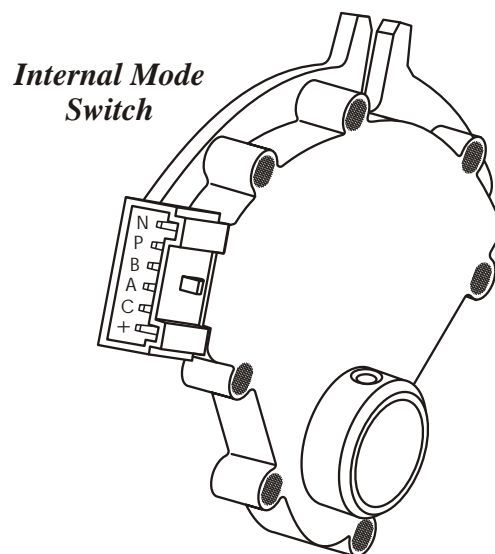

Copyright © 2002 ATSG

Figure 9



Technical Service Information

DIAGNOSTIC TROUBLE CODES (DTC) AND DESCRIPTION		
DTC	DESCRIPTION	BMW CODE
P0218	<i>Transmission Fluid Temp is 132°C (270°F) or greater for 10 minutes</i>	61
P0500	<i>Vehicle Speed is less than 5 km/h (3mph) for a total of 50 seconds</i>	
P0562	<i>System Voltage is less than 11 Volts for 10 seconds</i>	96
P0563	<i>System Voltage is greater than 18 Volts for 10 seconds</i>	96
P0601	<i>TCM EEPROM checksums do not match</i>	80
P0602	<i>TCM detects an unlocked calibration memory range</i>	
P0603	<i>TCM NVRAM checksums do not match</i>	81
P0604	<i>The data read from RAM does not match data written to RAM</i>	
P0711	<i>Erratic Transmission Fluid Temperature (TFT) signal</i>	34
P0712	<i>Transmission Fluid Temperature (TFT) shorted to ground, 315°F indicated</i>	34
P0713	<i>Transmission Fluid Temperature (TFT) open circuit, -40°F indicated</i>	34
P0716	<i>Input Shaft Speed (ISS) signal drops 1000 RPM or greater for 4 seconds</i>	33
P0717	<i>No Input Shaft Speed (ISS) signal</i>	33
P0719	<i>TCC Brake Switch stuck "ON" (Open)</i>	151
P0722	<i>No Output Shaft Speed (OSS) signal</i>	32
P0723	<i>Output Shaft Speed (OSS) signal drops 1300 RPM or greater for 3 seconds</i>	32
P0724	<i>TCC Brake Switch stuck "OFF" (Closed)</i>	151
P0727	<i>Invalid engine speed</i>	150
P0731	<i>Gear Ratio Error, 1st Gear</i>	50
P0732	<i>Gear Ratio Error, 2nd Gear</i>	52
P0733	<i>Gear Ratio Error, 3rd Gear</i>	53
P0734	<i>Gear Ratio Error, 4th Gear</i>	54
P0735	<i>Gear Ratio Error, 5th Gear</i>	55
P0741	<i>Torque Converter Clutch (TCC) slippage detected</i>	48
P0742	<i>Torque Converter Clutch (TCC) stuck "ON"</i>	
P0748	<i>Pressure Control Solenoid circuit, open or shorted to ground</i>	0
P0751	<i>1-2 Shift Solenoid "A" stuck "ON"</i>	
P0752	<i>1-2 Shift Solenoid "A" stuck "OFF"</i>	
P0756	<i>2-3 Shift Solenoid "B" stuck "OFF"</i>	
P0757	<i>2-3 Shift Solenoid "B" stuck "ON"</i>	
P0761	<i>4-5 Shift Solenoid "C" stuck "OFF"</i>	
P0762	<i>4-5 Shift Solenoid "C" stuck "ON"</i>	
P0850	<i>Park/Neutral switch circuit low (0 Volts) or high (12 Volts)</i>	60
P1621	<i>TCM detects checksum error between RAM and EEPROM test data</i>	80

Copyright © 2002 ATSG

Figure 10



Technical Service Information

GENERAL OPERATION AND DESCRIPTION

The 5L40-E transmission is a completely new design rear wheel drive unit and was designed to be a four or five speed transmission. The same case and components are used for both applications with the exclusion of the 2nd clutch, 2nd coast clutch and the 2nd sprag clutch, and the use of a smaller ravigneaux planetary carrier assembly in the 4 speed version.

The Hydra-matic 5L40-E is a fully automatic, five forward speed, rear wheel drive, fully electronic controlled transmission, with a maximum torque rating of 360 Nm. It consists primarily of a four element (Lock-Up) torque converter, one ravigneaux planetary gear set, nine multiple-disc friction clutch packs, four mechanical sprag clutches and a hydraulic pressurization and control system. We have provided you with an illustration to identify the location of the nine different clutch packs, the four mechanical sprag clutches and a component application chart in Figures 2 and 3.

The ravigneaux planetary gear set provides the five forward speeds and reverse. Changing gear ratios is fully automatic and is accomplished through the use of a Transmission Control Module (TCM). The TCM receives and monitors various electronic sensor inputs and uses this information to shift the transmission at the optimum time, as illustrated in Figure 8.

The TCM commands three on/off Shift Solenoids to control shift timing. The TCM controls shift feel through the Pressure Control Solenoid. The TCM also controls the apply and release of the torque converter clutch through a TCC/PWM Solenoid. Refer to Figure 4 for the solenoid application chart for each gear, along with case connector pin identification and a resistance chart for the internal components. Refer to Figure 5 for the internal wiring schematic. Notice also in Figure 5 that this transmission uses an Internal Mode Switch (IMS). The IMS operation is illustrated and explained in Figure 9, and description of each gear range is explained in this section.

The hydraulic system primarily consists of a 13 vane pump, two control valve bodies, two channel plates, converter housing and transmission case. The pump maintains the working pressures needed to stroke the clutch pistons that apply or release the friction components.

STANDARD SHIFT QUADRANT

With the "Standard" range indicator, as illustrated in Figure 12, the transmission may be operated in any one of the seven different positions shown on the shift quadrant as follows;

P - Park position enables the engine to be started while preventing the vehicle from rolling either forward or backward. Park position should not be selected until the vehicle has come to a complete stop. For safety reasons, the vehicles parking brake should always be used in addition to the "Park" position.

R - Reverse position enables the vehicle to be operated in a rearward direction.

N - Neutral position enables the engine to start and operate without driving the vehicle. If necessary, this position should be selected to restart the engine while the vehicle is moving.

D - Overdrive range should be used for all normal driving conditions for maximum efficiency and fuel economy. Overdrive range allows the transmission to upshift automatically into each of the 5 forward gear ratios. Downshifts to a lower gear are possible for safe passing by depressing the accelerator, or by manually selecting a lower gear with the shift selector.

4 - Manual Fourth can be used for conditions where it may be desirable to use only 4 gear ratios, such as trailer towing or hilly terrain. This range is also helpful for engine braking when descending slight grades. Upshifts and downshifts all occur automatically, except 5th gear is prohibited. Manual Fourth can be selected at any vehicle speed but will downshift into 4th gear only if vehicle speed is low enough not to over-rev the engine. Manual downshifts are controlled by the TCM, not the manual valve location.

3 - Manual Third can be used for conditions where it is desirable to use only 3 gear ratios, such as trailer towing or hilly terrain. This range also helps for engine braking when descending grades. Upshifts and downshifts all occur automatically, except 4th and 5th is prohibited. Manual 3rd can be selected at any vehicle speed but will downshift to 3rd only if vehicle speed is low enough not to over-rev the engine. Manual downshifts are controlled by the TCM, not the manual valve.



Technical Service Information

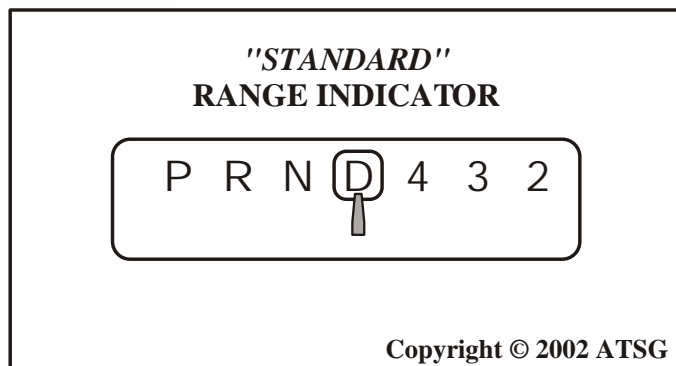

Figure 12

FLUID LEVEL CHECKING PROCEDURE

Start the engine as it **must** be running to properly check the fluid level. Depress the brake pedal and move the shift lever through all of the gear ranges, pausing a few seconds in each range. Return the shift lever to the PARK range.

Raise the vehicle on a hoist. The vehicle **must** be level with the **engine running** and the shift lever in the PARK range.

Caution:

The engine must be running when Check/Fill plug is removed, or excessive fluid loss will occur. Transmission fluid may be hot, and since the actual fluid level is unknown, stand clear and take precautions with protective clothing when removing the plug. Have a container ready to capture any lost fluid. Do not turn the engine off with the fill plug removed as you can be injured by hot transmission fluid being expelled from the Check/Fill plug opening.

Let the transmission fluid temperature rise until it has reached a temperature of 90-125°F (30-50°C). Remove the transmission fill plug with care as described above. Use Figure 13 for the locations as they differ from gasoline models to diesel models. The fluid should trickle from the plugs opening.

Add Dexron® III automatic transmission fluid in increments of 0.5 L (0.5 quart) until the fluid drains from the threaded opening. Torque specification for the Check/Fill plug is 15 ft.lb.

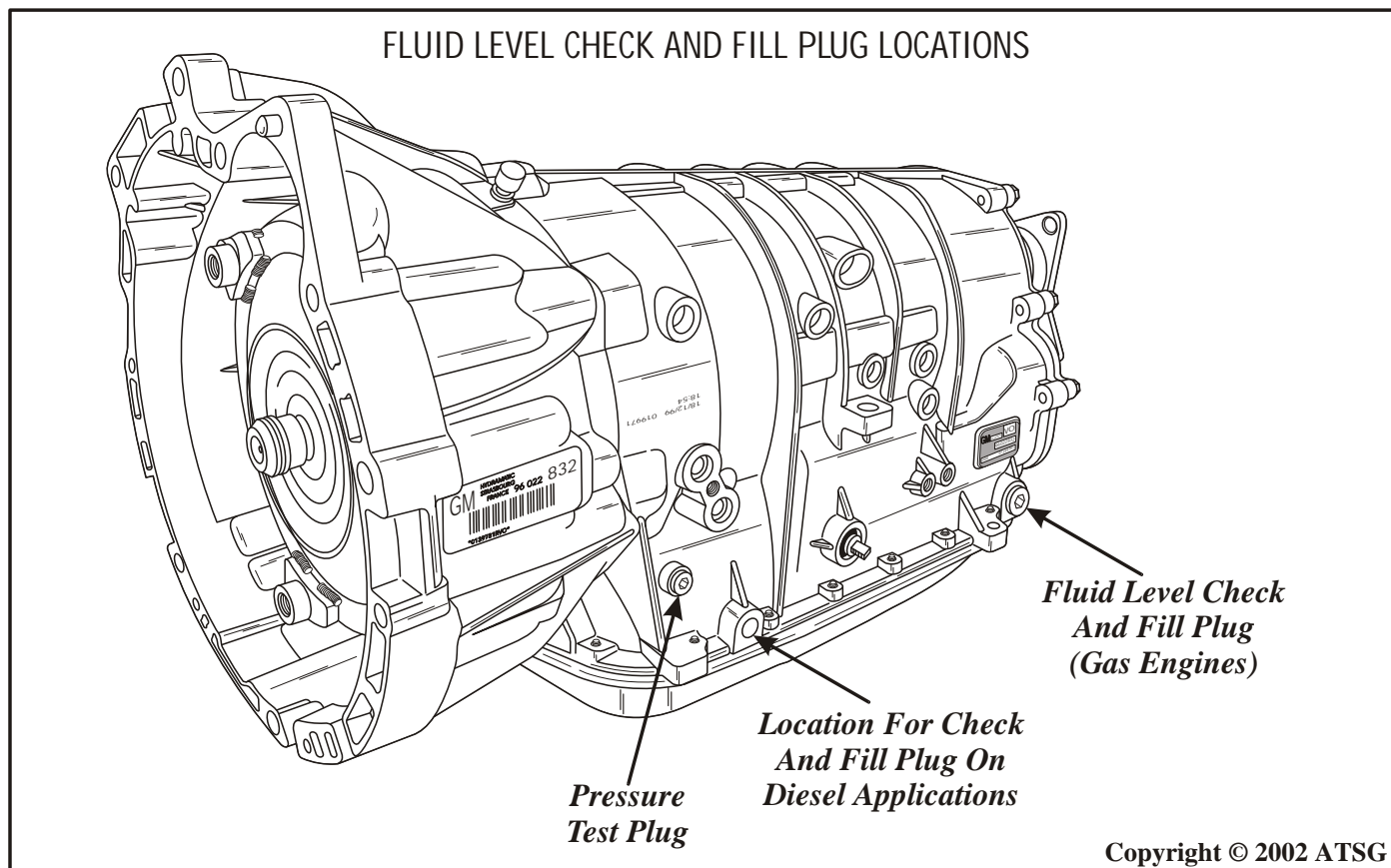
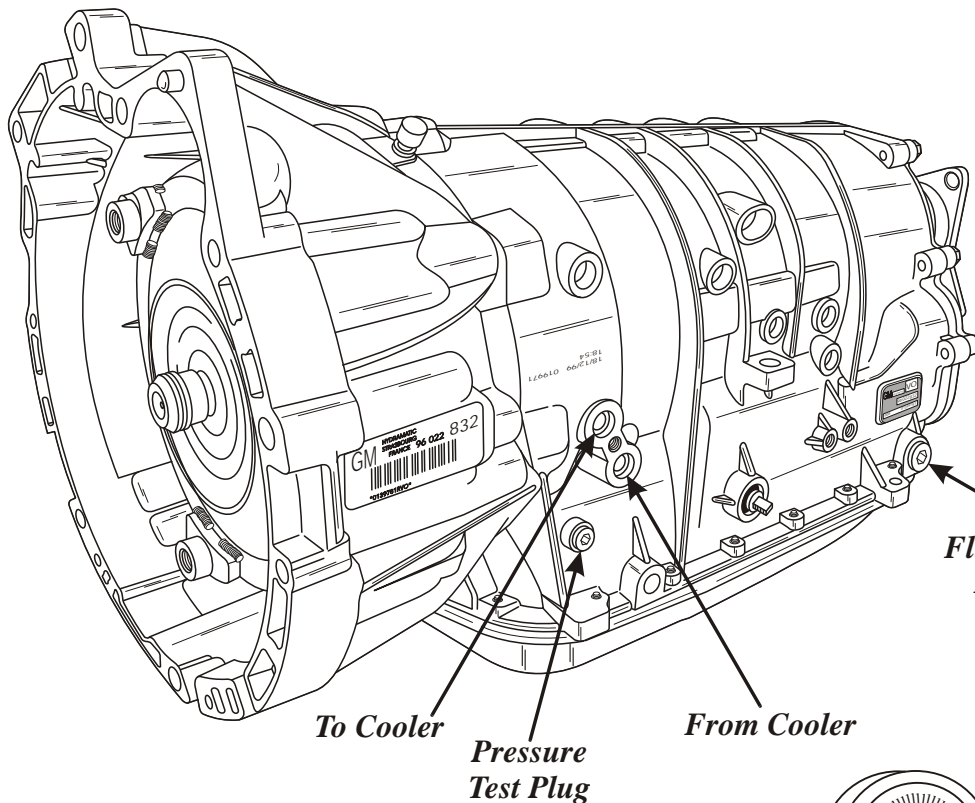

Figure 13



Technical Service Information

LINE PRESSURE TEST



Fluid Level Check And Fill Plug

To Cooler

Pressure Test Plug

From Cooler

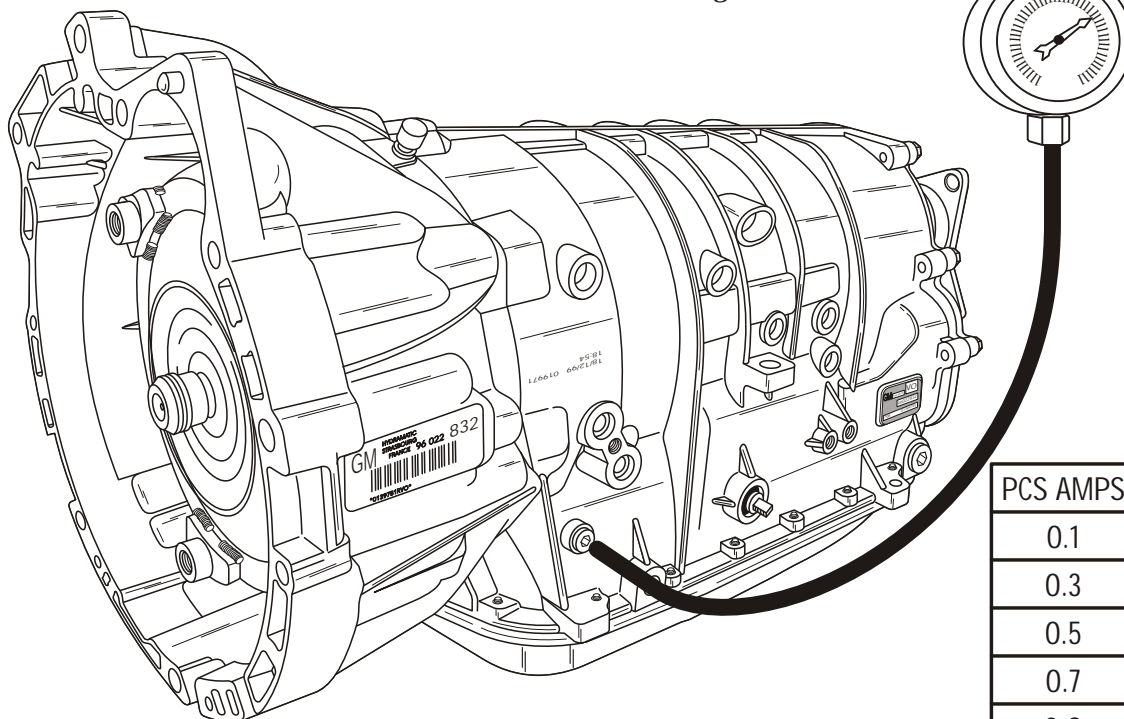

RANGE	LINE PRESSURE	
	Minimum	Maximum
<i>P, N, D, M4, M3, M2</i>	<i>48 psi</i>	<i>180 psi</i>
<i>REVERSE</i>	<i>60 psi</i>	<i>232 psi</i>

PCS AMPS	PRESSURE
0.1	173-197 PSI
0.3	162-188 PSI
0.5	145-169 PSI
0.7	117-140 PSI
0.8	95-119 PSI
0.9	63-89 PSI
1.1	42-64 PSI
ENGINE AT 1300 RPM	

Copyright © 2002 ATSG

Figure 14



Technical Service Information

BELL HOUSING OIL PASSAGES

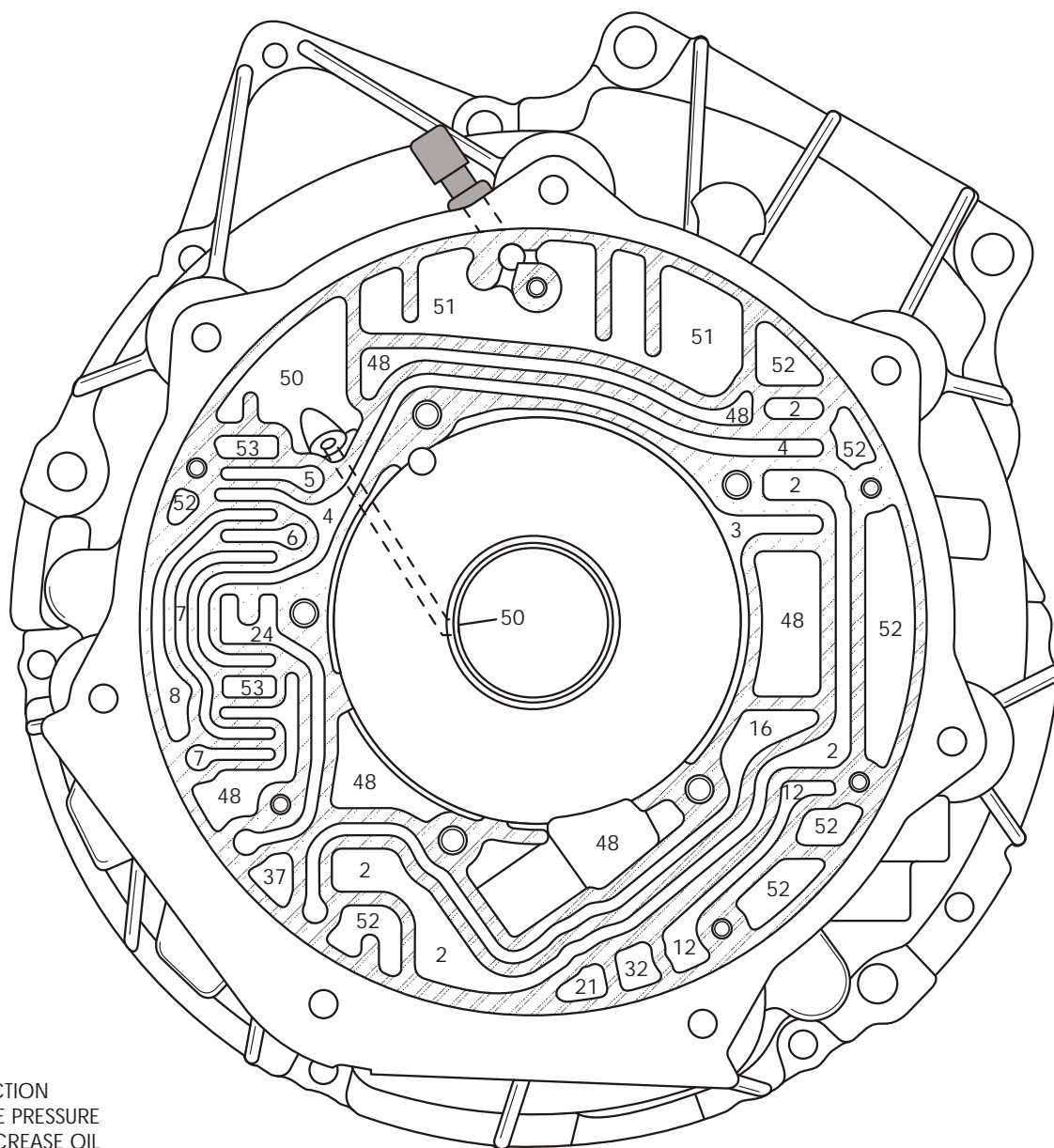

1. SUCTION
2. LINE PRESSURE
3. DECREASE OIL
4. CONVERTER FEED
5. CONVERTER RELEASE
6. CONVERTER APPLY
7. REGULATED APPLY
8. TO COOLER
9. LUBE FROM COOLER
12. THROTTLE SIGNAL
16. REVERSE CLUTCH
21. FORWARD CLUTCH
24. TCC SIGNAL
32. COAST CLUTCH
37. DIRECT CLUTCH
48. EXHAUST
50. CONVERTER SEAL DRAIN
51. VENT
52. VOID
53. CONVERTER FEED LIMIT

Copyright © 2002 ATSG

Figure 15



Technical Service Information

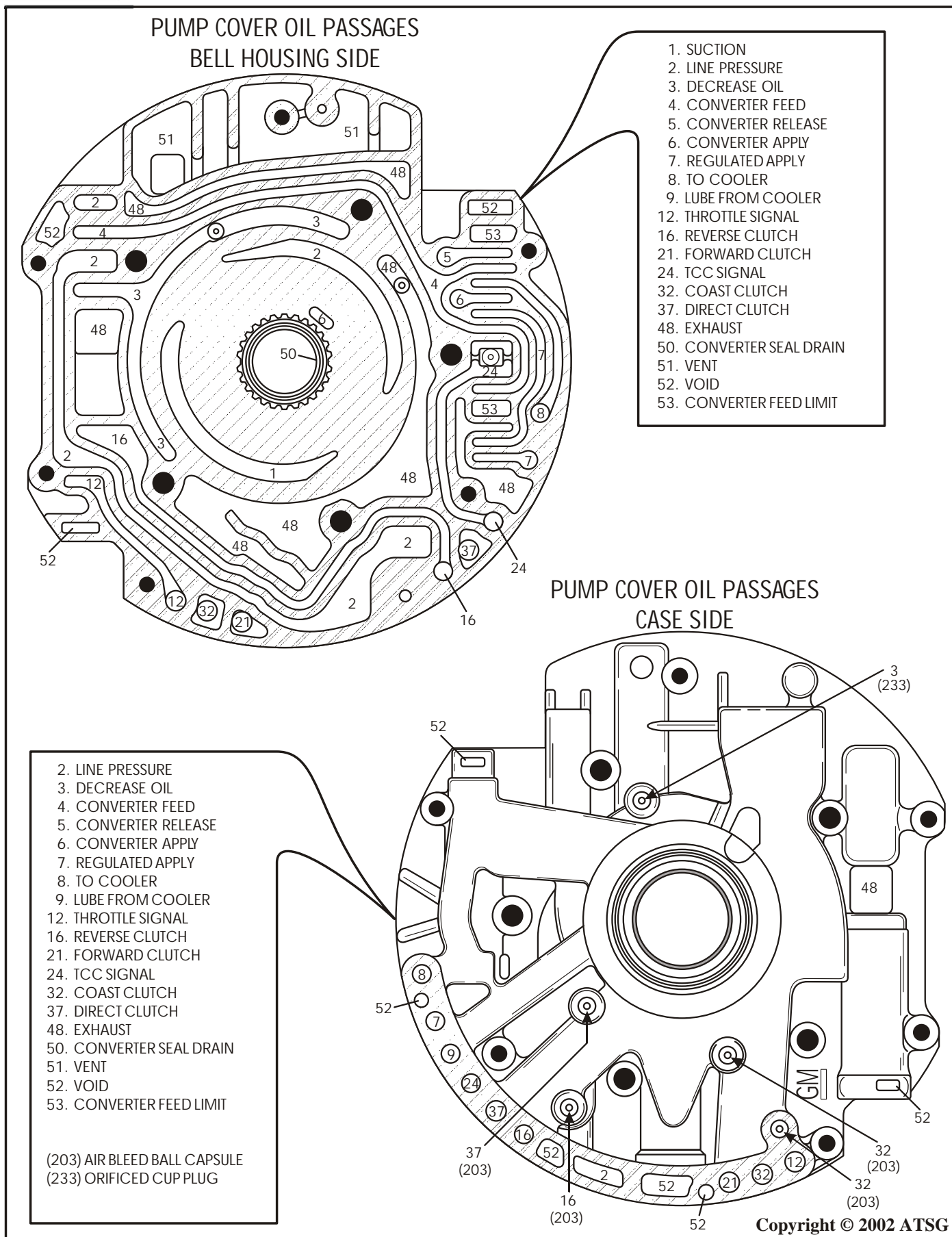
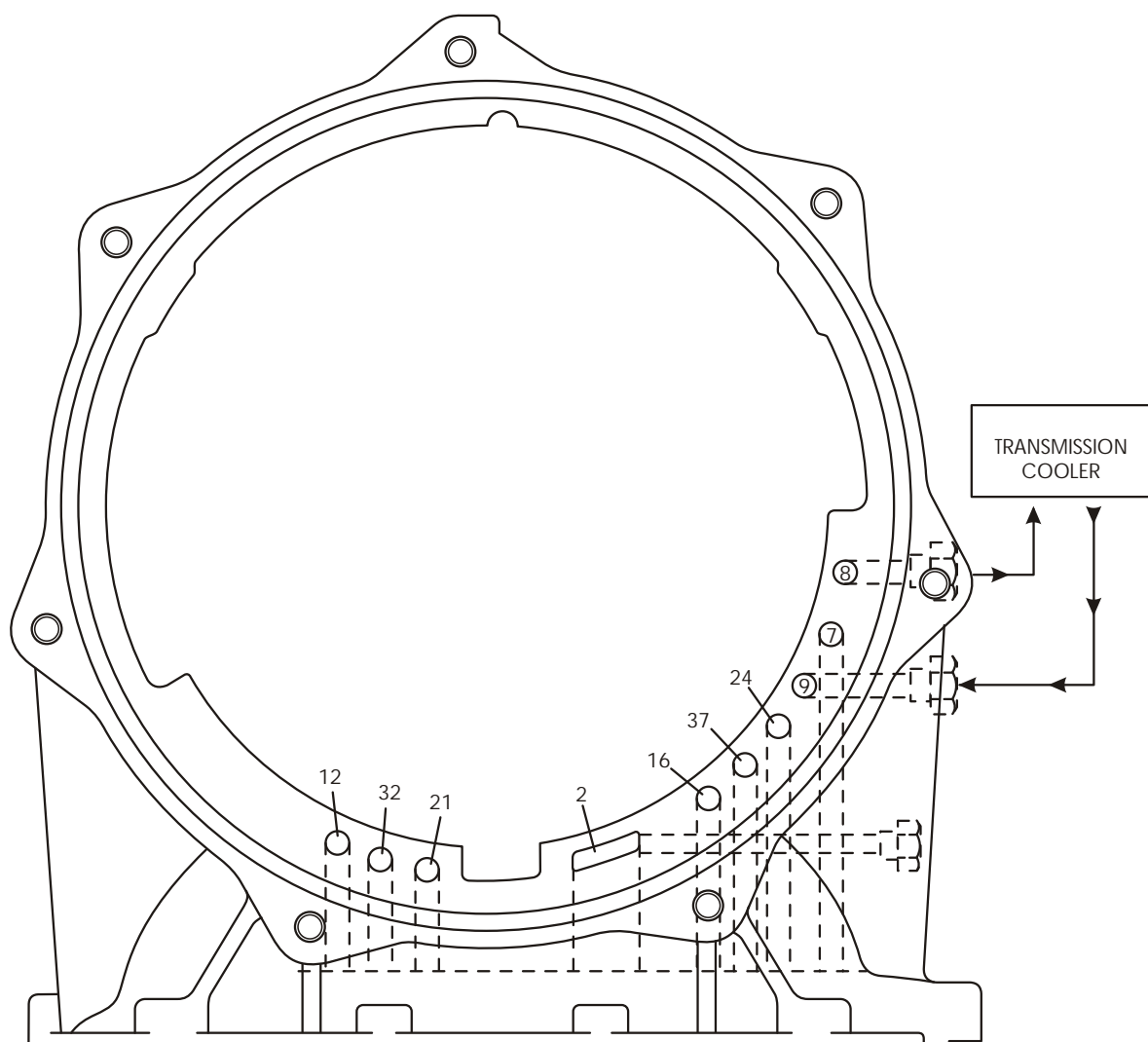

Figure 16



Technical Service Information

MAIN CASE "FRONT" OIL PASSAGES



- 2. LINE PRESSURE
- 7. REGULATED APPLY
- 8. TO COOLER
- 9. LUBE FROM COOLER
- 12. THROTTLE SIGNAL
- 16. REVERSE CLUTCH
- 21. FORWARD CLUTCH
- 24. TCC SIGNAL
- 32. COAST CLUTCH
- 37. DIRECT CLUTCH

Copyright © 2002 ATSG

Figure 17



Technical Service Information

MAIN CASE "BOTTOM" OIL PASSAGES

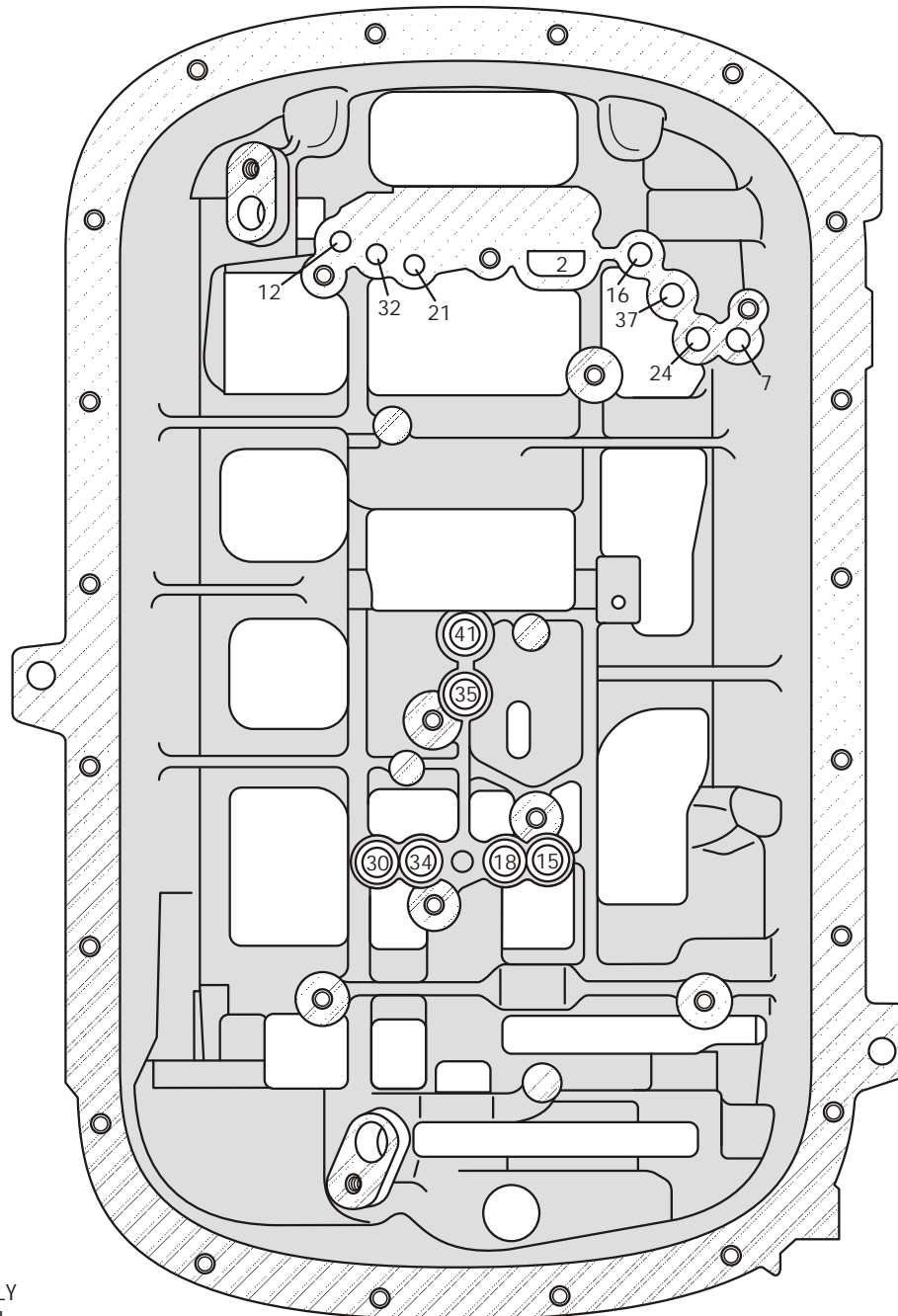

- 2. LINE PRESSURE
- 7. REGULATED APPLY
- 12. THROTTLE SIGNAL
- 15. REVERSE LOCK OUT
- 16. REVERSE CLUTCH
- 18. LOW/REV CLUTCH OR RLO
- 21. FORWARD CLUTCH
- 24. TCC SIGNAL
- 30. SECOND CLUTCH
- 32. COAST CLUTCH
- 34. 2ND COAST CLUTCH
- 35. INTERMEDIATE CLUTCH
- 37. DIRECT CLUTCH
- 41. OVERDRIVE CLUTCH

Copyright © 2002 ATSG

Figure 18



Technical Service Information

"FRONT" VALVE BODY OIL PASSAGES

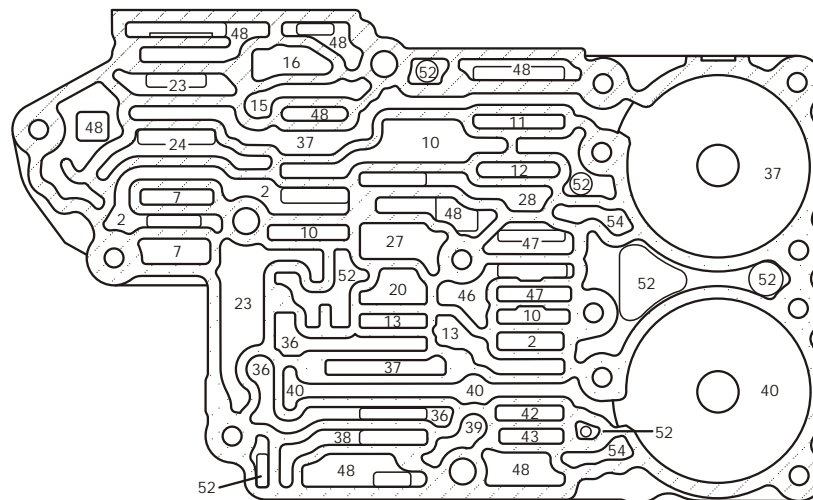

"REAR" VALVE BODY OIL PASSAGES

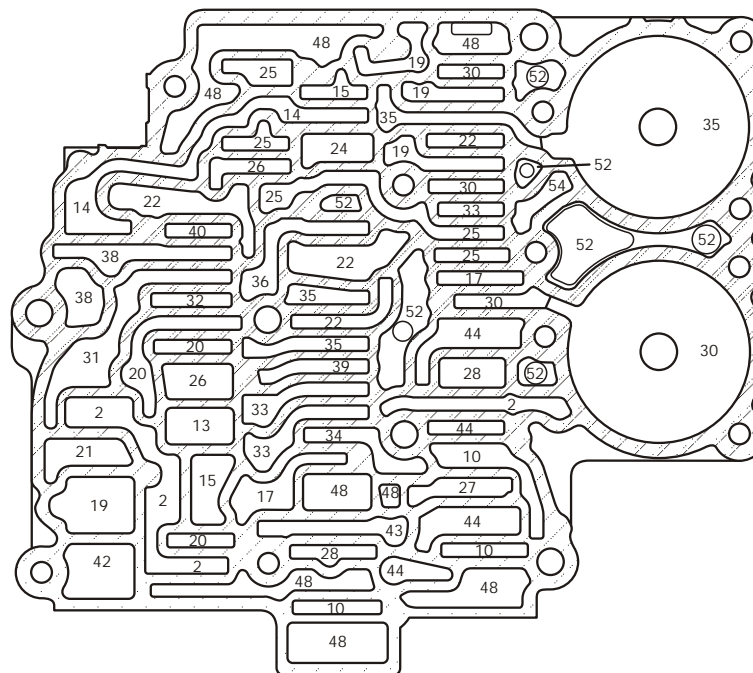

- | | | |
|----------------------------|-------------------------|-----------------------------|
| 2. LINE PRESSURE | 19. D432 | 36. 345 |
| 3. DECREASE OIL | 20. 123 | 37. DIRECT CLUTCH |
| 4. CONVERTER FEED | 21. FORWARD CLUTCH | 38. 45 |
| 5. CONVERTER RELEASE | 22. 2345 | 39. OVERDRIVE CLUTCH FEED 1 |
| 6. CONVERTER APPLY | 23. 2345 OR REVERSE | 40. OVERDRIVE CLUTCH FEED 2 |
| 7. REGULATED APPLY | 24. TCC SIGNAL | 41. OVERDRIVE CLUTCH |
| 8. TO COOLER | 25. 123 REGULATED | 42. 32 |
| 9. LUBE FROM COOLER | 26. 123 BRAKING | 43. 32 SAFETY MODE |
| 10. FEED LIMIT | 27. 1-2 SIGNAL | 44. FDL |
| 11. FILTERED FEED LIMIT | 28. 2-3 SIGNAL | 45. 32 SAFETY MODE/FDL |
| 12. THROTTLE SIGNAL | 29. 4-5 SIGNAL | 46. MEMORY PILOT |
| 13. LINE SAFETY MODE | 30. SECOND CLUTCH | 47. MEMORY |
| 14. REVERSE | 31. COAST FEED CLUTCH | 48. EXHAUST |
| 15. REVERSE LOCK OUT (RLO) | 32. COAST CLUTCH | 51. VENT |
| 16. REVERSE CLUTCH | 33. 23 REGULATED | 52. VOID |
| 17. LOW AND REVERSE CLUTCH | 34. SECOND COAST CLUTCH | 53. CONVERTER FDL |
| 18. LOW/REV CLUTCH OR RLO | 35. INTERMEDIATE CLUTCH | 54. ACCUMULATOR |

Copyright © 2002 ATSG

Figure 19



Technical Service Information

"TYPICAL" SPACER PLATE

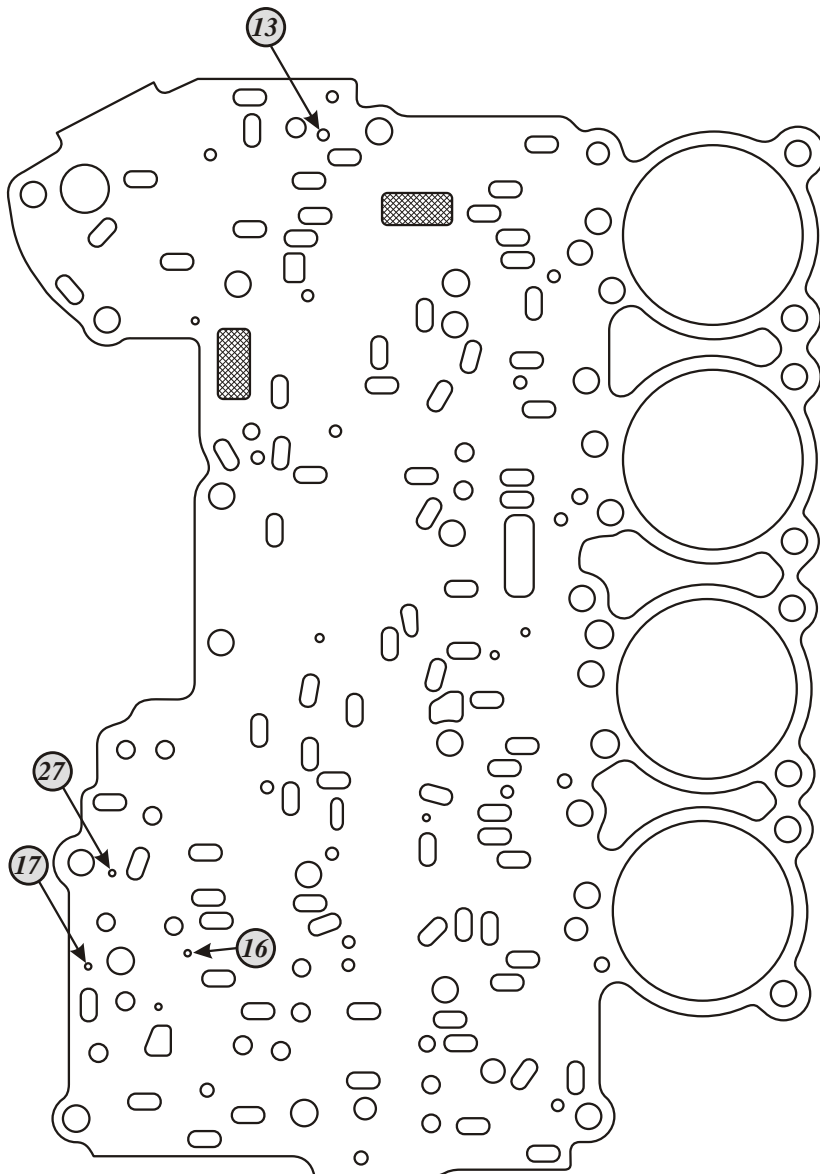

Copyright © 2002 ATSG

Figure 20



Technical Service Information

"TOP" CHANNEL PLATE OIL PASSAGES

"CASE" SIDE

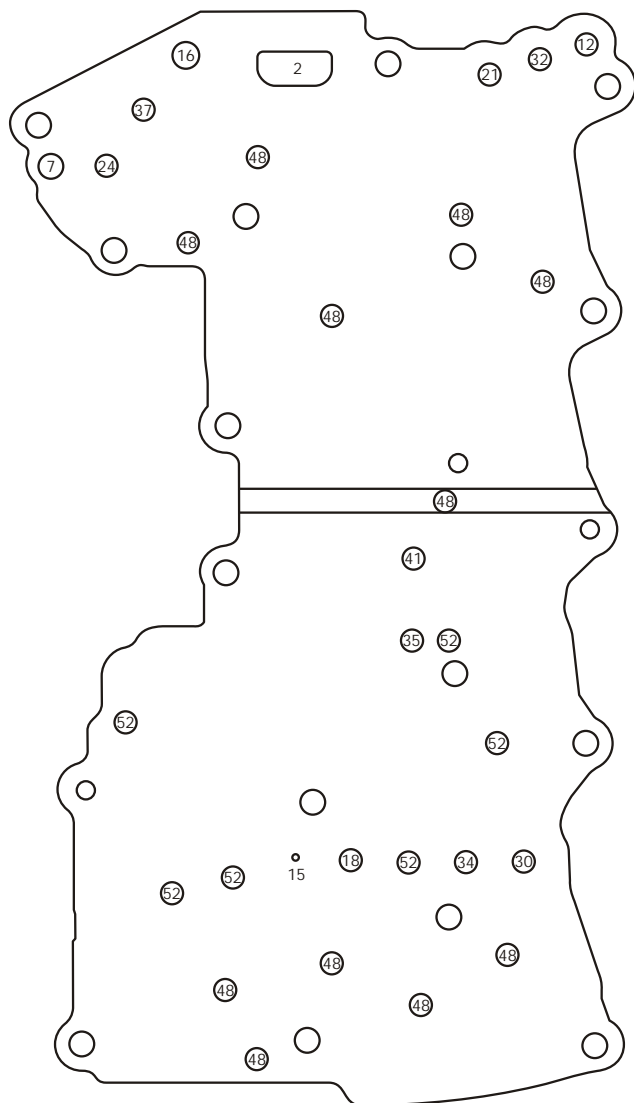

"BOTTOM" CHANNEL PLATE SIDE

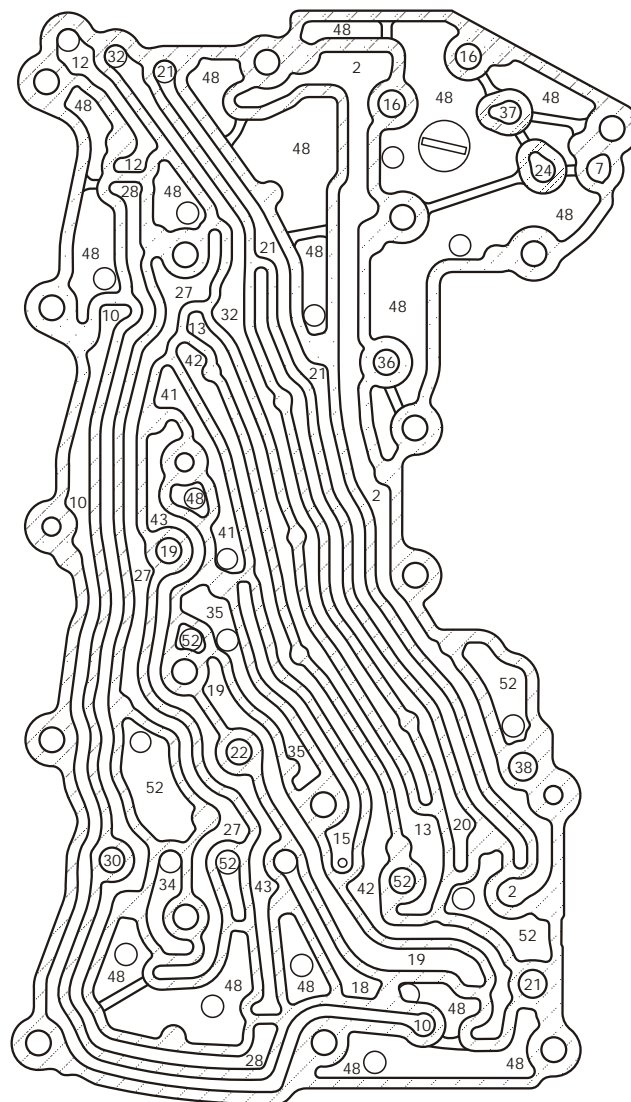

- | | | |
|----------------------------|-------------------------|-----------------------------|
| 2. LINE PRESSURE | 19. D432 | 36. 345 |
| 3. DECREASE OIL | 20. 123 | 37. DIRECT CLUTCH |
| 4. CONVERTER FEED | 21. FORWARD CLUTCH | 38. 45 |
| 5. CONVERTER RELEASE | 22. 2345 | 39. OVERDRIVE CLUTCH FEED 1 |
| 6. CONVERTER APPLY | 23. 2345 OR REVERSE | 40. OVERDRIVE CLUTCH FEED 2 |
| 7. REGULATED APPLY | 24. TCC SIGNAL | 41. OVERDRIVE CLUTCH |
| 8. TO COOLER | 25. 123 REGULATED | 42. 32 |
| 9. LUBE FROM COOLER | 26. 123 BRAKING | 43. 32 SAFETY MODE |
| 10. FEED LIMIT | 27. 1-2 SIGNAL | 44. FDL |
| 11. FILTERED FEED LIMIT | 28. 2-3 SIGNAL | 45. 32 SAFETY MODE/FDL |
| 12. THROTTLE SIGNAL | 29. 4-5 SIGNAL | 46. MEMORY PILOT |
| 13. LINE SAFETY MODE | 30. SECOND CLUTCH | 47. MEMORY |
| 14. REVERSE | 31. COAST FEED CLUTCH | 48. EXHAUST |
| 15. REVERSE LOCK OUT (RLO) | 32. COAST CLUTCH | 51. VENT |
| 16. REVERSE CLUTCH | 33. 23 REGULATED | 52. VOID |
| 17. LOW AND REVERSE CLUTCH | 34. SECOND COAST CLUTCH | 53. CONVERTER FDL |
| 18. LOW/REV CLUTCH OR RLO | 35. INTERMEDIATE CLUTCH | 54. ACCUMULATOR |

Copyright © 2002 ATSG

Figure 21



Technical Service Information

Check Ball No. 1: Seats to force reverse lockout fluid through orifice 13 in the spacer plate, and into the reverse clutch circuit to help control the apply rate of the reverse clutch.

Check Ball No. 2: Seats to allow either reverse fluid (In Reverse) or 2345 fluid (In 2nd, 3rd, 4th, and 5th) to enter the reverse or 2345 circuit, while blocking the other fluid circuit.

Check Ball No. 3: Seats to force four five fluid through orifice 27 in the spacer plate and into the overdrive clutch feed circuit to help control the apply rate of the overdrive clutch.

Check Ball No. 4: Seats to force 123 fluid through orifice 16 in the spacer plate and into the coast clutch feed circuit to help control the apply rate of the coast clutch.

Check Ball No. 5: Seats to force forward clutch fluid through orifice 17 in the spacer plate to help control the apply rate of the coast clutch.

Check Ball No. 6: Seats to force forward clutch fluid through orifice 15 in the spacer plate and into the forward clutch circuit to help control the apply rate of the forward clutch.

Check Ball No. 7: Seated by a calibrated spring that goes in channel plate before the check ball and provides extra D432 fluid in the forward and coast clutch circuits to reduce garage shift response time.

Check Ball No. 8: Seats to allow either low/reverse clutch fluid (In 1st gear coast condition) or reverse lockout (RLO) fluid (In Reverse) to enter the low/reverse clutch or reverse lockout circuit, while blocking the other fluid circuit.

Check Ball No. 9: Seats to force two-three regulated fluid through orifice 22 in the spacer plate and into the overdrive clutch feed 1 circuit to help control the apply rate of the overdrive clutch when in a 3rd gear coast condition.

Check Ball No. 10: Seats to allow either three-two safety mode fluid (Safety Mode Operation Only) or FDL fluid (In 1st Gear) to enter the 3-2 safety mode or FDL fluid circuit while blocking the other.

Check Ball No. 11: Seats to force two-three regulated fluid through orifice 23 in the spacer plate and into the second coast clutch circuit to help control the apply rate of the 2nd coast clutch when in a 2nd gear coast condition. **Note: This Check Ball not used in 4L40-E models.**

Check Ball No. 12: Seats to allow either overdrive clutch feed 1 fluid (In a 3rd Gear Coast condition) or overdrive clutch feed 2 fluid (In 5th Gear) to enter the overdrive clutch circuit while blocking the other fluid circuit.

Copyright © 2002 ATSG

Figure 22



Technical Service Information

CHECK BALL LOCATIONS AND DESCRIPTION

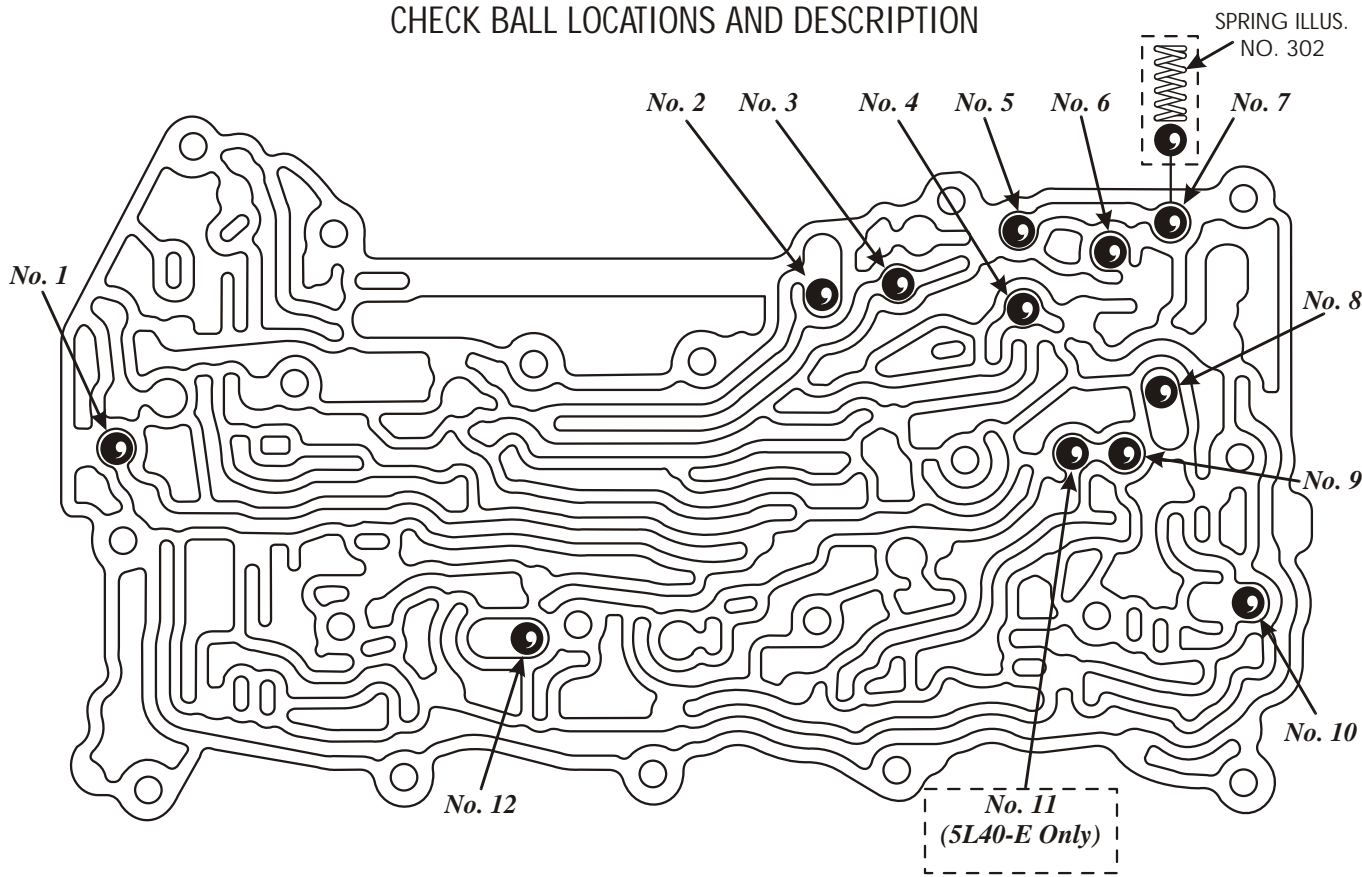

"TYPICAL" 5L40-E SPACER PLATE

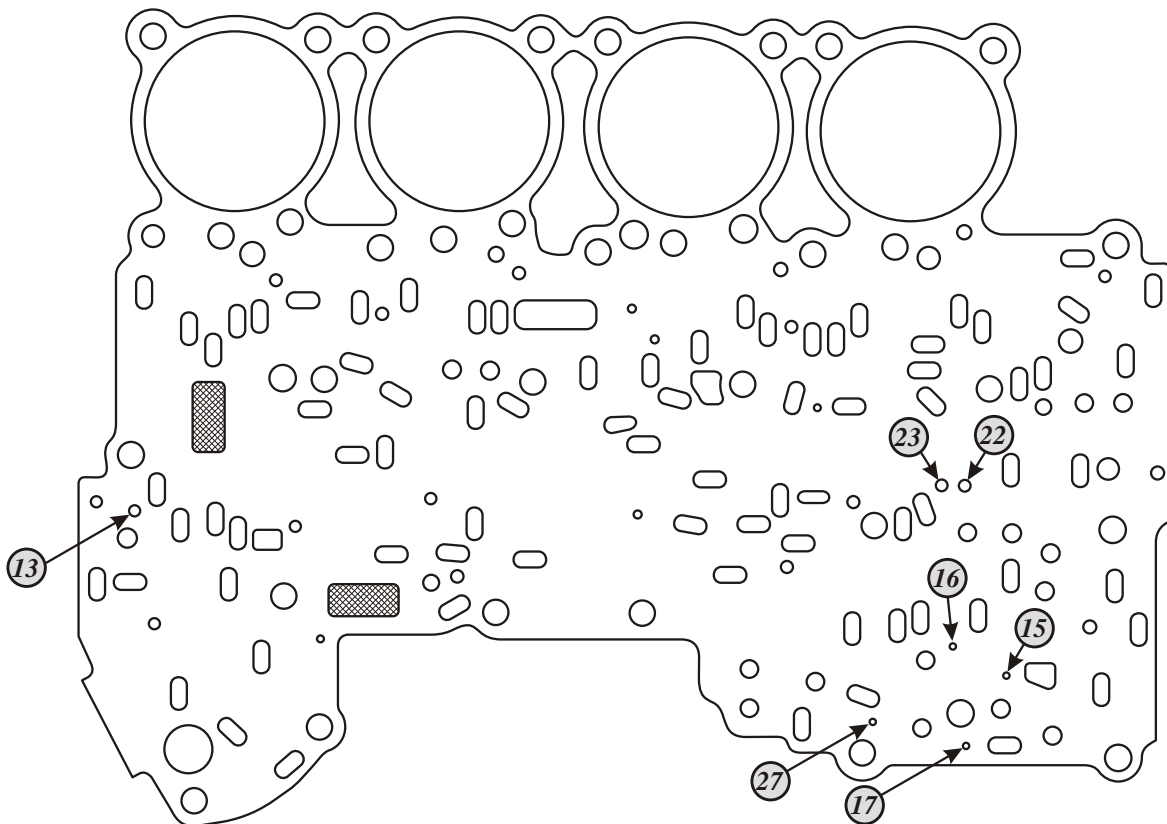

Copyright © 2002 ATSG

Figure 23



Technical Service Information

"BOTTOM" CHANNEL PLATE OIL PASSAGES

"TOP" CHANNEL PLATE SIDE

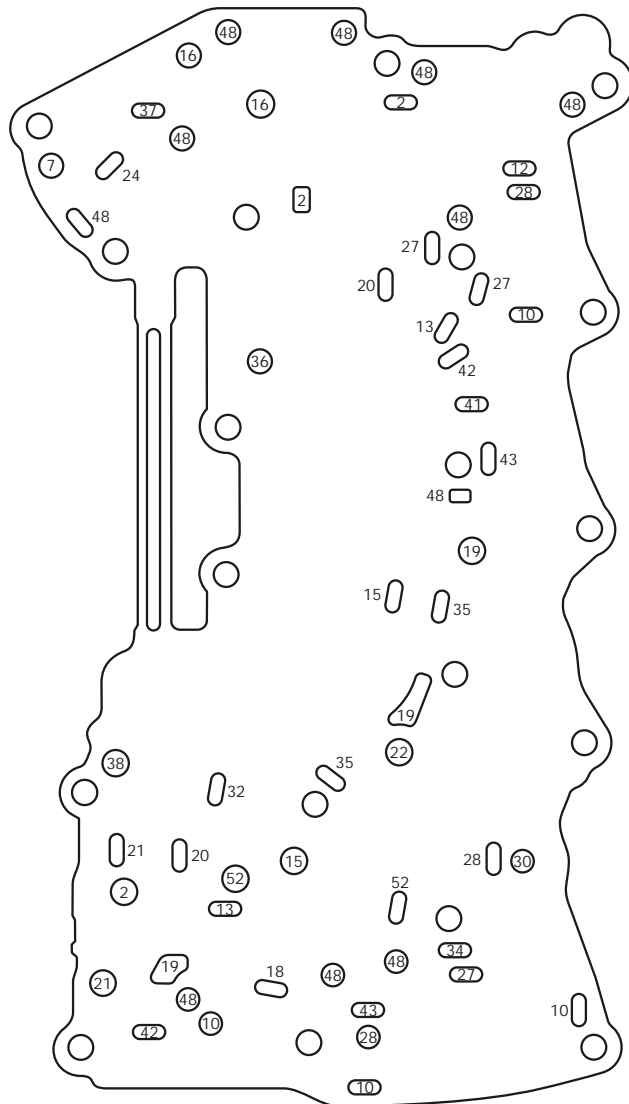

"VALVE BODY" SIDE

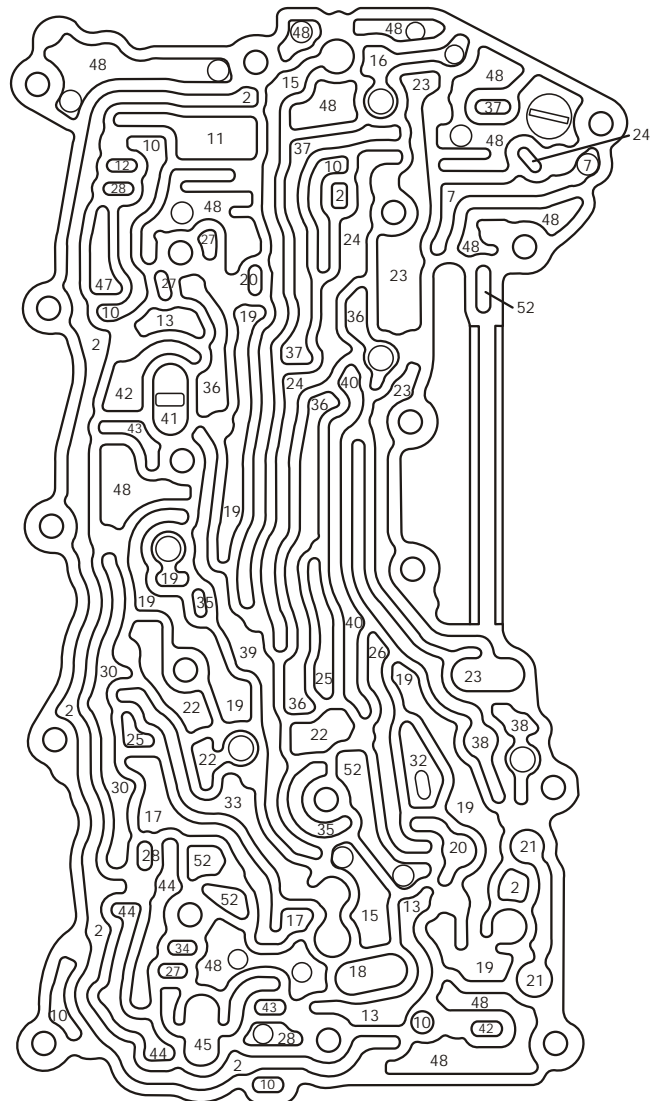

- | | | |
|----------------------------|-------------------------|-----------------------------|
| 2. LINE PRESSURE | 19. D432 | 36. 345 |
| 3. DECREASE OIL | 20. 123 | 37. DIRECT CLUTCH |
| 4. CONVERTER FEED | 21. FORWARD CLUTCH | 38. 45 |
| 5. CONVERTER RELEASE | 22. 2345 | 39. OVERDRIVE CLUTCH FEED 1 |
| 6. CONVERTER APPLY | 23. 2345 OR REVERSE | 40. OVERDRIVE CLUTCH FEED 2 |
| 7. REGULATED APPLY | 24. TCC SIGNAL | 41. OVERDRIVE CLUTCH |
| 8. TO COOLER | 25. 123 REGULATED | 42. 32 |
| 9. LUBE FROM COOLER | 26. 123 BRAKING | 43. 32 SAFETY MODE |
| 10. FEED LIMIT | 27. 1-2 SIGNAL | 44. FDL |
| 11. FILTERED FEED LIMIT | 28. 2-3 SIGNAL | 45. 32 SAFETY MODE/FDL |
| 12. THROTTLE SIGNAL | 29. 4-5 SIGNAL | 46. MEMORY PILOT |
| 13. LINE SAFETY MODE | 30. SECOND CLUTCH | 47. MEMORY |
| 14. REVERSE | 31. COAST FEED CLUTCH | 48. EXHAUST |
| 15. REVERSE LOCK OUT (RLO) | 32. COAST CLUTCH | 51. VENT |
| 16. REVERSE CLUTCH | 33. 23 REGULATED | 52. VOID |
| 17. LOW AND REVERSE CLUTCH | 34. SECOND COAST CLUTCH | 53. CONVERTER FDL |
| 18. LOW/REV CLUTCH OR RLO | 35. INTERMEDIATE CLUTCH | 54. ACCUMULATOR |

Copyright © 2002 ATSG

Figure 24

TRANSMISSION DISASSEMBLY

EXTERNAL COMPONENTS

1. Install transmission Holding Fixture J-8763-02 or equivalent that will allow you to mount the transmission in a bench fixture and rotate it to a desired position for disassembly, as shown in Figure 25.
2. Remove the torque converter assembly from transmission as shown in Figure 26, by pulling straight out and rotating until dis-engaged from the transmission.

Caution: The Torque Converter weighs approximately 26 pounds.

3. Remove and discard the "O" ring from turbine shaft, as shown in Figure 27, using a small screwdriver.

Continued on Page 28

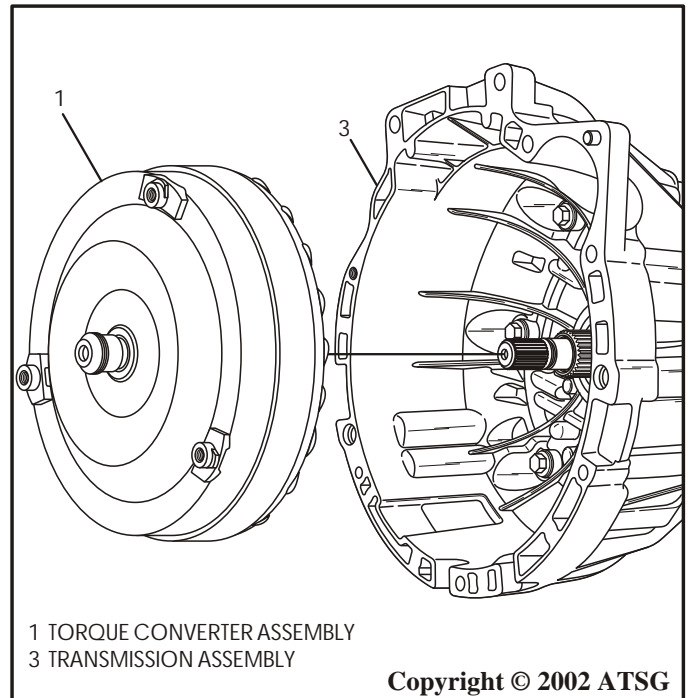

Figure 26

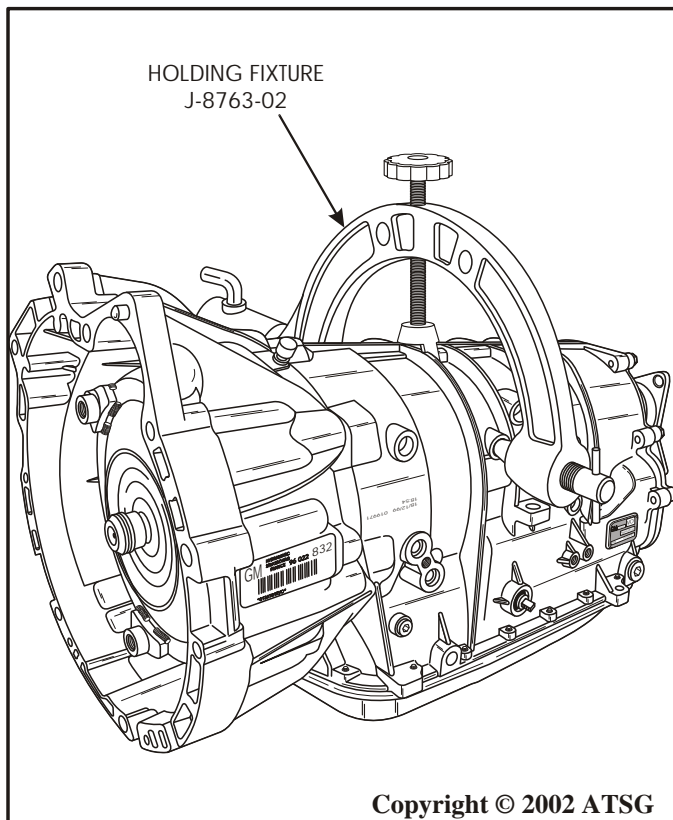

Figure 25

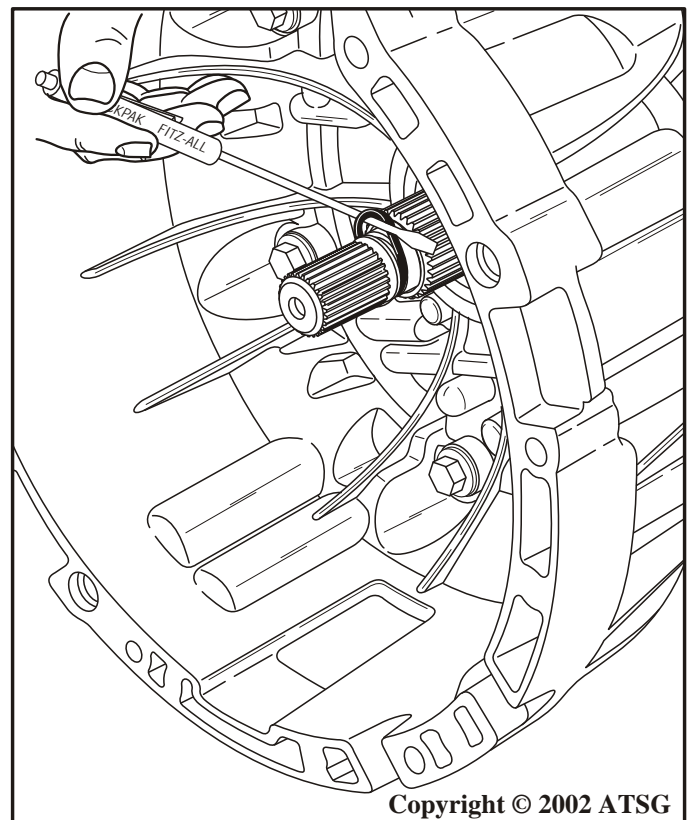

Figure 27



Technical Service Information

Continued From Page 27

4. Remove the drain plug from the bottom pan, as shown in Figure 28, and allow fluid to drain.
5. Rotate the transmission in fixture so extension housing is facing up, as shown in Figure 30.
6. Put transmission into Park and remove the prop shaft flange nut and washer (See Figure 30)
7. Remove the driveshaft yoke from transmission output shaft, as shown in Figure 30.
8. Remove and discard the "O" ring seal from the inside groove of the driveshaft yoke, as shown in Figure 29.

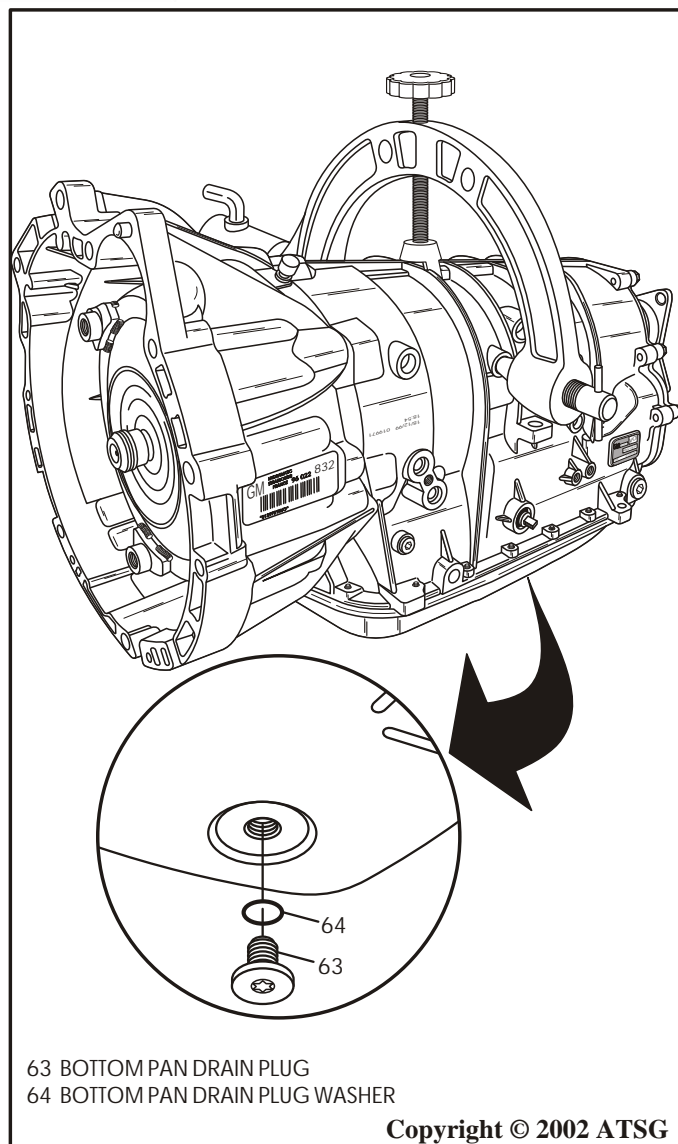

Figure 28

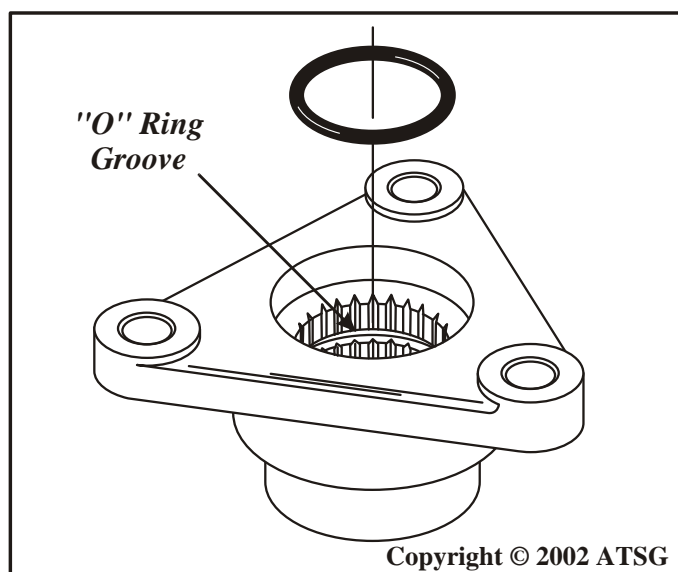

Figure 29

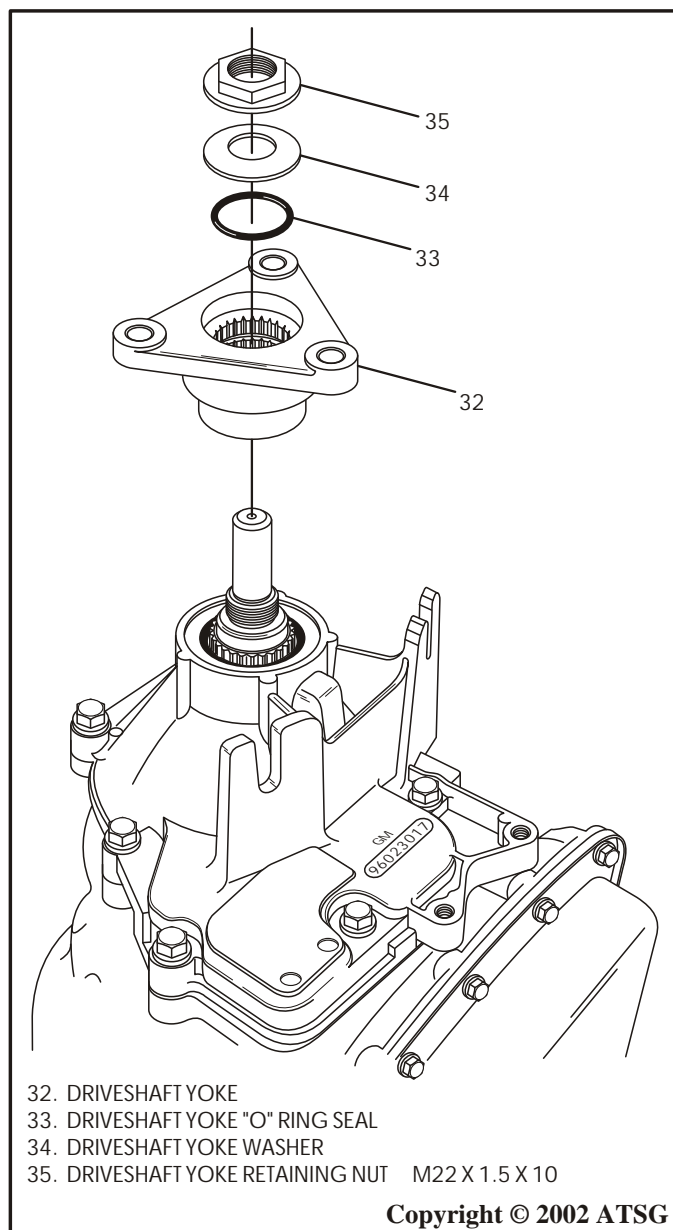

Figure 30



Technical Service Information

9. Remove the seven extension housing to case retaining bolts, as shown in Figure 32.
 10. Remove the extension housing assembly, as shown in Figure 32.
 11. Remove and discard the extension housing gasket, as shown in Figure 32.
 12. Remove the output shaft to extension housing thrust washer (27) that may be on the output shaft, or stuck to the extension housing thrust bearing. Refer to Figures 31 and 32.
- Note: This thrust washer is selective.**
13. Remove the thrust bearing which is hand pressed into the extension housing, as shown in Figure 31.
 14. Remove and discard the extension housing driveshaft yoke seal, as shown in Figure 31
 15. Set extension housing aside for sub-assembly and rotate transmission slowly so that output shaft is facing down, to drain any access fluid.

Continued on Page 32

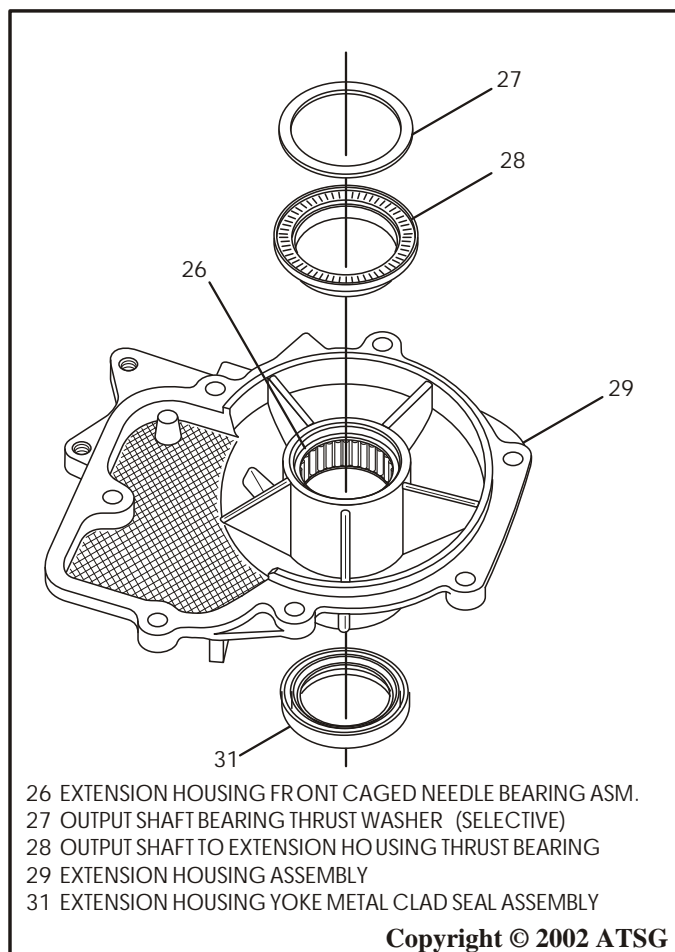

Figure 31

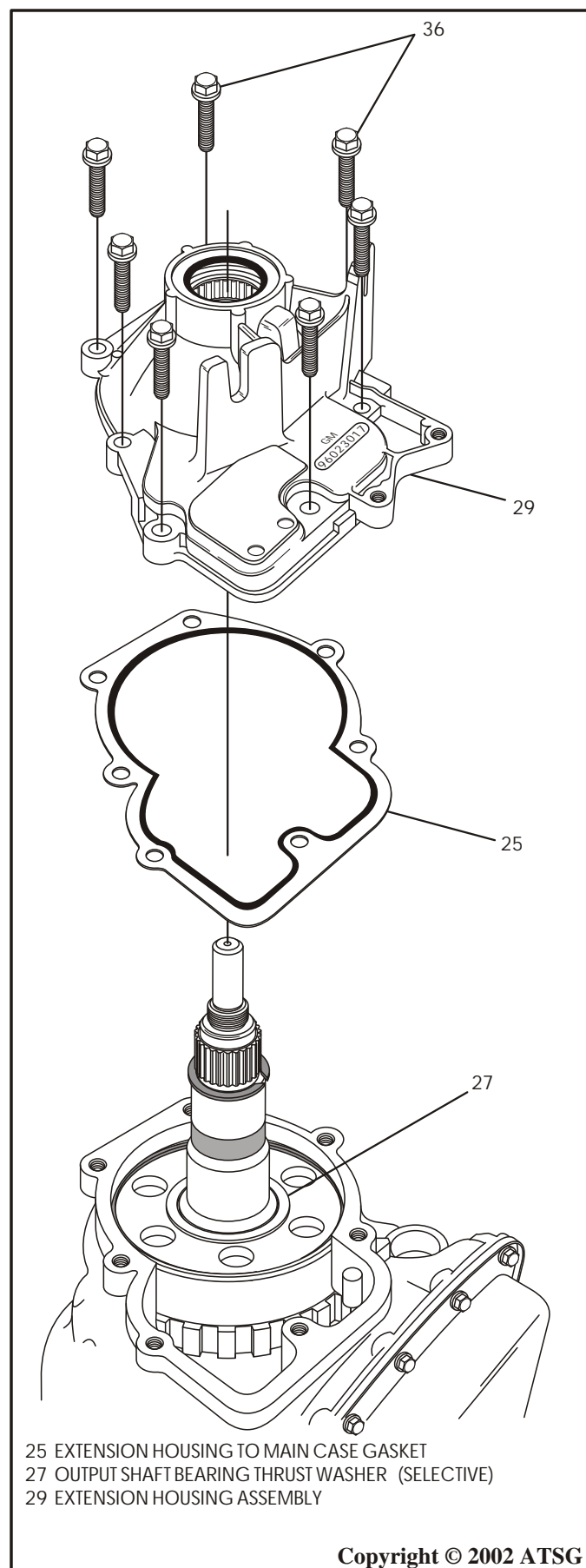
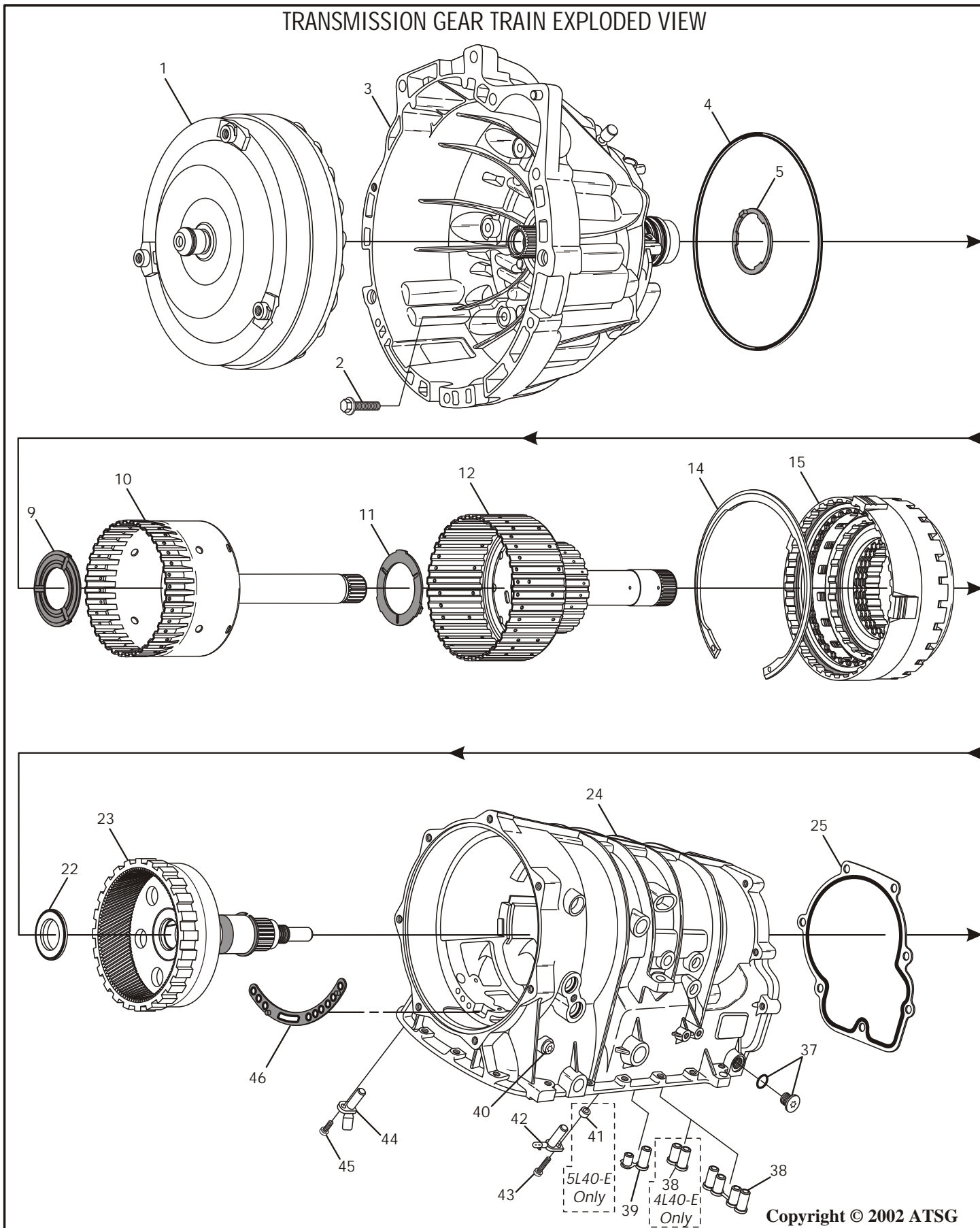

Figure 32



Technical Service Information

TRANSMISSION GEAR TRAIN EXPLODED VIEW



Copyright © 2002 ATSG

Figure 33



Technical Service Information

TRANSMISSION GEAR TRAIN EXPLODED VIEW

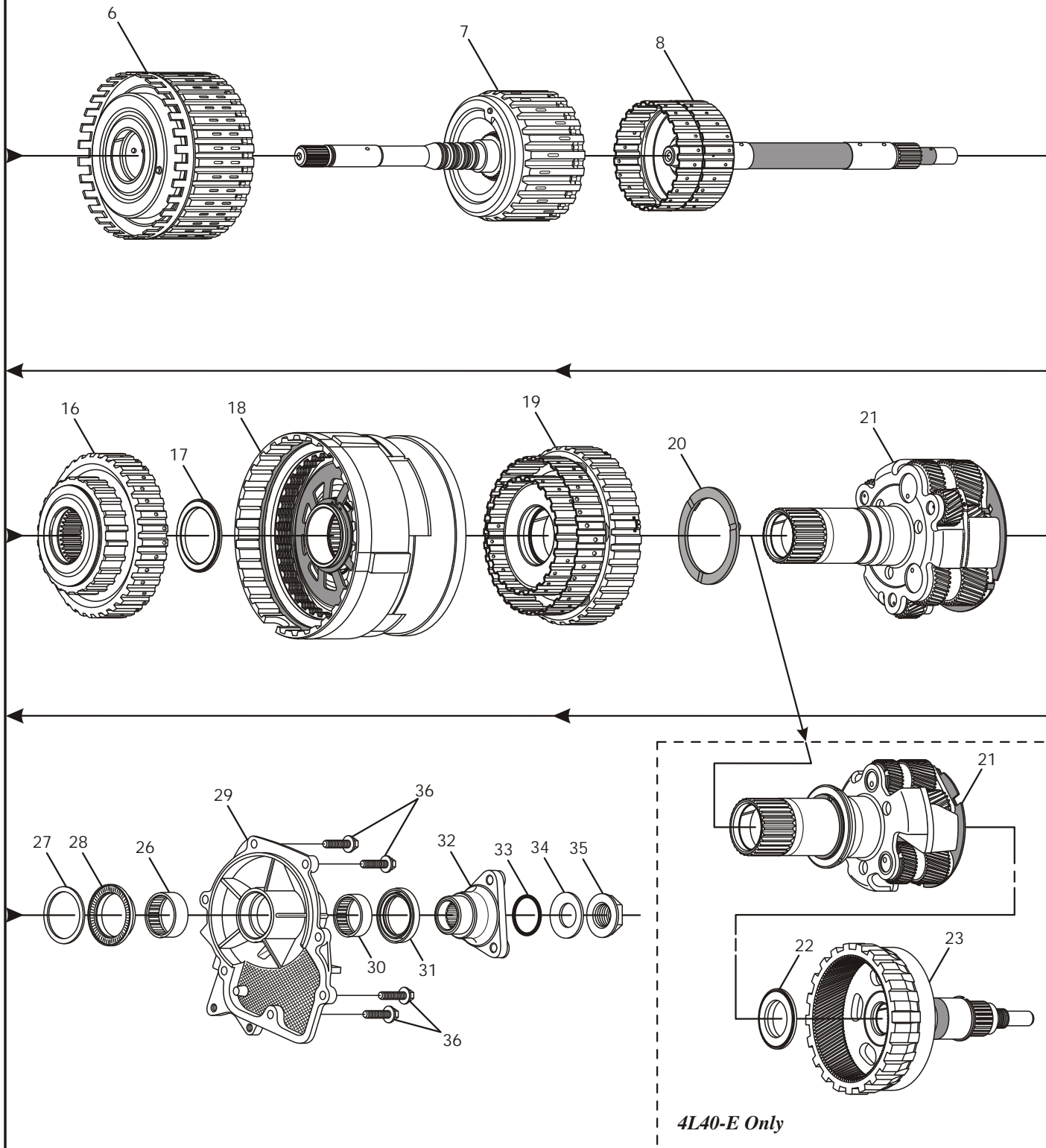

Copyright © 2002 ATSG

Figure 34



Technical Service Information

Legend For Figures 33 and 34

- 1 TORQUE CONVERTER ASSEMBLY (MODEL SENSITIVE)
- 2 TORQUE CONVERTER HOUSING TO MAIN CASE BOLTS (7)
- 3 CONVERTER HOUSING AND OIL PUMP ASSEMBLY
- 4 CONVERTER HOUSING TO MAIN CASE "D" RING SEAL
- 5 REVERSE CLUTCH HOUSING THRUST WASHER (SELECTIVE)
- 6 DIRECT AND REVERSE CLUTCH HOUSING ASSEMBLY
- 7 FORWARD AND COAST CLUTCH HOUSING ASSEMBLY
- 8 FORWARD SPRAG ASSEMBLY AND INPUT SUN GEAR SHAFT
- 9 DIRECT CLUTCH HUB THRUST WASHER
- 10 DIRECT CLUTCH HUB AND SHAFT ASSEMBLY
- 11 DIRECT CLUTCH HUB TO O.D. CLUTCH HUB THRUST WASHER
- 12 O.D. CLUTCH HUB AND INTERMEDIATE SPRAG ASSEMBLY
- 14 INTERM. AND O.D. CLUTCH HOUSING SNAP RING (SELECTIVE)
- 15 INTERMEDIATE AND OVERDRIVE CLUTCH HOUSING ASSEMBLY
- 16 LOW SPRAG ASSEMBLY
- 17 LOW SPRAG TO CENTER SUPPORT THRUST BEARING
- 18 CENTER SUPPORT ASSEMBLY
- 19 2ND CLUTCH SPRAG AND HUB ASSEMBLY (5L40-E ONLY)
- 20 2ND CLUTCH SPRAG THRUST WASHER (5L40-E ONLY)
- 21 PLANETARY CARRIER ASSEMBLY
- 22 PLANETARY CARRIER TO OUTPUT SHAFT THRUST BEARING
- 23 OUTPUT SHAFT AND INTERNAL RING GEAR ASSEMBLY
- 24 TRANSMISSION MAIN CASE ASSEMBLY
- 25 EXTENSION HOUSING TO MAIN CASE GASKET
- 26 FRONT CAGED NEEDLE BEARING IN EXTENSION HOUSING
- 27 OUTPUT SHAFT TO EXT. HSG. BEARING WASHER (SELECTIVE)
- 28 OUTPUT SHAFT TO EXTENSION HOUSING THRUST BEARING
- 29 EXTENSION HOUSING ASSEMBLY
- 30 REAR CAGED NEEDLE BEARING IN EXTENSION HOUSING
- 31 EXTENSION HOUSING YOKE SEAL ASSEMBLY
- 32 DRIVESHAFT YOKE ASSEMBLY
- 33 OUTPUT SHAFT TO YOKE "O" RING SEAL
- 34 DRIVESHAFT YOKE RETAINING WASHER
- 35 DRIVESHAFT YOKE RETAINING NUT
- 36 EXTENSION HOUSING RETAINING BOLTS (7)
- 37 TRANSMISSION FILL PLUG AND "O" RING
- 38 CENTER SUPPORT OIL PASSAGE SLEEVE AND SEAL ASSEMBLY
- 39 O.D./INTERMEDIATE OIL PASSAGE SLEEVE AND SEAL ASSEMBLY
- 40 TRANSMISSION PRESSURE TEST PLUG
- 41 OUTPUT SPEED SENSOR SPACER
- 42 OUTPUT SPEED SENSOR
- 43 OUTPUT SPEED SENSOR RETAINING BOLT
- 44 INPUT SPEED SENSOR
- 45 INPUT SPEED SENSOR RETAINING BOLT
- 46 PUMP COVER TO MAIN CASE MOLDED GASKET

TRANSMISSION DISASSEMBLY (CONT'D)

BOTTOM PAN COMPONENTS

16. Rotate transmission in fixture so that bottom pan is facing up, as shown in Figure 35.
17. Remove the 20 bottom pan retaining bolts, as shown in Figure 35, and remove oil pan.
18. Ensure that bottom pan magnet is stuck in position in bottom pan (See Figure 35).
19. Remove and discard bottom oil pan gasket, as shown in Figure 35.

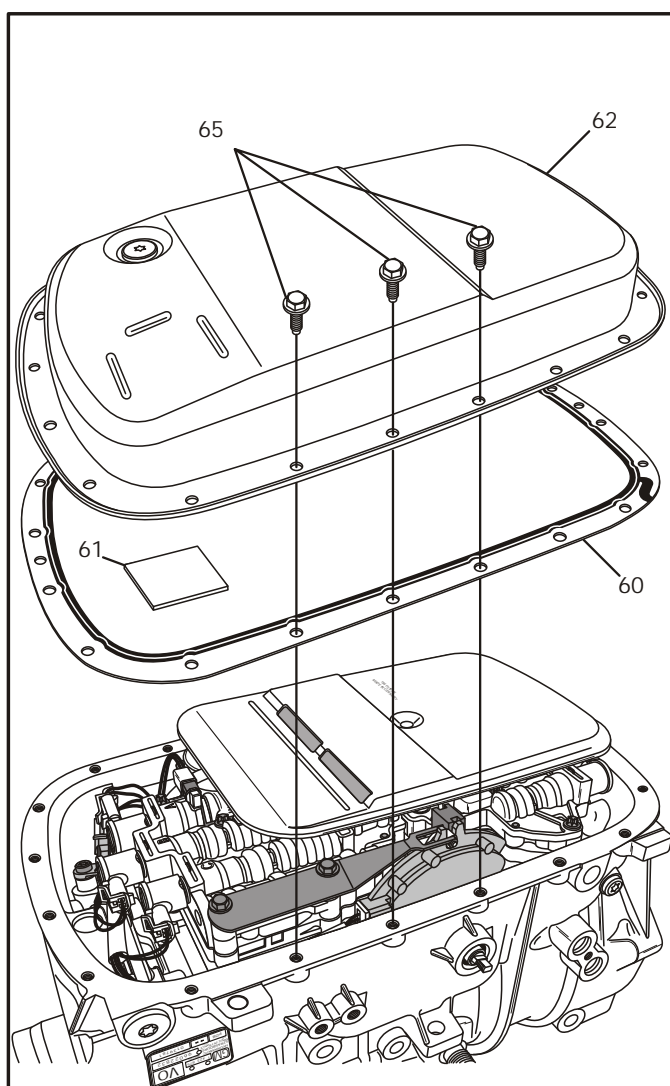

- 60 BOTTOM OIL PAN GASKET
- 61 BOTTOM OIL PAN MAGNET
- 62 BOTTOM OIL PAN
- 65 BOTTOM OIL PAN BOLTS (20 REQUIRED)

Copyright © 2002 ATSG

Figures 33 and 34 Legend

Figure 35



Technical Service Information

20. Remove and discard the bottom pan oil filter, as shown in Figure 36.
21. Remove the oil filter spacer, if used, and store in a safe place for transmission re-assembly (See Figure 36).
22. The oil filter seals, will remain in the oil pump cover and will probably have to be removed with a slide hammer and attachment.
23. Notice that there are two filter seals used with this unit, as shown in Figure 36.
24. Remove and discard the two oil filter seals at this time, using the proper tools.
25. Remove transmission case connector retainer with a screwdriver and push case connector back into the transmission case to make ready for wiring harness removal (See Figure 37).

Continued on Page 34

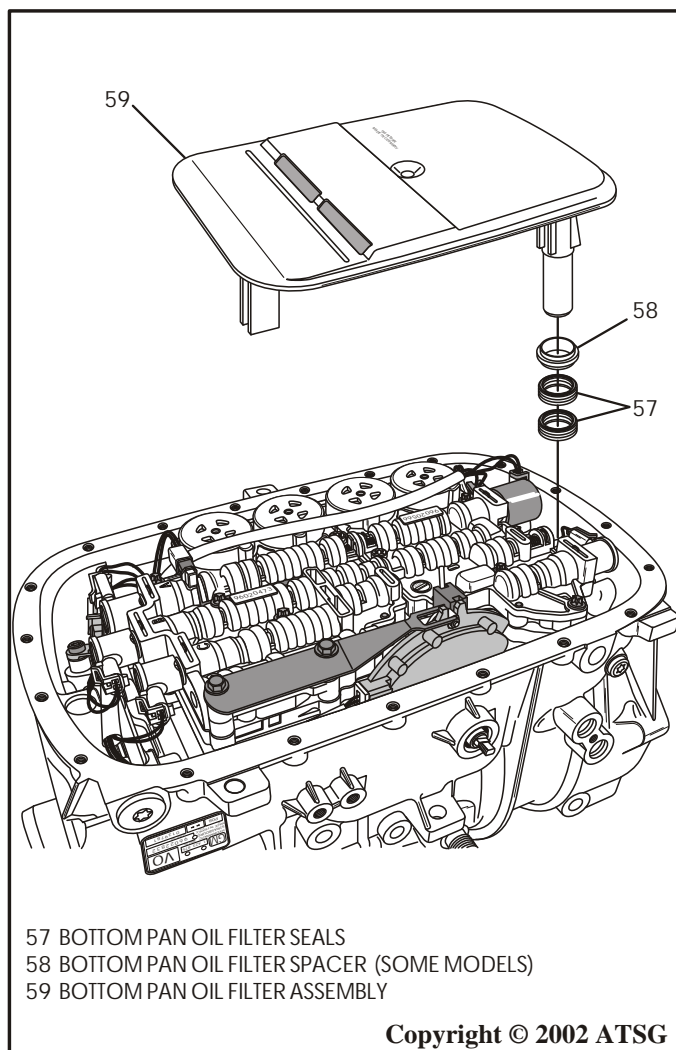

Figure 36

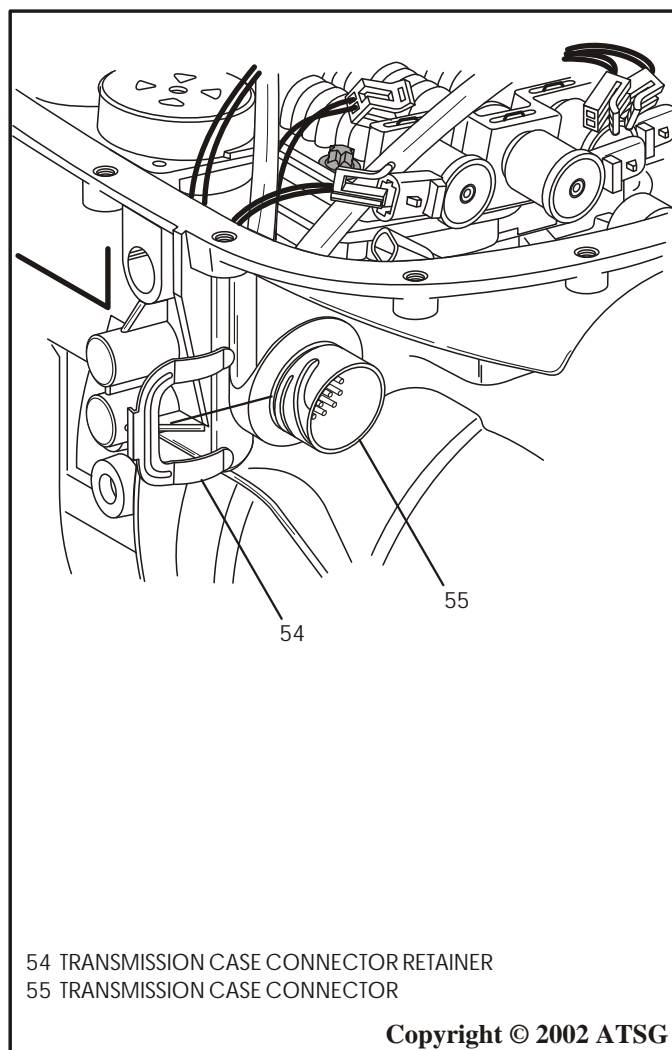

Figure 37



Technical Service Information

TRANSMISSION DISASSEMBLY (CONT'D)

BOTTOM PAN COMPONENTS

26. Using a small screwdriver, carefully remove the wire harness connectors from all of the following components: (See Figure 38)
 - o Pressure Control Solenoid
 - o TCC/PWM Solenoid
 - o Input Shaft Speed Sensor
 - o 1-2 Shift Solenoid
 - o 2-3 Shift Solenoid
 - o 4-5 Shift Solenoid
 - o Output Shaft Speed Sensor
 - o Internal Mode Switch
 - o TFT Sensor from Bracket
27. Remove the Internal Wiring Harness assembly from the transmission, as shown in Figure 38, and set aside for component rebuild.
28. Remove only the nine valve body bolts that are called out in Figure 41.
29. Remove the valve body assembly from the case as shown in Figure 39, and set aside for the component rebuild section.
30. Remove and discard the valve body seals from the case, as shown in Figure 40.

Continued on Page 36

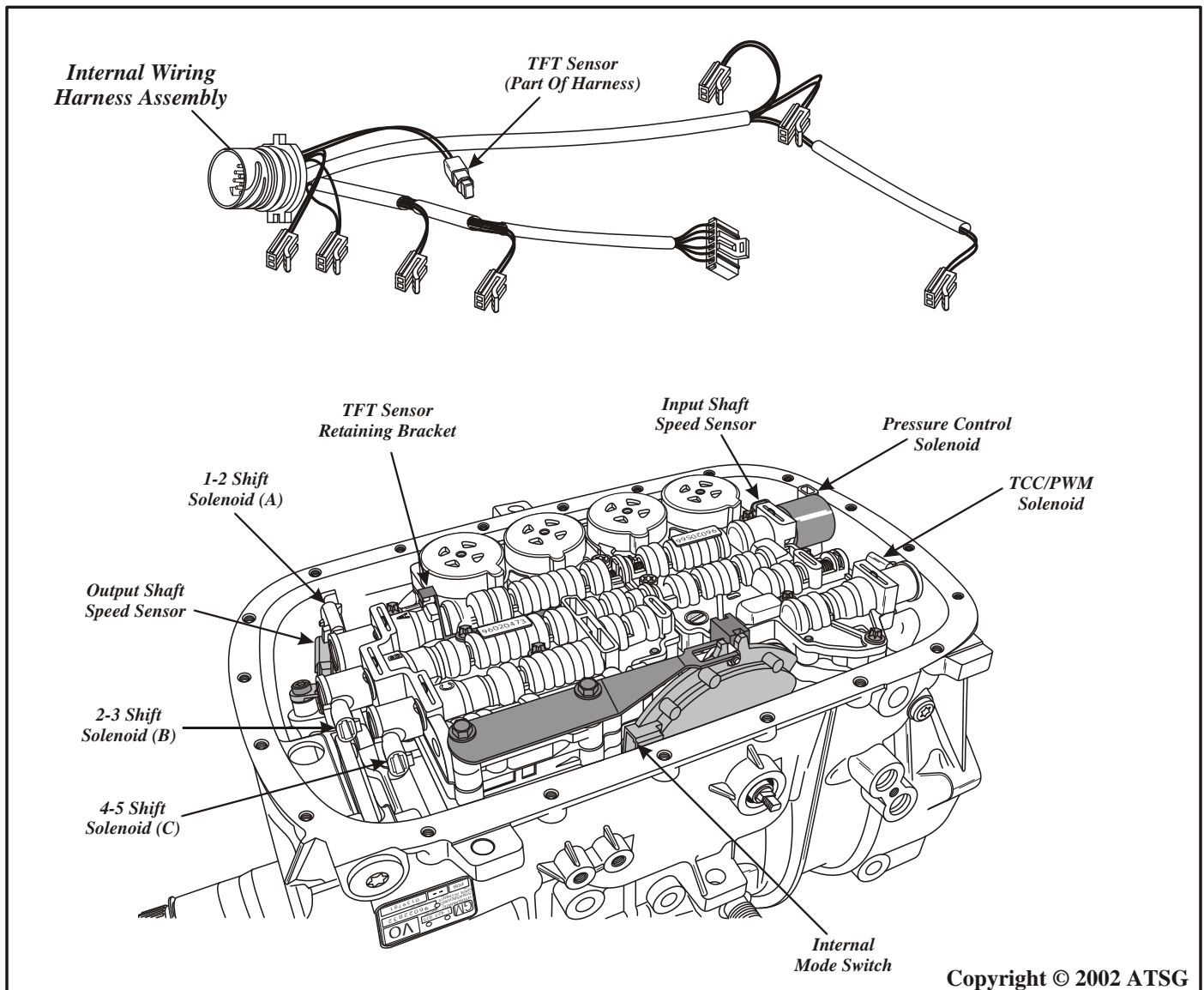

Figure 38



Technical Service Information

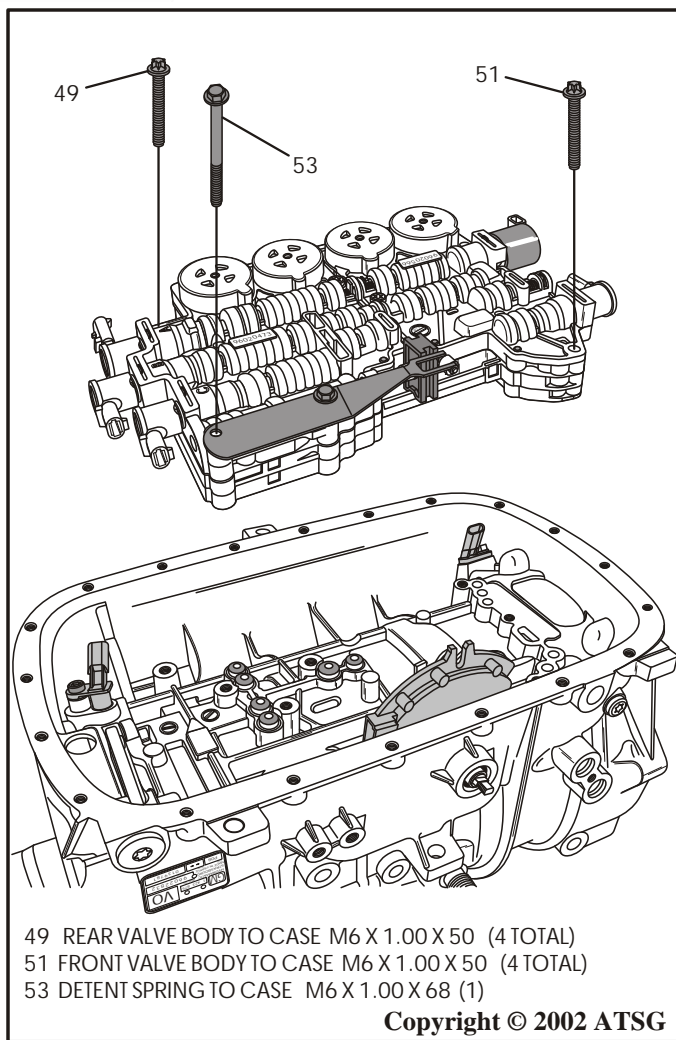

Figure 39

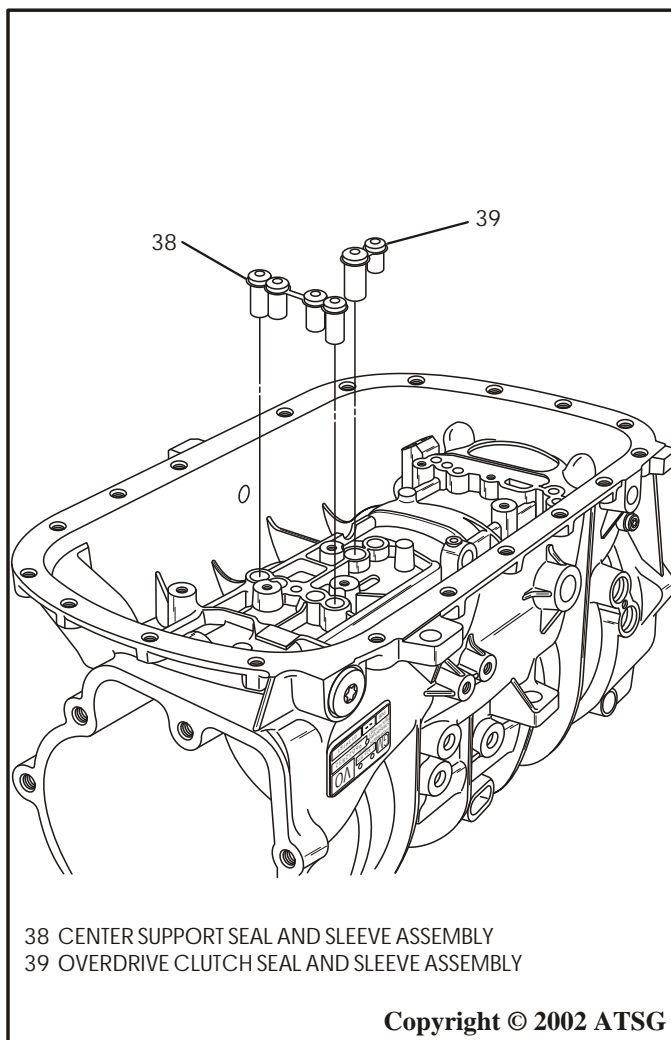

Figure 40

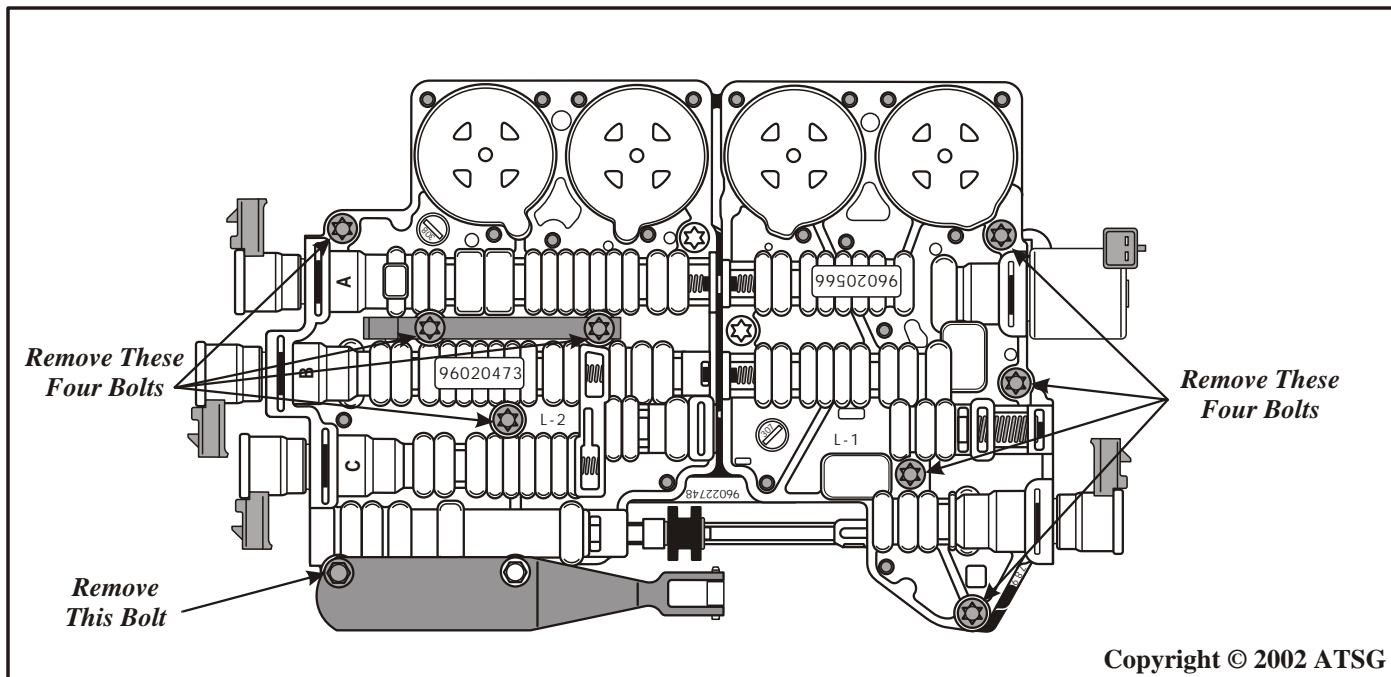

Figure 41



Technical Service Information

TRANSMISSION DISASSEMBLY (CONT'D)

BOTTOM PAN COMPONENTS

31. Remove input speed sensor retaining bolt and input speed sensor, as shown in Figure 42.
32. Remove output speed sensor retaining bolt, output speed sensor spacer and output speed sensor, as shown in Figure 43.

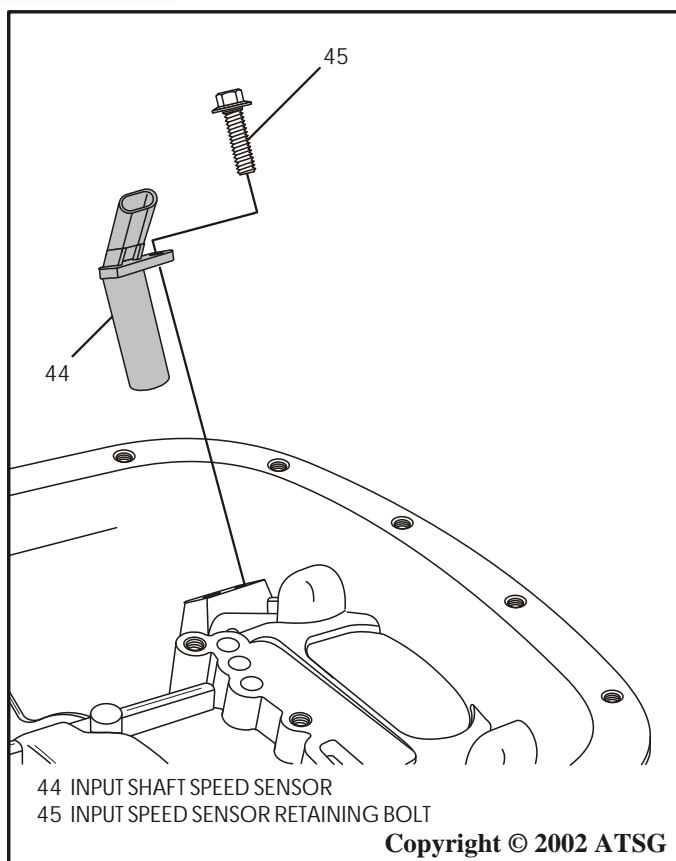

Figure 42

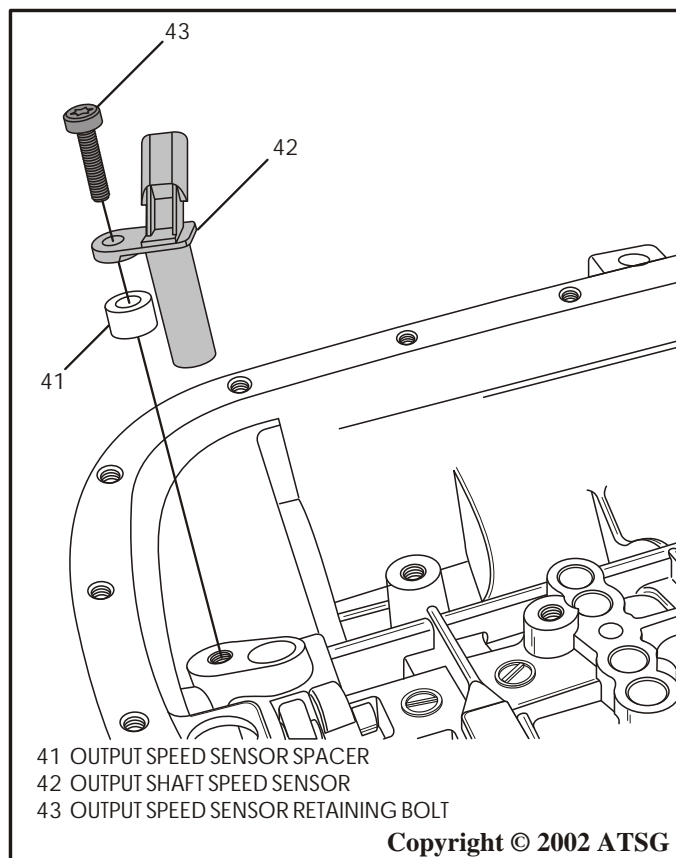

Figure 43

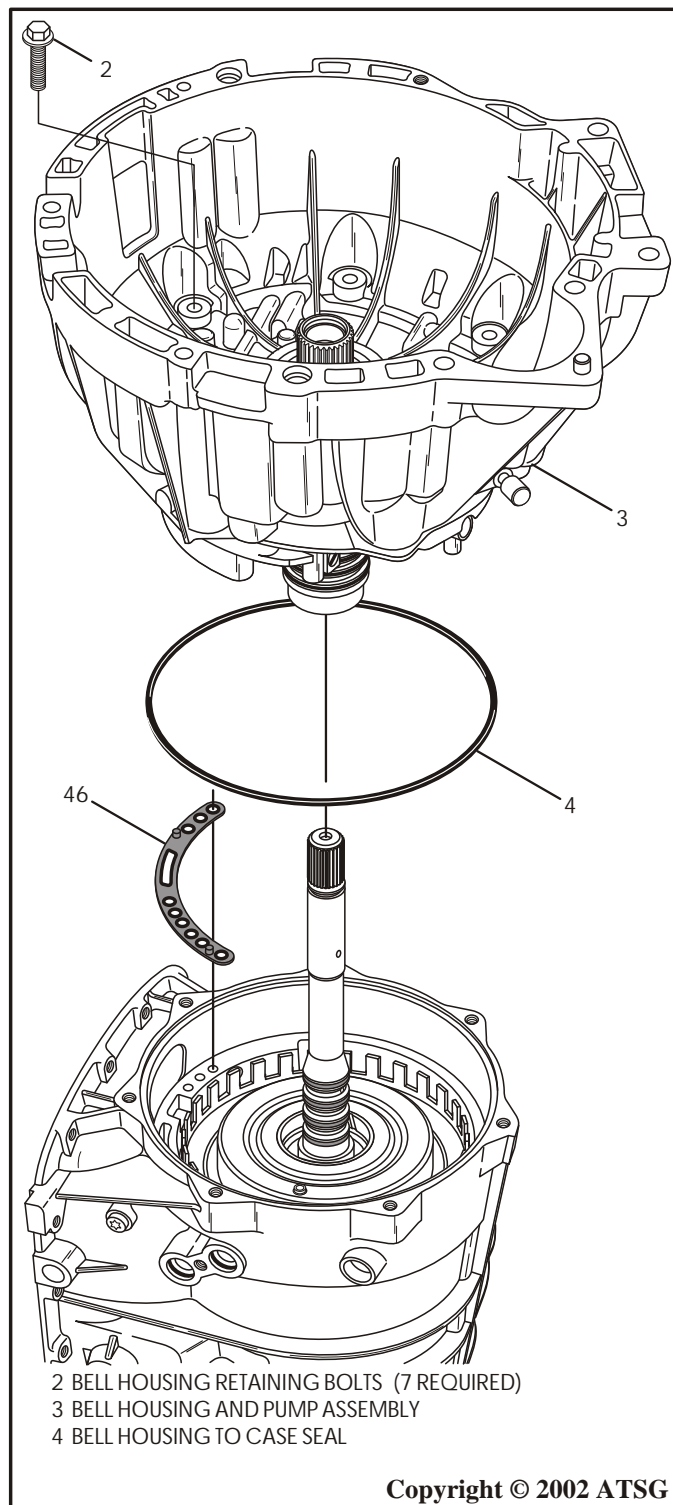

Figure 44



Technical Service Information

TRANSMISSION DISASSEMBLY (CONT'D)

INTERNAL COMPONENTS

33. Remove the 7 bell housing to case retaining bolts, as shown in Figure 44.
34. Remove bell housing and oil pump assembly, as shown in Figure 44 and set aside for the component rebuild process.
35. Remove and discard the bell housing to case seal and the pump cover to case gasket, as shown in Figure 44.
36. Remove the forward clutch housing and reverse clutch housing as an assembly by grasping the turbine shaft and lifting straight up, as shown in Figure 45.

37. Separate the reverse clutch housing from the forward clutch housing, as shown in Figure 46, and set aside for component rebuild process.

Continued on Page 38

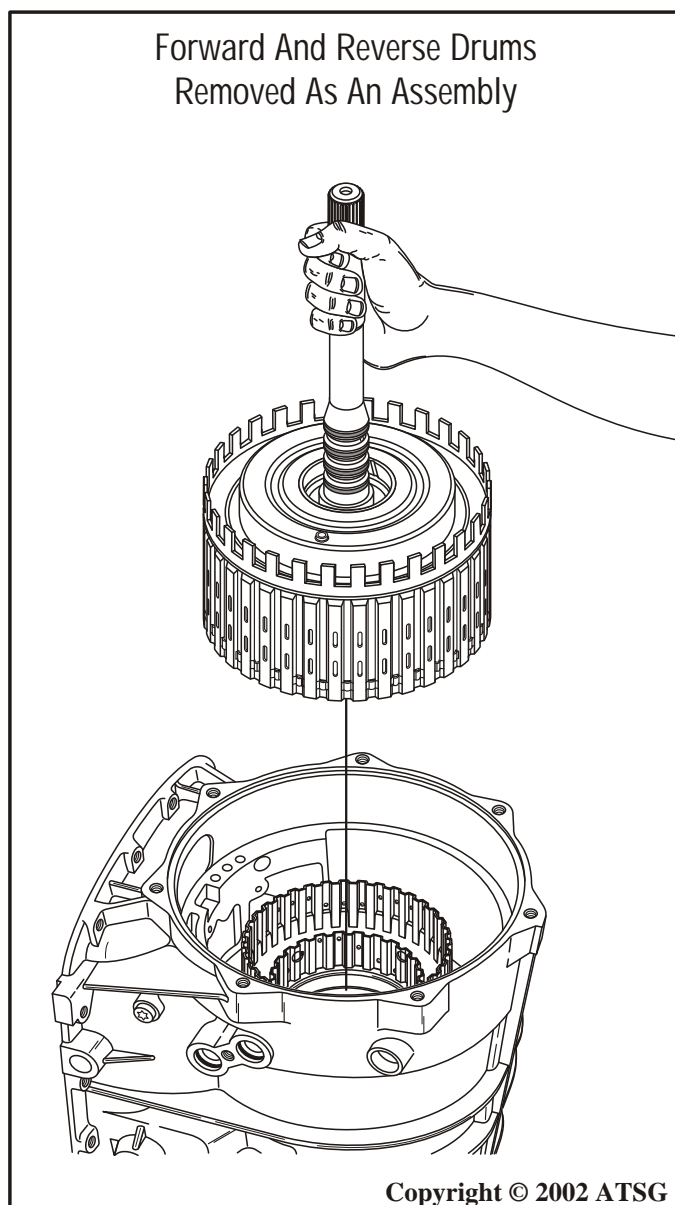

Figure 45

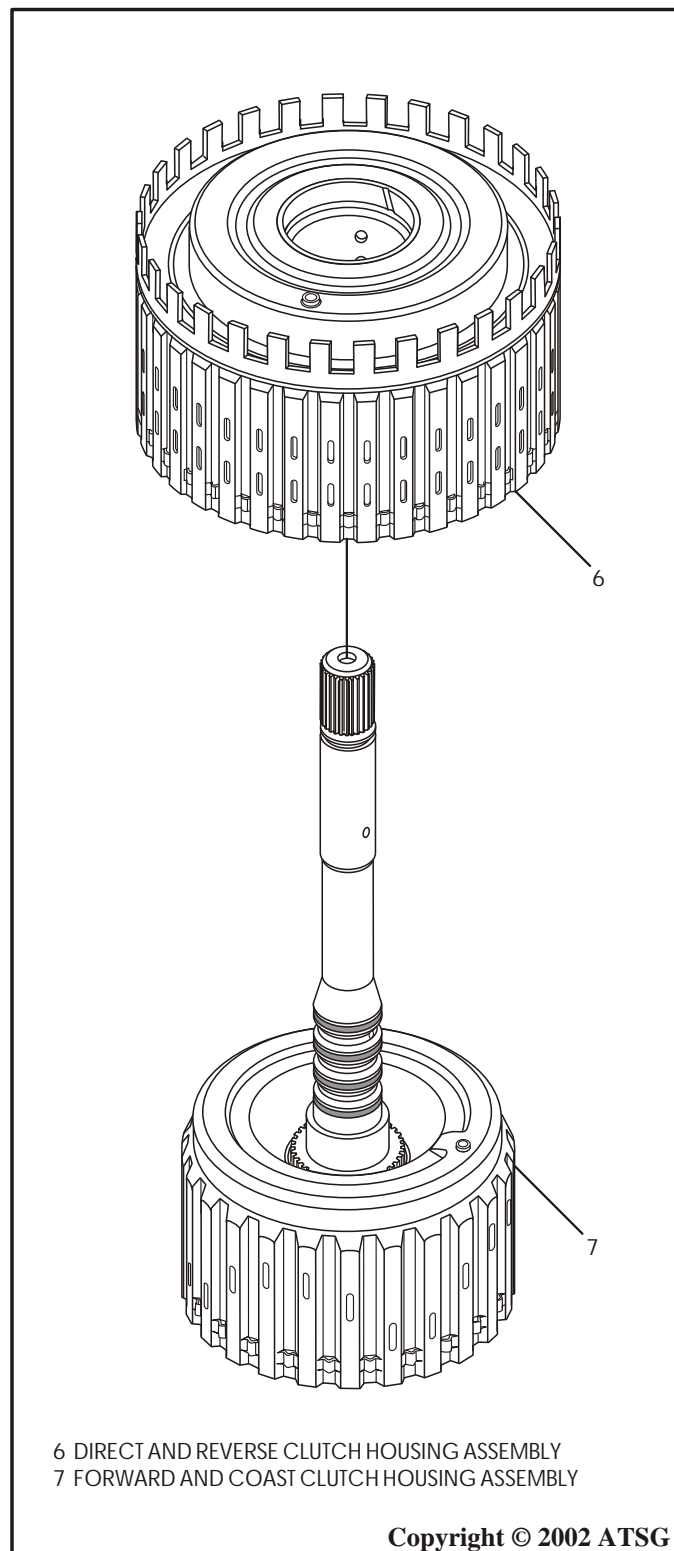

Figure 46



Technical Service Information

TRANSMISSION DISASSEMBLY (CONT'D)

INTERNAL COMPONENTS

38. Remove the input sun gear shaft and forward sprag assembly by lifting straight up, as shown in Figure 47, and set the assembly aside for the component rebuild section.
39. Remove the direct clutch hub and the thrust washer from the case, as shown in Figure 48.
40. Remove the overdrive clutch hub and thrust washer from the case, as shown in Figure 49.
41. Remove the *"Selective"* snap ring retaining the overdrive clutch housing in the case, using the Snap Ring Pliers J-45126 (See Figure 50).

Note: *These snap ring pliers are required to remove or install this snap ring as they have long handles and are locking.*

42. Use caution when removing or installing this snap ring, as the snap ring is very thick and very strong. Ensure that you have the J-45126 snap ring pliers engaged properly, as shown in Figure 50.
43. Remove the overdrive clutch housing from the case, as shown in Figure 50, and set aside for the component rebuild section.

Continued on Page 40

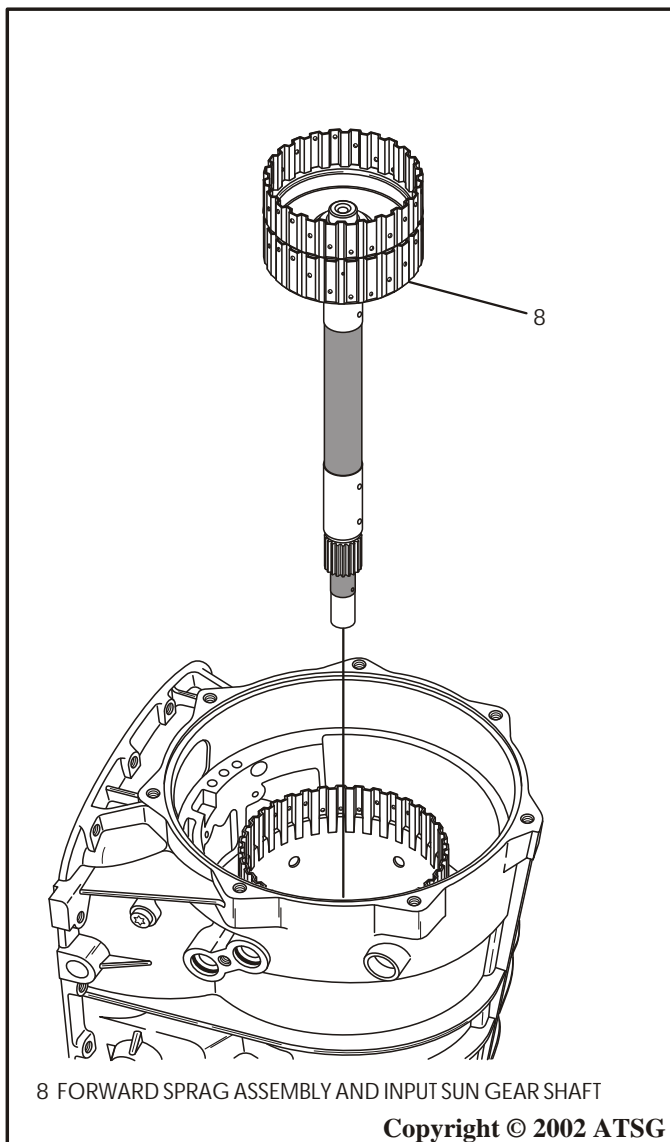

Figure 47

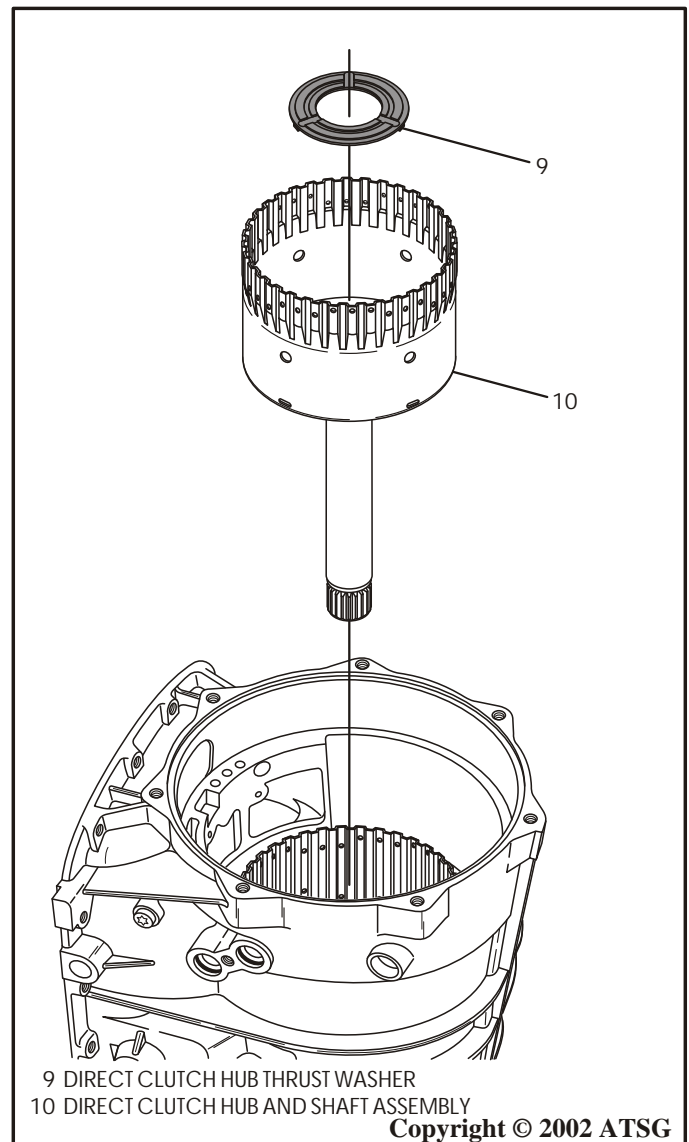
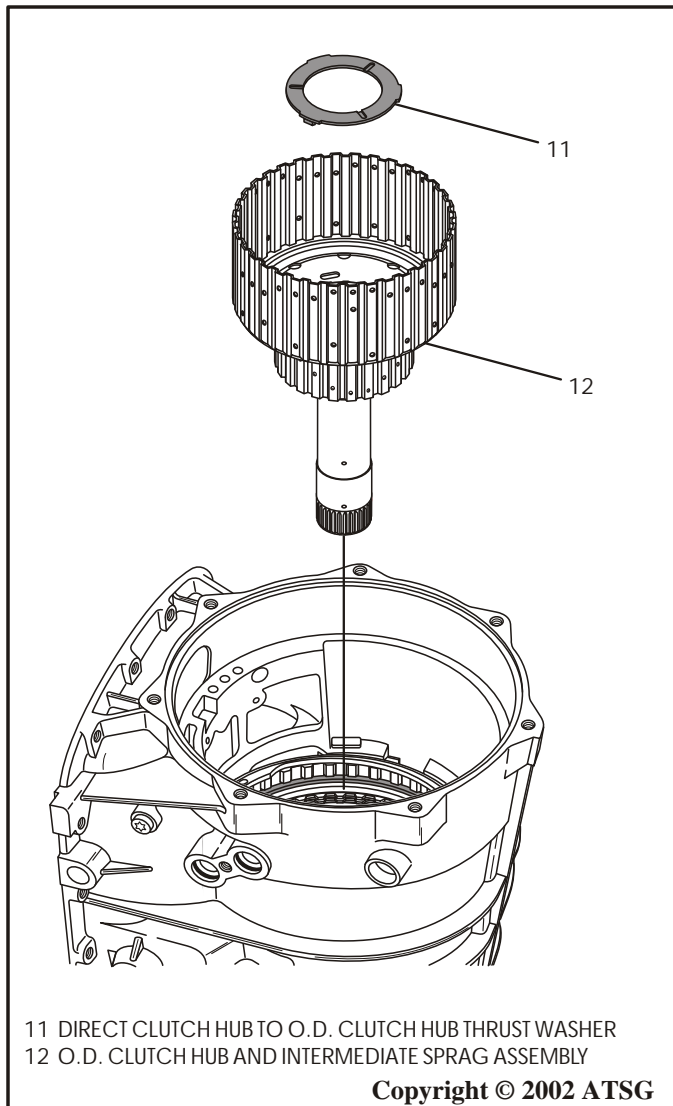
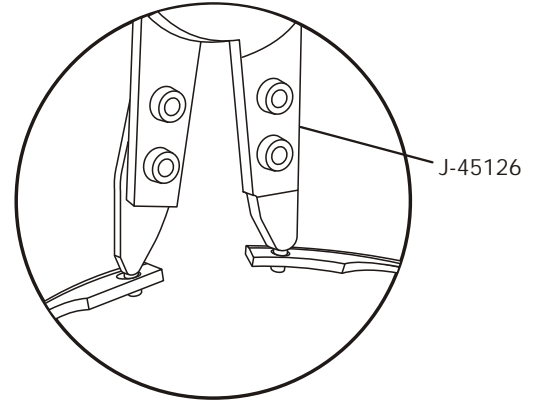

Figure 48

Snap Ring Pliers J-45126 Are "Required" To Remove Or Replace This Snap Ring

Snap Ring Pliers J-45126 are long handled for leverage and locking



11 DIRECT CLUTCH HUB TO O.D. CLUTCH HUB THRUST WASHER
12 O.D. CLUTCH HUB AND INTERMEDIATE SPRAG ASSEMBLY

Copyright © 2002 ATSG

Figure 49

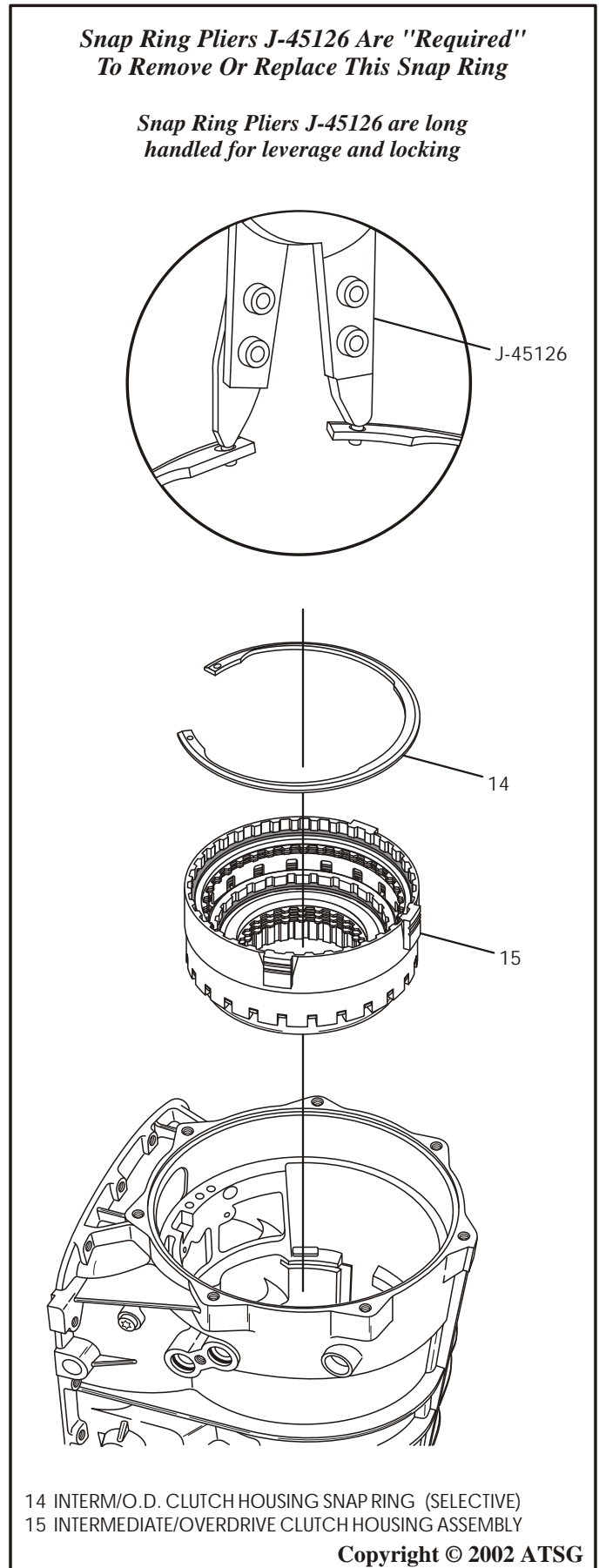

14 INTERM/O.D. CLUTCH HOUSING SNAP RING (SELECTIVE)
15 INTERMEDIATE/OVERDRIVE CLUTCH HOUSING ASSEMBLY

Copyright © 2002 ATSG

Figure 50



Technical Service Information

TRANSMISSION DISASSEMBLY (CONT'D)

INTERNAL COMPONENTS

- 44. Remove the low sprag assembly and the thrust bearing, as shown in Figure 51, and set aside for component rebuild section.
- 45. Remove the center support assembly from the case, as shown in Figure 52, and set aside for the component rebuild section.
- 46. Remove the planetary gear set from the case, as shown in Figure 53, and set aside for the component rebuild section. We have illustrated both the 4L40-E and the 5L40-E in Figure 53.

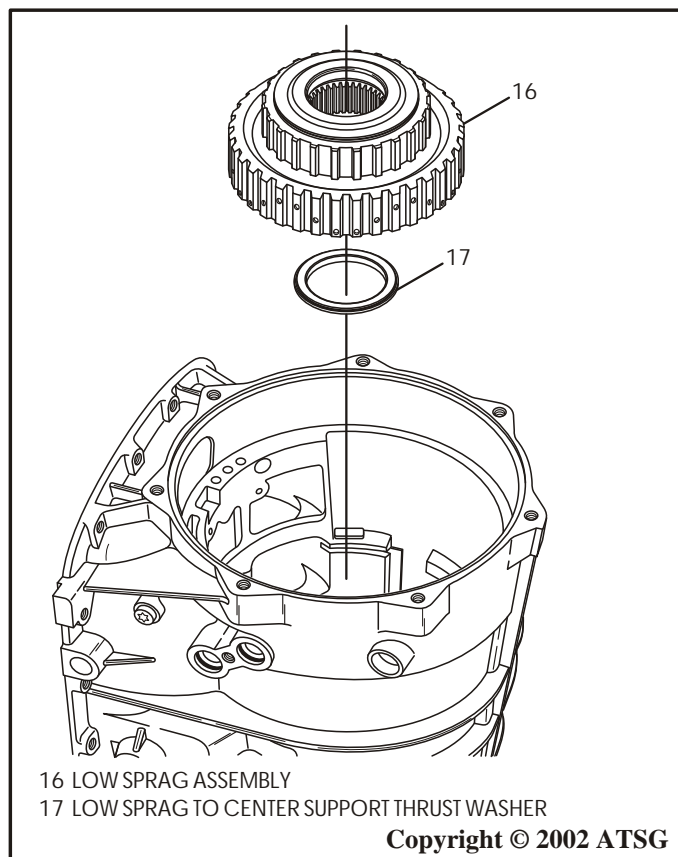

Figure 51

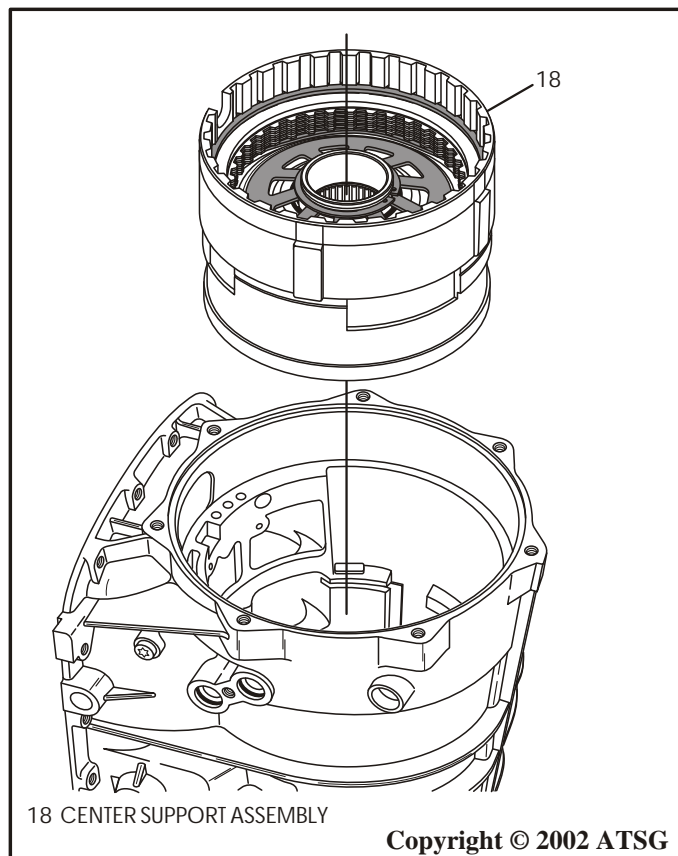

Figure 52

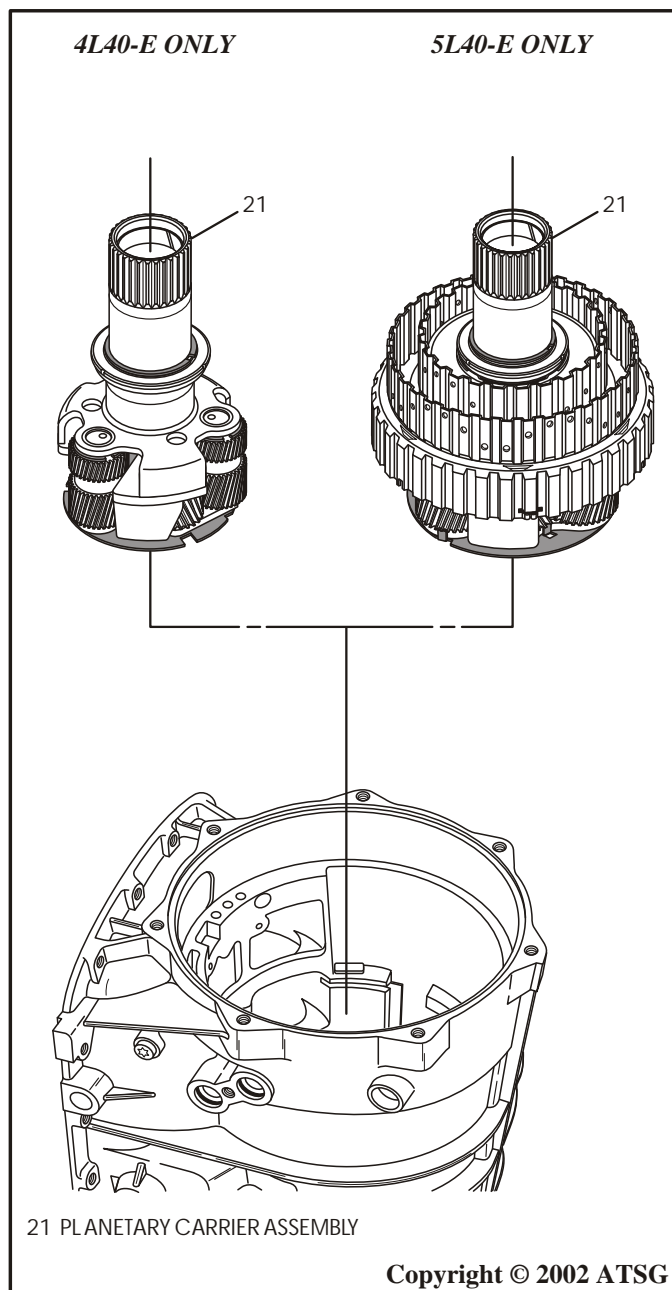

Figure 53



Technical Service Information

COMPONENT REBUILD SECTION

CASE ASSEMBLY

47. Remove the planetary internal ring gear and output shaft along with the thrust bearing, as shown in Figure 54. We have illustrated both the 4L40-E and the 5L40-E in Figure 54.
48. Rotate the transmission so that the pan surface is facing up to prepare for removing manual shaft and manual shaft seal.

1. This transmission has 2 different manual shaft configurations, as shown in Figures 55 and 56. The models shown in Figure 55 is for right hand drive vehicles and the models shown in Figure 56 is for left hand drive vehicles.
2. Use Figure 55 or Figure 56, depending on the model you are working, as a guide to remove the manual shaft to replace the manual shaft seal.
3. Inspect the transmission case for the following:
 - o Damaged threads that may need Heli-Coil®.
 - o Gasket sealing surfaces for damage.
 - o Damaged or porous fluid passages.
 - o Snap ring grooves for damage.
 - o Pressure test plug threads for damage.
 - o Fluid level plug threads for damage.
4. Clean the transmission case thoroughly and dry with compressed air.
5. Install a new manual shaft seal using the proper seal driver and re-install the manual linkage using Figure 55 or Figure 56.
6. Re-install the transmission case into the fixture and rotate so that the case front is facing up.

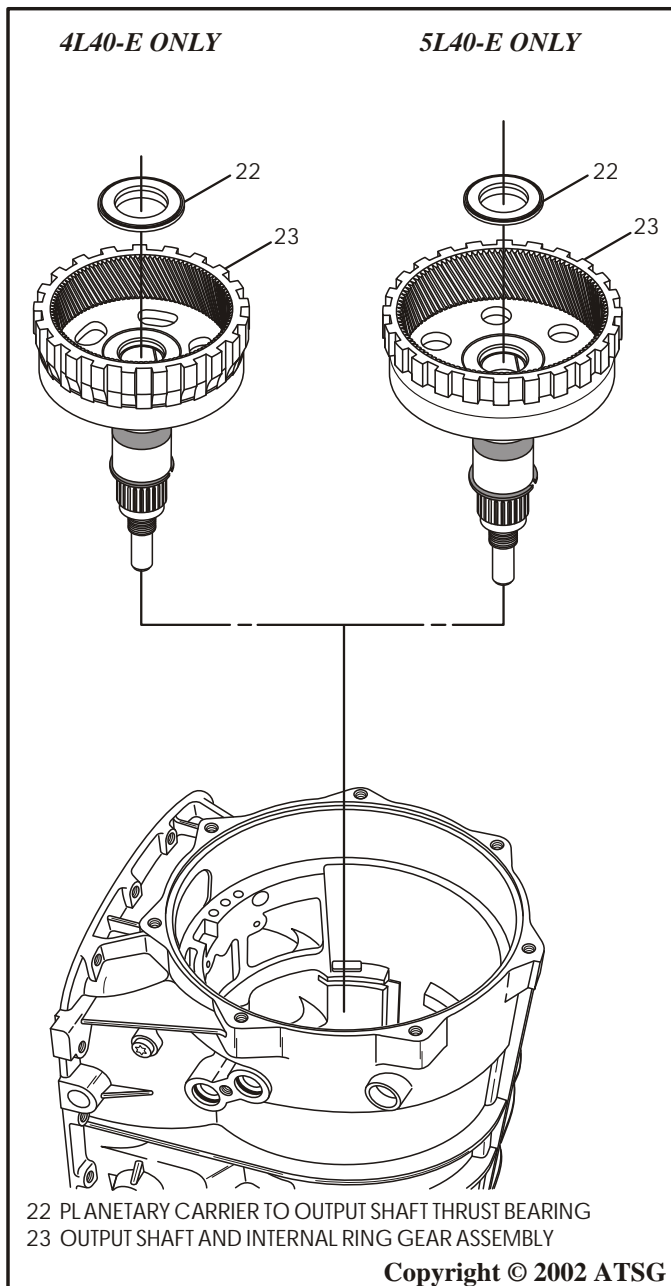

Figure 54

**Component Rebuild
Continued on Page 45**



Technical Service Information

MANUAL SHAFT ASSEMBLY "A"

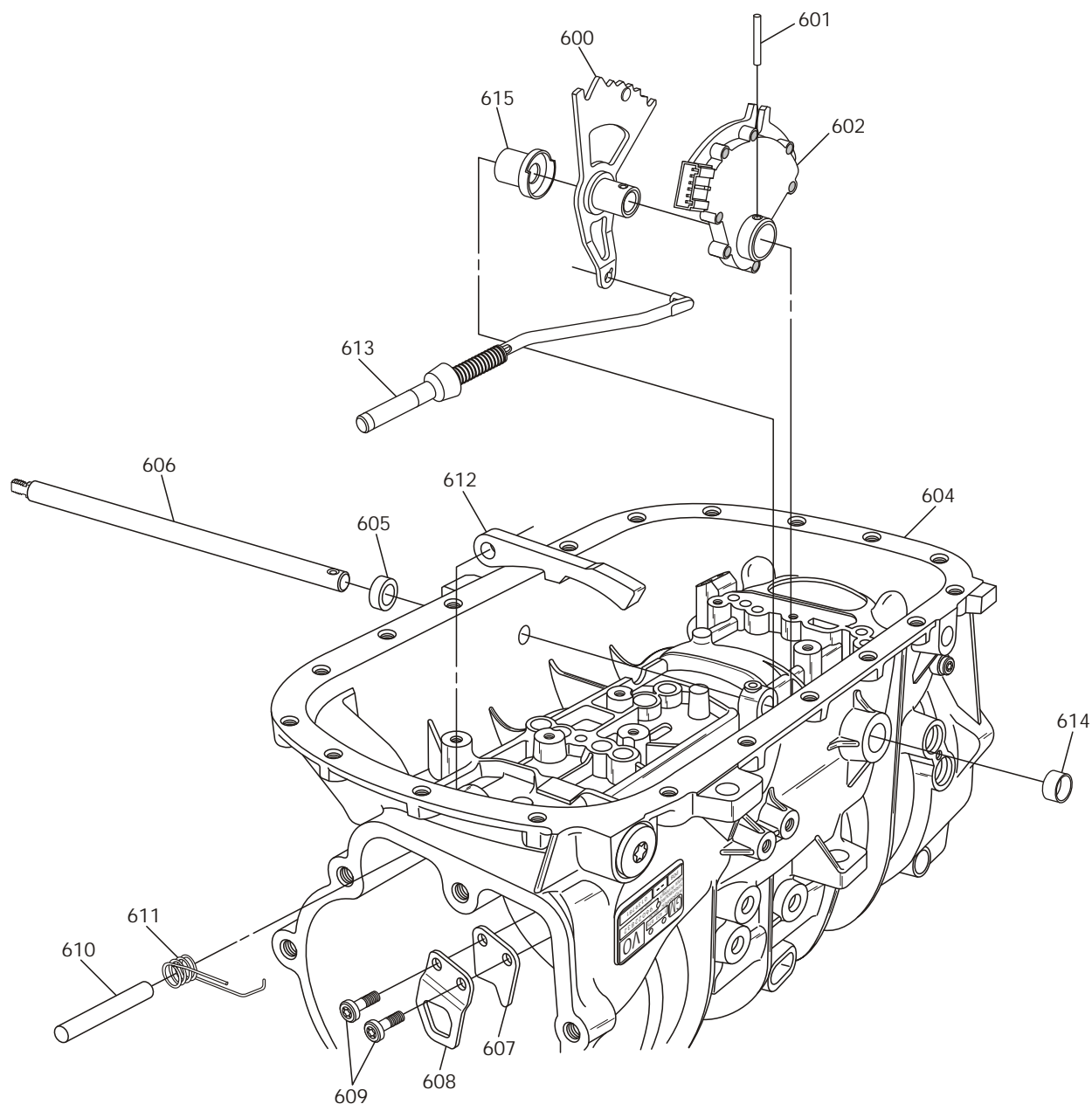

600 MANUAL SHAFT DETENT LEVER
 601 MANUAL SHAFT DETENT LEVER RETAINING PIN
 602 INTERNAL MODE SWITCH
 604 TRANSMISSION MAIN CASE ASSEMBLY
 605 MANUAL SHAFT SEAL ASSEMBLY
 606 MANUAL SHIFT SHAFT
 607 PARKING PAWL ACTUATOR BRACKET
 608 PARKING PAWL ACTUATOR BRACKET

609 PARKING PAWL ACTUATOR BRACKET BOLTS (2)
 610 PARKING PAWL PIVOT PIN
 611 PARKING PAWL RETURN SPRING
 612 PARKING PAWL
 613 PARKING PAWL ACTUATOR ROD ASSEMBLY
 614 CUP PLUG
 615 MANUAL SHAFT SPACER ASSEMBLY

Copyright © 2002 ATSG

Figure 55



Technical Service Information

MANUAL SHAFT ASSEMBLY "B"

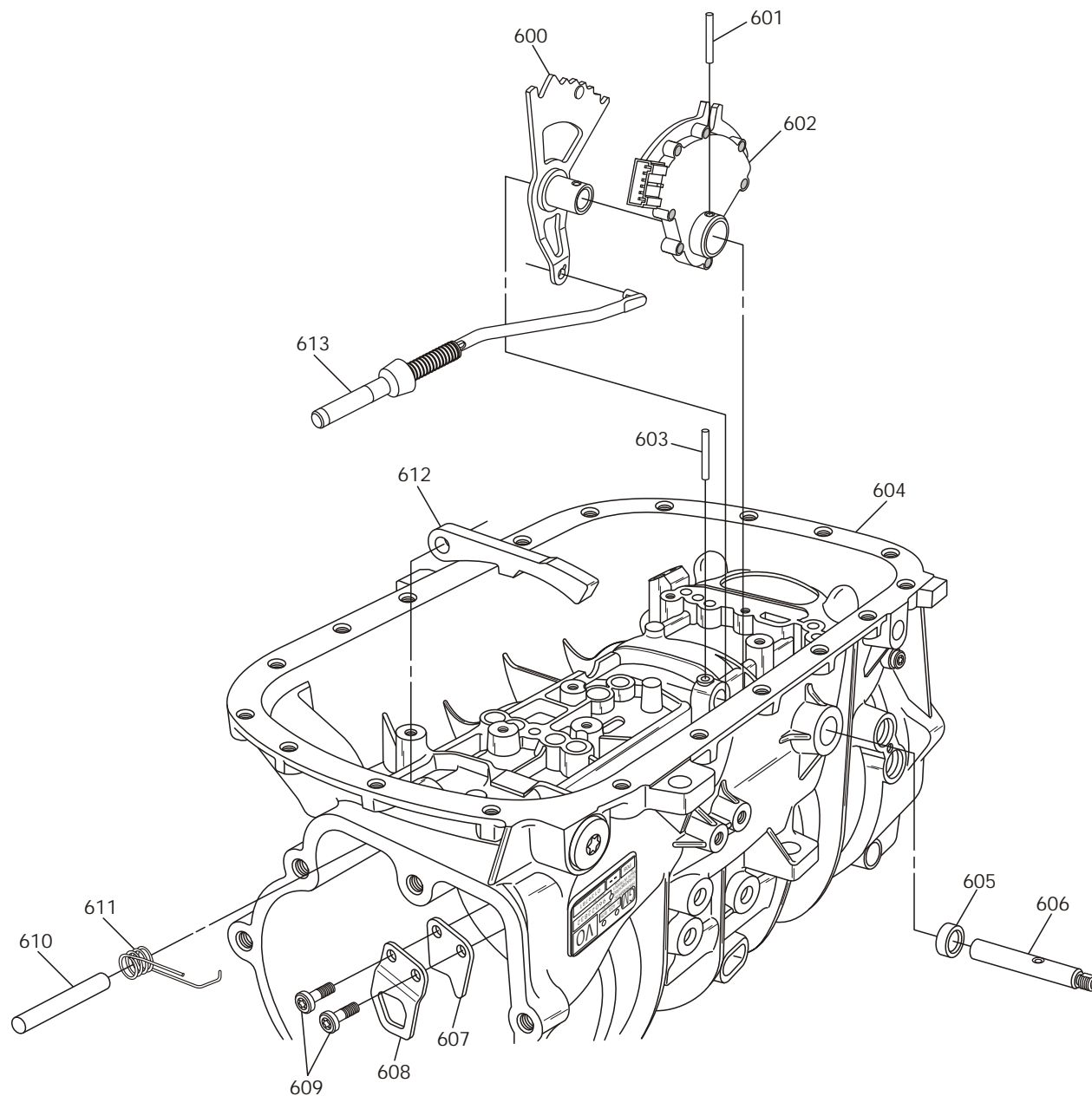

600 MANUAL SHAFT DETENT LEVER
 601 MANUAL SHAFT DETENT LEVER RETAINING PIN
 602 INTERNAL MODE SWITCH
 603 MANUAL SHAFT DETENT LEVER RETAINING PIN
 604 TRANSMISSION MAIN CASE ASSEMBLY
 605 MANUAL SHAFT SEAL ASSEMBLY
 606 MANUAL SHIFT SHAFT

607 PARKING PAWL ACTUATOR BRACKET
 608 PARKING PAWL ACTUATOR BRACKET
 609 PARKING PAWL ACTUATOR BRACKET BOLTS (2)
 610 PARKING PAWL PIVOT PIN
 611 PARKING PAWL RETURN SPRING
 612 PARKING PAWL
 613 PARKING PAWL ACTUATOR ROD ASSEMBLY

Copyright © 2002 ATSG

Figure 56



Technical Service Information

OIL PUMP COVER ASSEMBLY EXPLODED VIEW

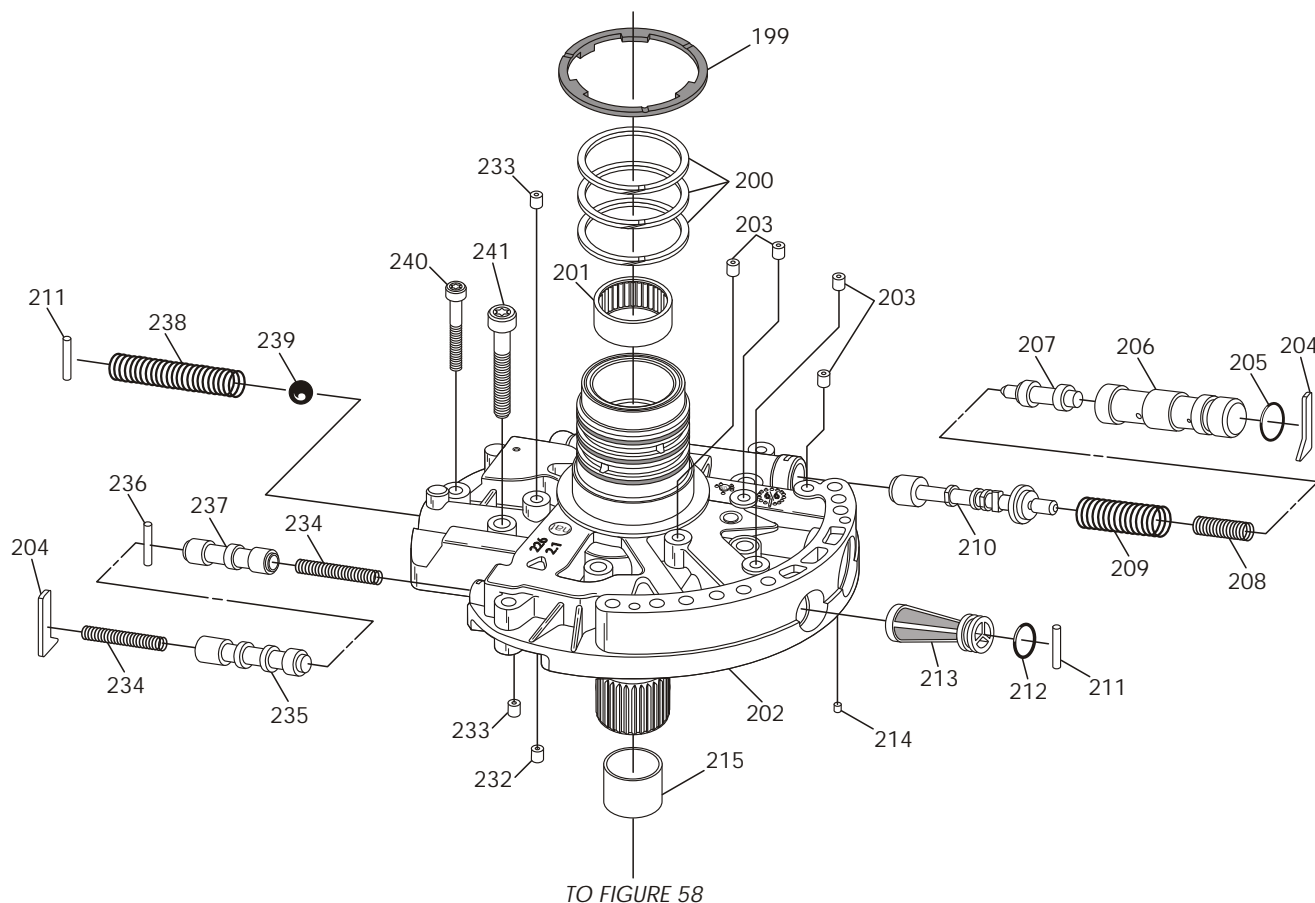

199 PUMP COVER TO REVERSE DRUM THRUST WASHER (SELECTIVE)

200 REVERSE CLUTCH SCARF-CUT SEAL RINGS

201 CAGED NEEDLE BEARING (PUMP COVER TO INPUT SHAFT)

202 OIL PUMP COVER ASSEMBLY

203 BALL CAPSULE ASSEMBLY (4)

204 VALVE BUSHING RETAINER

205 LINE PRESSURE BOOST VALVE BUSHING "O" RING SEAL

206 LINE PRESSURE BOOST VALVE BUSHING

207 LINE PRESSURE BOOST VALVE

208 LINE PRESSURE BOOST VALVE SPRING

209 PRESSURE REGULATOR VALVE SPRING

210 PRESSURE REGULATOR VALVE

211 OIL PUMP COVER RETAINING PIN

212 OIL PUMP COVER SCREEN ASSEMBLY "O" RING SEAL

213 OIL PUMP COVER SCREEN ASSEMBLY

214 BRASS ORIFICE CUP PLUG

215 STATOR SHAFT TO INPUT SHAFT BUSHING

216 OIL PUMP SLIDE (SELECTIVE)

217 OIL PUMP SLIDE SEAL SUPPORT

218 OIL PUMP SLIDE "TEFLON" SEAL

219 OIL PUMP SLIDE RETURN SPRING

220 OIL PUMP SLIDE "TEFLON" SEAL RING

221 OIL PUMP VANE RINGS (2)

222 OIL PUMP VANES (13)

223 OIL PUMP ROTOR (SELECTIVE)

224 OIL PUMP ROTOR GUIDE

226 TORQUE CONVERTER HUB BUSHING

227 TORQUE CONVERTER HOUSING

228 TORQUE CONVERTER HUB METAL CLAD SEAL

229 TORQUE CONVERTER METAL CLAD SEAL RETAINING BOLTS (2)

230 TORQUE CONVERTER HOUSING TO MAIN CASE "O" RING SEAL

231 OIL PUMP SLIDE PIVOT PIN AND SPRING ASSEMBLY

232 ORIFICED SLEEVE ASSEMBLY

233 ORIFICED CUP PLUG (2)

234 TCC CONTROL/ENABLE VALVE SPRINGS (2 SAME)

235 TCC CONTROL VALVE

236 TCC ENABLE VALVE RETAINING PIN

237 TCC ENABLE VALVE

238 LINE PRESSURE RELIEF BALL SPRING

239 LINE PRESSURE RELIEF BALL

240 OIL PUMP COVER RETAINING BOLT 6 X 1.25 X 40 (6)

241 OIL PUMP COVER RETAINING BOLT 8 X 1.25 X 40 (5)

242 OIL PUMP SLIDE SEAL BACK-UP "O" RING

Copyright © 2002 ATSG

Figure 57



Technical Service Information

OIL PUMP AND BELL HOUSING ASSEMBLY EXPLODED VIEW

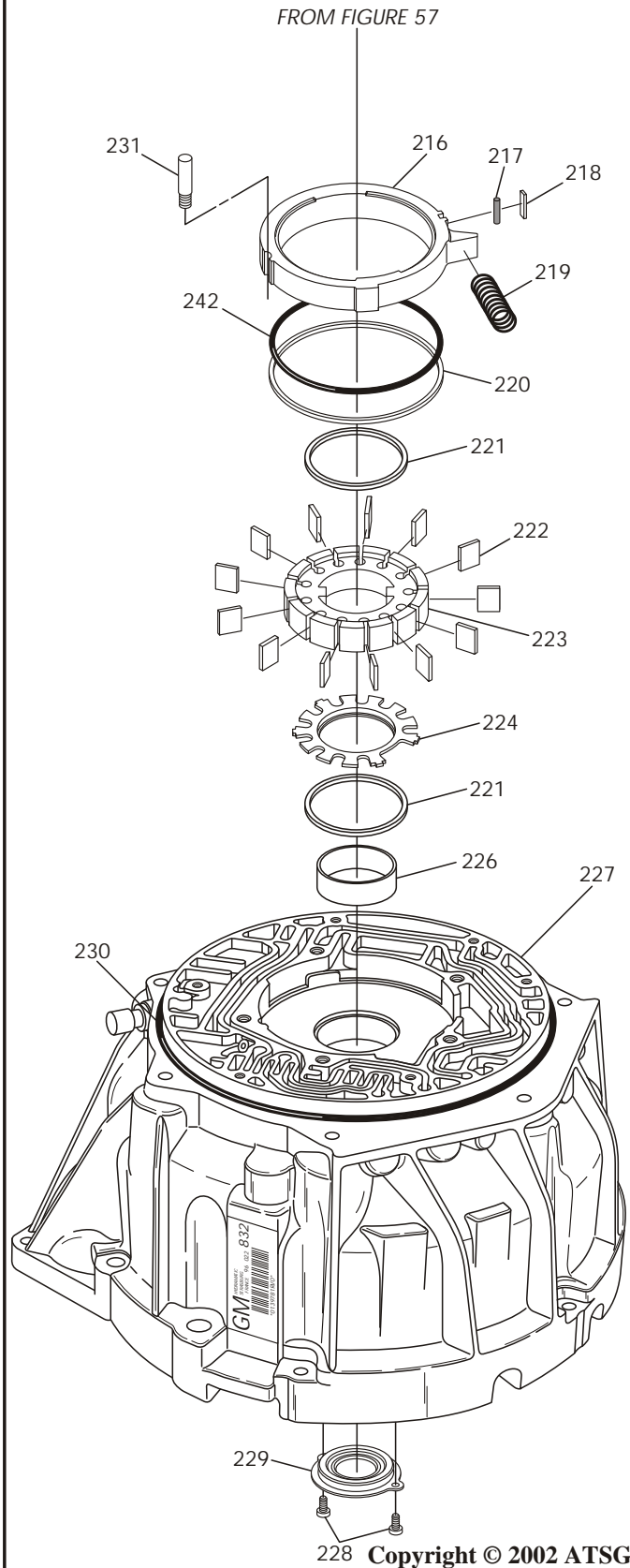

Figure 58

COMPONENT REBUILD SECTION OIL PUMP ASSEMBLY

1. Use Figure 57 and 58 as a guide to disassemble the converter housing and oil pump assembly.
2. Clean all converter housing and oil pump parts thoroughly and dry with compressed air.
3. Inspect all converter housing and pump parts thoroughly and replace as necessary.
4. Lubricate all valves and sleeves with clean transmission fluid and install the valve line-ups exactly as shown in Figure 57.
5. Install a new pump screen and "O" ring seal in pump cover as shown in Figure 57.
6. Install the selective thrust washer on the pump cover and retain with Trans-Jel®.
7. Ensure that orifice cup plugs and ball capsules are in place and functional.
8. The caged needle bearing can be serviced as necessary with the proper puller and driver.
9. The bushing is not serviced and if necessary will require a complete pump cover.
10. Set the completed pump cover aside for final oil pump and converter housing assembly, as shown in Figure 59.

Continued on Page 46

COMPLETED PUMP COVER ASSEMBLY

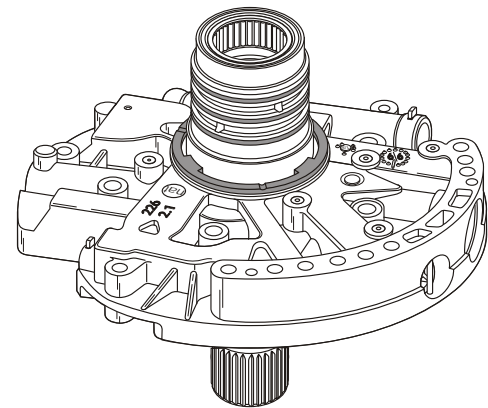

Copyright © 2002 ATSG

Figure 59



Technical Service Information

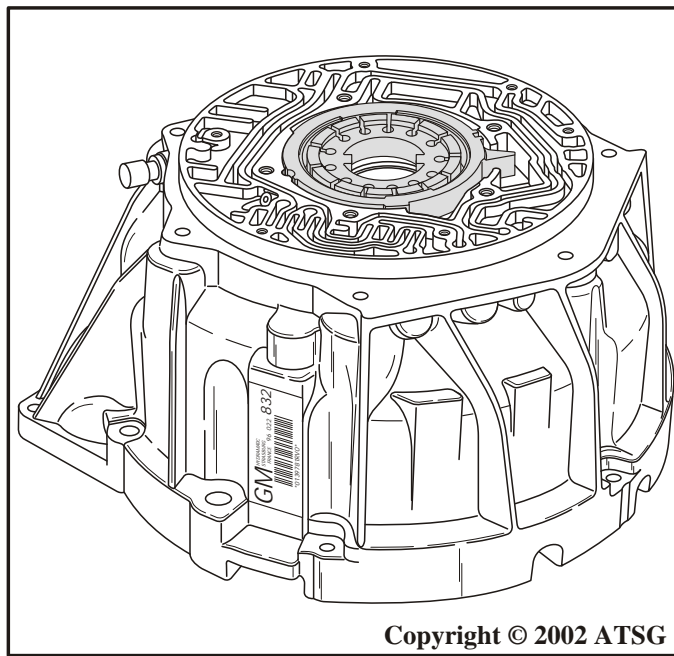

Copyright © 2002 ATSG

Figure 60

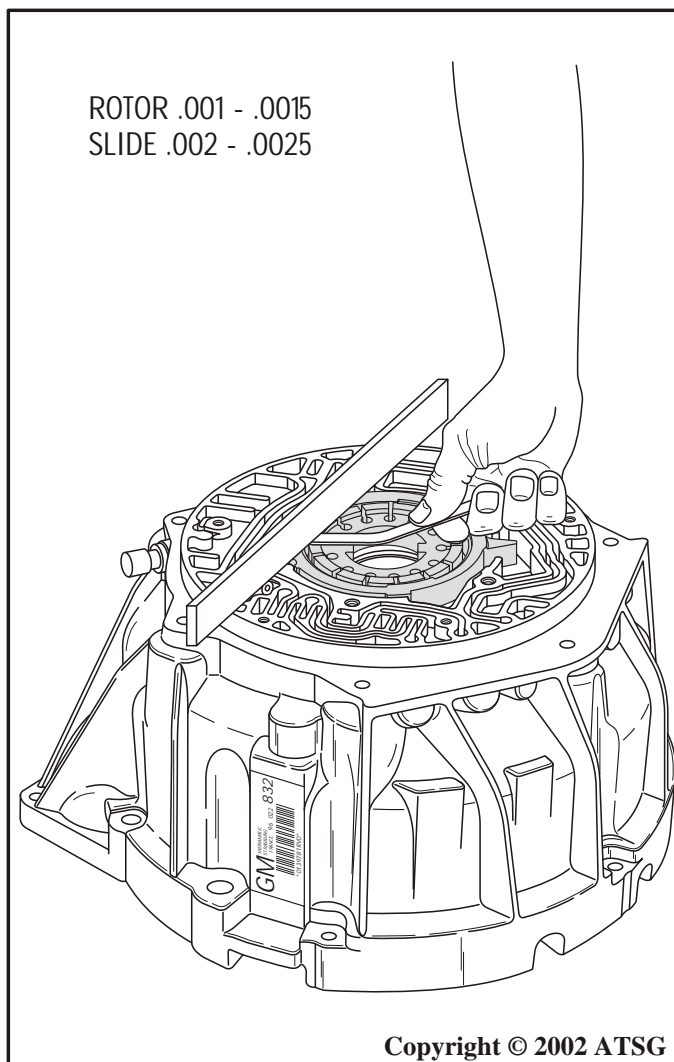

Copyright © 2002 ATSG

Figure 61

COMPONENT REBUILD (CONT'D) OIL PUMP ASSEMBLY (CONT'D)

11. Place the converter housing on a flat surface with the worm track side facing up and install the current slide and rotor (See Figure 60).
12. Ensure that the slide seals are left out.
13. Lay a straight edge across the surface over the slide and rotor, as shown in Figure 61.
14. Measure the clearance between the slide and the straight edge, as shown in Figure 61. The clearance should be .002"-.0025" with no seals in the slide.
15. Measure the clearance between the rotor and the straight edge, as shown in Figure 61. The clearance should be .001"-.0015".
Note: These measurements may also be done with a depth micrometer.
16. If replacements are needed, use the chart in Figure 63 to make your selections based on the clearance recorded and the thickness of the current slide and rotor.
17. Install new bushing as necessary in converter housing, as shown in Figure 62, using proper size bushing driver.
18. Install the pump slide pivot pin and spring, as shown in Figure 64.

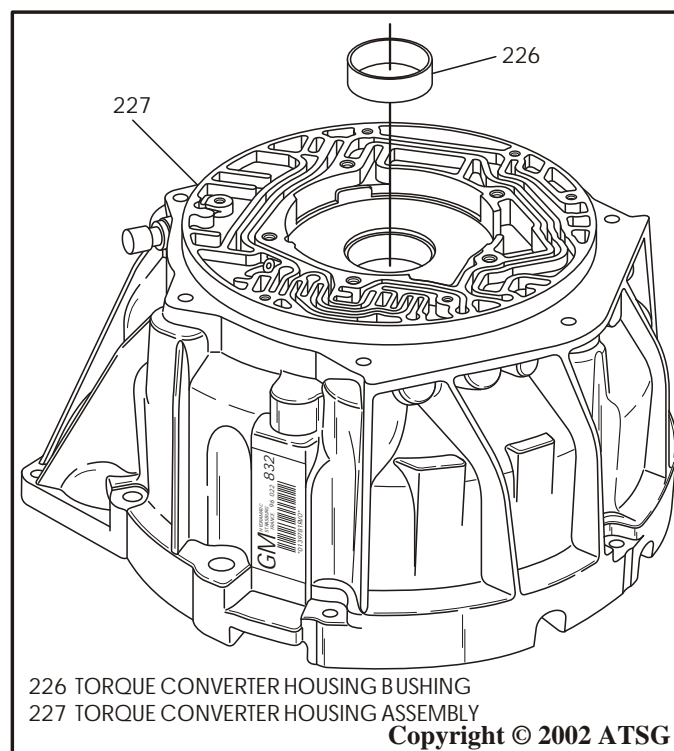

226 TORQUE CONVERTER HOUSING BUSHING
227 TORQUE CONVERTER HOUSING ASSEMBLY

Copyright © 2002 ATSG

Figure 62



Technical Service Information

19. Install oil pump slide back-up "O" ring (242) and pump slide "Teflon" seal ring (220) into groove in slide, as shown in Figure 64.
20. Install oil pump slide seal support (217) into slide, as shown in Figure 64, and retain with a small amount of Trans-Jel®.
21. Install the oil pump slide into the pump pocket as shown in Figure 64, with the "Teflon" seal (220) facing down.
22. Install the oil pump slide "Teflon" seal (218) by pulling the slide towards the pump pivot pin and sliding the seal down between slide seal support (217) and converter housing, as shown in Figure 64.
23. Install the oil pump slide spring, as shown in Figure 64, using a screwdriver or installation tool.

Continued on Page 48

OIL PUMP ROTOR SELECTION CHART

THICKNESS (mm)	THICKNESS (In)
17.948 - 17.961	0.7065 - 0.7071
17.962 - 17.974	0.7071 - 0.7076
17.975 - 17.987	0.7076 - 0.7081
17.988 - 18.000	0.7081 - 0.7086
18.001 - 18.013	0.7086 - 0.7091

OIL PUMP SLIDE SELECTION CHART

THICKNESS (mm)	THICKNESS (In)
17.948 - 17.961	0.7065 - 0.7071
17.962 - 17.974	0.7071 - 0.7076
17.975 - 17.987	0.7076 - 0.7081
17.988 - 18.000	0.7081 - 0.7086
18.001 - 18.013	0.7086 - 0.7091

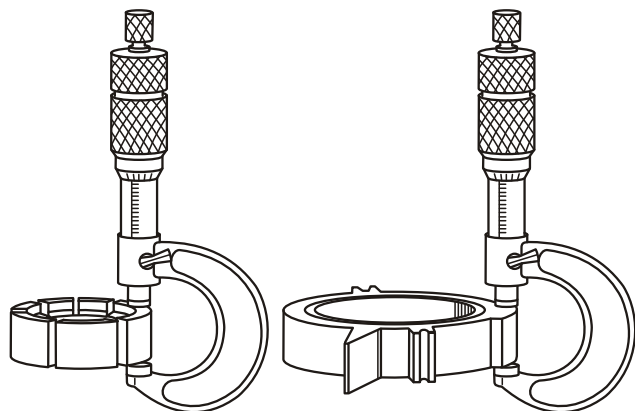

Copyright © 2002 ATSG

Figure 63

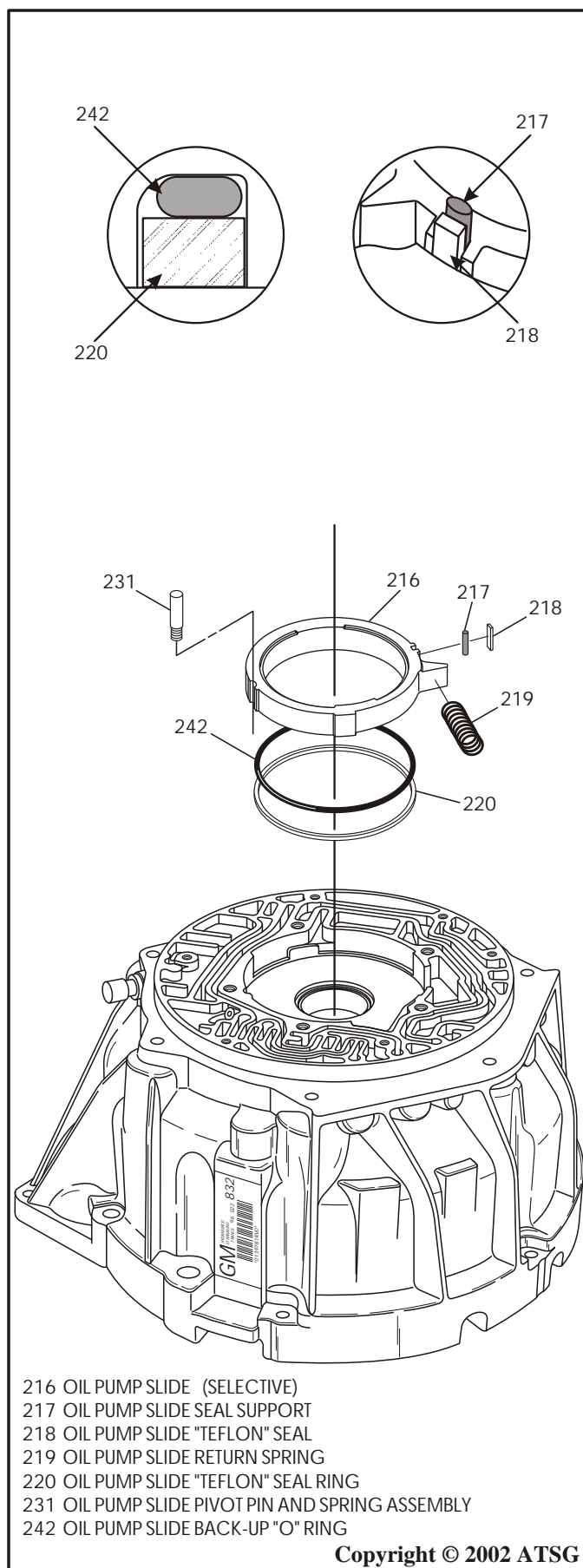

- 216 OIL PUMP SLIDE (SELECTIVE)
- 217 OIL PUMP SLIDE SEAL SUPPORT
- 218 OIL PUMP SLIDE "TEFLON" SEAL
- 219 OIL PUMP SLIDE RETURN SPRING
- 220 OIL PUMP SLIDE "TEFLON" SEAL RING
- 231 OIL PUMP SLIDE PIVOT PIN AND SPRING ASSEMBLY
- 242 OIL PUMP SLIDE BACK-UP "O" RING

Copyright © 2002 ATSG

Figure 64



Technical Service Information

COMPONENT REBUILD (CONT'D) OIL PUMP ASSEMBLY (CONT'D)

24. Install the oil pump rotor guide into the rotor in the direction shown in Figure 65, and retain with a small amount of Trans-Jel®.
25. Install one of the oil pump vane rings into the pump pocket, as shown in Figure 66.
26. Install the previously assembled rotor guide and rotor assembly into the pump pocket and ensure that it is properly seated.
27. Install the 13 oil pump vanes into their slots in the rotor, as shown in Figure 66.
28. Install the other oil pump vane ring on top of the rotor and inside of the oil pump vanes. The finished assembly should look like illustration in Figure 66.
29. Install the pre-assembled oil pump cover onto the converter housing, as shown in Figure 67.
30. Install the proper pump cover to converter housing retaining bolts in their proper locations as shown in Figure 68, and hand tighten only.
31. Install the J-21368 pump alignment band and tighten, as shown in Figure 69.
32. Torque six pump cover retaining bolts (240) to 11 Nm (8 ft.lb.), as shown in Figure 69.
33. Torque five pump cover retaining bolts (241) to 22 Nm (16 ft.lb.), as shown in Figure 69.
34. Remove J-21368 pump alignment band.

Continued on Page 50

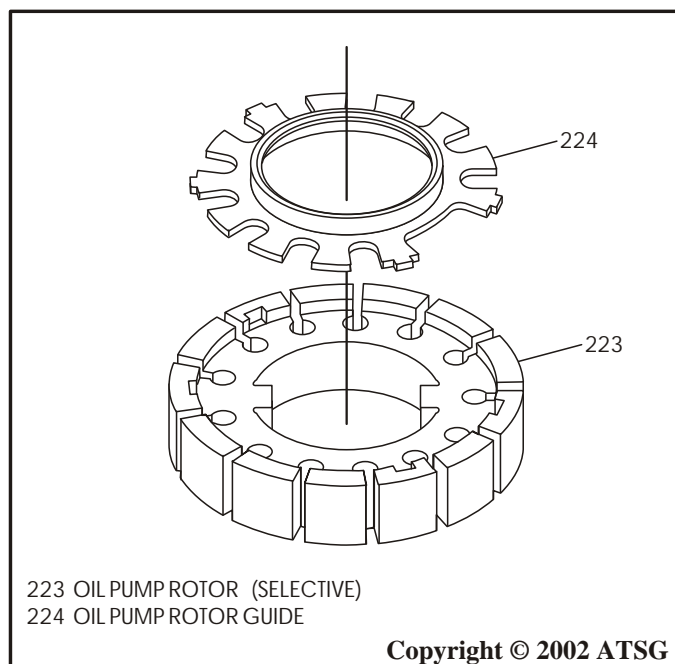

Figure 65

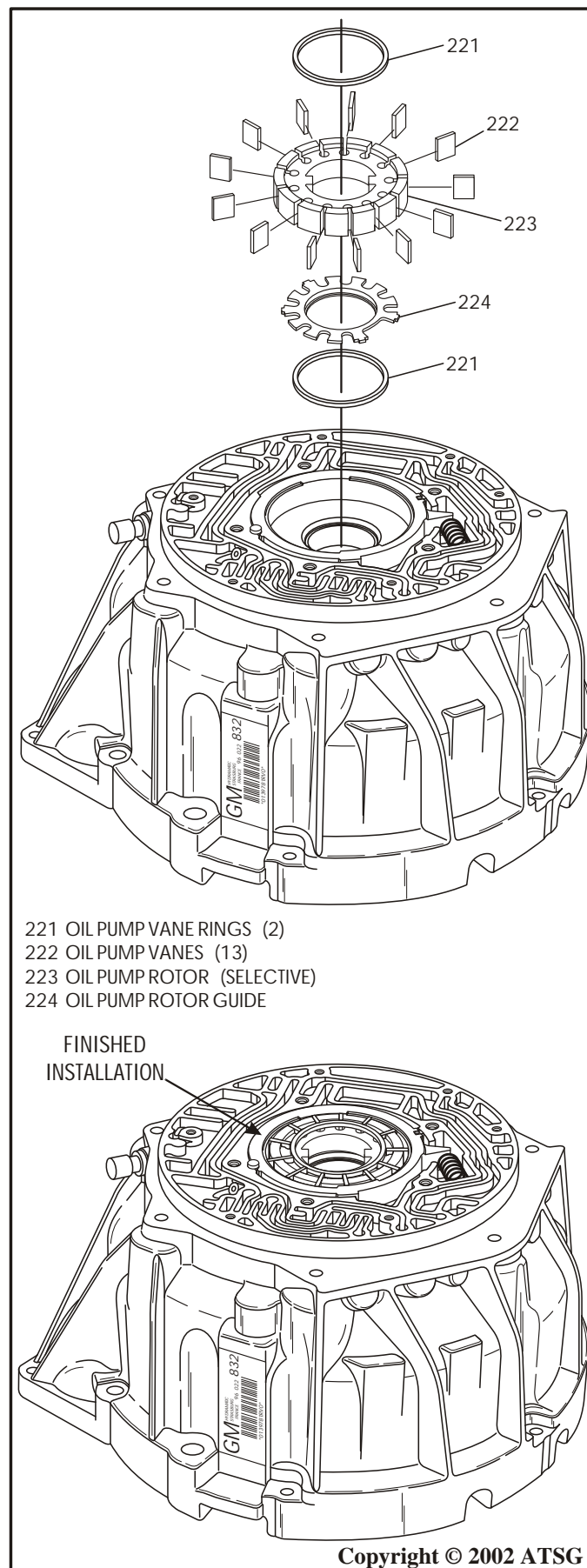

Figure 66



Technical Service Information

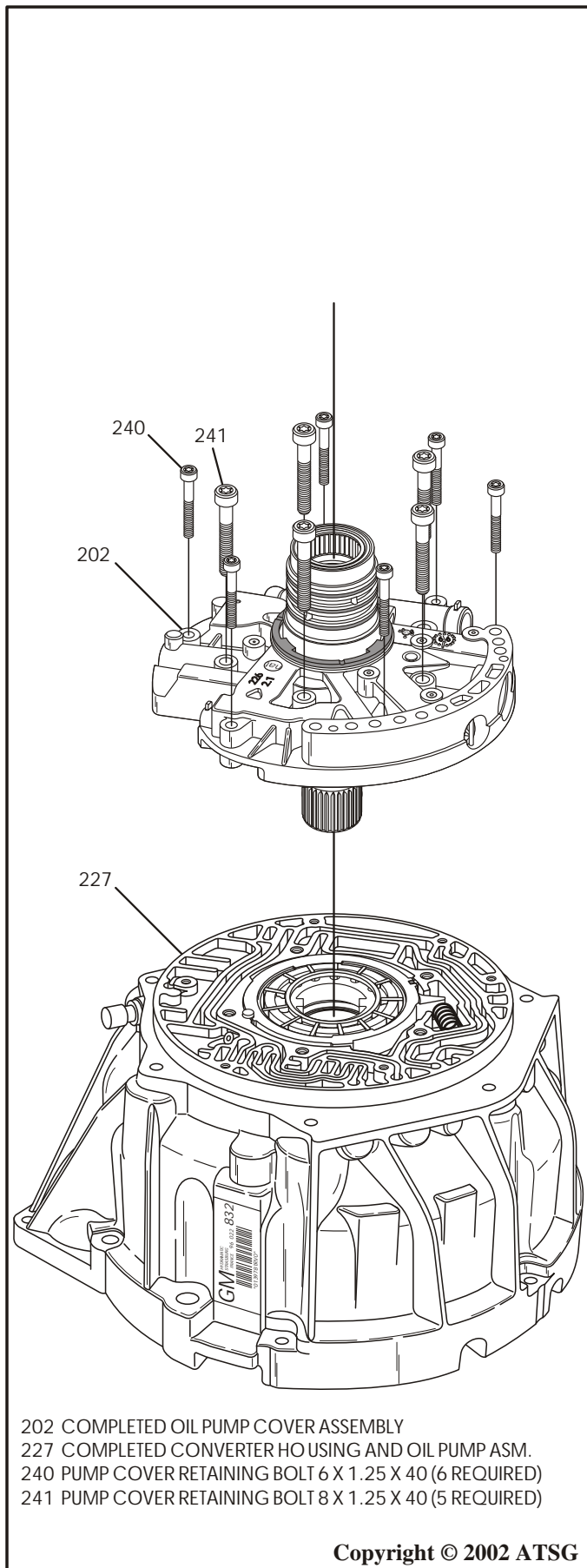

Figure 67

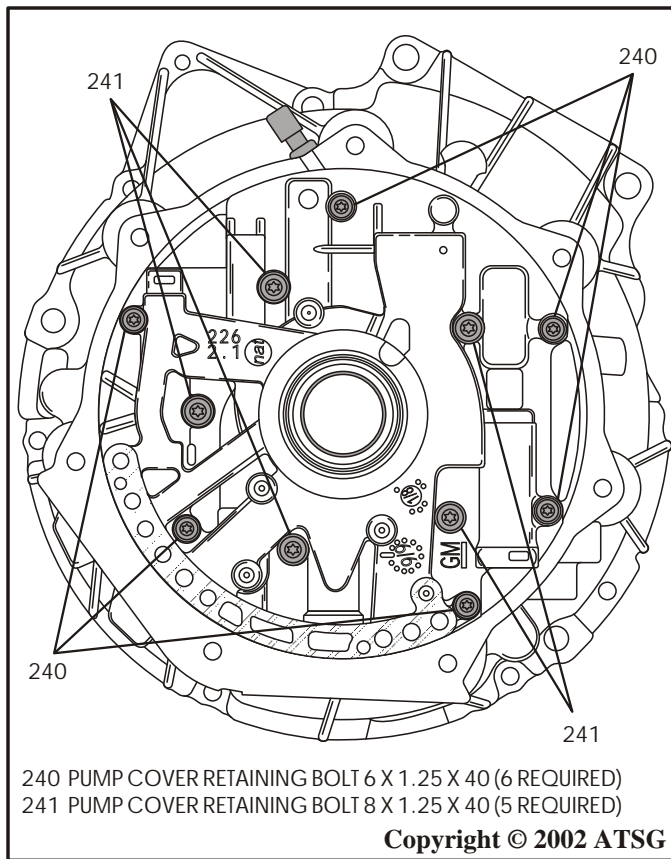

Figure 68

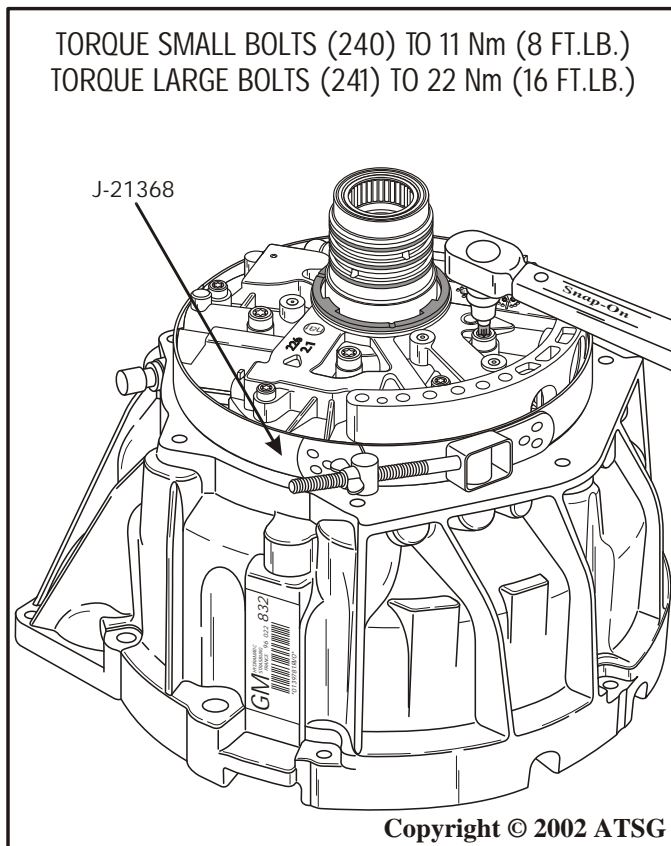

Figure 69



Technical Service Information

COMPONENT REBUILD (CONT'D)

OIL PUMP ASSEMBLY (CONT'D)

35. Install converter housing to case "O" ring seal, as shown in Figure 70, and ensure that it is fully seated.
36. Install new converter seal onto the installation tool J-44766, align the converter seal with the bolt holes, and then install the converter seal in the housing (See Figure 71).
37. Install the two seal retaining bolts and torque to 3.6 Nm (31 in.lb.), as shown in Figure 72.
38. Set the completed converter housing and pump assembly aside for the final assembly process.

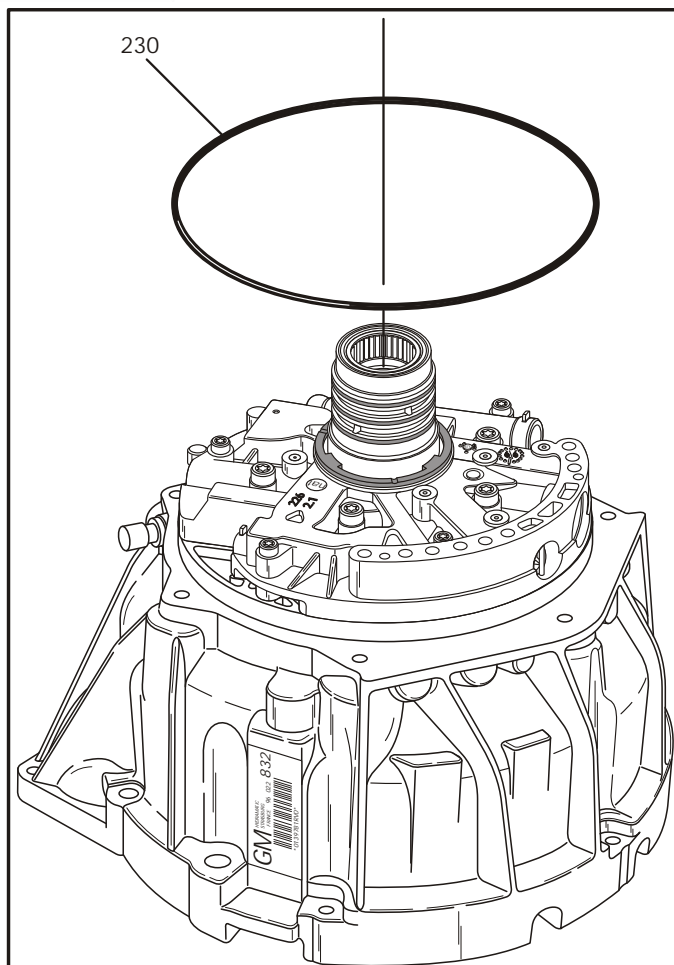

230 CONVERTER HOUSING TO MAIN CASE "O" RING SEAL

ENSURE THAT SEAL IS FULLY SEATED

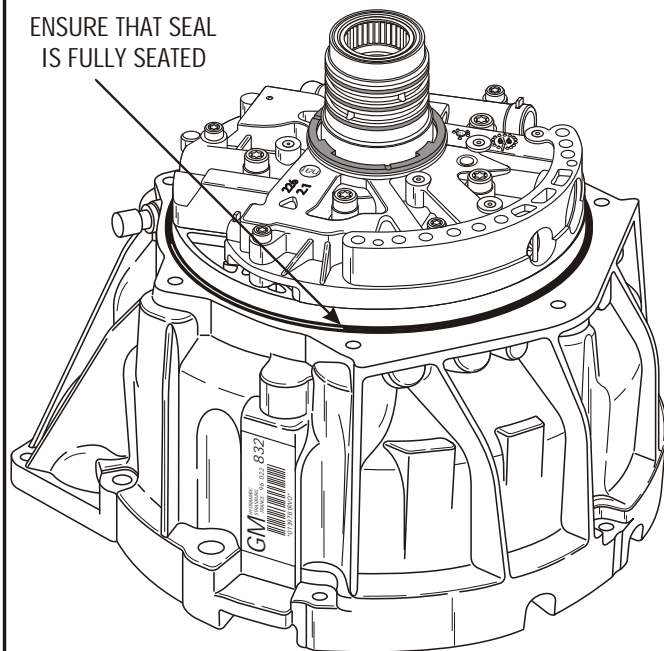

Copyright © 2002 ATSG

Figure 70

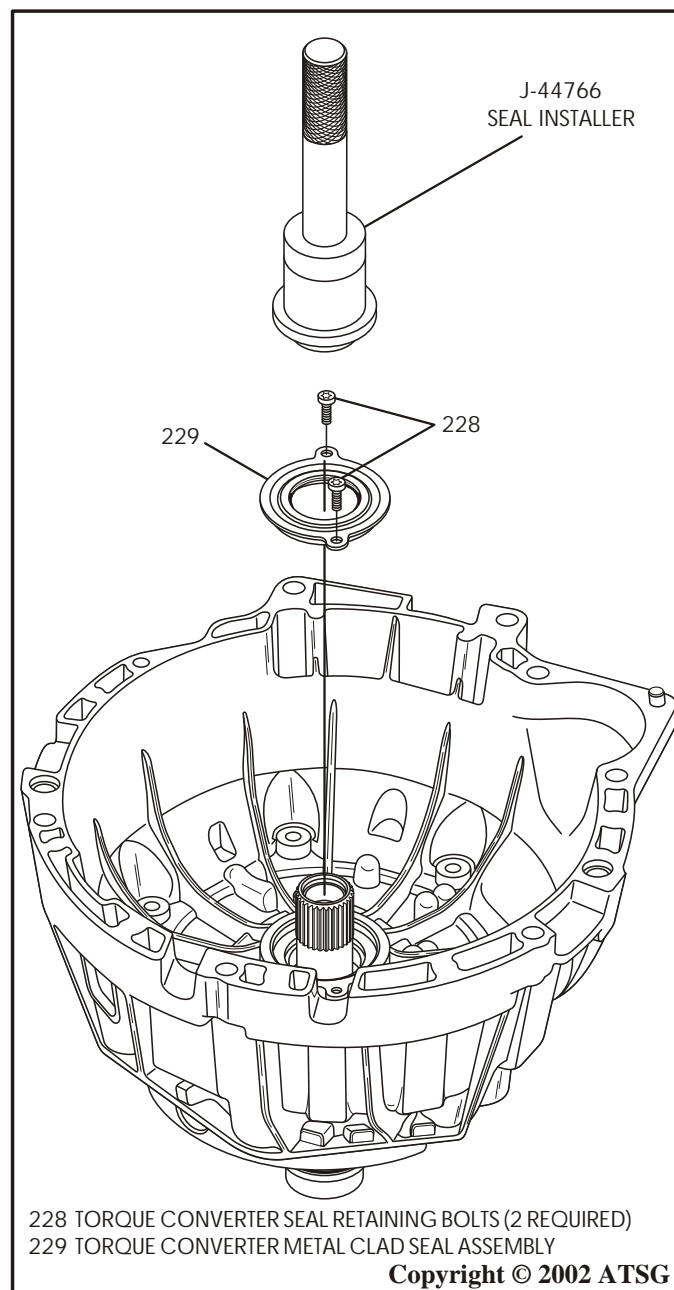

228 TORQUE CONVERTER SEAL RETAINING BOLTS (2 REQUIRED)
229 TORQUE CONVERTER METAL CLAD SEAL ASSEMBLY

Copyright © 2002 ATSG

Figure 71



Technical Service Information

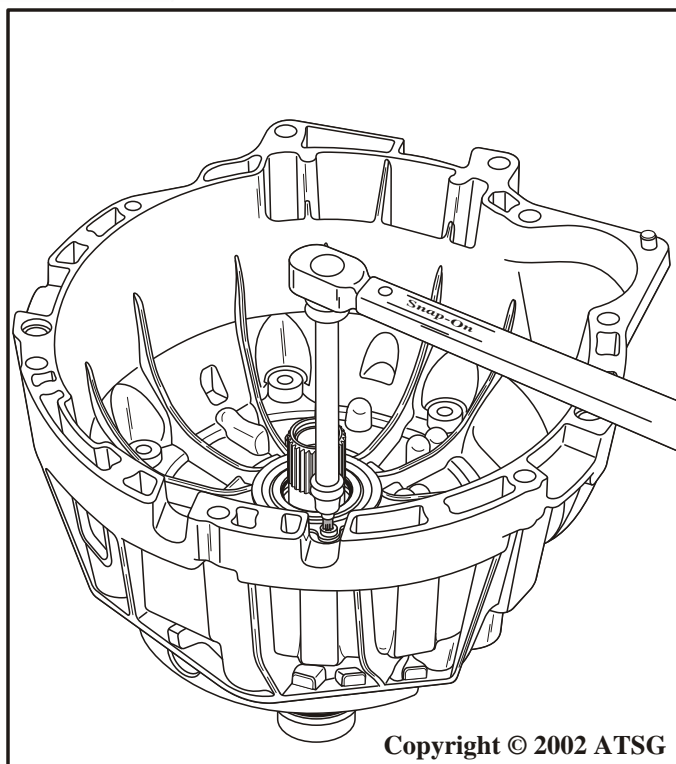

Copyright © 2002 ATSG

Figure 72

COMPONENT REBUILD

DIRECT AND REVERSE CLUTCH HOUSING

1. Using Figure 74 as a guide dis-assemble the direct and reverse clutch housing.
2. Clean thoroughly all direct and reverse clutch parts and dry with compressed air.
3. Inspect thoroughly all direct and reverse clutch parts for any wear and/or damage.
4. Inspect the direct clutch piston ball capsule for proper operation, as shown in Figure 73.
5. Inspect the reverse clutch housing ball capsule for proper operation, as shown in Figure 73.

Continued on Page 53

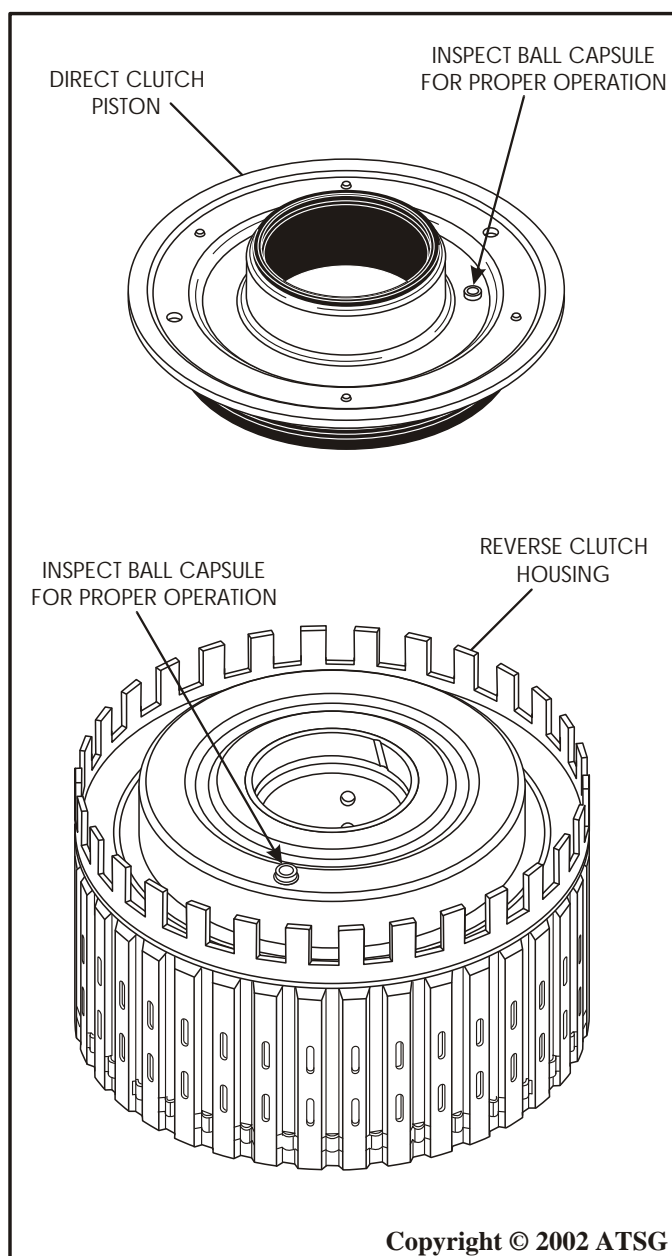

Copyright © 2002 ATSG

Figure 73



Technical Service Information

REVERSE AND DIRECT CLUTCH HOUSING ASSEMBLY

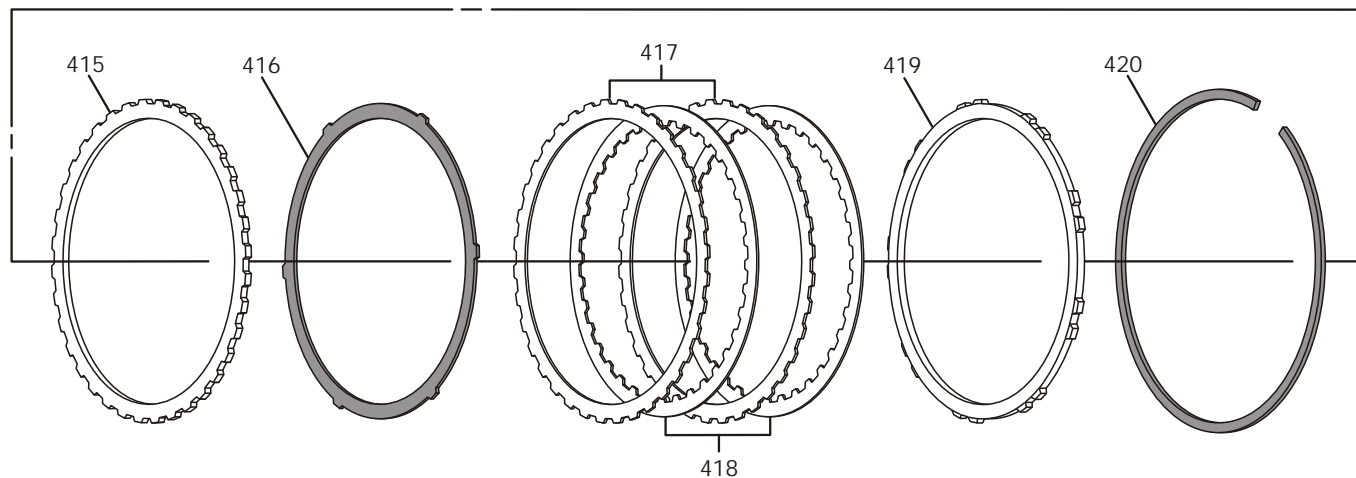
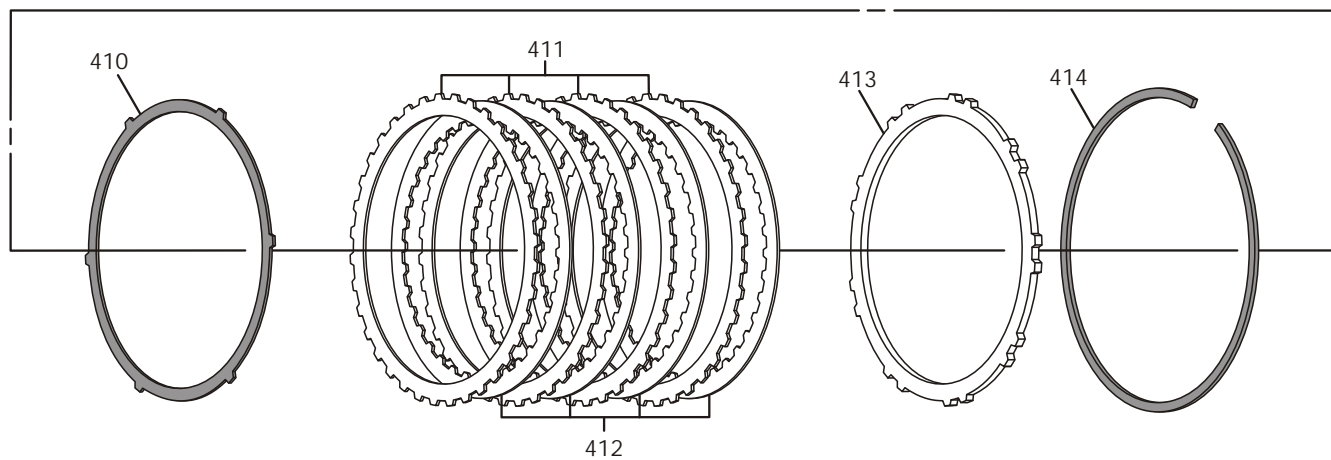
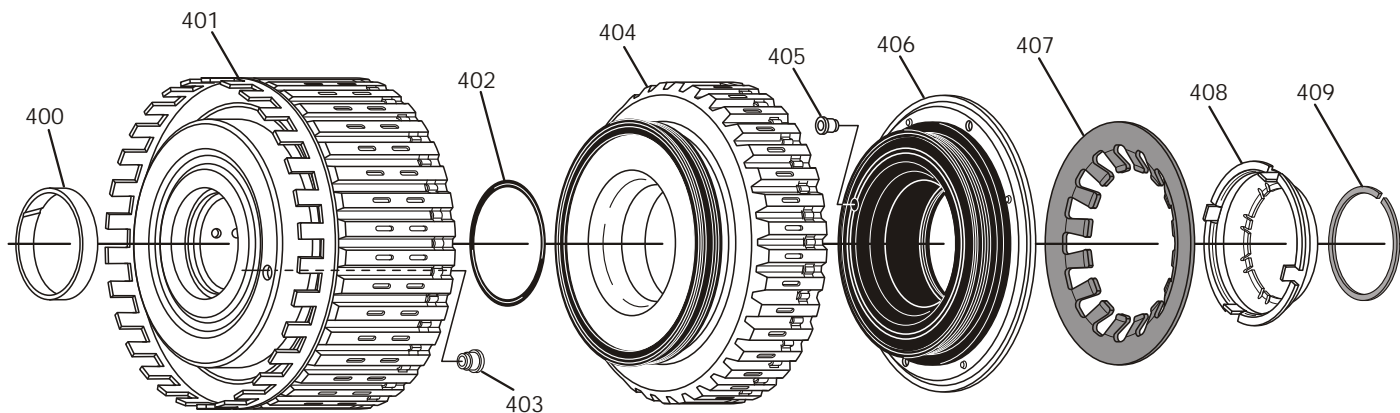

- 400 REVERSE CLUTCH HOUSING BUSHING
- 401 REVERSE CLUTCH HOUSING ASSEMBLY
- 402 REVERSE CLUTCH HOUSING INNER "O" RING SEAL
- 403 REVERSE CLUTCH HOUSING BALL CAPSULE ASSEMBLY
- 404 REVERSE CLUTCH PISTON/DIRECT CLUTCH HOUSING
- 405 DIRECT CLUTCH PISTON BALL CAPSULE ASSEMBLY
- 406 DIRECT CLUTCH PISTON ASSEMBLY
- 407 DIRECT AND REVERSE CLUTCH BELLVILLE RETURN SPRING
- 408 DIRECT AND REVERSE CLUTCH RETURN SPRING RETAINER
- 409 RETURN SPRING RETAINER SNAP RING
- 410 DIRECT CLUTCH "WAVE" PLATE

- 411 DIRECT CLUTCH "OUTER SPLINE" SINGLE SIDED PLATES (4)
- 412 DIRECT CLUTCH "INNER SPLINE" SINGLE SIDED PLATES (4)
- 413 DIRECT CLUTCH BACKING PLATE
- 414 DIRECT CLUTCH BACKING PLATE SNAP RING (SELECTIVE)
- 415 REVERSE CLUTCH APPLY PLATE
- 416 REVERSE CLUTCH "WAVE" PLATE
- 417 REVERSE CLUTCH "OUTER SPLINE" SINGLE SIDED PLATES (2)
- 418 REVERSE CLUTCH "INNER SPLINE" SINGLE SIDED PLATES (2)
- 419 REVERSE CLUTCH BACKING PLATE
- 420 REVERSE CLUTCH BACKING PLATE SNAP RING (SELECTIVE)

Copyright © 2002 ATSG

Figure 74



Technical Service Information

COMPONENT REBUILD

DIRECT AND REVERSE CLUTCH HOUSING

6. Install new "O" ring seal into groove in the reverse clutch housing and lubricate with a small amount of Trans-Jel® (See Figure 75).
7. Lubricate the inside diameter of the direct clutch housing and install the direct clutch housing into the reverse clutch housing, as shown in Figure 75, by rotating into position.
8. The direct clutch housing (404) also serves as the reverse clutch piston and has a molded seal as shown in Figure 75.
9. Install J-45133 seal protector onto the reverse housing, as shown in Figure 76.
10. Lubricate the molded seals with a small amount of Trans-Jel® and install direct clutch piston by rotating into position (See Figure 76).

Continued on Page 54

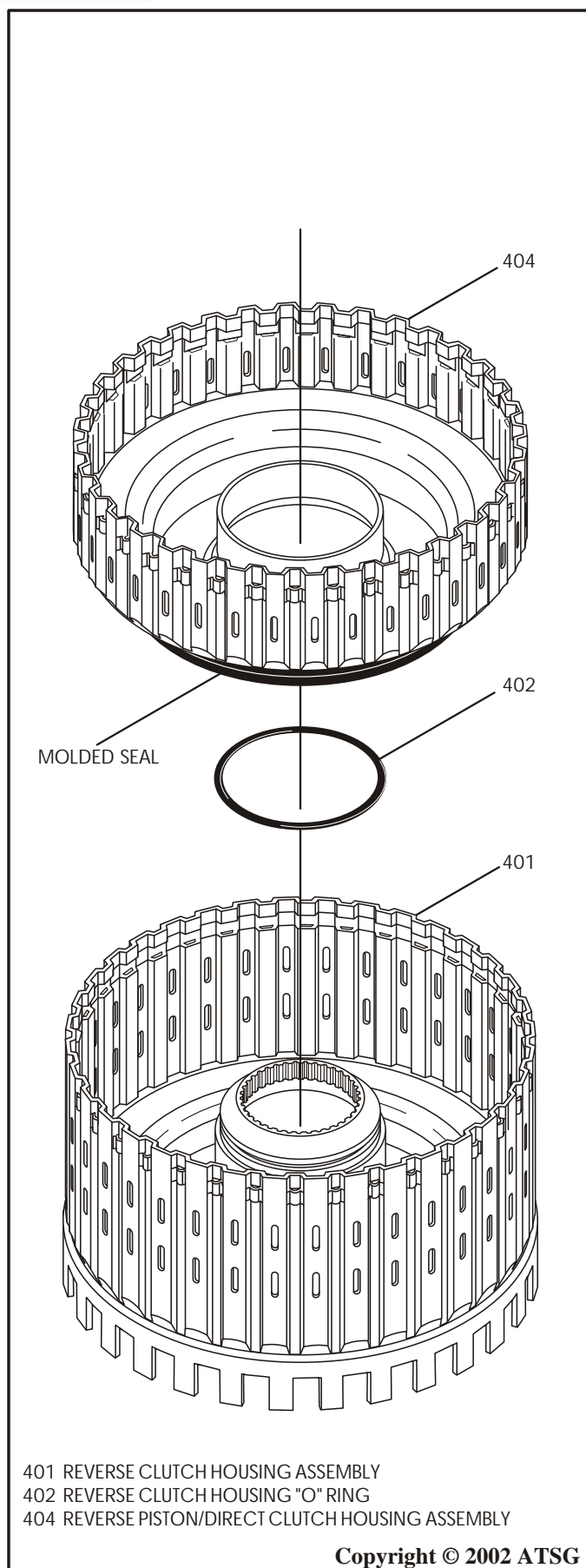

Figure 75

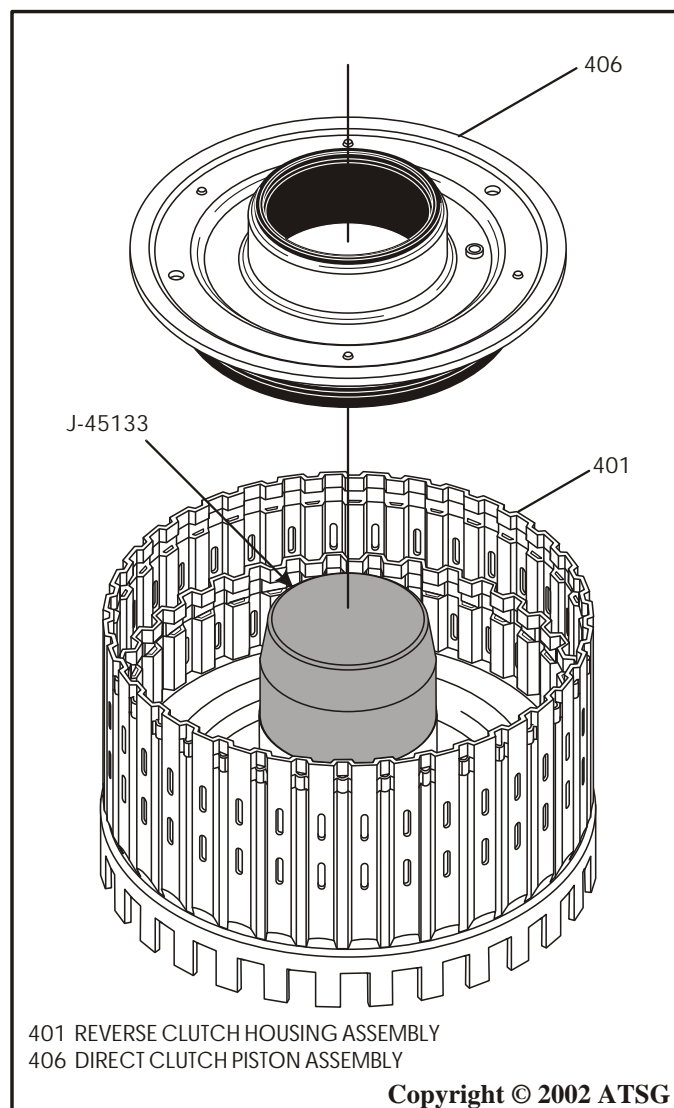

Figure 76



Technical Service Information

COMPONENT REBUILD

DIRECT AND REVERSE CLUTCH HOUSING (CONT'D)

11. Install the direct/reverse bellville return spring on top of the direct clutch piston, as shown in Figure 77.
 12. Install the bellville return spring retainer, as shown in Figure 77.
 13. Using a universal spring compressor or a foot press, compress the bellville spring and install the snap ring (See Figures 77 and 78).
- Note: GM recommends a "New" snap ring for this location.**
14. Install the direct clutch "Wave" plate, as shown in Figure 78.

Continued on Page 55

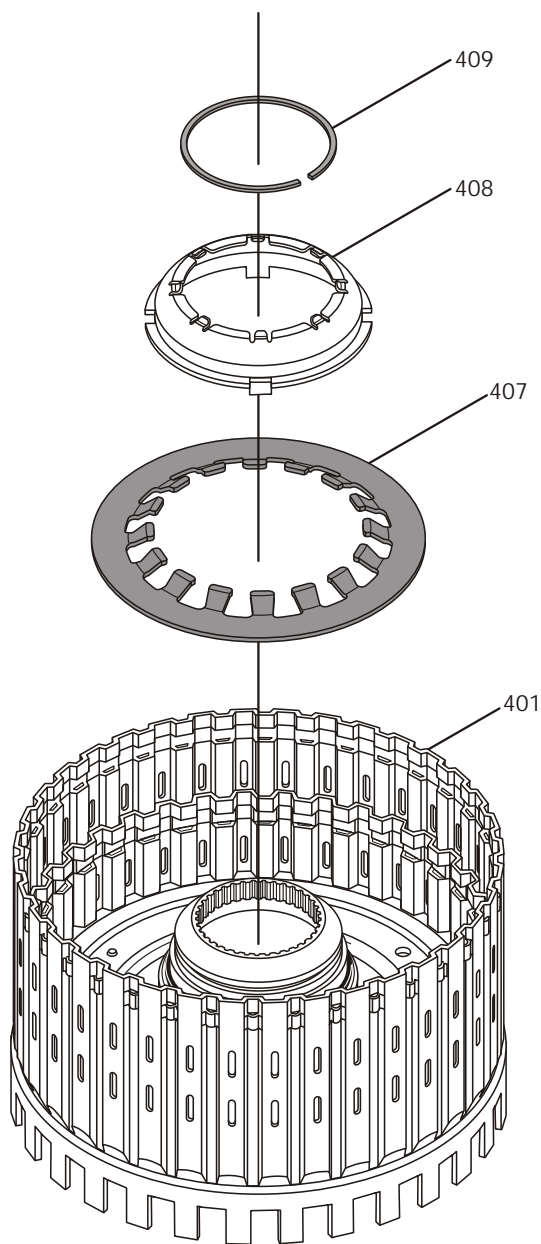

401 REVERSE CLUTCH HOUSING ASSEMBLY
 407 DIRECT/REVERSE BELLVILLE RETURN SPRING ASSEMBLY
 408 DIRECT/REVERSE CLUTCH SPRING RETAINER
 409 RETURN SPRING RETAINER SNAP RING

Copyright © 2002 ATSG

Figure 77

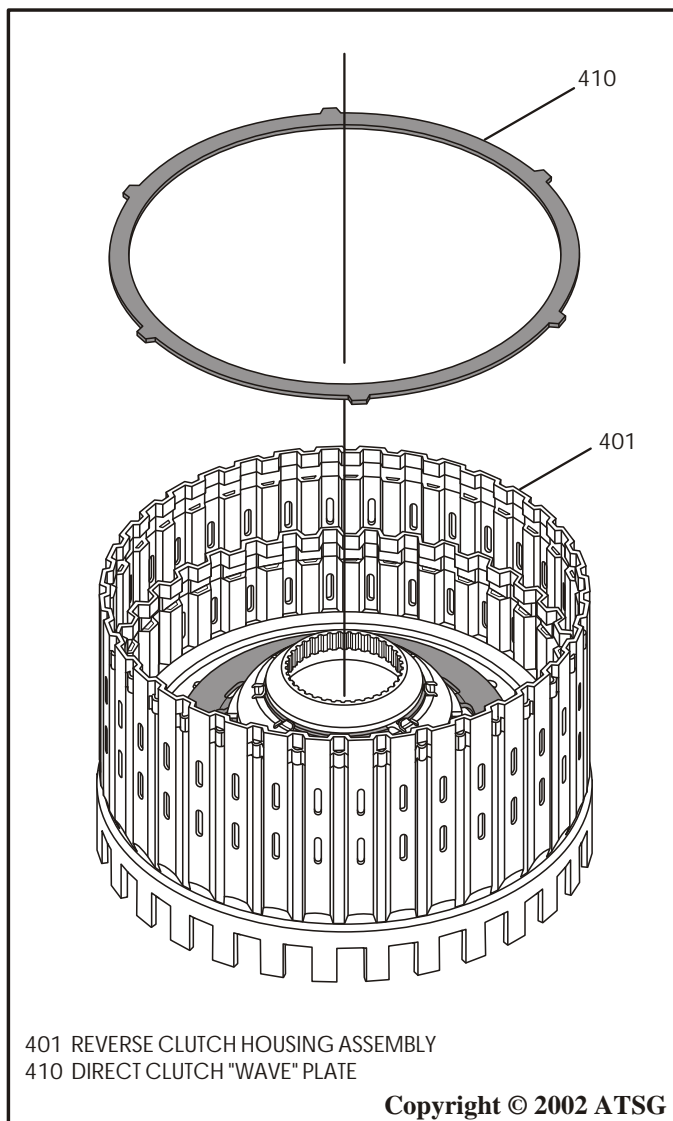

401 REVERSE CLUTCH HOUSING ASSEMBLY
 410 DIRECT CLUTCH "WAVE" PLATE

Copyright © 2002 ATSG

Figure 78



Technical Service Information

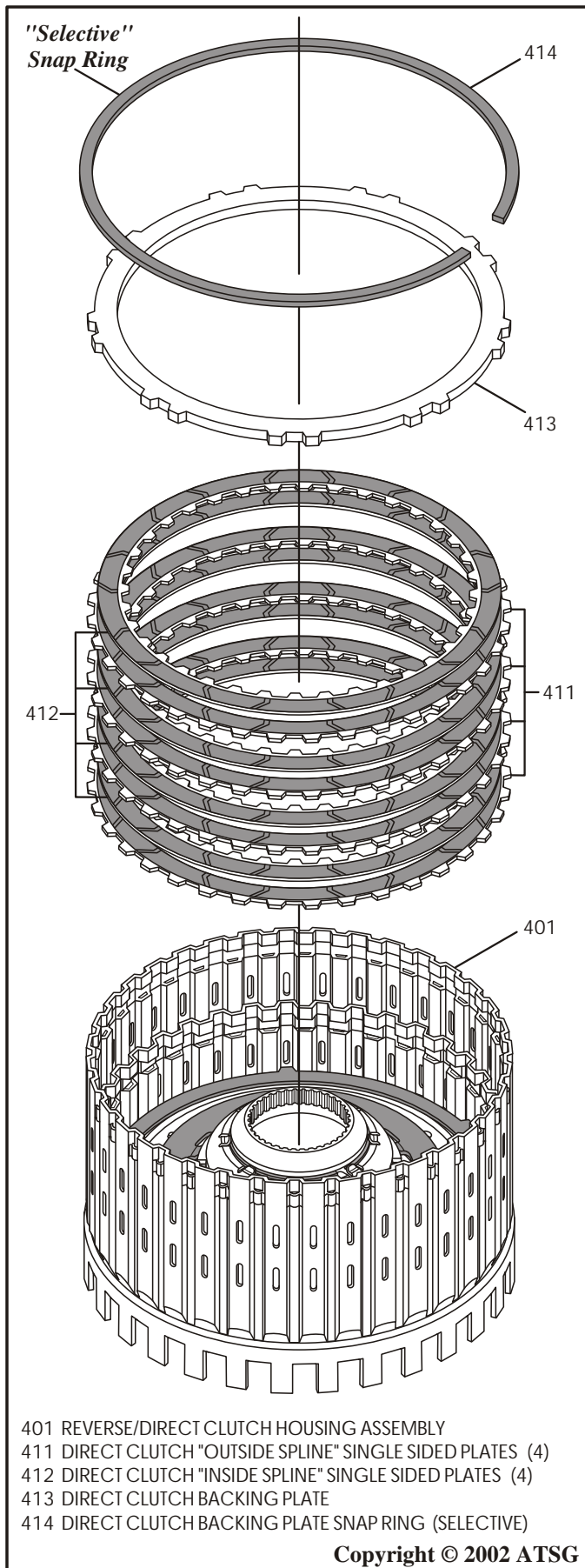

Figure 79

15. Install the direct clutch "single sided" plates beginning with an outside spline plate first and alternating with inside spline plates until you have installed 4 of each, as shown in Figure 79.
Note: Lined side must be installed facing up as shown. Clutch plate amounts may vary by model.
16. Install the direct clutch backing plate on top of the last inside spline plate (See Figure 79).
17. Install the "Selective" backing plate snap ring, as shown in Figure 79, and ensure that the snap ring is fully seated against the top of the snap ring groove in housing.
18. Install dial indicator on top of the direct clutch backing plate, as shown in Figure 80, and zero the dial indicator.
19. Direct clutch clearance should be: 1.06 mm (.042") to 1.86 mm (.073"). Change the "Selective" backing plate snap ring as necessary to achieve proper clutch clearance.

Continued on Page 56

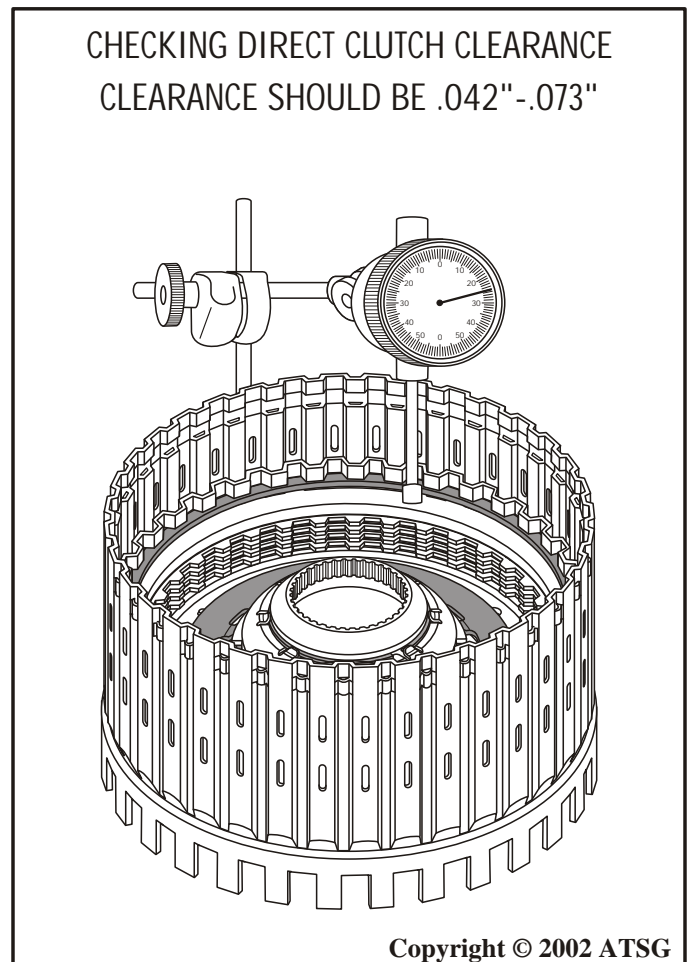

Figure 80



Technical Service Information

COMPONENT REBUILD

DIRECT AND REVERSE CLUTCH HOUSING (CONT'D)

20. Install the reverse clutch apply plate with the lip facing up, as shown in Figure 81.
 21. Install the reverse clutch "Wave" plate on top of the apply plate, as shown in Figure 81.
 22. Install the reverse clutch "single sided" plates beginning with an outside spline plate first and alternating with inside plates until you have installed 2 of each, as shown in Figure 82.
- Note: Lined side must be installed facing up as shown in Figure 82. Clutch plate amounts may vary by model.**
23. Install the reverse clutch backing plate on top of the last inside spline plate, as shown in Figure 82.
 24. Install the "Selective" backing plate snap ring as shown in Figure 82, and ensure that the snap ring is fully seated against the top of the snap ring groove in reverse housing.
 25. Install dial indicator on top of reverse clutch backing plate, as shown in Figure 83, and zero the dial indicator.
 26. Reverse clutch clearance should be: 0.98 mm (.039") to 1.43 mm (.056"). Change the "Selective" backing plate snap ring as necessary to achieve proper clutch clearance.
 27. Set the completed Direct/Reverse Clutch Housing aside for the final assembly process.

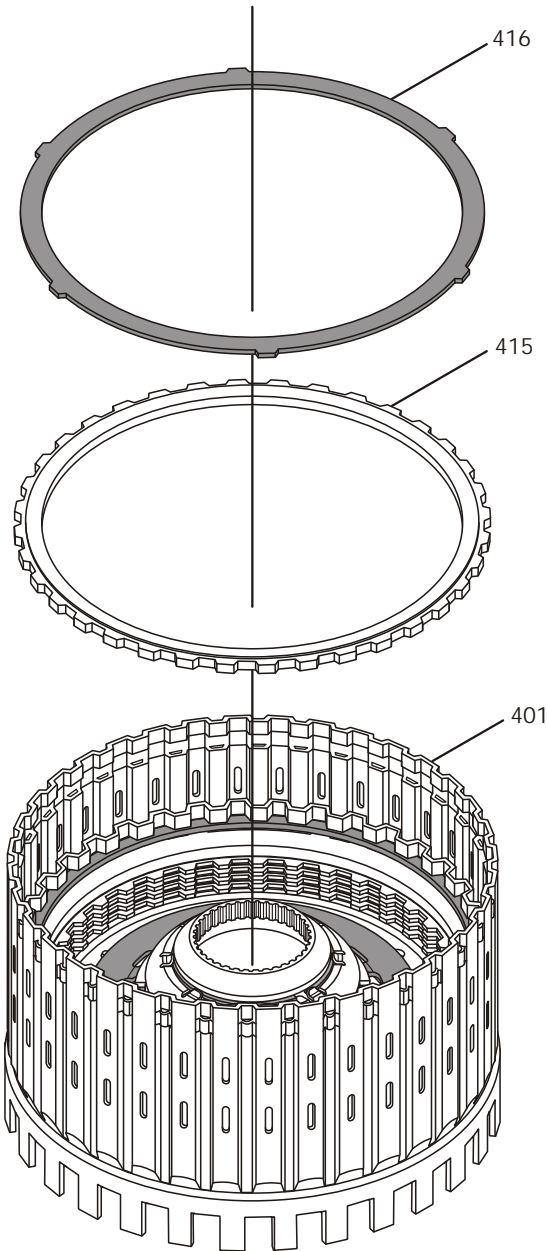

401 REVERSE/DIRECT CLUTCH HOUSING ASSEMBLY
 415 REVERSE CLUTCH APPLY PLATE (LIP FACING UP)
 416 REVERSE CLUTCH "WAVE" PLATE

Copyright © 2002 ATSG

**Component Rebuild Section
 Continued on Page 59**

Figure 81



Technical Service Information

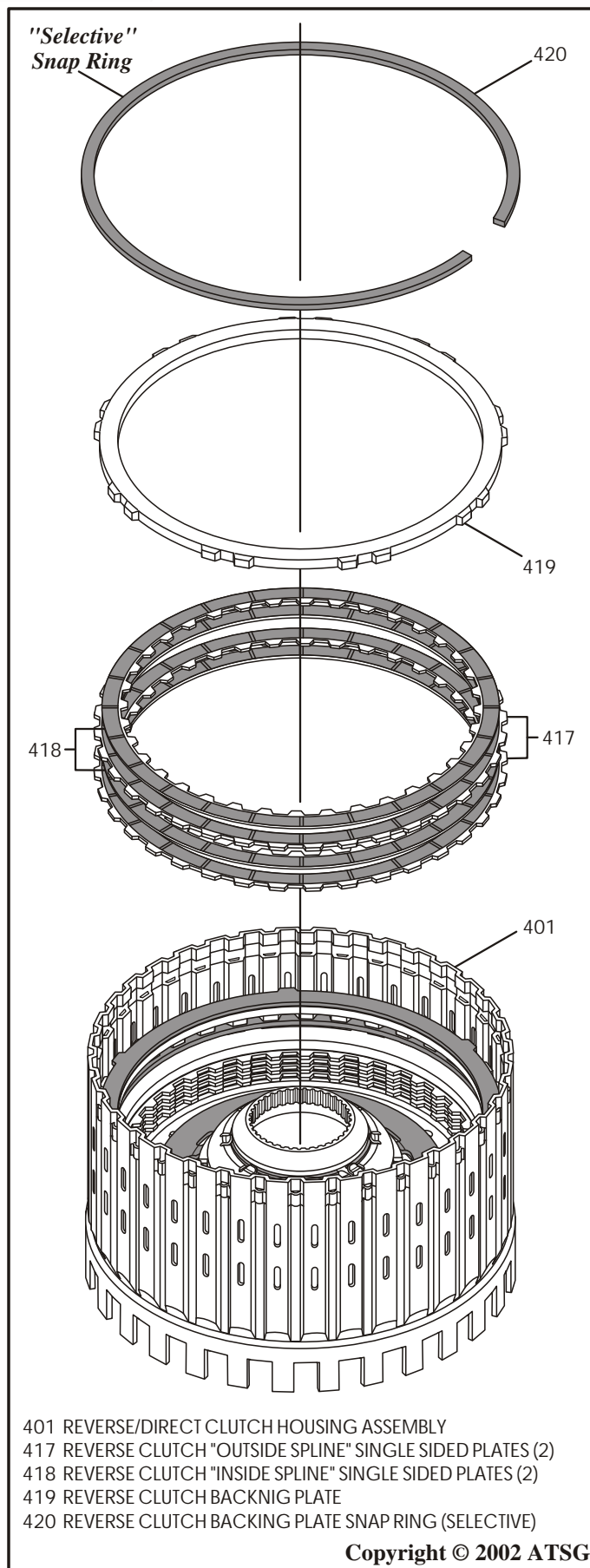

Figure 82

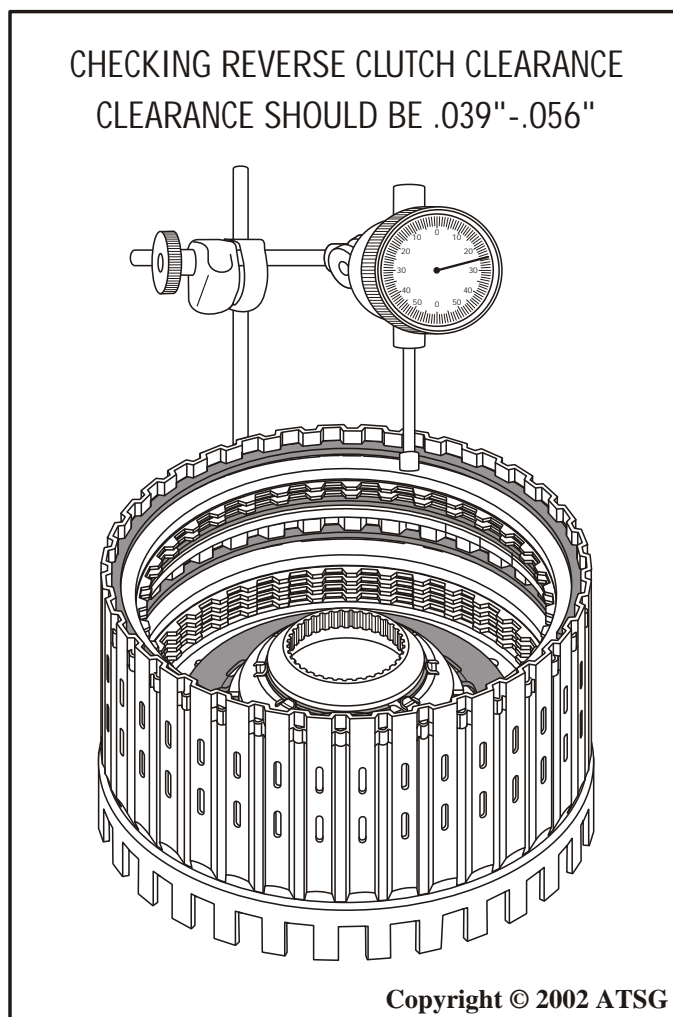
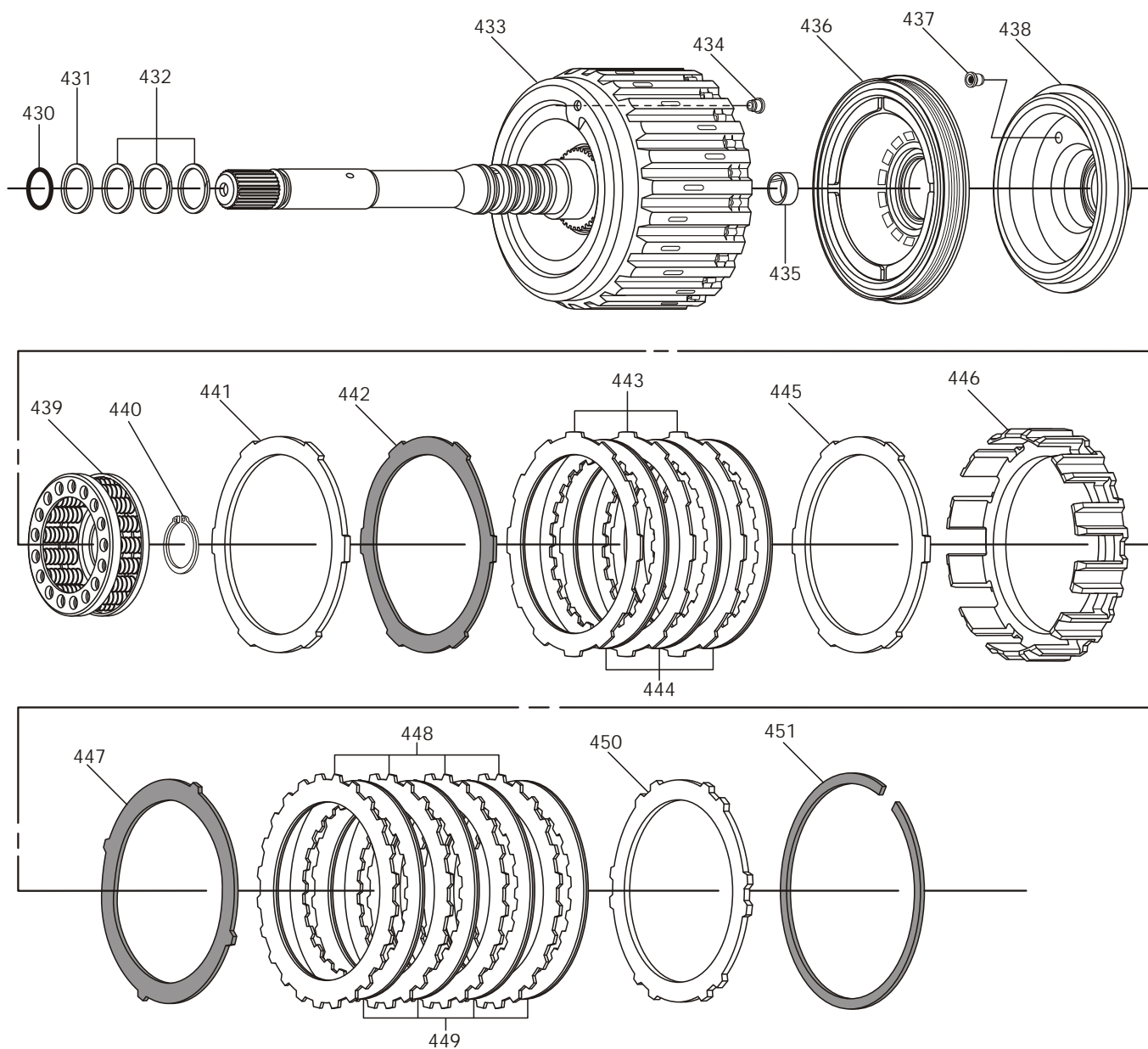

Figure 83



Technical Service Information

FORWARD AND COAST CLUTCH HOUSING ASSEMBLY



- 430 INPUT SHAFT "O" RING SEAL
- 431 INPUT SHAFT "SOLID" TEFLON SEAL RING (1 REQUIRED)
- 432 INPUT SHAFT "SCARF-CUT" SEAL RING (3 REQUIRED)
- 433 INPUT HOUSING ASSEMBLY
- 434 FORWARD CLUTCH BALL CAPSULE ASSEMBLY
- 435 INPUT HOUSING BUSHING
- 436 FORWARD CLUTCH MOLDED PISTON ASSEMBLY
- 437 COAST CLUTCH BALL CAPSULE ASSEMBLY
- 438 COAST CLUTCH PISTON ASSEMBLY
- 439 FORWARD AND COAST CLUTCH RETURN SPRING ASM.
- 440 RETURN SPRING RETAINING SNAP RING

- 441 COAST CLUTCH APPLY PLATE, "SELECTIVE"
- 442 COAST CLUTCH "WAVE" PLATE
- 443 SINGLE SIDED "OUTSIDE SPLINE" COAST CLUTCH PLATE (3)
- 444 SINGLE SIDED "INSIDE SPLINE" COAST CLUTCH PLATE (3)
- 445 COAST CLUTCH BACKING PLATE
- 446 COAST CLUTCH HOUSING
- 447 FORWARD CLUTCH "WAVE" PLATE
- 448 SINGLE SIDED "OUTSIDE SPLINE" FORWARD CLUTCH PLATE (4)
- 449 SINGLE SIDED "INSIDE SPLINE" FORWARD CLUTCH PLATE (4)
- 450 FORWARD CLUTCH BACKING PLATE
- 451 FORWARD CLUTCH BACKING PLATE SNAP RING "SELECTIVE"

Copyright © 2002 ATSG

Figure 84



Technical Service Information

COMPONENT REBUILD FORWARD AND COAST CLUTCH HOUSING

1. Dis-assemble the forward/coast clutch housing using Figure 84 as a guide.
2. Thoroughly clean all forward and coast clutch parts and dry with compressed air.
3. Thoroughly inspect all forward and coast clutch parts for any wear and/or damage.
4. Inspect the coast clutch piston ball capsule for proper operation, as shown in Figure 85.
5. Inspect the forward/coast clutch housing ball capsule for proper operation (See Figure 85).
6. Place forward clutch housing on a foot press and install J-45134 seal protector on forward clutch housing, as shown in Figure 86.
7. Lubricate the molded seals of the new forward clutch piston with small amount of Trans-Jel®.
8. Install the forward clutch piston, as shown in Figure 86, by rotating into position.
9. Remove J-45134 seal protector.

Continued on Page 60

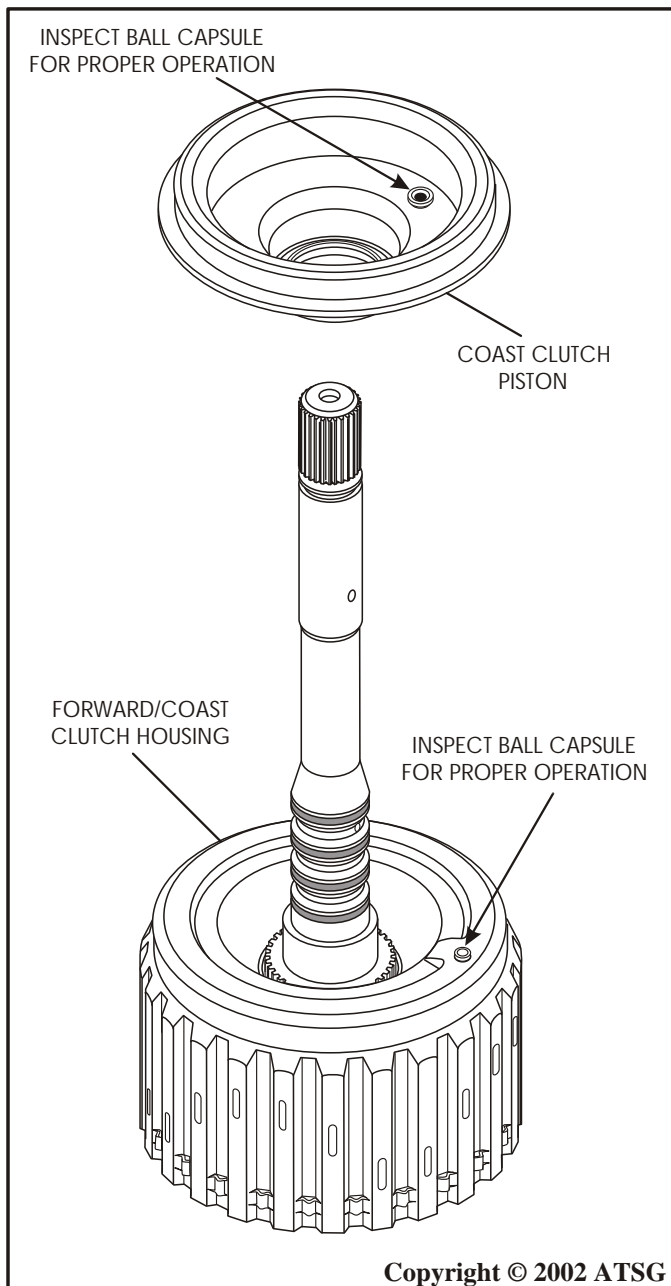

Figure 85

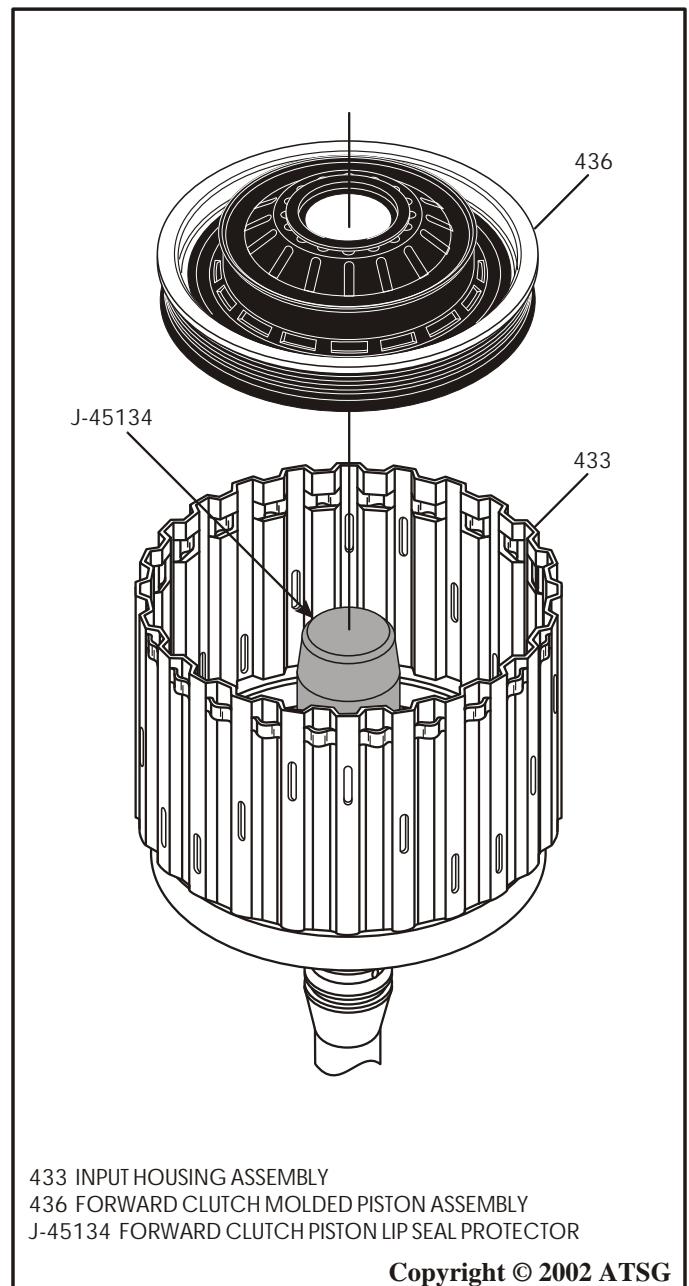

Figure 86



Technical Service Information

COMPONENT REBUILD

FORWARD AND COAST CLUTCH HOUSING (CONT'D)

10. Install J-45132 seal protector on forward clutch housing, as shown in Figure 87.
11. Lubricate the molded inner seal and the inside diameter of the coast clutch piston with small amount of Trans-Jel®. (See Figure 87).
12. Install the coast clutch piston, as shown in Figure 87, by rotating and pushing down into position.
13. Remove J-45132 seal protector.
14. Install the forward/coast clutch return spring and retainer assembly, as shown in Figure 87.
15. Using the foot press, compress return spring and install the snap ring.

Note: GM recommends a "New" snap ring in this location.

16. Ensure that the snap ring is fully seated and release the foot press (See Figures 87 and 88).
17. Measure from the top of the forward clutch housing to the top of the coast clutch piston, as shown in Figure 89.

Notice: Record this as dimension "C".

18. Measure from the top of the forward clutch housing to the top of the forward clutch piston, as shown in Figure 89.

Notice: Record this as dimension "B".

19. Subtract dimension "C" from dimension "B". This answer is now dimension "A".

Notice: Record dimension "A".

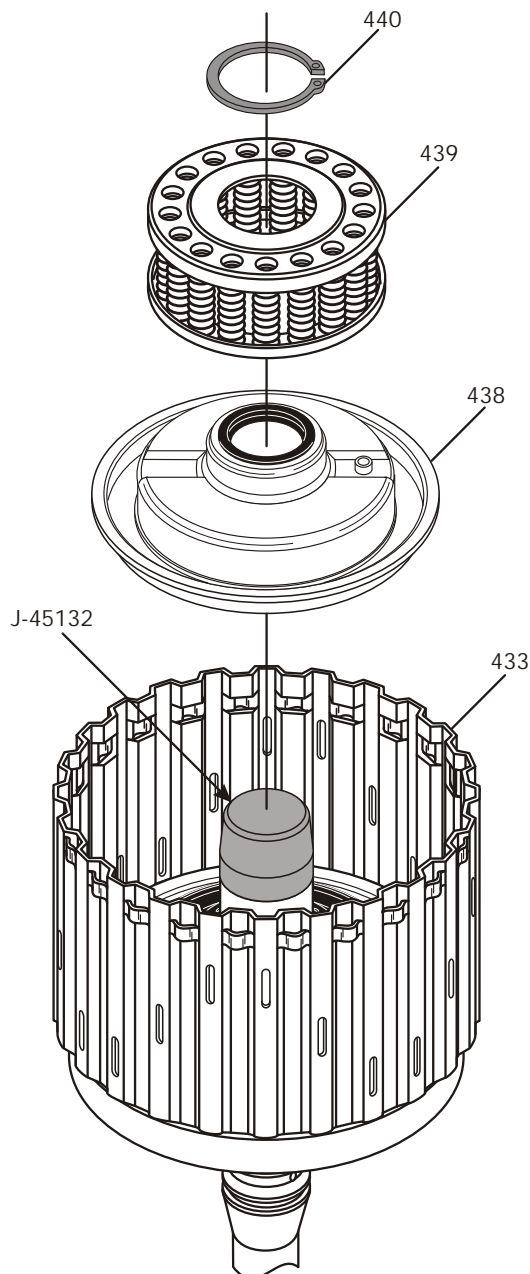

433 INPUT HOUSING ASSEMBLY
 438 COAST CLUTCH PISTON ASSEMBLY
 439 FORWARD AND COAST CLUTCH RETURN SPRING ASM.
 440 RETURN SPRING RETAINING SNAP RING
 J-45132 COAST CLUTCH PISTON LIP SEAL PROTECTOR

Copyright © 2002 ATSG

Figure 87

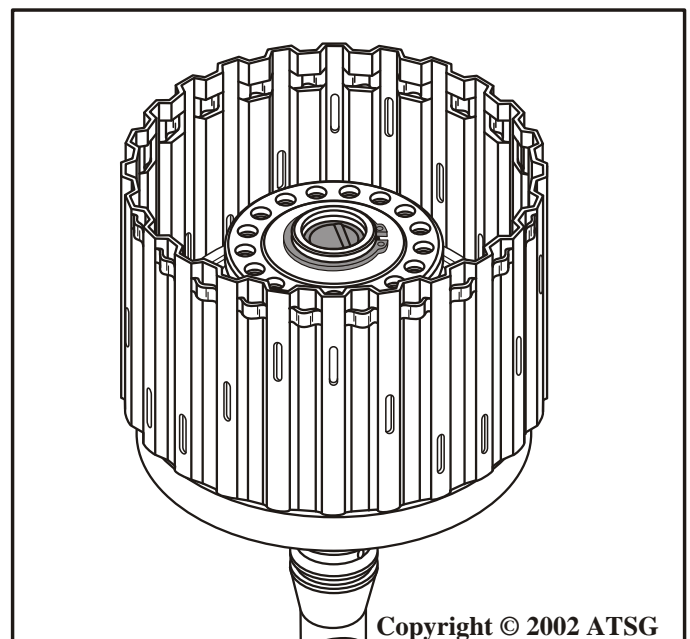

Copyright © 2002 ATSG

Figure 88



Technical Service Information

20. Lay the coast clutch housing on a flat surface in the direction shown in Figure 90.
21. Install the coast clutch backing plate into the coast clutch housing, as shown in Figure 90.
22. Install the coast clutch "single sided" plates beginning with an inside spline plate first and alternating with outside spline plates until you have installed 3 of each, as shown in Figure 90.
Note: In this procedure, lined side must be installed facing down, as shown in Figure 90. Clutch plate amounts may vary by model.
23. Install the coast clutch "Wave" plate on top of the last outside spline plate in the coast clutch housing, as shown in Figure 90.

Continued on Page 62

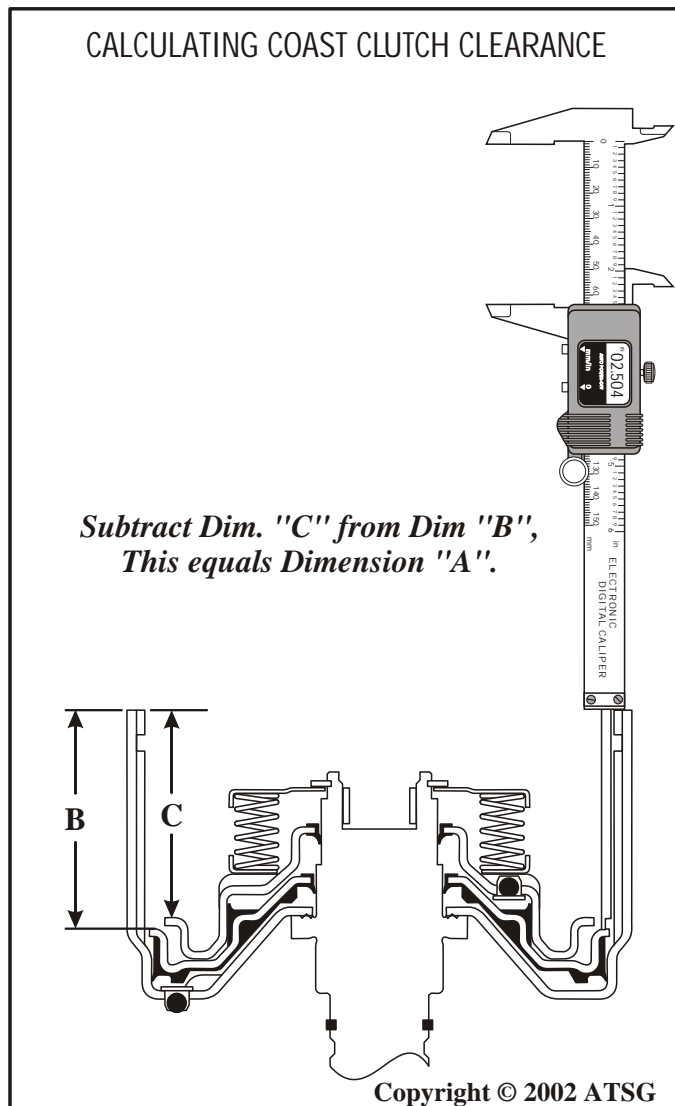

Figure 89

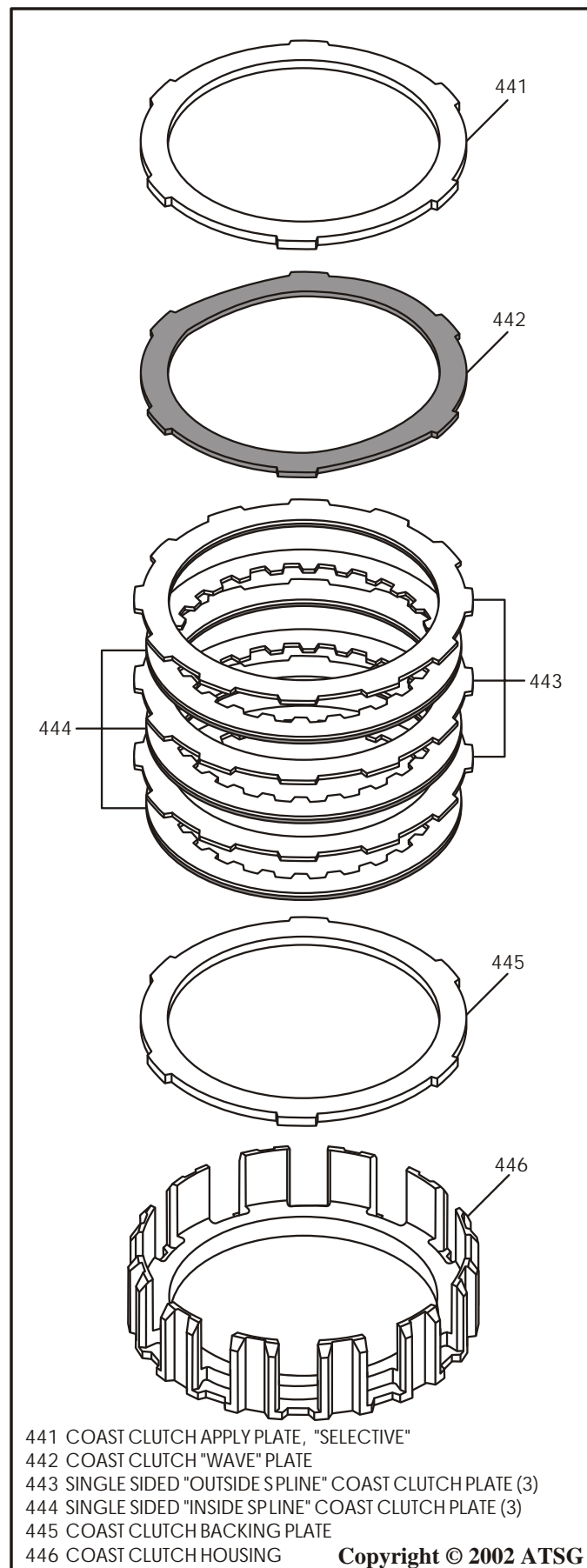

Figure 90



Technical Service Information

COMPLETED COAST CLUTCH HOUSING

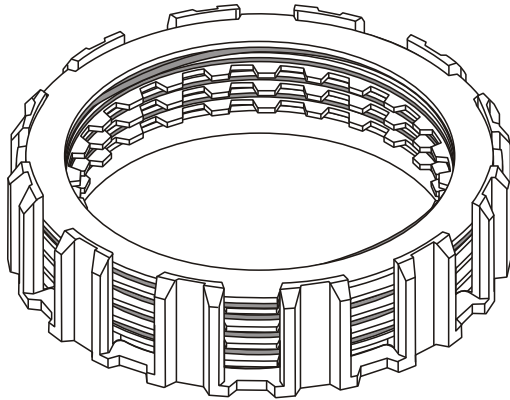

Figure 91

CALCULATING COAST CLUTCH CLEARANCE

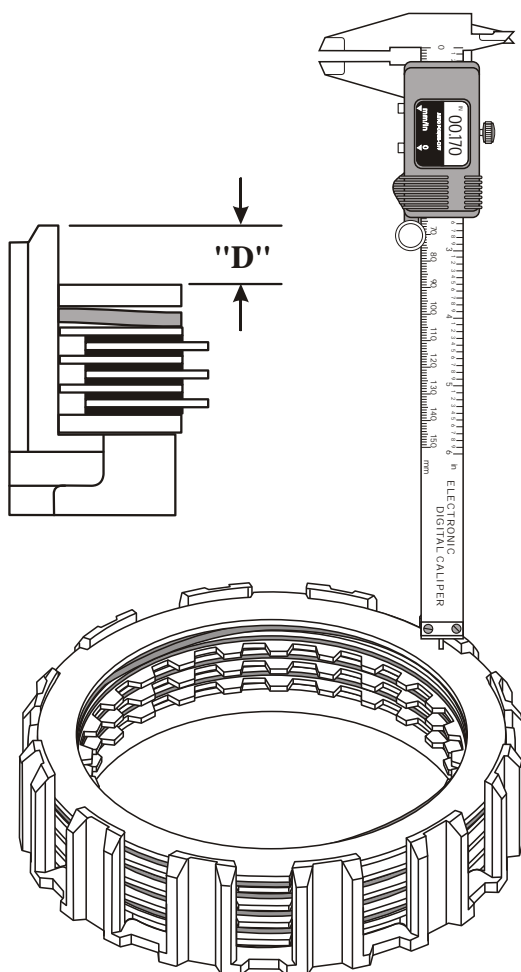

Figure 92

COMPONENT REBUILD

FORWARD AND COAST CLUTCH HOUSING (CONT'D)

24. Install the "Selective" apply plate on top of the wave plate, as shown in Figure 90.

Note: The "Selective" apply plate usually has a number stamped on it for I.D.

25. The coast clutch housing is now complete and should look like the illustration in Figure 91.

26. We are now ready to check for proper coast clutch clearance. This is where we will need the pre-recorded dimensions.

27. Measure the distance from the top of the coast clutch housing to the top of the coast clutch apply plate, as shown in Figure 92.

Notice: Record this as dimension "D".

28. Subtract pre-recorded dimension "A" from dimension "D". This is the coast clutch pack travel, and travel should be as follows: 0.77 mm (.030") to 1.67 mm (.060").

EXAMPLE:

Dimension "B" = 2.504"

Dimension "C" = 2.375"

Subtract dimension "C" from dimension "B" and this = dimension "A".

Dimension "A" = 0.129"

Dimension "D" = 0.170"

Subtract dimension "A" from dimension "D" and this = clutch pack travel.

Clutch travel in this example is 0.041".

29. Change the "Selective" coast clutch apply plate as necessary to obtain proper clearance.

30. Holding the completed coast clutch housing in your left hand and grasping the turbine shaft with your right hand, as shown in Figure 93, index and install the coast clutch housing up into the forward clutch housing, all the way.

31. While holding it in position, turn the assembly over and place it back on the foot press as shown in Figure 94.

32. Install the forward clutch "Wave" plate on top of the coast clutch housing (See Figure 94).

Continued on Page 64



Technical Service Information

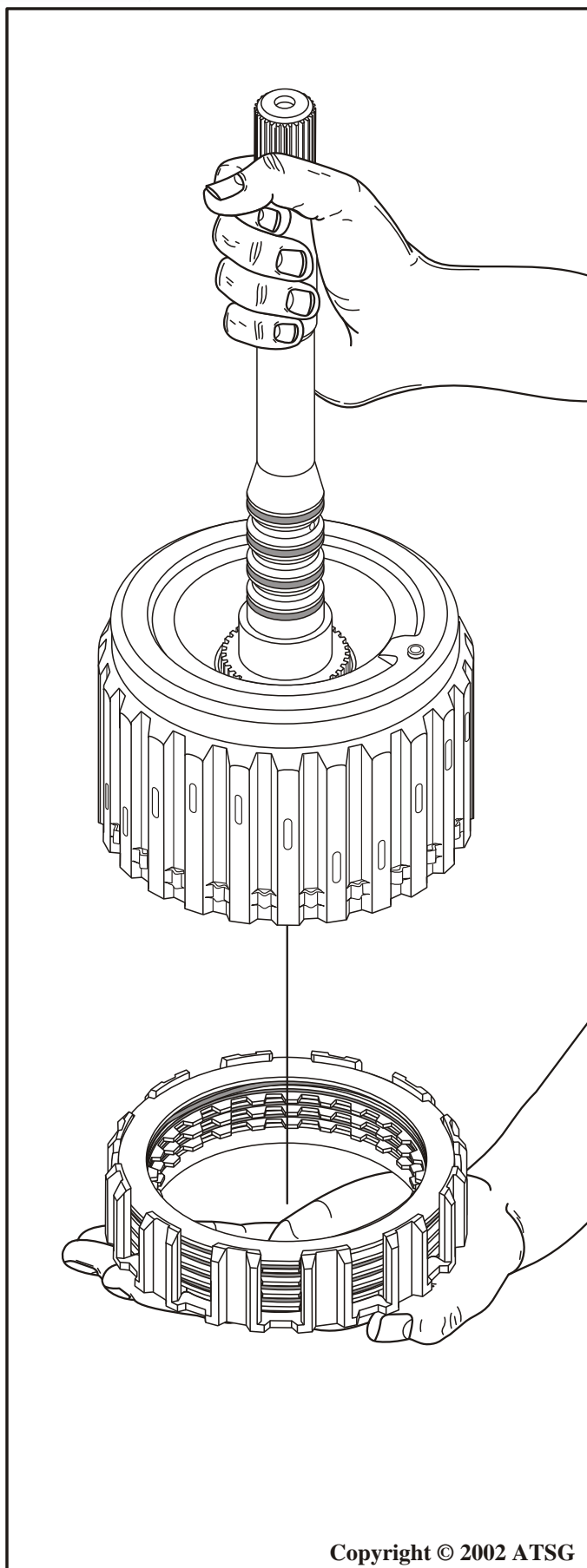

Copyright © 2002 ATSG

Figure 93

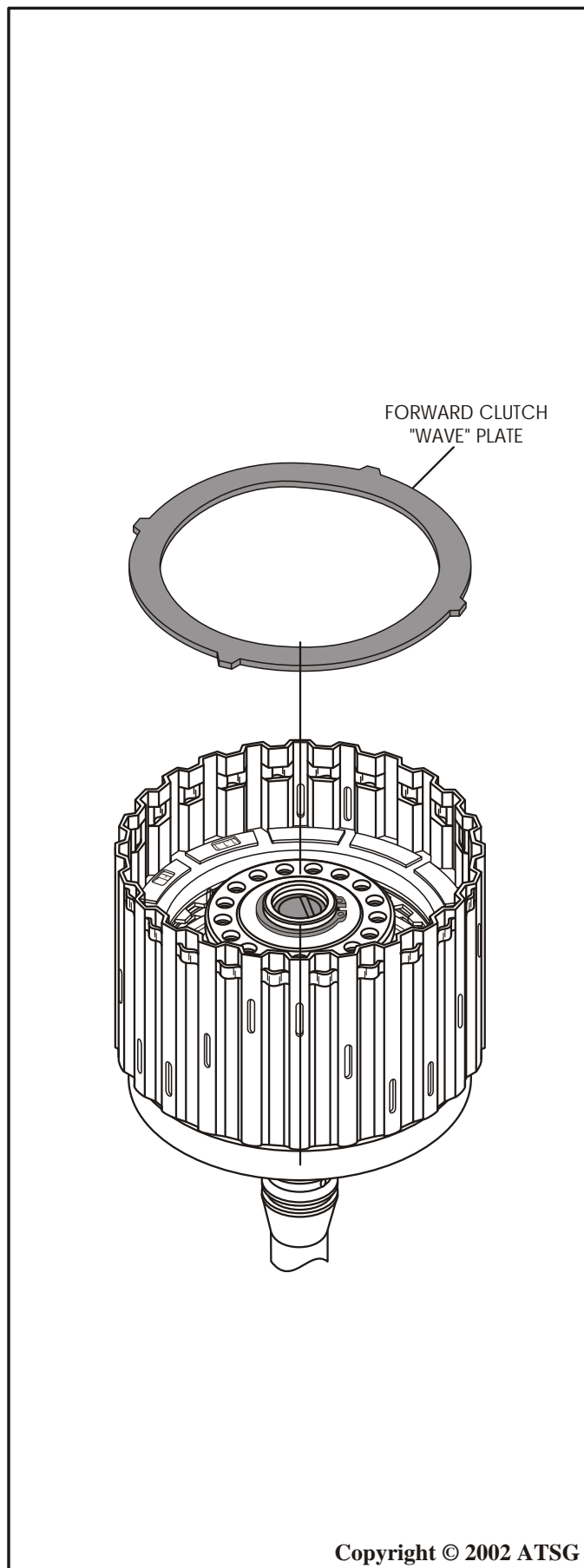

FORWARD CLUTCH
"WAVE" PLATE

Copyright © 2002 ATSG

Figure 94



Technical Service Information

COMPONENT REBUILD

FORWARD AND COAST CLUTCH HOUSING (CONT'D)

33. Install the forward clutch "single sided" plates beginning with an outside spline plate first and alternating with inside spline plates until you have installed 4 of each, as shown in Figure 95.
Note: Lined side must be facing up, as shown in Figure 95. Clutch plate amounts may vary by model.
34. Install forward clutch backing plate on top of the last inside spline plate (See Figure 95).
35. Install the "Selective" backing plate snap ring as shown in Figure 95, and ensure that the snap ring is fully seated against the top of the snap ring groove in forward clutch housing.
36. Install dial indicator on top of forward clutch backing plate, as shown in Figure 96, and zero the dial indicator.

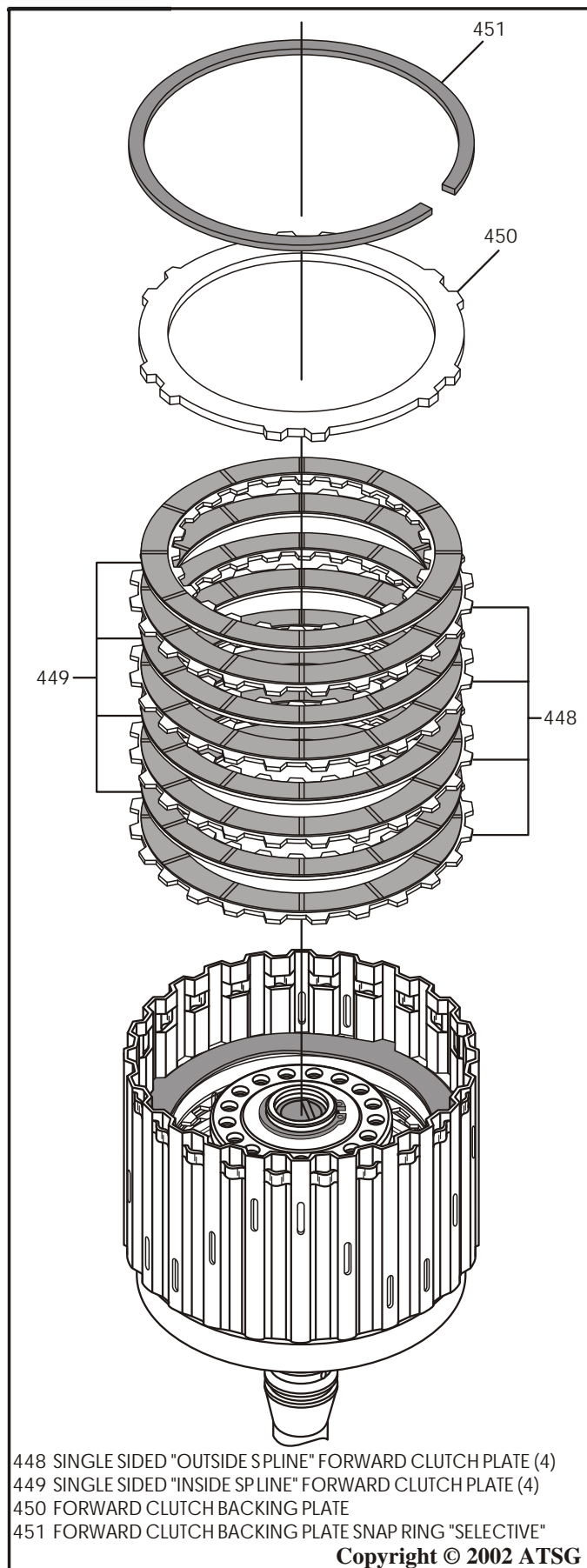

Figure 95

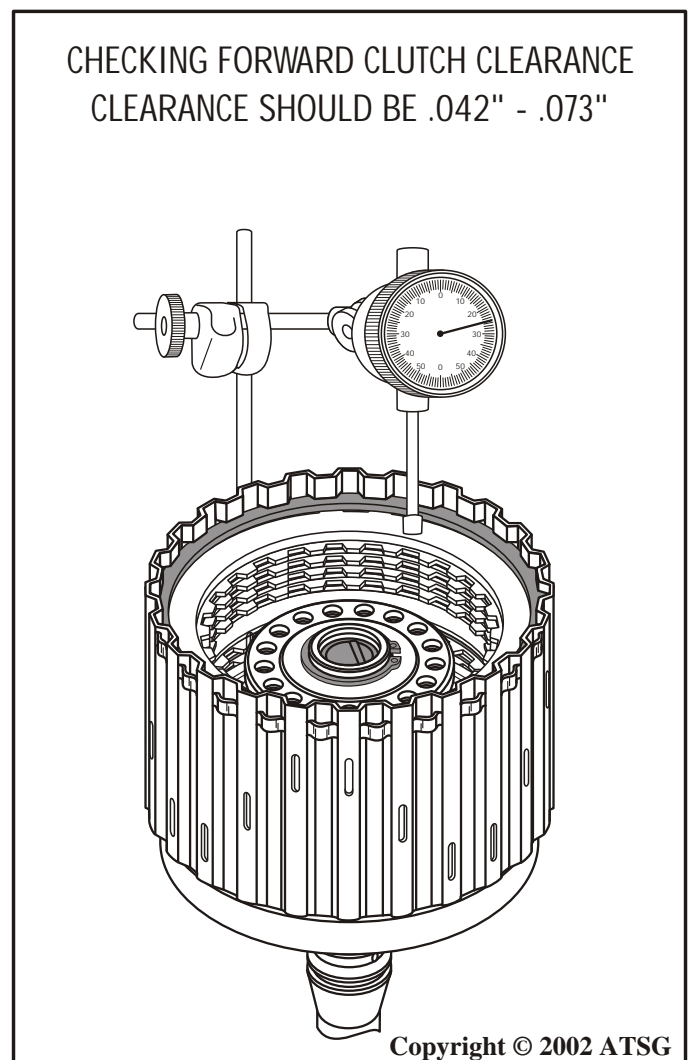

Figure 96



Technical Service Information

37. Forward clutch clearance should be: 1.06 mm (.042") to 1.86 mm (.073"). Change the "Selective" backing plate snap ring as necessary to achieve proper clutch clearance.
 38. Install the one solid seal ring on the turbine shaft using J-45130 installation tool. Refer to Figure 98.
 39. Install the three remaining scarf-cut seal rings as shown in Figure 98, ensuring that the scarfs are not overlapped.
 40. Install the J-45130-3 re-sizing tool, as shown in Figure 97.
- Note: Leave the re-sizing tool in place until ready to install in transmission.**
41. Set completed forward/coast clutch housing aside for the final assembly process.

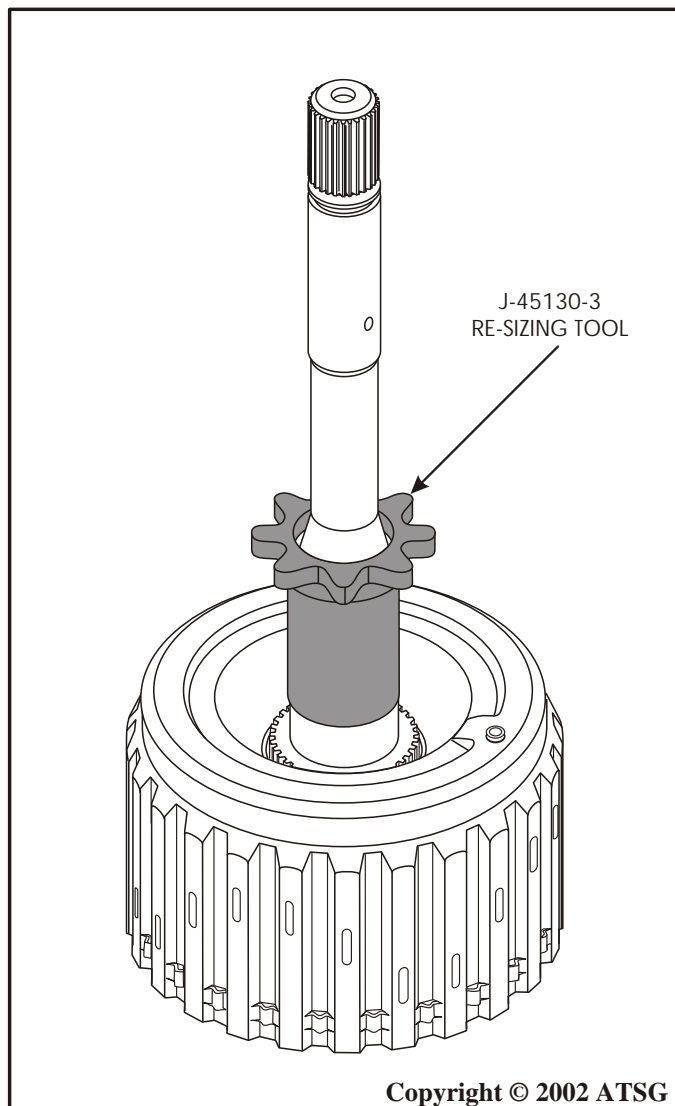

Figure 97

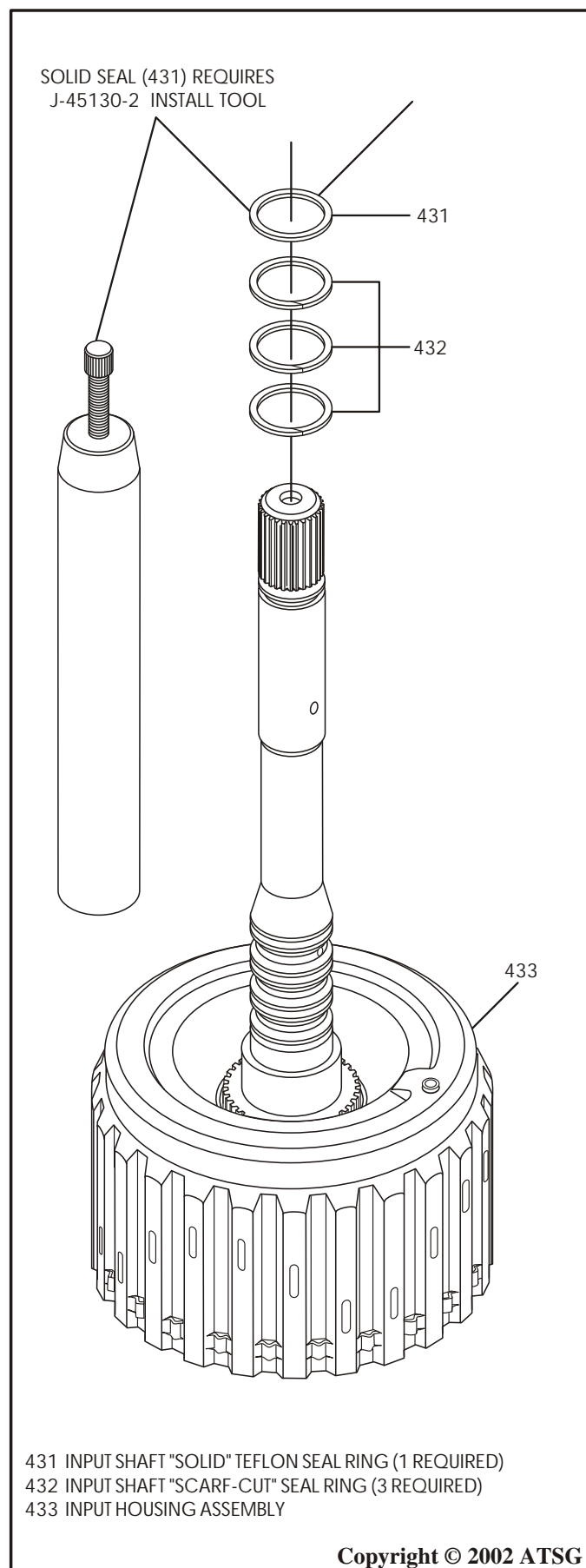
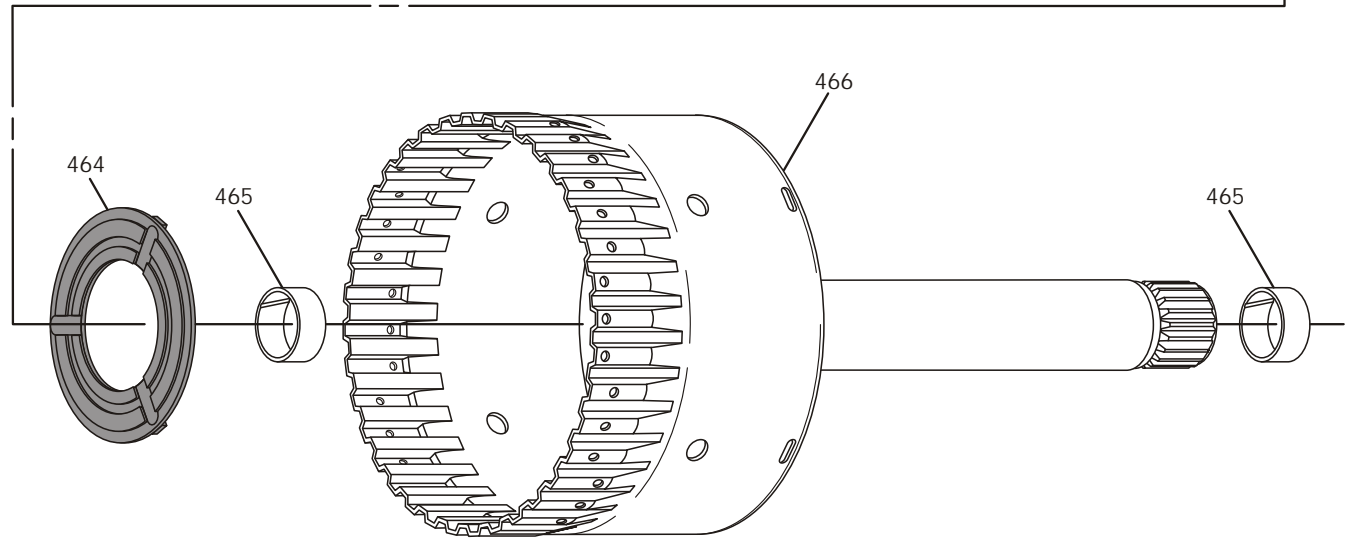
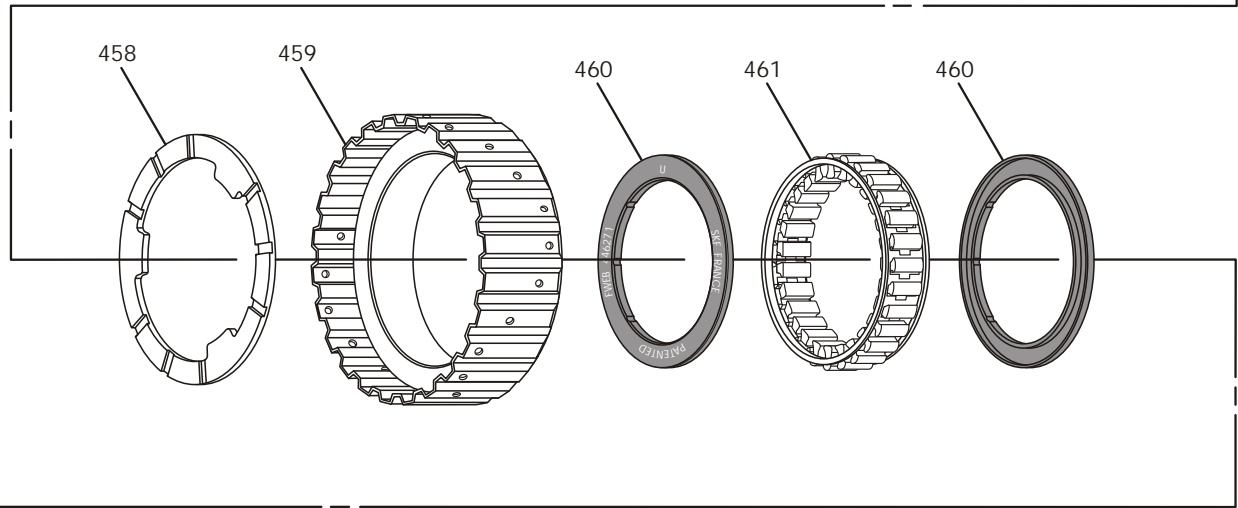
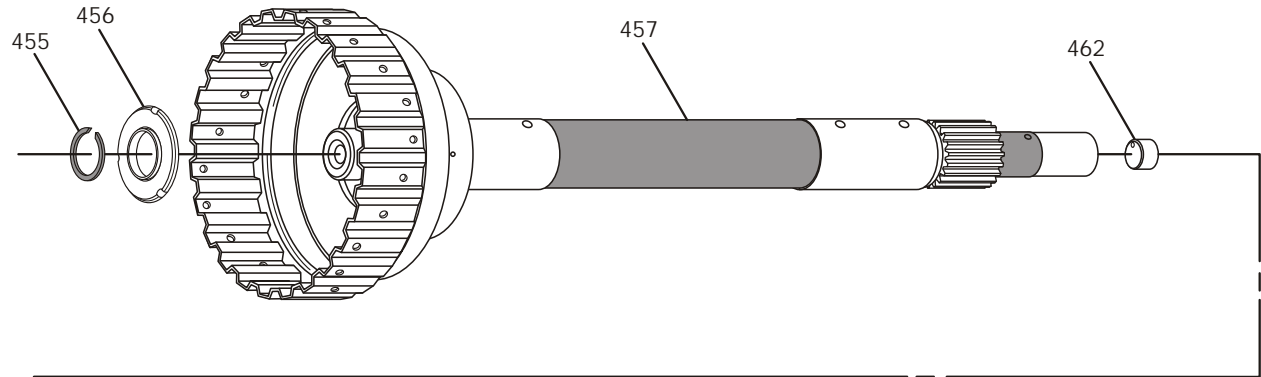

Figure 98



Technical Service Information

FORWARD SPRAG AND DIRECT DRUM AND SHAFT ASSEMBLY



- 455 FORWARD SPRAG INNER RACE THRUST BEARING SNAP RING
- 456 FORWARD SPRAG INNER RACE THRUST BEARING
- 457 INPUT SUN GEAR SHAFT ASSEMBLY
- 458 FORWARD SPRAG OUTER RACE THRUST WASHER
- 459 FORWARD SPRAG OUTER RACE ASSEMBLY
- 460 FORWARD SPRAG END BEARINGS (2)

- 461 FORWARD SPRAG AND CAGE ASSEMBLY
- 462 ORIFICED CUP PLUG FOR LUBRICATION
- 464 OUTER RACE TO DIRECT DRUM THRUST WASHER
- 465 DIRECT DRUM AND SHAFT BUSHINGS (2)
- 466 DIRECT DRUM AND SHAFT ASSEMBLY

Copyright © 2002 ATSG

Figure 99



Technical Service Information

COMPONENT REBUILD FORWARD SPRAG ASSEMBLY

1. Dis-assemble the forward sprag assembly using Figure 99 as a guide.

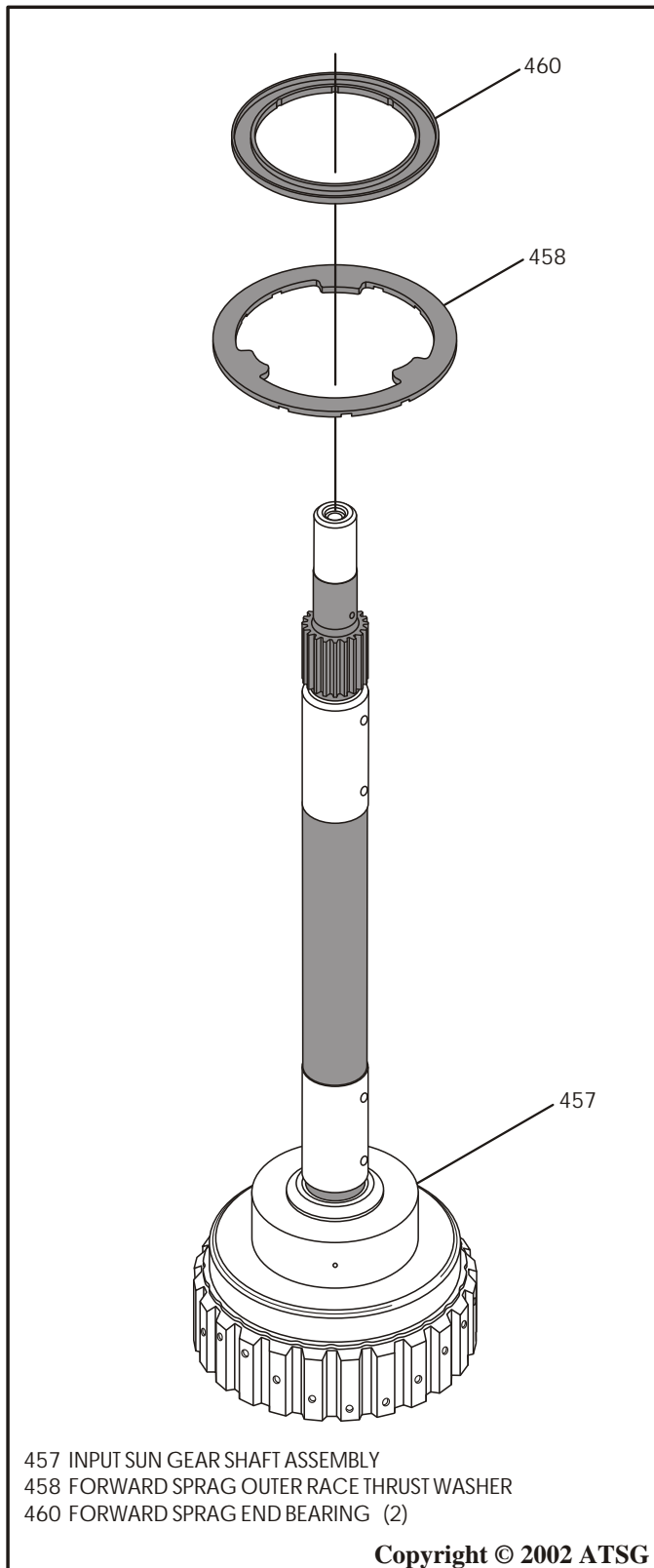

Figure 100

2. Clean all forward sprag parts thoroughly and dry with compressed air.
3. Inspect all forward sprag parts thoroughly for any wear and/or damage. Replace as necessary.
4. Stand sun gear shaft up on the hub as shown in Figure 100, on a flat work surface.
5. Install thrust washer (458) on sun gear hub and shaft, as shown in Figure 100.
6. Install one forward sprag end bearing on sun gear hub and shaft, as shown in Figure 100.
7. Install the forward sprag cage assembly into the outer race **exactly** as shown in Figure 101, with the "windows" to the left, and ensure that the outer race is arranged as shown. Refer to Figure 101.

Continued on Page 68

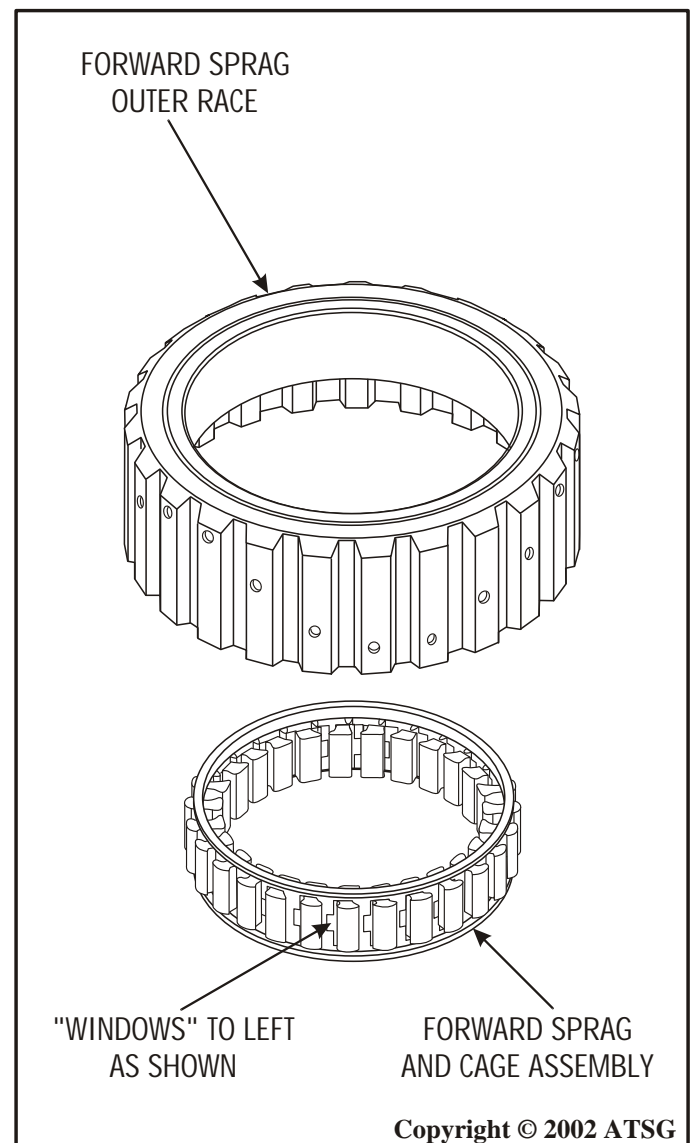

Figure 101



Technical Service Information

COMPONENT REBUILD FORWARD SPRAG ASSEMBLY (CONT'D)

8. Install the pre-assembled forward sprag cage and outer race onto the inner race in direction shown in Figure 102, by rotating in a clockwise motion.

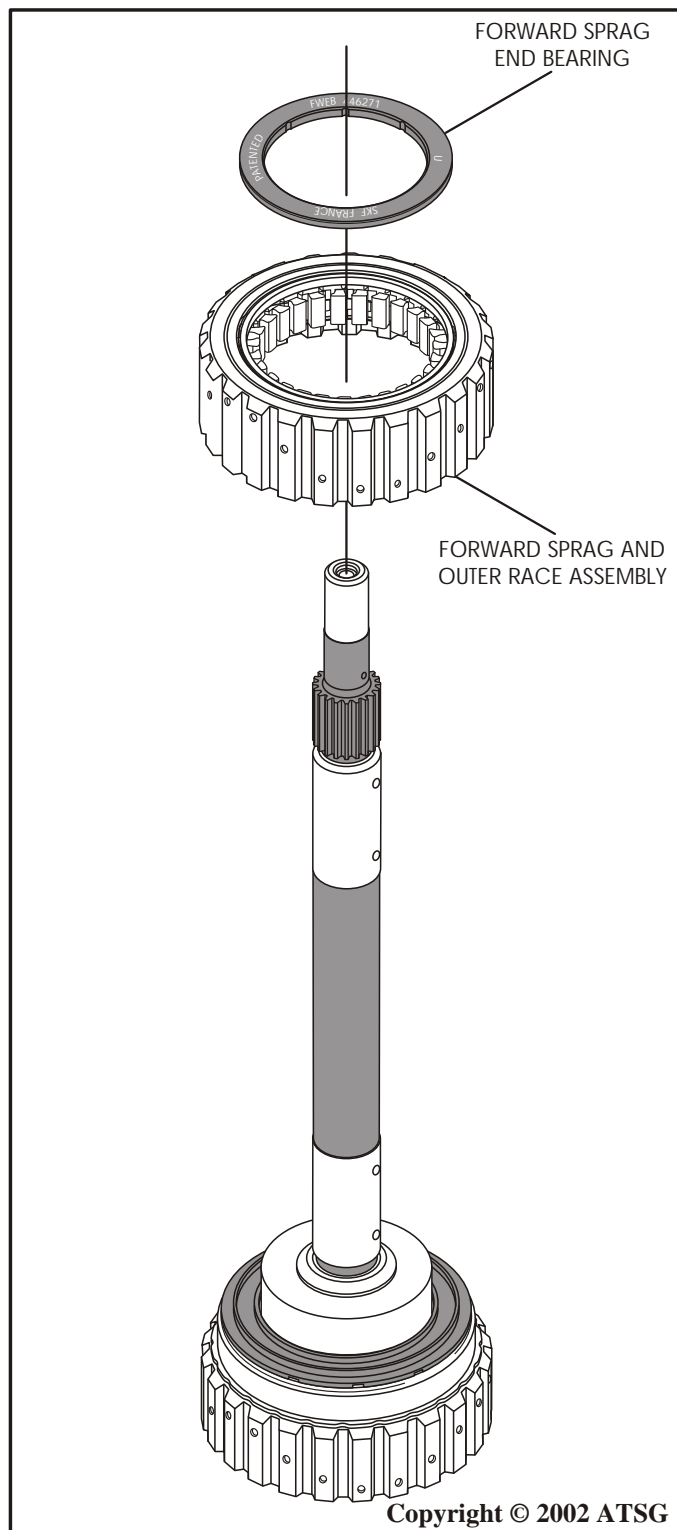

Figure 102

9. Install the other forward sprag end bearing in the direction shown in Figure 102, with the smooth side facing up.
10. Check the forward sprag for proper operation as shown in Figure 103.

Note: *Forward Sprag Outer Race should freewheel clockwise and lock counter-clockwise, as shown in Figure 103.*

11. Set the completed forward sprag and sun gear shaft assembly aside for final assembly.

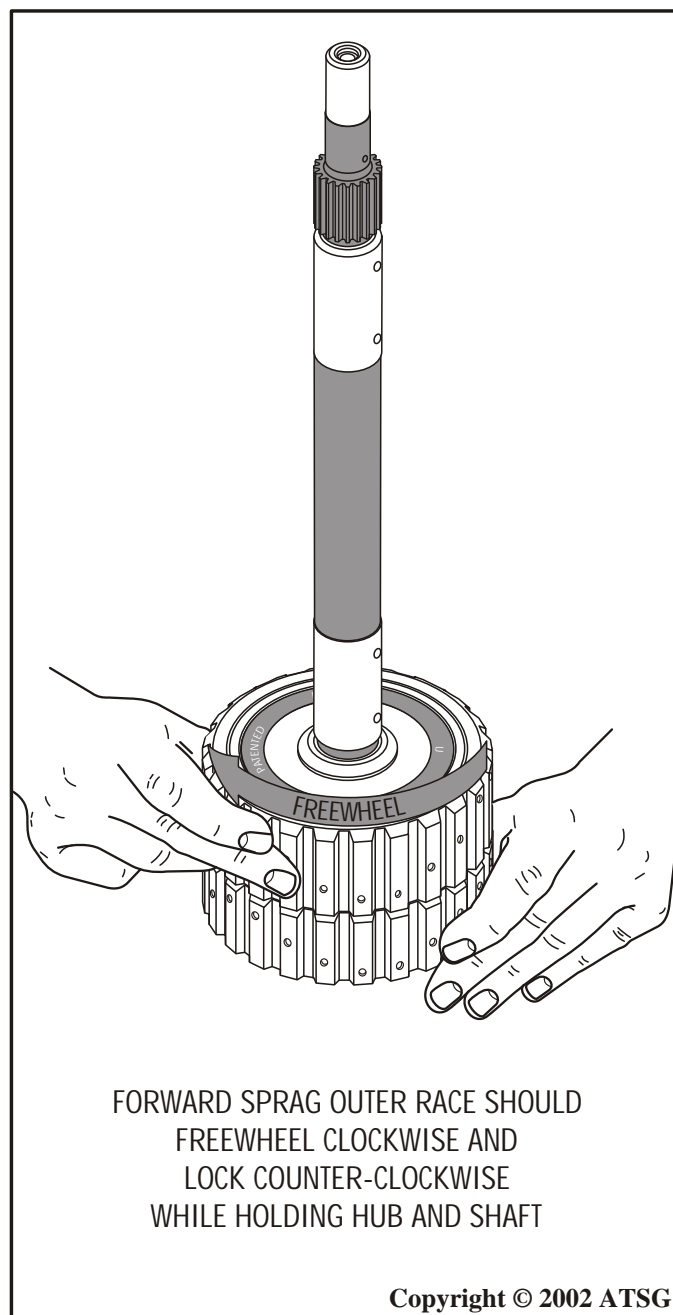

Figure 103



Technical Service Information

COMPONENT REBUILD DIRECT CLUTCH HUB AND WASHER

1. Install the direct clutch hub to forward sprag outer race thrust washer into the direct clutch hub and shaft assembly in the direction shown in Figure 104, and retain with a small amount of Trans-Jel®.
2. Set the completed assembly aside for the final transmission assembly process.

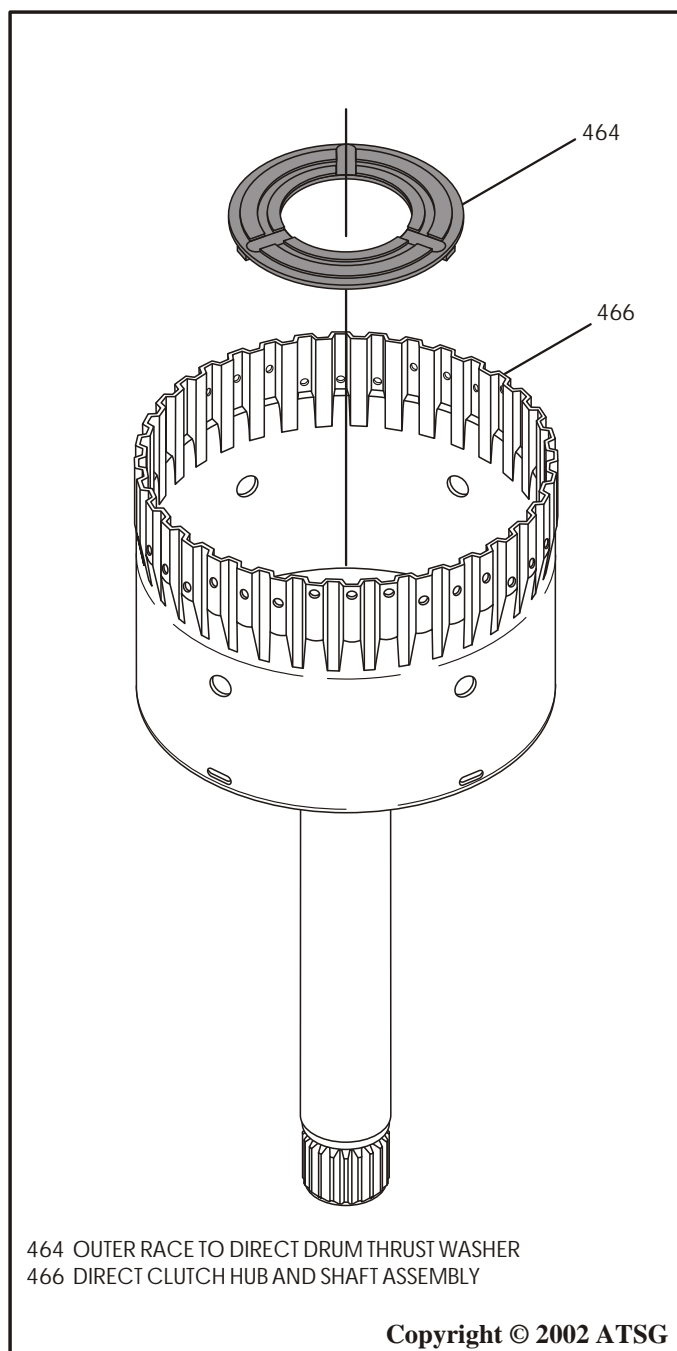

Figure 104

COMPONENT REBUILD O.D. CLUTCH HUB/INTERMEDIATE SPRAG

1. Place the overdrive clutch hub and intermediate sprag assembly on flat work surface, as shown in Figure 105.
2. The intermediate sprag outer race is held on with a pressed on metal retainer, as shown in Figure 105, and can be removed easily with 2 screwdrivers as shown in Figure 105.
3. After removing the metal retainer dis-assemble the remainder of the intermediate sprag using Figure 106 as a guide.
4. Clean all intermediate sprag parts thoroughly and dry with compressed air.
5. Inspect all intermediate sprag parts thoroughly for any wear and/or damage.

Continued on Page 70

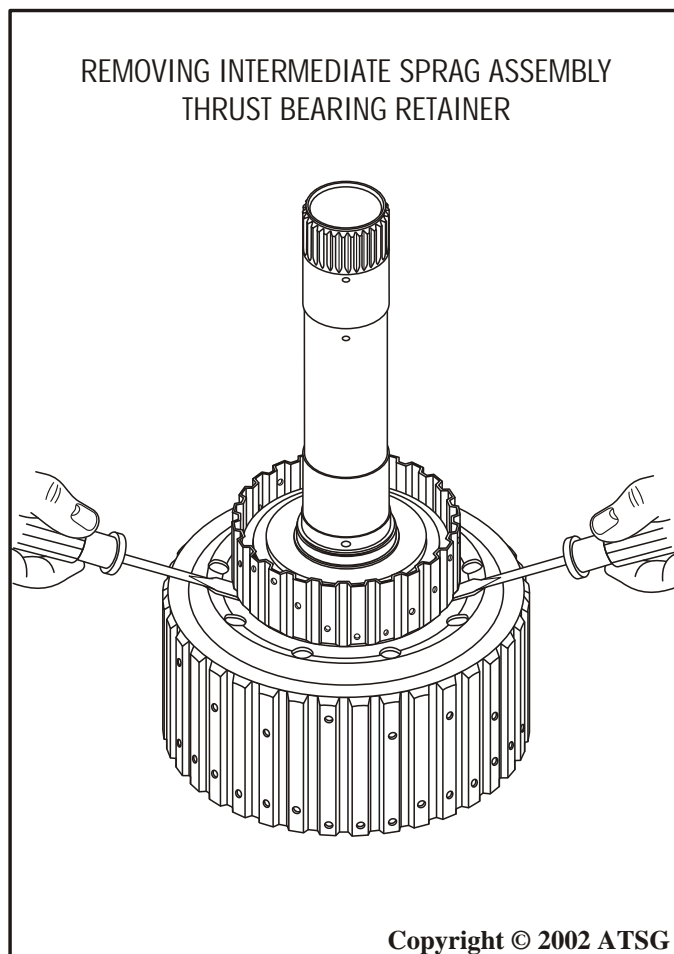
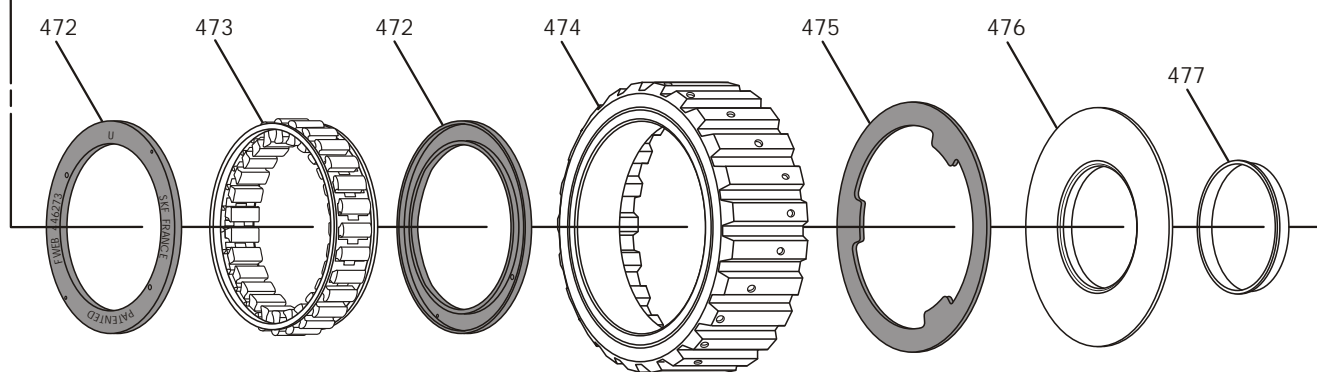
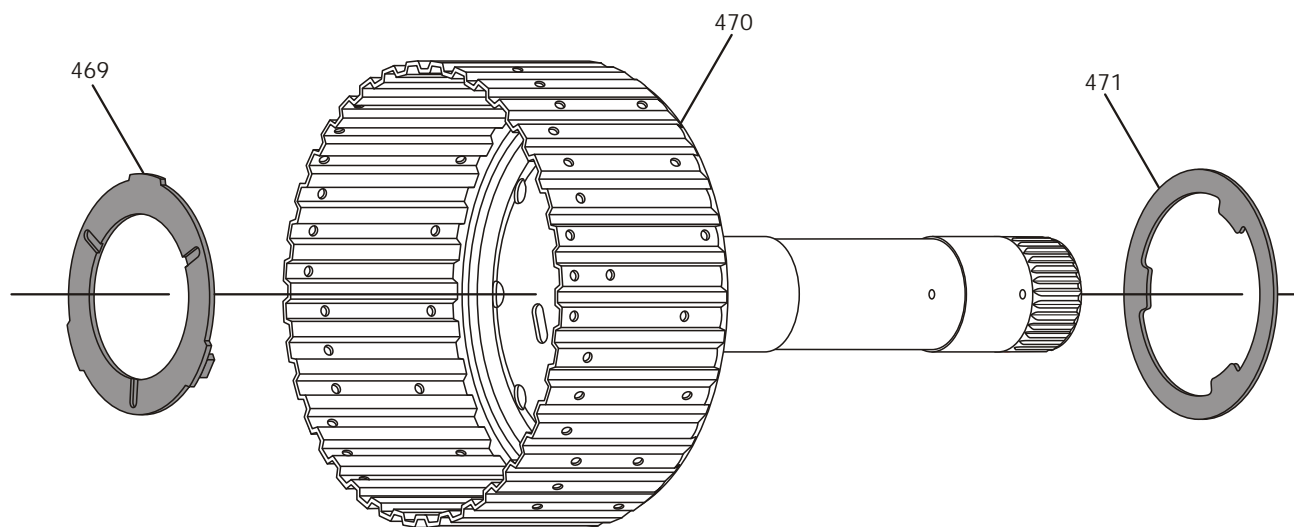

Figure 105



Technical Service Information

INTERMEDIATE SPRAG ASSEMBLY



- 469 DIRECT CLUTCH HUB TO OVERDRIVE/REVERSE CLUTCH HUB THRUST WASHER
- 470 OVERDRIVE AND REVERSE CLUTCH HUB ASSEMBLY
- 471 INTERMEDIATE SPRAG FRONT THRUST WASHER
- 472 INTERMEDIATE SPRAG END BEARINGS
- 473 INTERMEDIATE SPRAG AND CAGE ASSEMBLY
- 474 INTERMEDIATE SPRAG OUTER RACE ASSEMBLY
- 475 INTERMEDIATE SPRAG REAR THRUST WASHER
- 476 INTERMEDIATE SPRAG THRUST BEARING ASSEMBLY
- 477 INTERMEDIATE SPRAG THRUST BEARING RETAINER

Copyright © 2002 ATSG

Figure 106



Technical Service Information

O.D. CLUTCH HUB/INTERMEDIATE SPRAG (CONT'D)

6. Place the overdrive clutch hub on a flat surface with shaft facing up, as shown in Figure 107.
7. Install intermediate sprag outer race thrust washer, as shown in Figure 107.
8. Install one intermediate sprag end bearing on top of the thrust washer in the direction shown in Figure 107.
9. Install the intermediate sprag cage assembly in the outer sprag race *exactly* as shown in Figure 108, with the "windows" to the left, and ensure that the outer race is arranged as shown. Refer to Figure 108.

Continued on Page 72

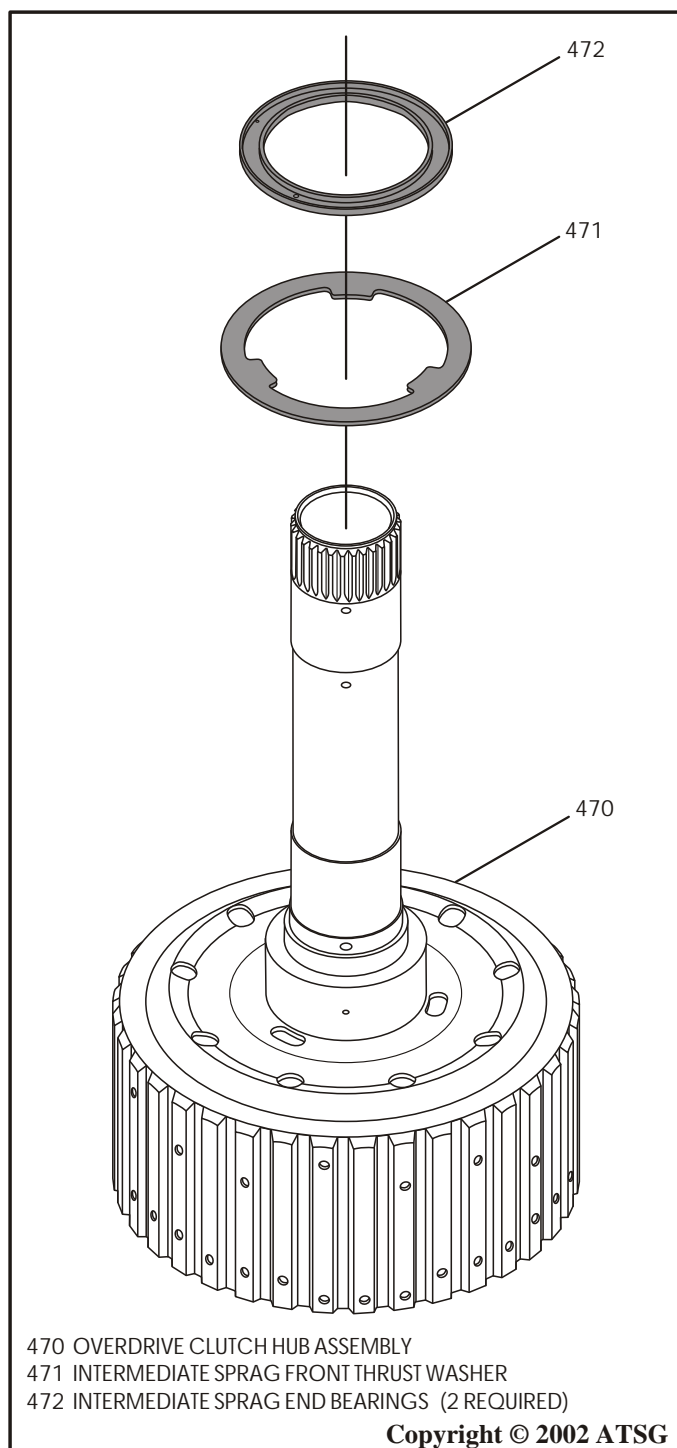

Figure 107

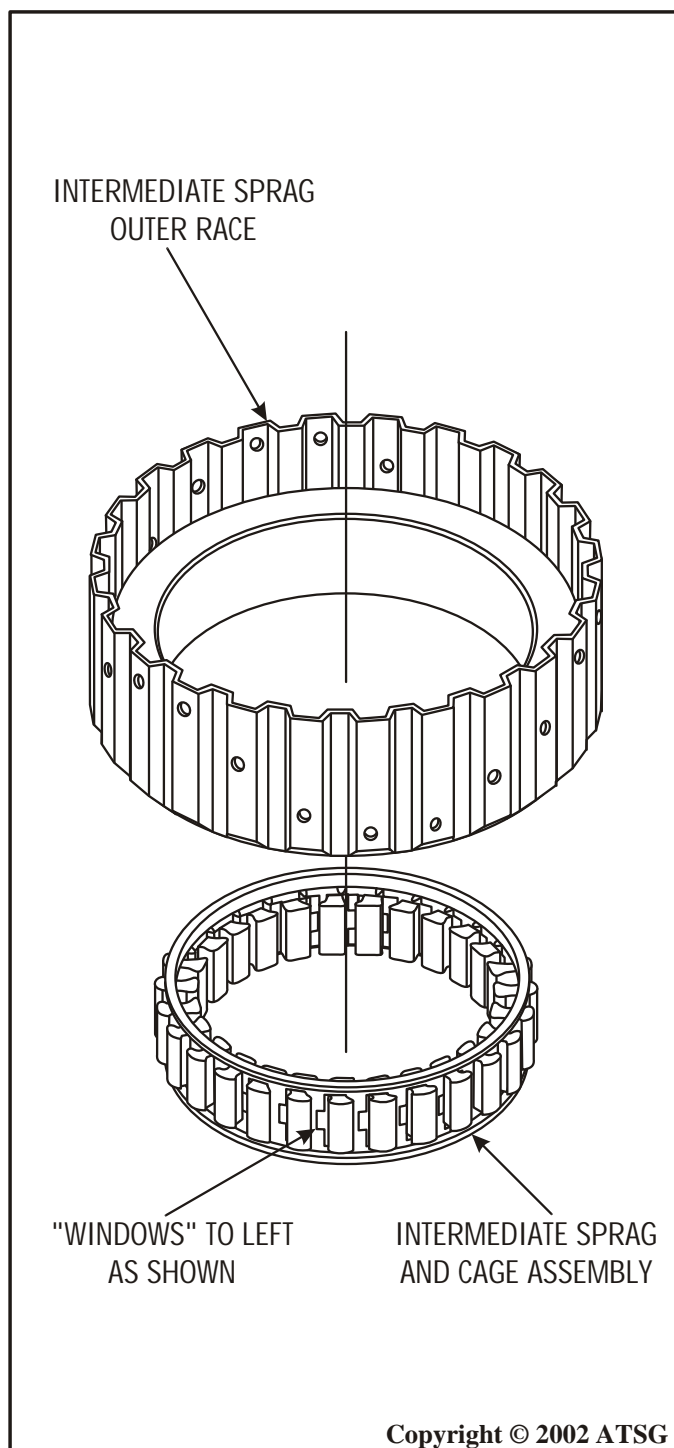

Figure 108



Technical Service Information

O.D. CLUTCH HUB/INTERMEDIATE SPRAG (CONT'D)

10. Install the pre-assembled intermediate sprag cage and outer race assembly onto the inner race, in the direction shown in Figure 109, by rotating with a clockwise motion.

11. Ensure now that the outer race freewheels in a clockwise direction and holds in the counter clockwise direction, as shown in Figure 110.

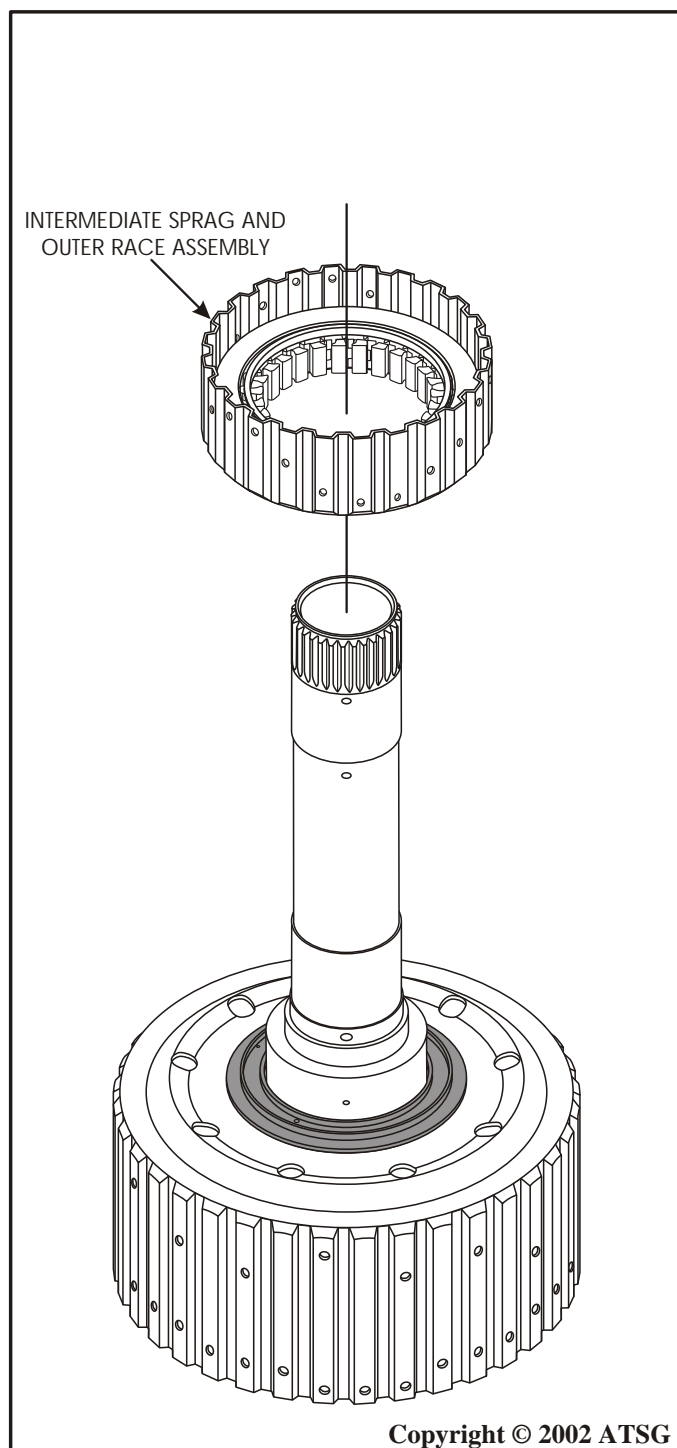

Figure 109

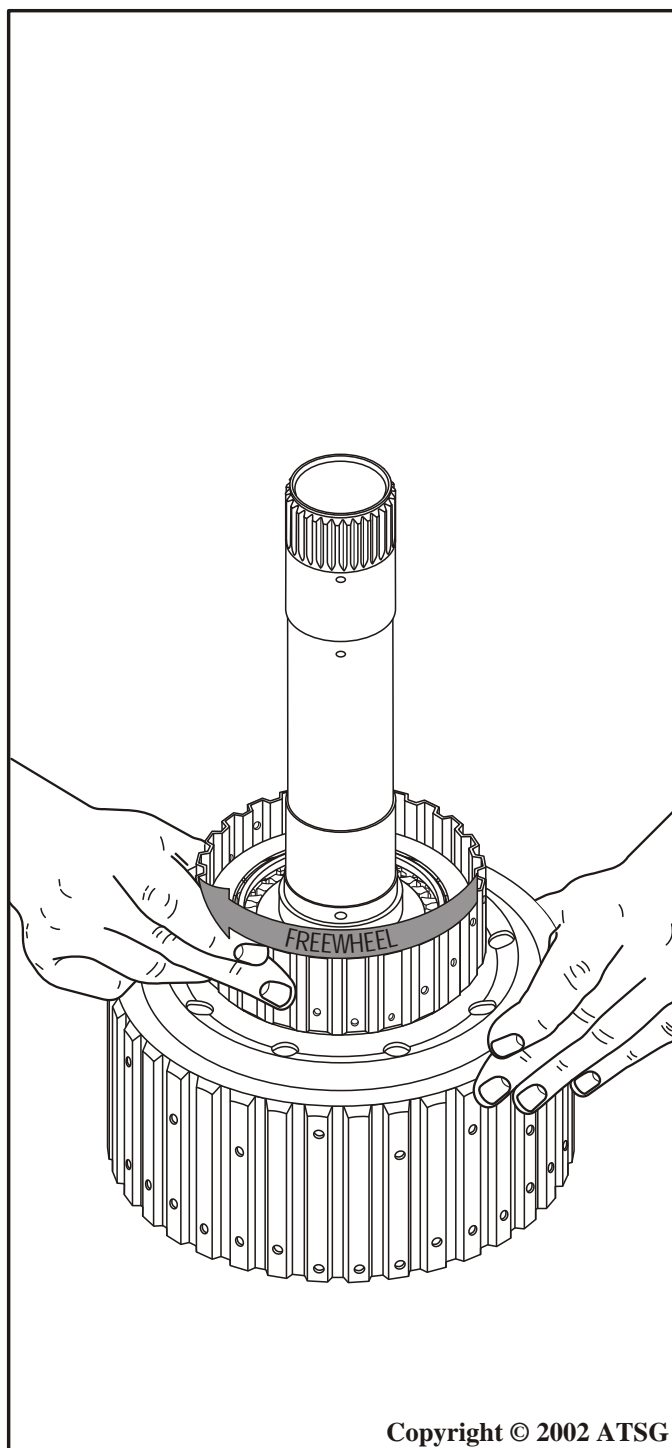

Figure 110



Technical Service Information

12. Install the other intermediate sprag end bearing in the direction shown in Figure 111, with the smooth side facing up.
13. Install another intermediate sprag thrust washer on top of the end bearing (See Figure 111).
14. Install the intermediate sprag thrust bearing, as shown in Figure 112 with the lip facing up, on top of the thrust washer.
15. Install a "New" retainer (477) on top of thrust bearing, as shown in Figure 112.

Continued on Page 74

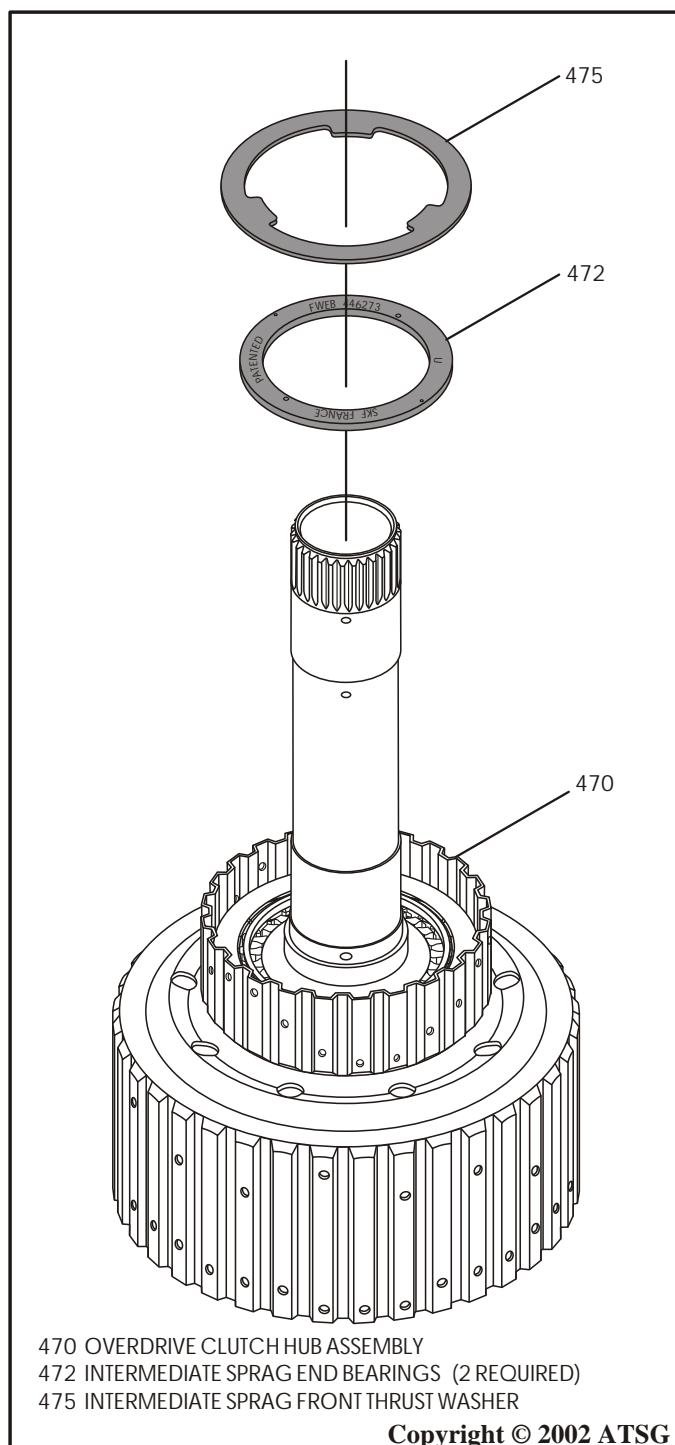

Figure 111

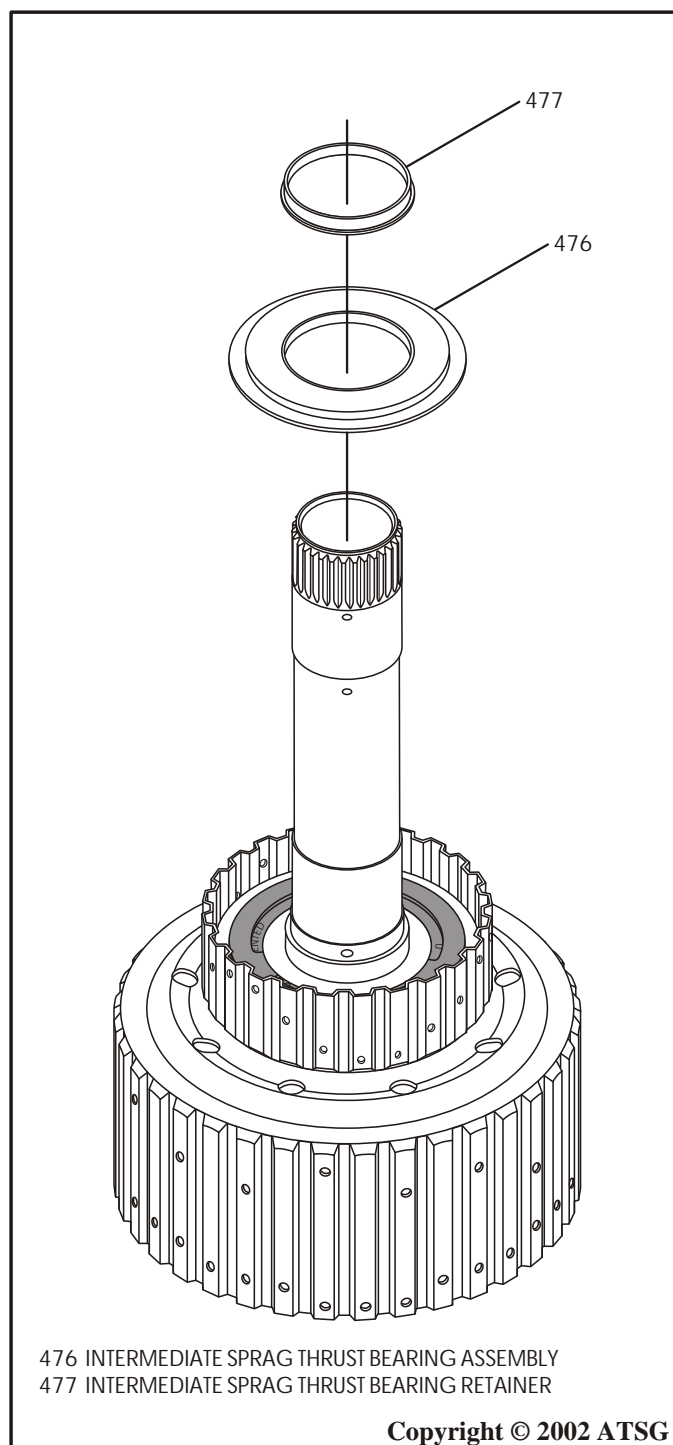

Figure 112



Technical Service Information

O.D. CLUTCH HUB/INTERMEDIATE SPRAG (CONT'D)

16. Ensure that the "New" retainer is fully seated, shown in Figure 113.
17. Check for proper sprag freewheel one more time referring to Figure 110.
18. Turn the assembly over and install the thrust washer, as shown in Figure 114, Retain the thrust washer with small amount of Trans-Jel®.
19. Set the completed overdrive clutch hub and intermediate sprag assembly aside for the final transmission assembly process.

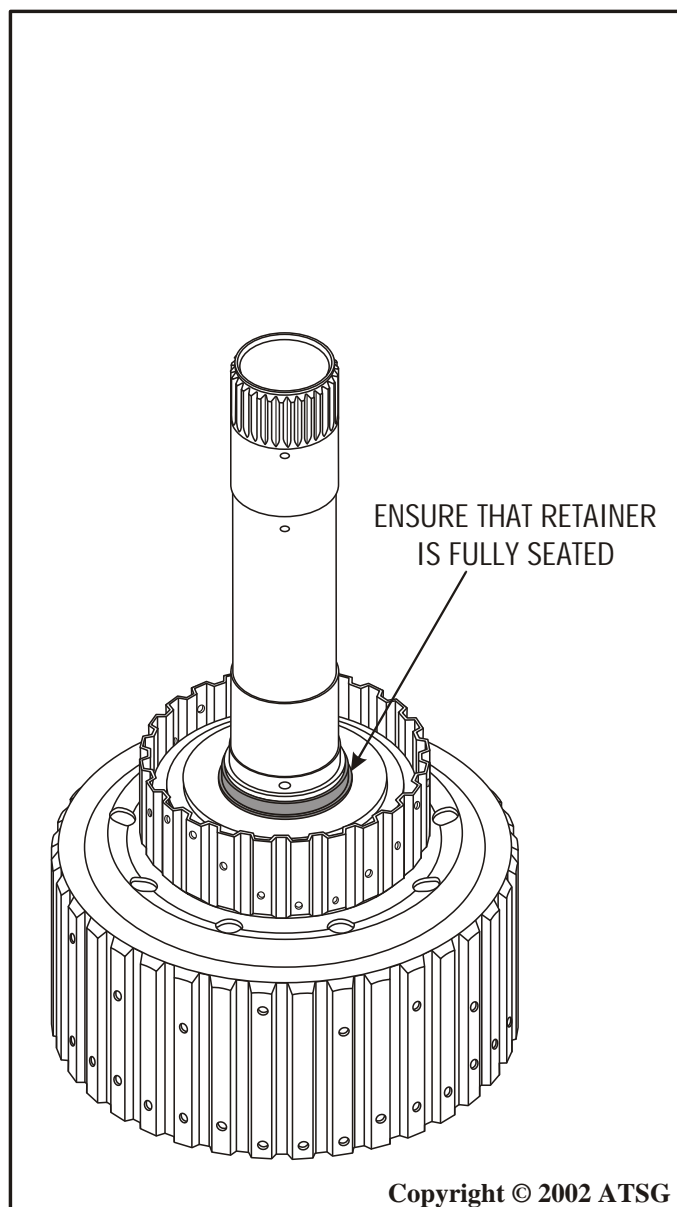

Figure 113

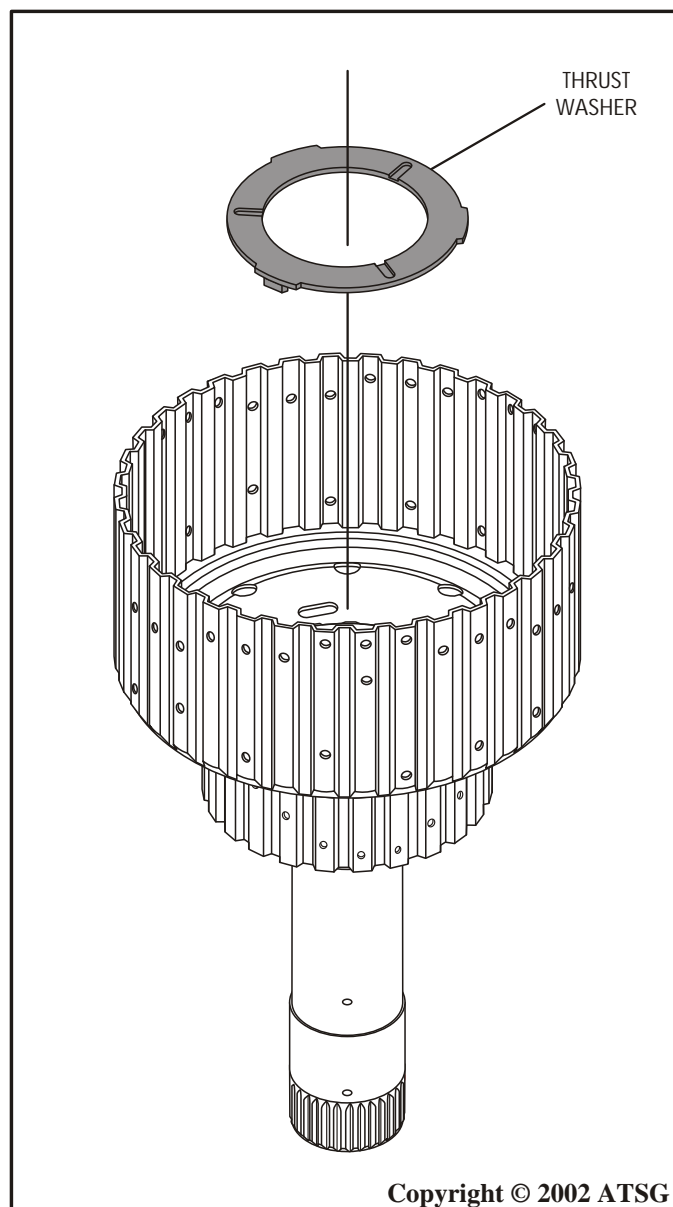
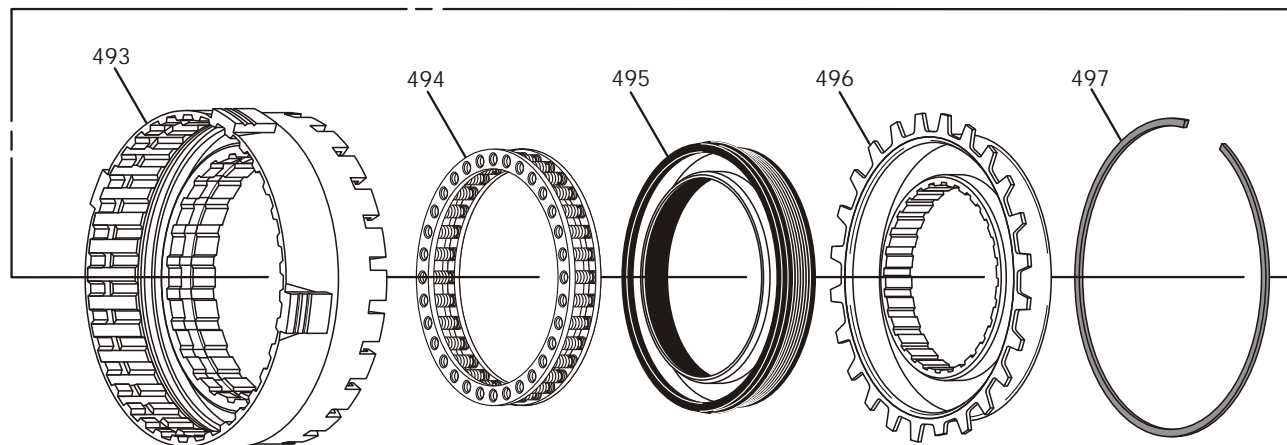
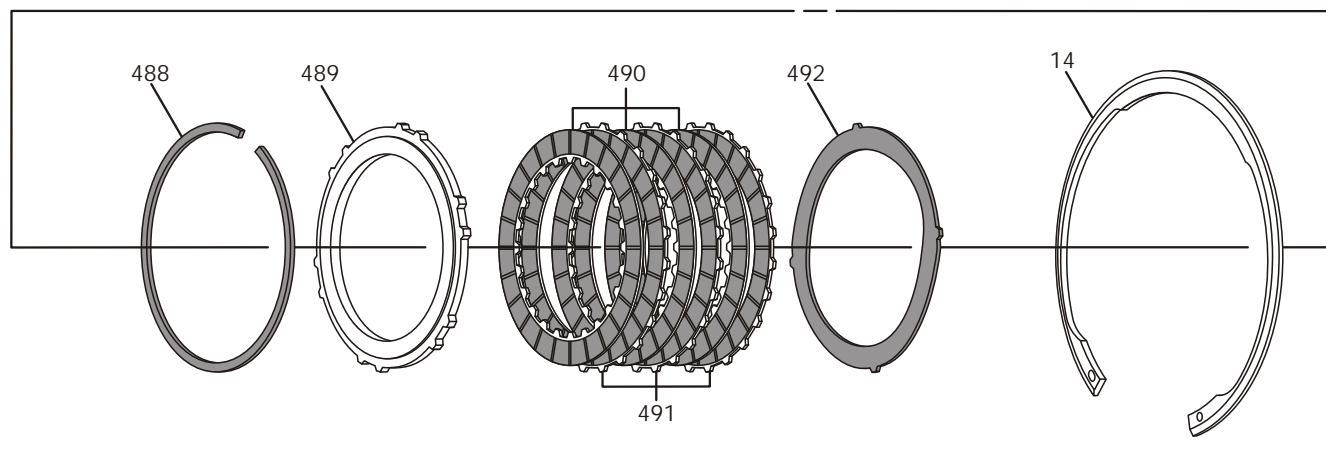
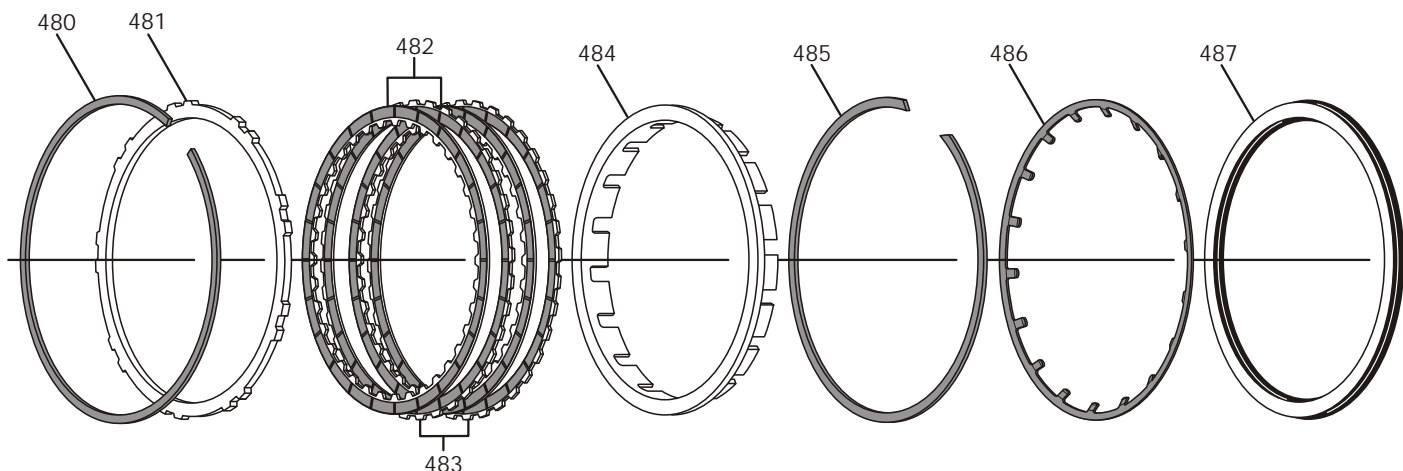

Figure 114



Technical Service Information

INTERMEDIATE AND OVERDRIVE CLUTCH HOUSING ASSEMBLY



- 14 INT./O.D. HOUSING TO MAIN CASE SNAP RING (SELECTIVE)
- 480 OVERDRIVE CLUTCH BACKING PLATE SNAP RING (SELECTIVE)
- 481 OVERDRIVE CLUTCH BACKING PLATE
- 482 OVERDRIVE CLUTCH "INSIDE SPLINE" SINGLE SIDED PLATES (2)
- 483 OVERDRIVE CLUTCH "OUTSIDE SPLINE" SINGLE SIDED PLATES (2)
- 484 OVERDRIVE CLUTCH APPLY RING SPACER
- 485 OVERDRIVE CLUTCH BELLVILLE RETURN SPRING SNAP RING
- 486 OVERDRIVE CLUTCH BELLVILLE RETURN SPRING
- 487 OVERDRIVE CLUTCH PISTON ASSEMBLY
- 488 INTERMEDIATE CLUTCH BACKING PLATE SNAP RING (SELECTIVE)

- 489 INTERMEDIATE CLUTCH BACKING PLATE
- 490 INTERMEDIATE CLUTCH "INSIDE SPLINE" SINGLE SIDED PLATES (3)
- 491 INTERMEDIATE CLUTCH "OUTSIDE SPLINE" SINGLE SIDED PLATES (3)
- 492 INTERMEDIATE CLUTCH "WAVE" PLATE
- 493 INTERMEDIATE/OVERDRIVE CLUTCH HOUSING
- 494 INTERMEDIATE CLUTCH RETURN SPRING ASSEMBLY
- 495 INTERMEDIATE CLUTCH PISTON ASSEMBLY
- 496 INTERMEDIATE CLUTCH PISTON HOUSING
- 497 INTERMEDIATE CLUTCH PISTON HOUSING RETAINING RING

Copyright © 2002 ATSG

Figure 115



Technical Service Information

COMPONENT REBUILD

O.D. AND INTERMEDIATE CLUTCH HOUSING

1. Dis-assemble the overdrive and intermediate clutch housing assembly, using Figure 115 as a guide.
2. Clean all overdrive and intermediate clutch parts thoroughly and dry with compressed air.
3. Inspect all overdrive and intermediate clutch parts thoroughly for the following:
 - o Plugged feed passages
 - o Worn or damaged splines
 - o Damaged or worn springs
 - o Damaged or worn pistons
 - o Damaged or worn clutch plates
4. Lubricate molded intermediate clutch piston with small amount of Trans-Jel® and install it into intermediate clutch housing with rotating motion, as shown in Figure 116.

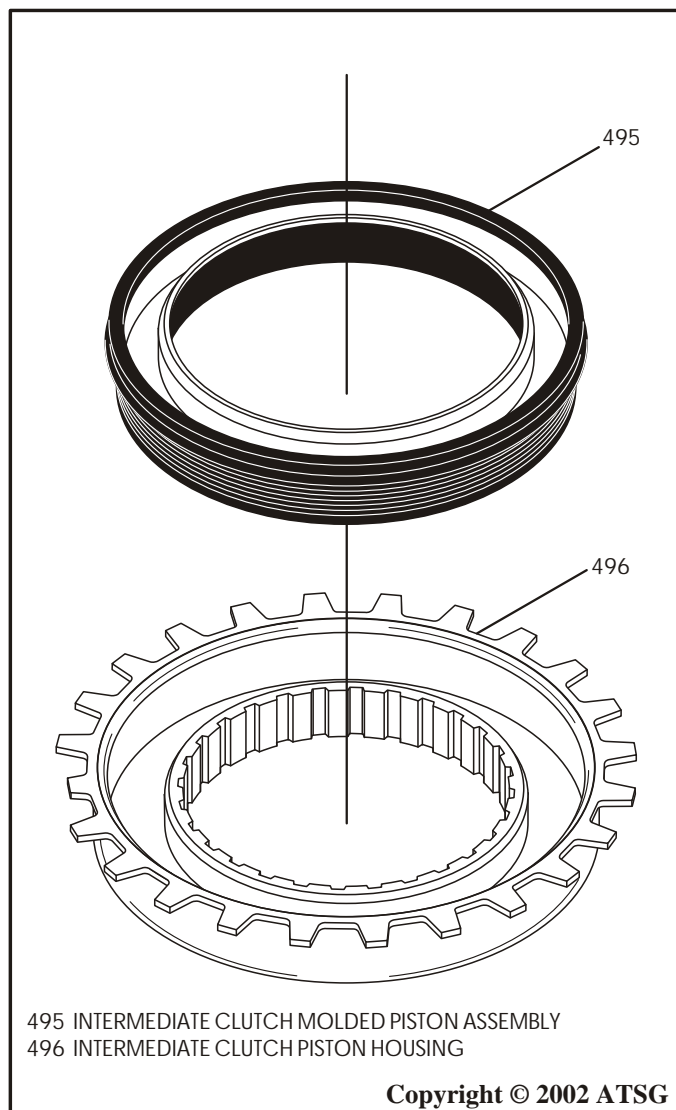

Figure 116

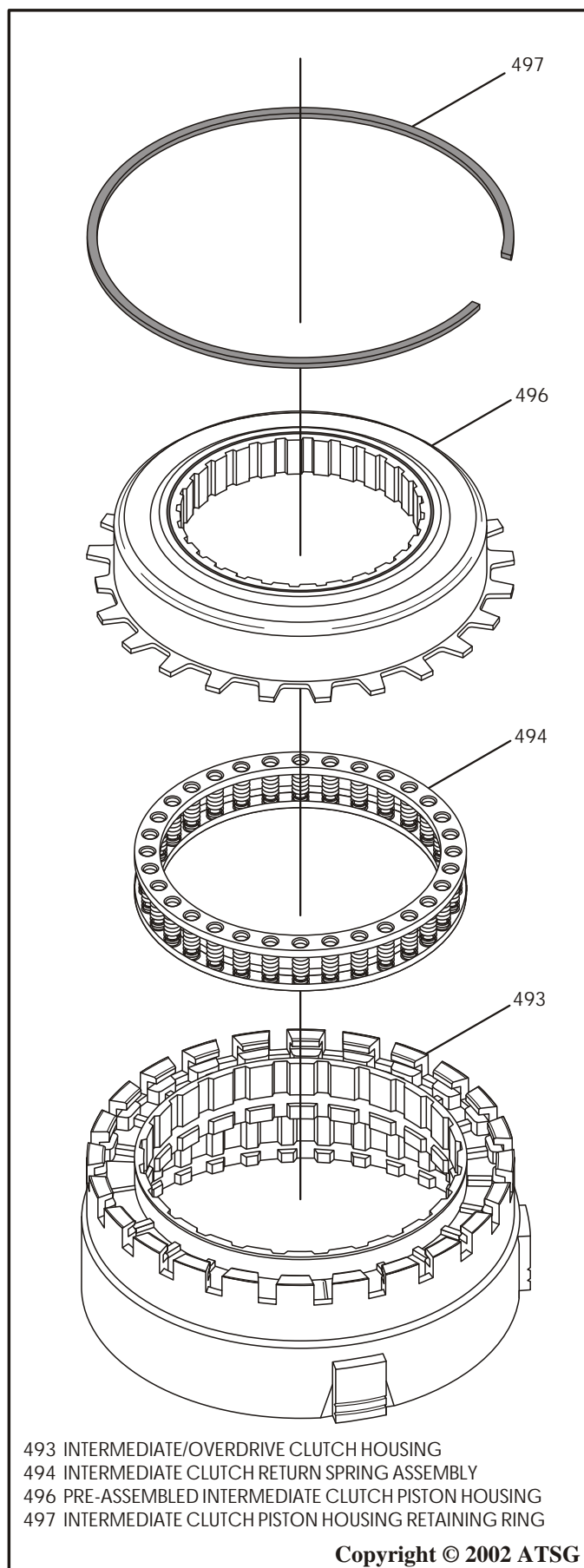

Figure 117



Technical Service Information

5. Install the intermediate clutch return spring assembly into housing, as shown in Figure 117.
6. Install pre-assembled intermediate clutch piston and housing assembly on top of return spring in direction shown in Figure 117.
7. Compress intermediate housing and the return spring using a foot press, and install snap ring, as shown in Figure 117.
8. Turn overdrive housing over and install "Wave" plate, as shown in Figure 118.
9. Install the intermediate clutch "single sided" plates beginning with an outside spline plate first and alternating with inside spline plates until you have installed 3 of each, as shown in Figure 119.

Note: Lined side must be installed facing up as shown in Figure 119. Clutch plate amounts may vary by model.

10. Install the intermediate clutch backing plate, as shown in Figure 119.

Continued on Page 78

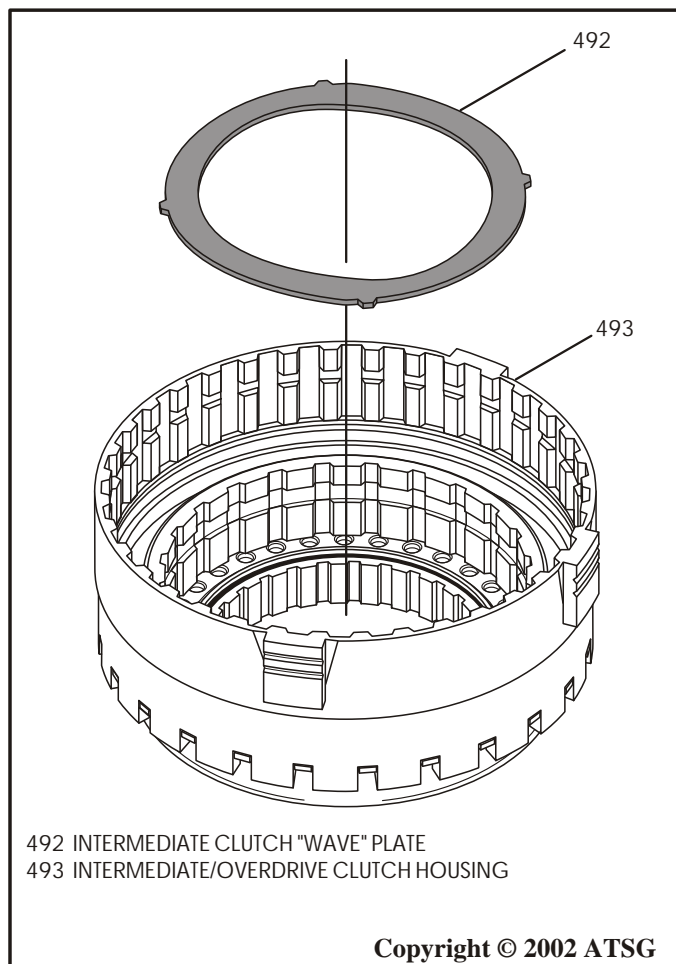

Figure 118

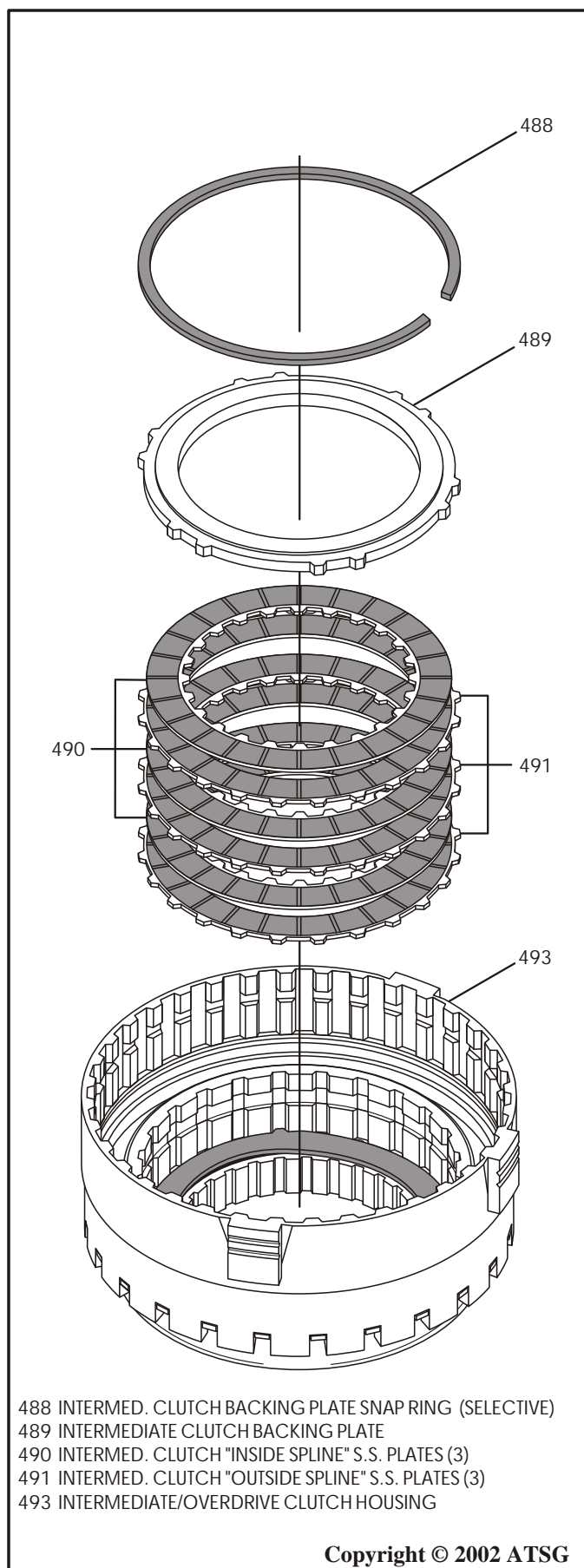

Figure 119



Technical Service Information

COMPONENT REBUILD

O.D. AND INTERMEDIATE CLUTCH HOUSING CONT'D)

11. Install the "Selective" backing plate snap ring as shown in Figure 119, and ensure that snap ring is fully seated against the top of snap ring groove in the housing.
 12. Install dial indicator on top of the intermediate clutch backing plate, as shown in Figure 120, and zero the dial indicator.
 13. Intermediate clutch clearance should be: 0.78 mm (.031") to 1.58 mm (.062"). Change the "Selective" backing plate snap ring as necessary to achieve proper clutch clearance.
 14. Install J-45135 lip seal protector, as shown in Figure 121 to install overdrive clutch piston.
- Note: This tool is mandatory to prevent damage to the O.D. piston seals.**
15. Lubricate molded overdrive clutch piston seals with small amount of Trans-Jel® and install the overdrive clutch piston into the housing, as shown in Figure 122.
 16. Remove the J-45135 lip seal protector.

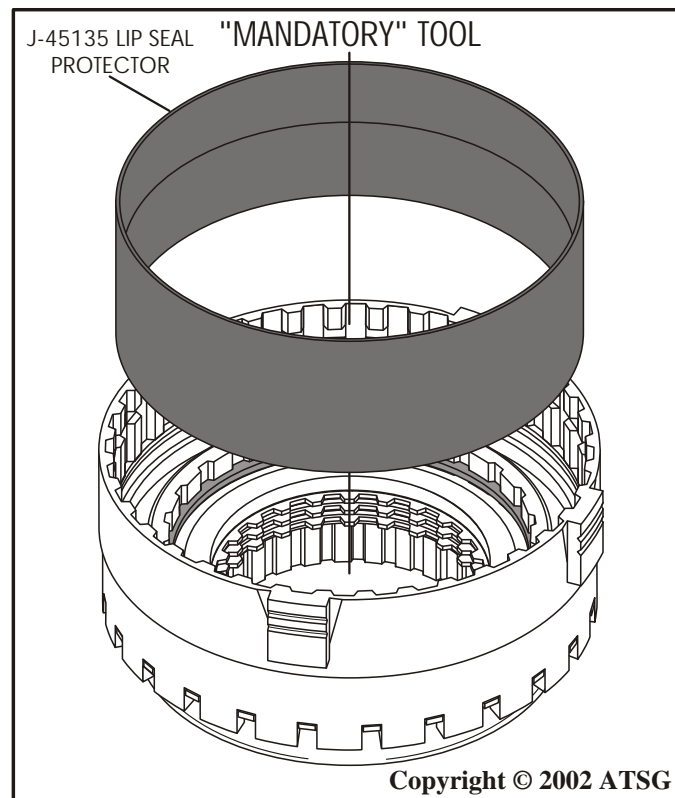

Figure 121

Continued on Page 79

CHECKING INTERMEDIATE CLUTCH CLEARANCE CLEARANCE SHOULD BE .031"-.062"

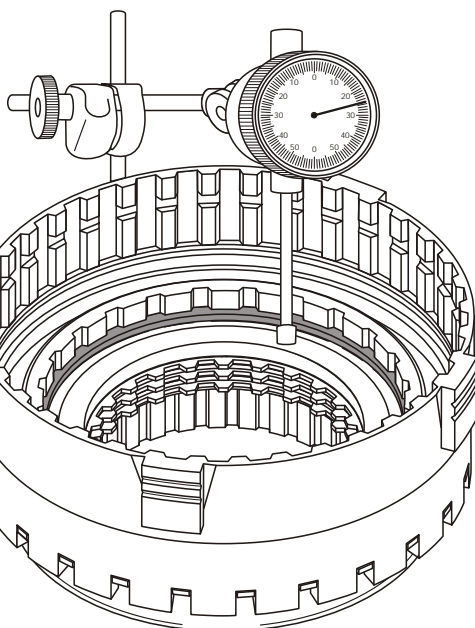

Figure 120

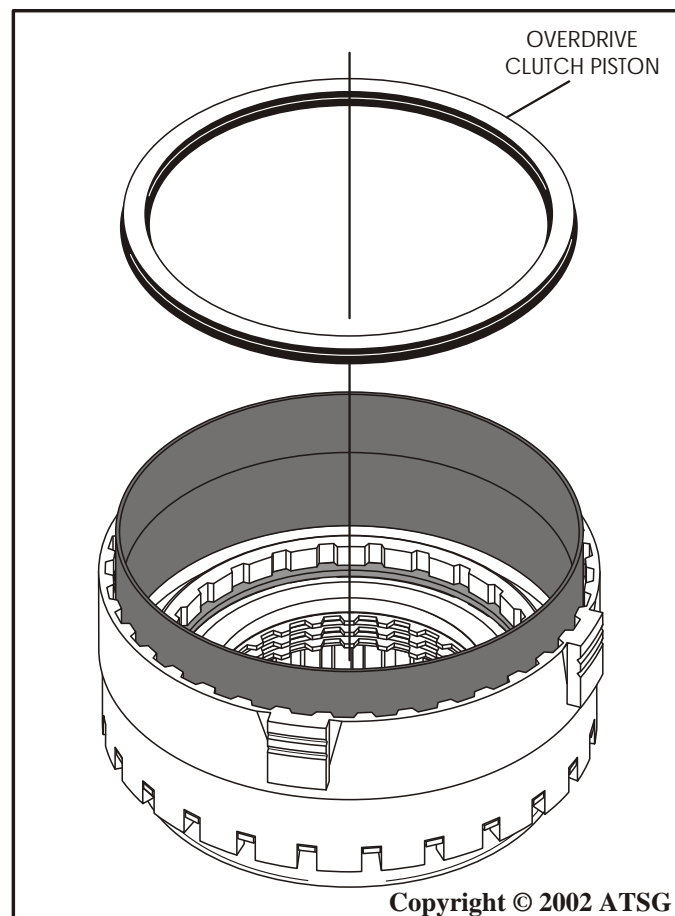

Figure 122

O.D. AND INTERMEDIATE CLUTCH HOUSING (CONT'D)

17. Install the "Bellville" overdrive clutch piston return spring (486), as shown in Figure 123.
18. Using your foot press and J-44764 spring compressor adapter, as shown in Figure 124, compress the return spring and install the snap ring.
19. Install the overdrive clutch apply ring spacer, as shown in Figure 125.

Continued on Page 80

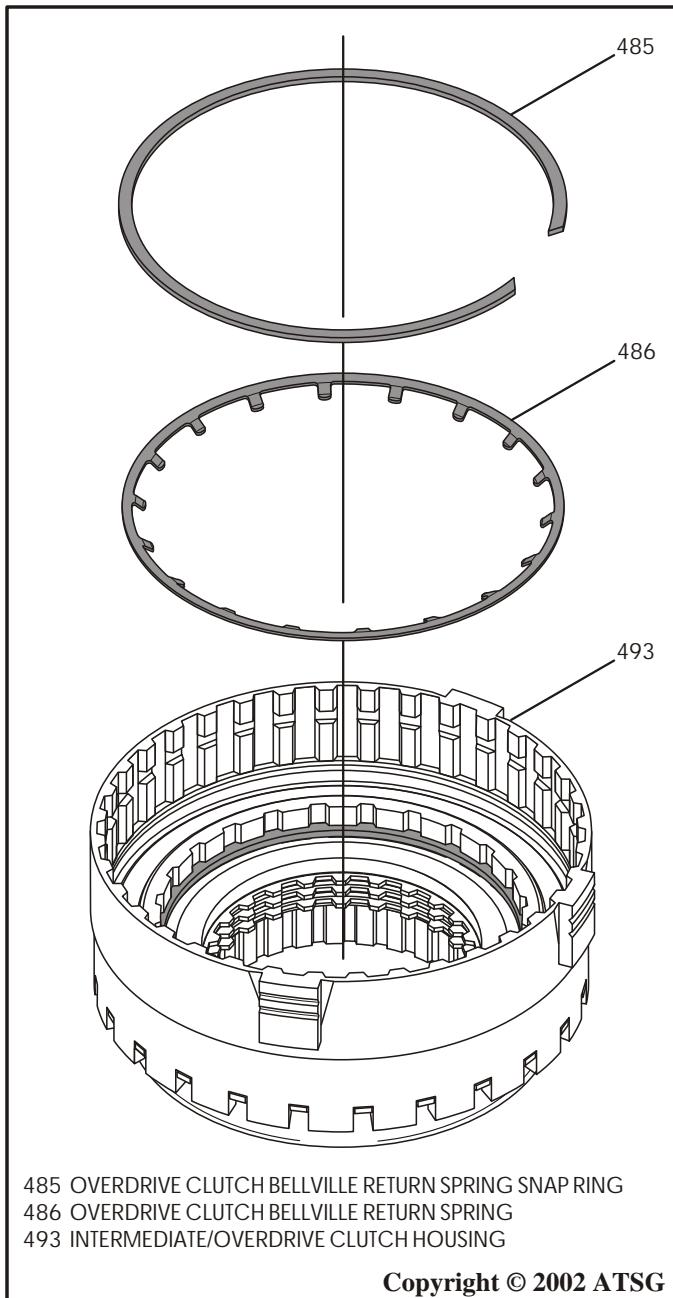

Figure 123

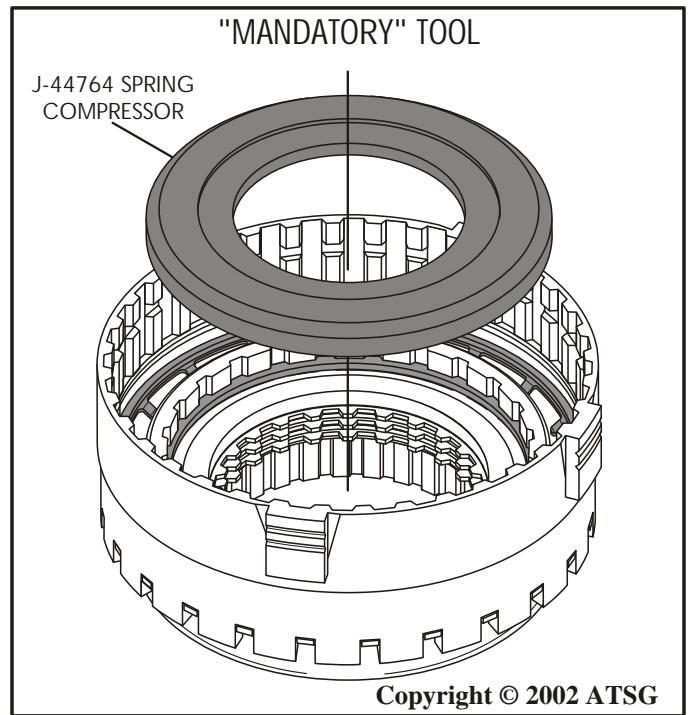

Figure 124

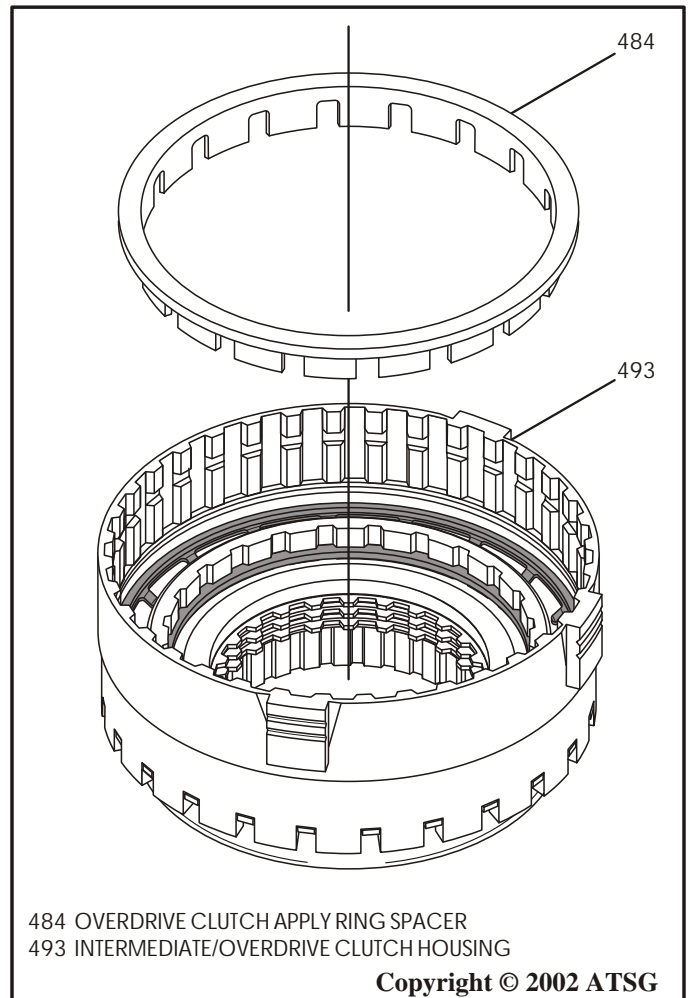

Figure 125



Technical Service Information

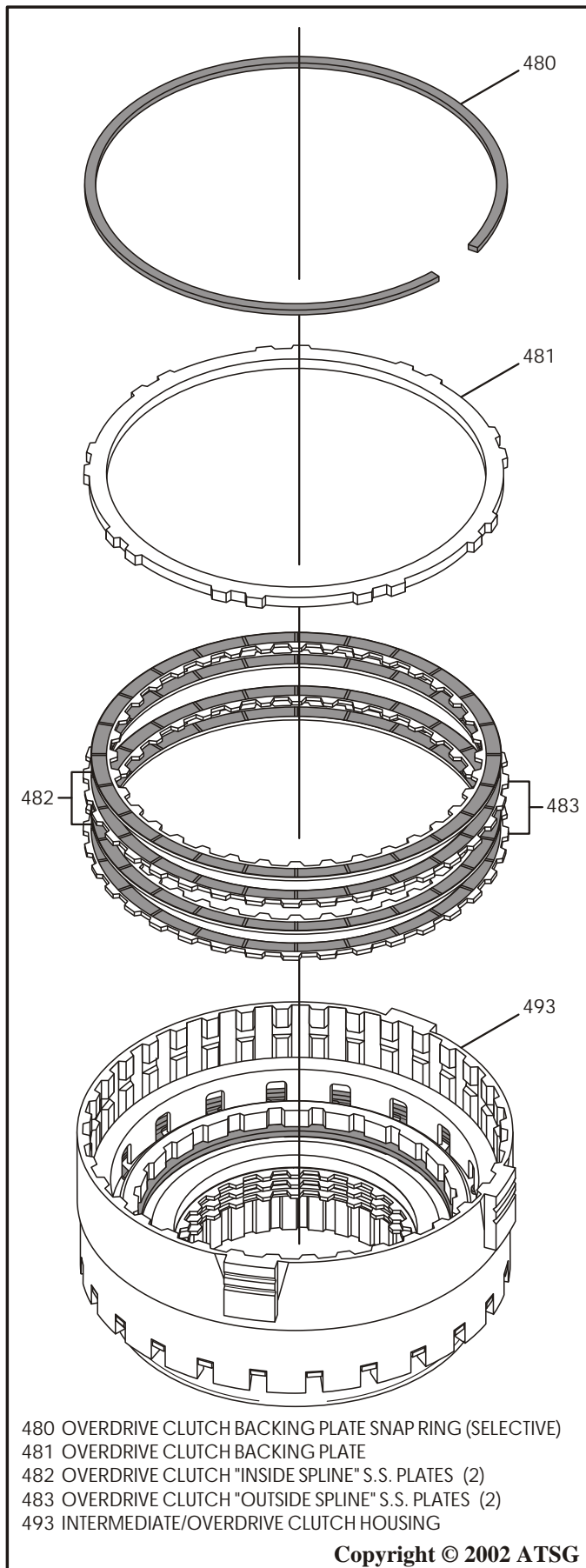

Figure 126

O.D. AND INTERMEDIATE CLUTCH HOUSING (CONT'D)

20. Install the overdrive clutch "single sided" plates beginning with an outside spline plate first and alternating with inside spline plates until you have installed 2 of each (See Figure 126).

Note: *Lined side must be installed facing up as shown in Figure 126. Clutch plate amounts may vary by model.*

21. Install the overdrive clutch backing plate, as shown in Figure 126.

22. Install the "Selective" backing plate snap ring, as shown in Figure 126, and ensure that snap ring is fully seated against the top of snap ring groove in the housing.

23. Install dial indicator on top of the overdrive clutch backing plate, as shown in Figure 127, and zero the dial indicator.

24. Overdrive clutch clearance should be: 0.94 mm (.037") to 1.79 mm (.070"). Change the "Selective" backing plate snap ring as necessary to achieve proper clutch clearance.

25. Set the completed overdrive clutch housing aside for transmission final assembly process.

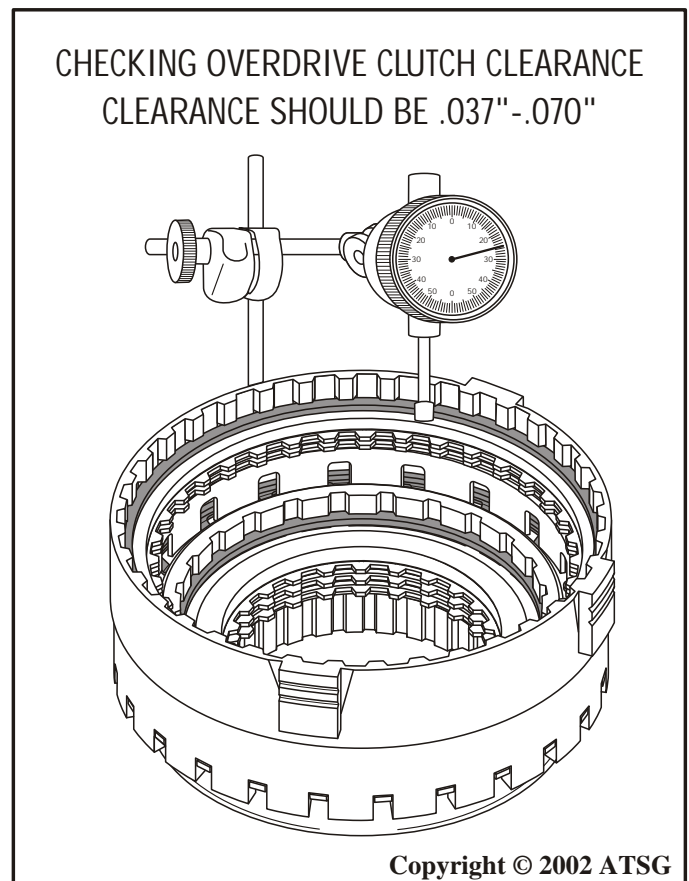

Figure 127



Technical Service Information

COMPONENT REBUILD

LOW SPRAG ASSEMBLY

1. Inspect the low sprag assembly for proper hold and freewheel operation (See Figure 128).
2. Inspect the low sprag assembly for any visible wear and/or damage, and then set aside for the transmission final assembly process.
3. If replacement is necessary, low sprag must be serviced as a complete assembly.

"SPECIAL NOTE"

LOW SPRAG CANNOT BE DIS-ASSEMBLED
IF SERVICE IS NECESSARY, IT MUST BE
REPLACED AS A SERVICE PACKAGE.
EXPLODED VIEW IS FOR REFERENCE ONLY!

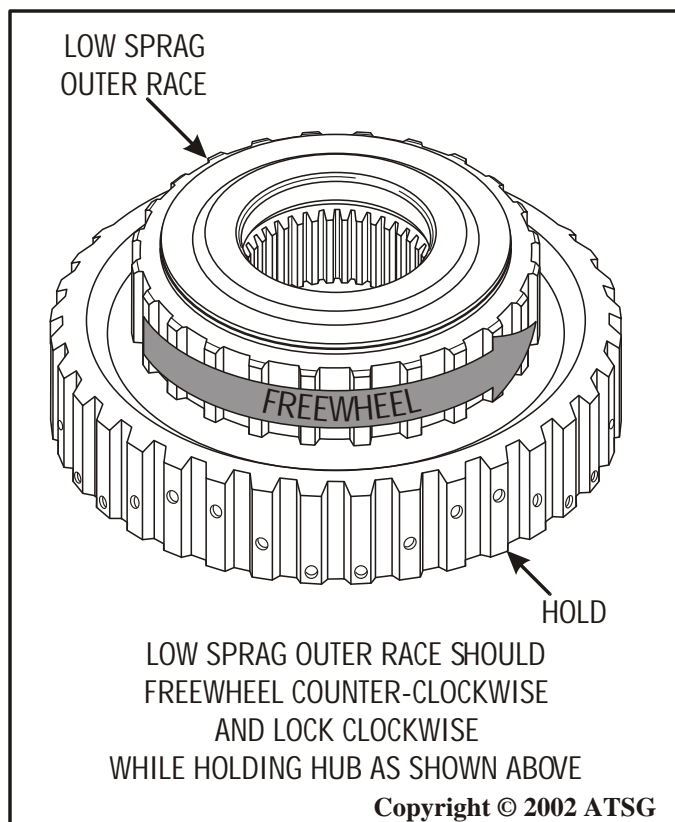

Figure 128

Serviced As Complete Assembly

- 500 LOW SPRAG ASSEMBLY RETAINER (CRIMPED IN PLACE)
- 501 LOW SPRAG THRUST WASHER (2)
- 502 LOW SPRAG END BEARINGS (2)
- 503 LOW SPRAG AND CAGE ASSEMBLY
- 504 LOW SPRAG OUTER RACE
- 505 LOW SPRAG INNER RACE

Figure 129 legend

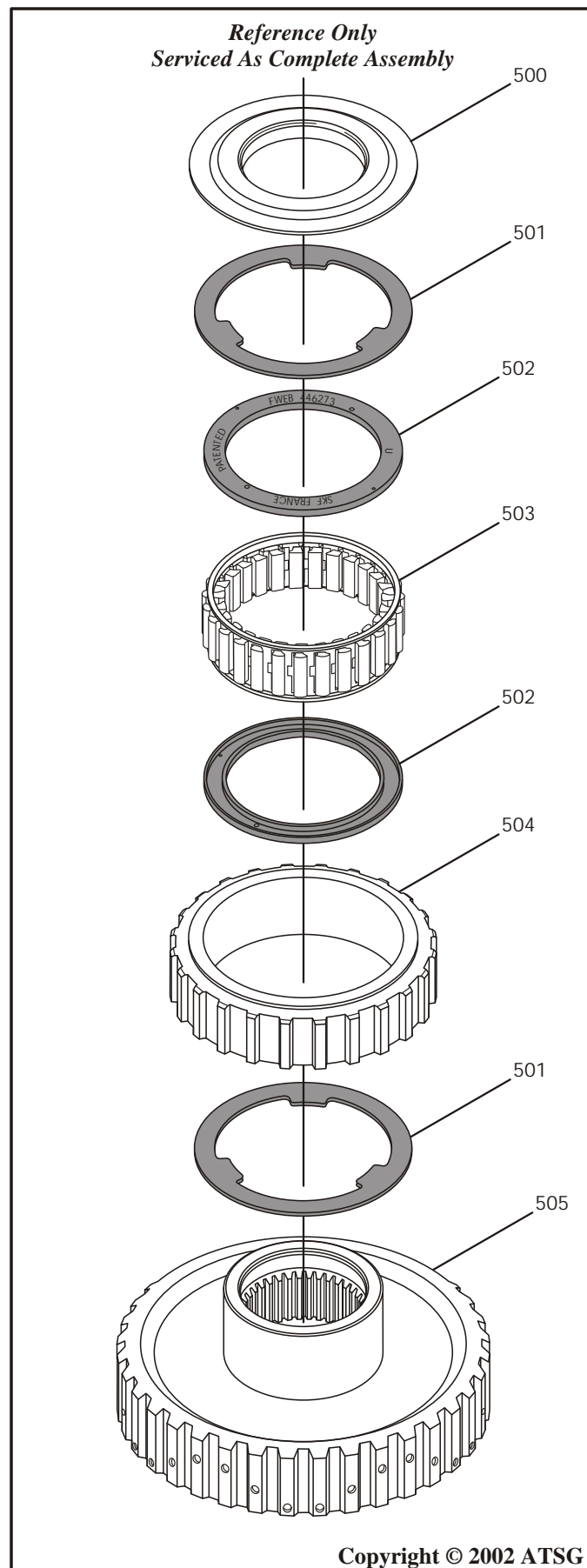
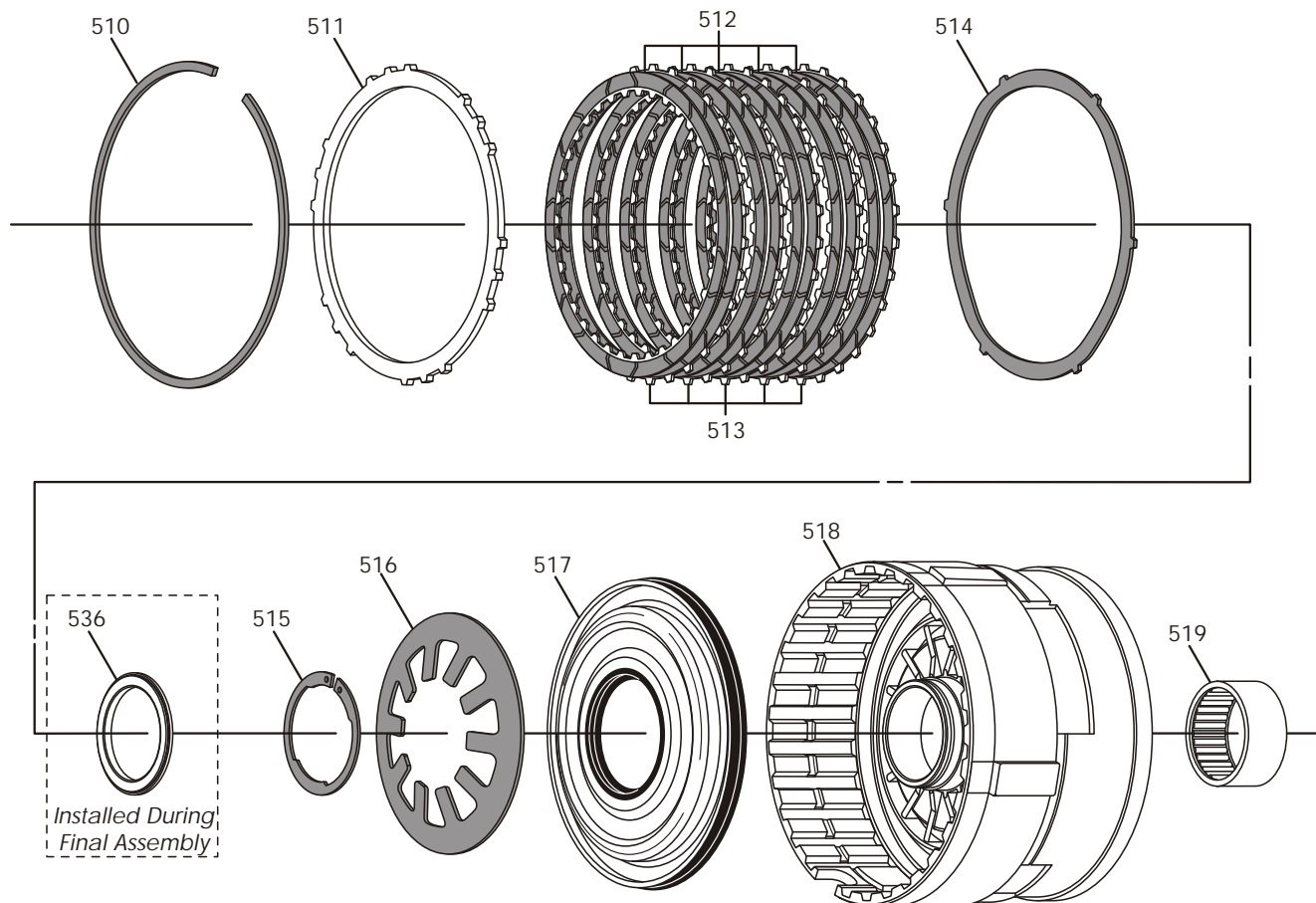

Figure 129



Technical Service Information

CENTER SUPPORT "FRONT SIDE" EXPLODED VIEW



- 510 LOW/REVERSE CLUTCH BACKING PLATE SNAP RING (SELECTIVE)
- 511 LOW/REVERSE CLUTCH BACKING PLATE
- 512 LOW/REVERSE CLUTCH "INNER SPLINE" SINGLE SIDED PLATE (5)
- 513 LOW/REVERSE CLUTCH "OUTER SPLINE" SINGLE SIDED PLATE (5)
- 514 LOW/REVERSE CLUTCH "WAVE" PLATE
- 515 LOW/REVERSE CLUTCH BELLVILLE RETURN PLATE SNAP RING
- 516 LOW/REVERSE CLUTCH BELLVILLE RETURN SPRING
- 517 LOW/REVERSE CLUTCH PISTON ASSEMBLY
- 518 CENTER SUPPORT ASSEMBLY
- 519 CAGED NEEDLE BEARING ASSEMBLY
- 520 2ND CLUTCH PISTON ASSEMBLY
- 521 2ND CLUTCH PISTON RETURN SPRING ASSEMBLY
- 522 2ND CLUTCH RETURN SPRING RETAINER SNAP RING
- 523 2ND CLUTCH "WAVE" PLATE

- 524 2ND CLUTCH "OUTER SPLINE" SINGLE SIDED PLATE (5)
- 525 2ND CLUTCH "INNER SPLINE" SINGLE SIDED PLATE (5)
- 526 2ND CLUTCH BACKING PLATE
- 527 2ND CLUTCH BACKING PLATE SNAP RING (SELECTIVE)
- 528 2ND COAST CLUTCH PISTON ASSEMBLY
- 529 2ND COAST CLUTCH PISTON BELLVILLE RETURN SPRING
- 530 2ND COAST CLUTCH BELLVILLE RETURN SPRING SNAP RING
- 531 2ND COAST CLUTCH APPLY/SPACER RING
- 532 2ND COAST CLUTCH "OUTER SPLINE" SINGLE SIDED PLATE (3)
- 533 2ND COAST CLUTCH "INNER SPLINE" SINGLE SIDED PLATE (3)
- 534 2ND COAST CLUTCH BACKING PLATE
- 535 2ND COAST CLUTCH BACKING PLATE SNAP RING (SELECTIVE)
- 536 LOW SPRAG TO CENTER SUPPORT THRUST BEARING
- 537 2ND CLUTCH PISTON RETURN SPRING RETAINER

Copyright © 2002 ATSG

Figure 130



Technical Service Information

CENTER SUPPORT "REAR SIDE" EXPLODED VIEW

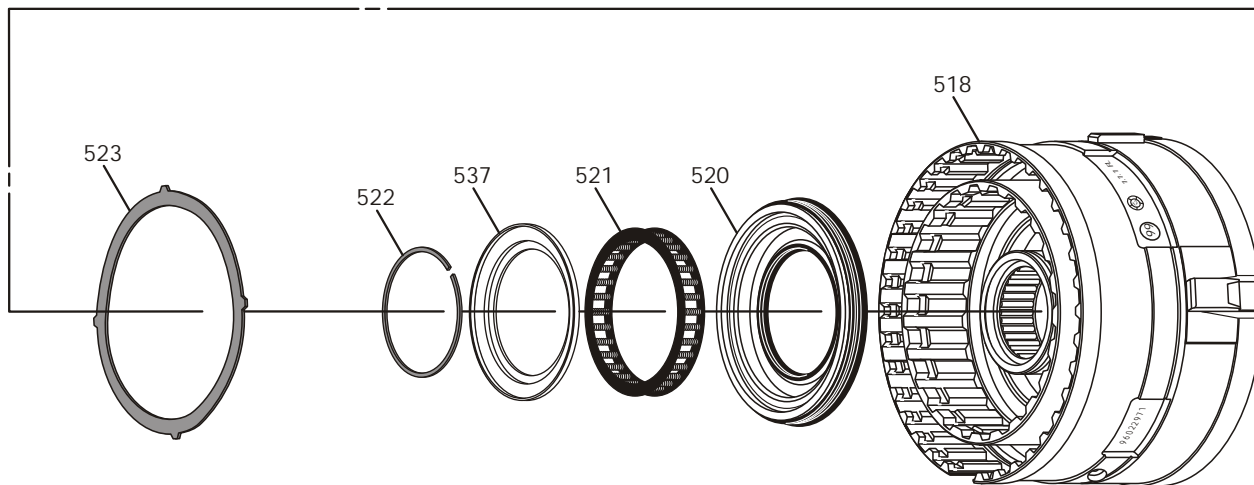
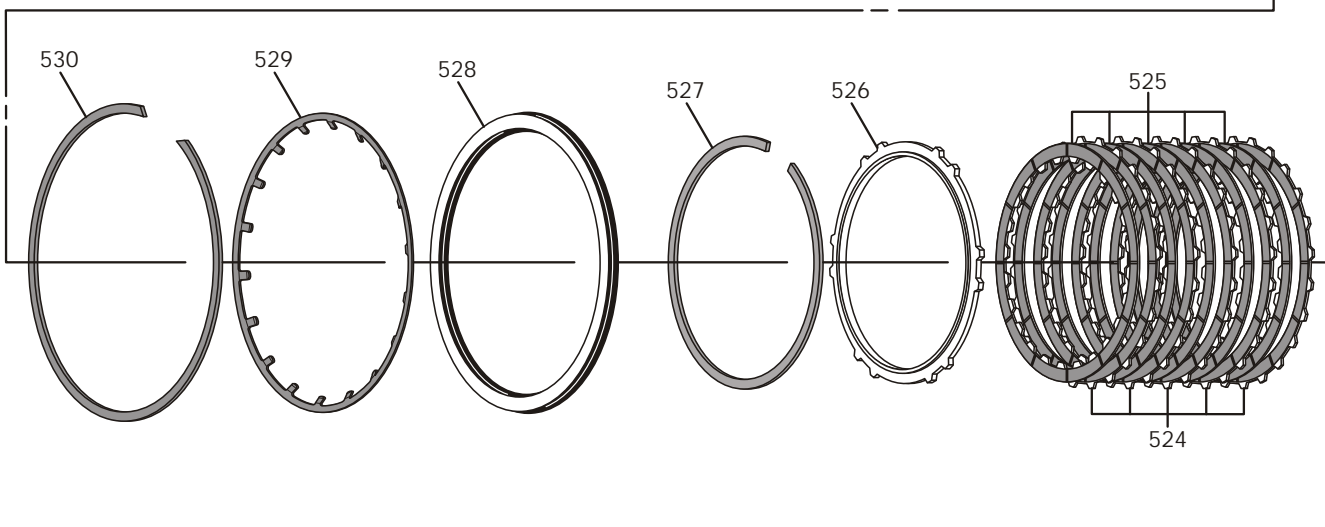
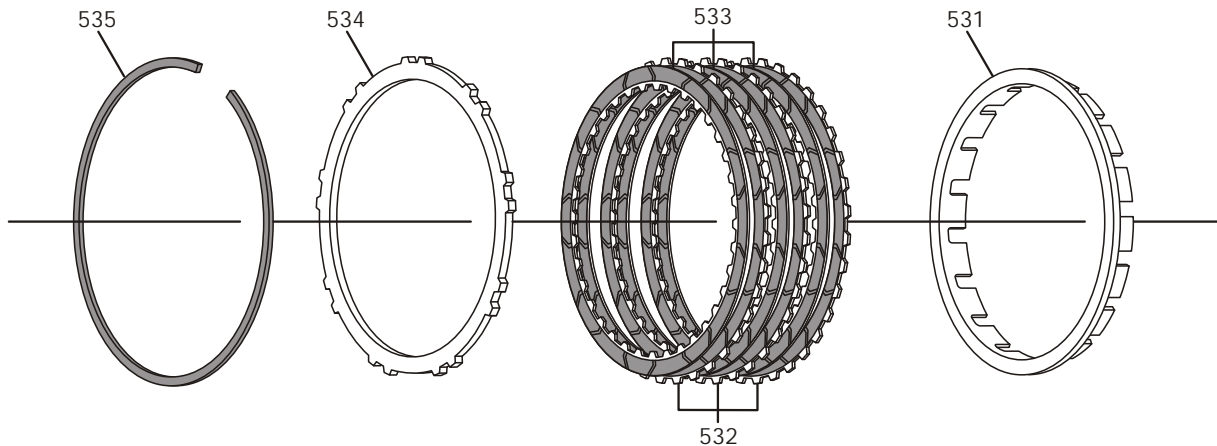

Legend For This Illustration Is Found In Figure 130

Copyright © 2002 ATSG

Figure 131



Technical Service Information

COMPONENT REBUILD

CENTER SUPPORT

1. Dis-assemble the center support using Figures 130 and 131 as a guide.
2. Clean all center support parts thoroughly and dry with compressed air.
3. Inspect all center support parts thoroughly for the following:
 - o Plugged feed passages
 - o Damaged or worn splines
 - o Damaged or worn springs
 - o Damaged or worn pistons
 - o Damaged or worn clutch plates
4. Replace the caged needle bearing as necessary, using the proper puller and proper diameter installer (See Figure 132).
5. Install J-45136 and J-45140 lip seal protectors, as shown in Figure 133, on low/reverse side.

Note: These tools are mandatory to prevent damage to the L/R piston seals.

6. Lubricate the low/reverse clutch piston seals with small amount of Trans-Jel® and install the low/reverse clutch piston in the center support, as shown in Figure 134.
7. Remove the lip seal protectors.
8. Install the low/reverse clutch "Bellville" return spring, as shown in Figure 134.

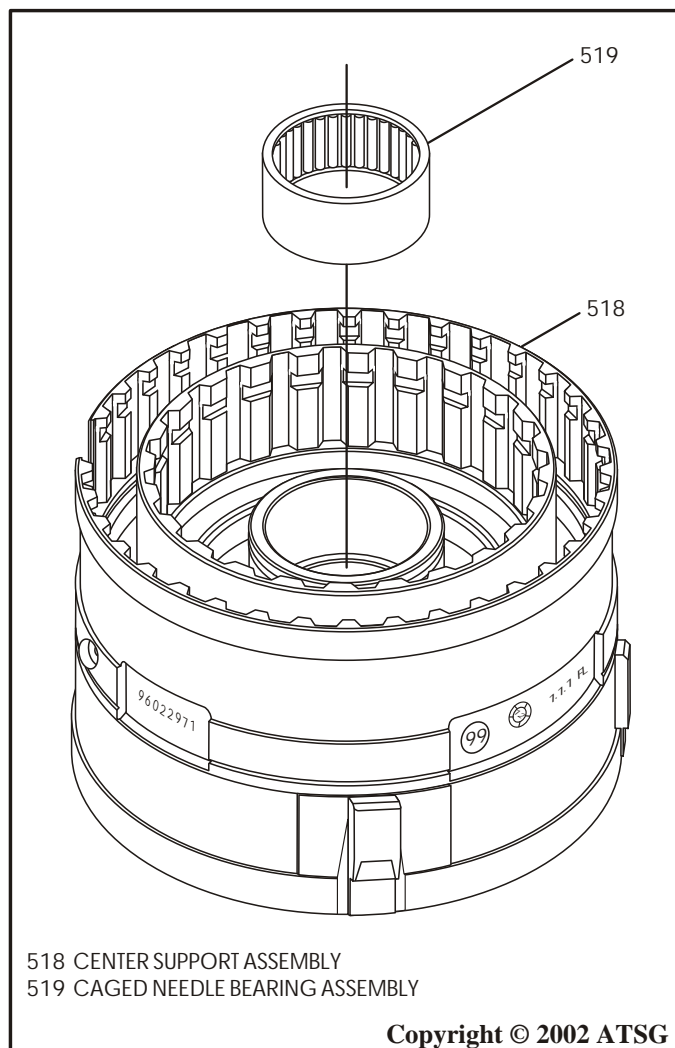

Figure 132

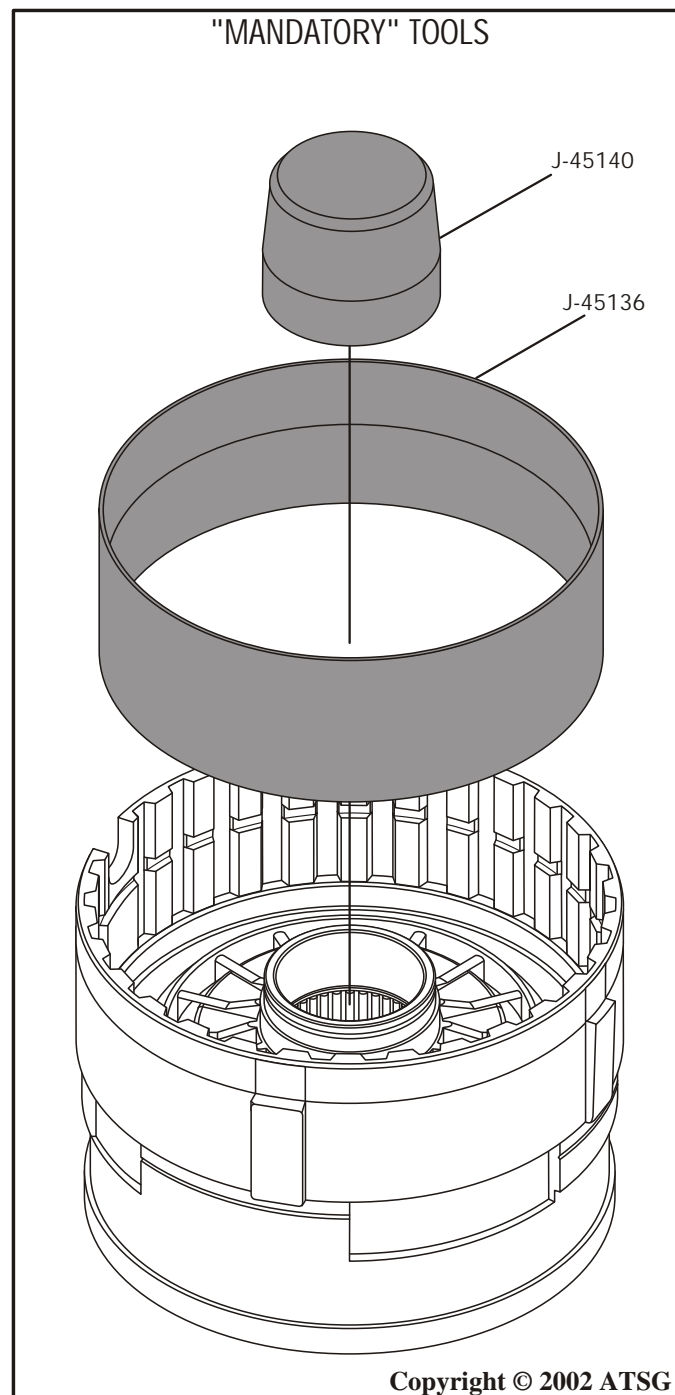

Figure 133



Technical Service Information

9. Place the assembly on foot press, compress the return spring and install the retaining snap ring (See Figure 134).
10. Install the low/reverse clutch "Wave" plate into center support, as shown in Figure 135.

Continued on Page 86

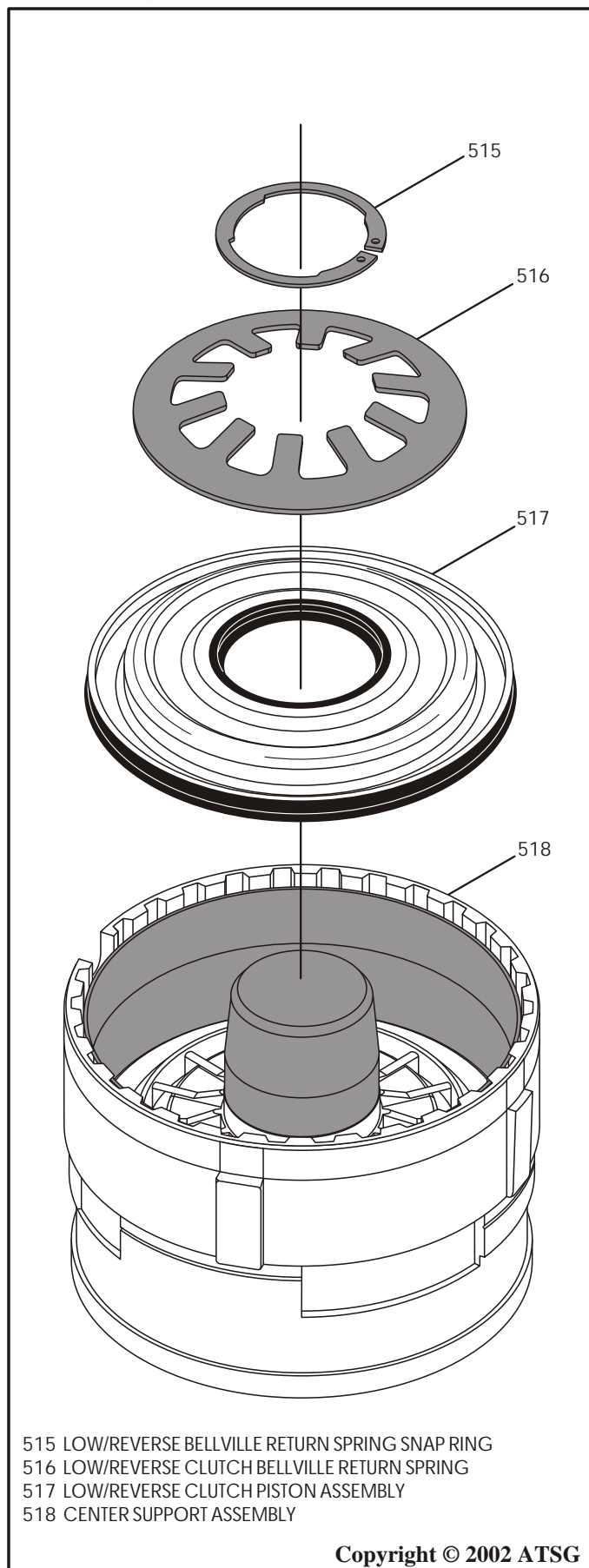

Figure 134

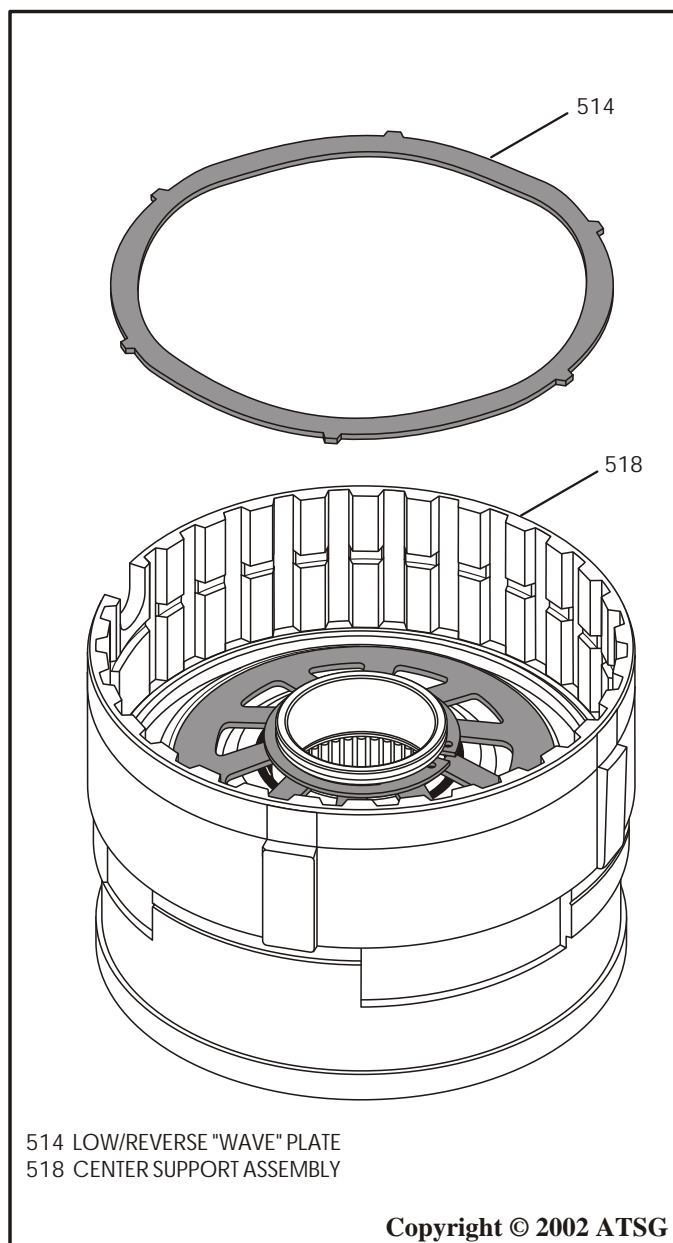

Figure 135



Technical Service Information

CENTER SUPPORT (CONT'D)

11. Install low/reverse clutch "single sided" plates beginning with an outside spline plate first and alternating with inside spline plates until you have installed 5 of each (See Figure 136).

Note: *Lined side must be installed facing up, as shown in Figure 136. Clutch plate amounts may vary by model.*

12. Install the low/reverse backing plate, as shown in Figure 137.

13. Install the "Selective" backing plate snap ring, as shown in Figure 137, and ensure that snap ring is fully seated against the top of snap ring groove in the center support.

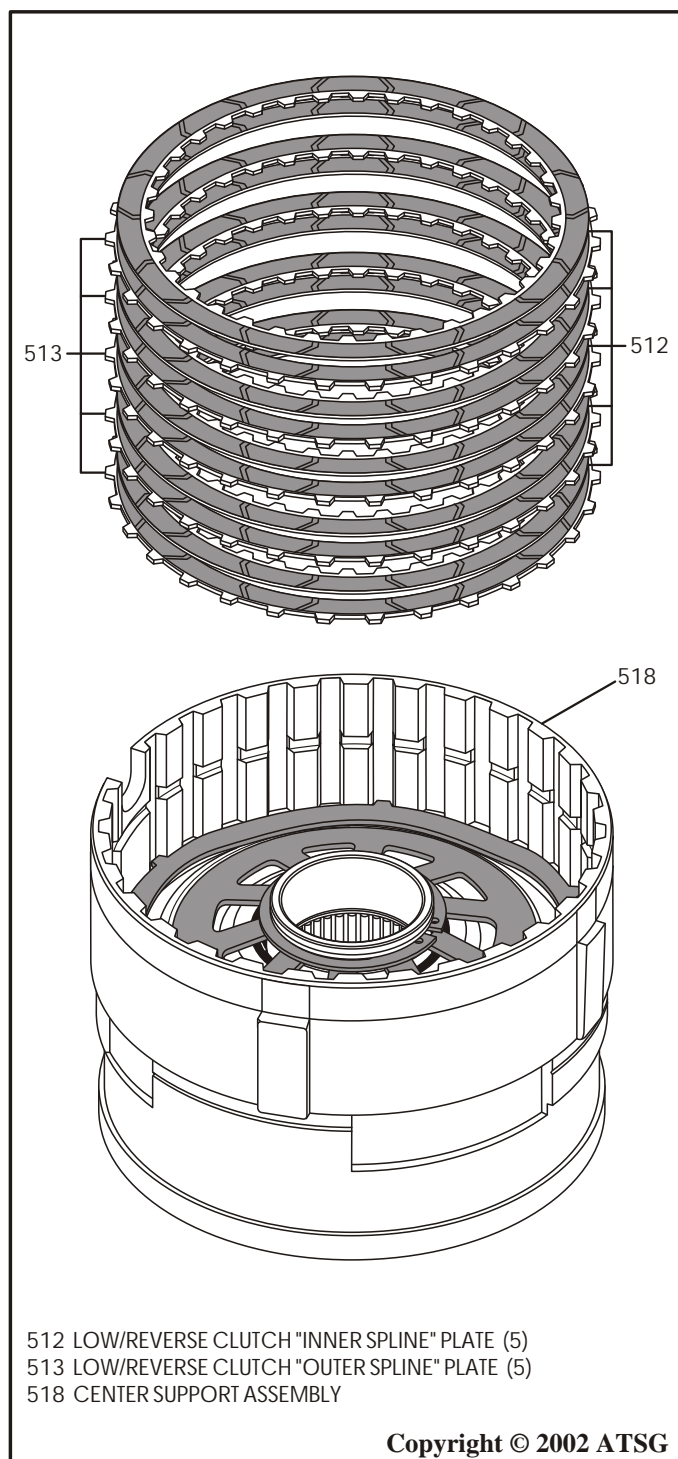

Figure 136

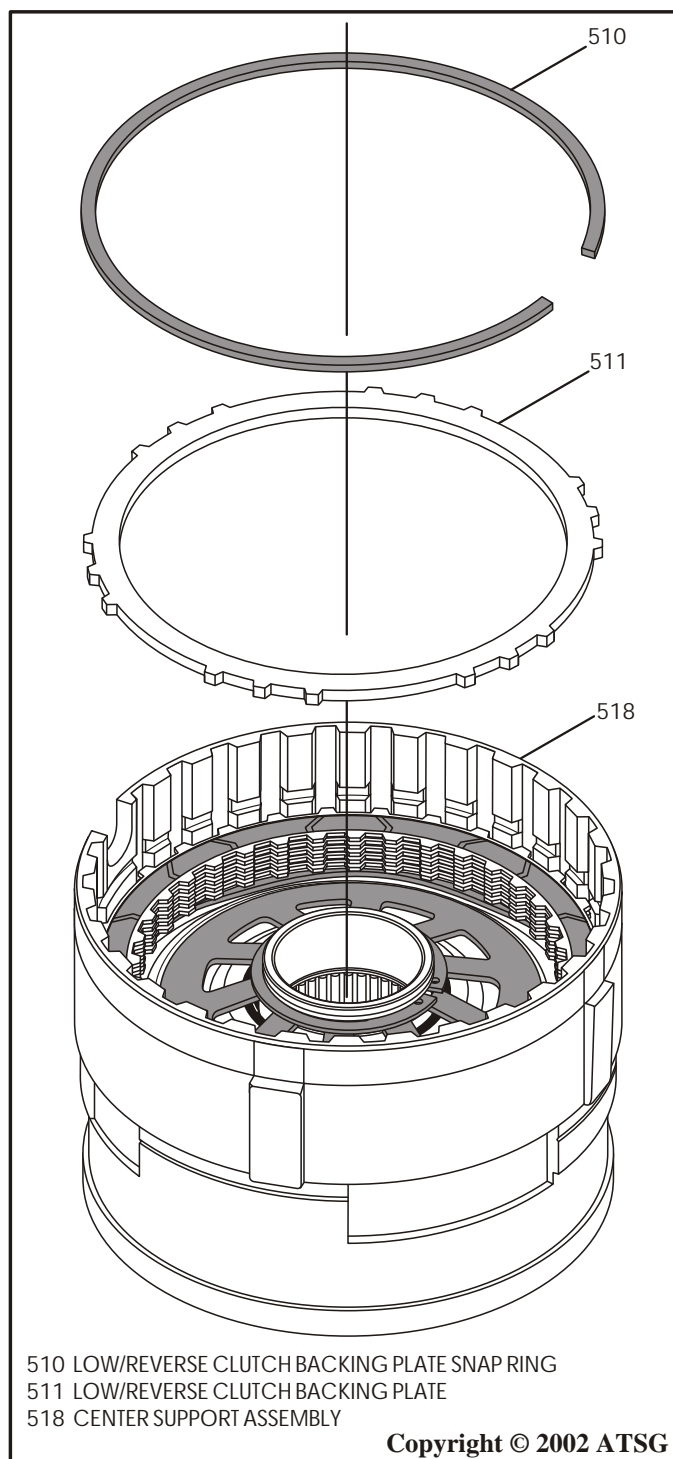

Figure 137



Technical Service Information

14. Install dial indicator on top of the low/reverse clutch backing plate, as shown in Figure 138, and zero the dial indicator.
15. Low/Reverse clutch clearance should be: 1.32 mm (.052") to 2.17 mm (.085"). Change the "Selective" backing plate snap ring as necessary to achieve proper clutch clearance.
16. Turn the center support over, install J-45137 and J-45145 lip seal protectors, as shown in Figure 139.

Note: *These tools are mandatory to prevent damage to the 2nd clutch piston seals.*

Continued on Page 88

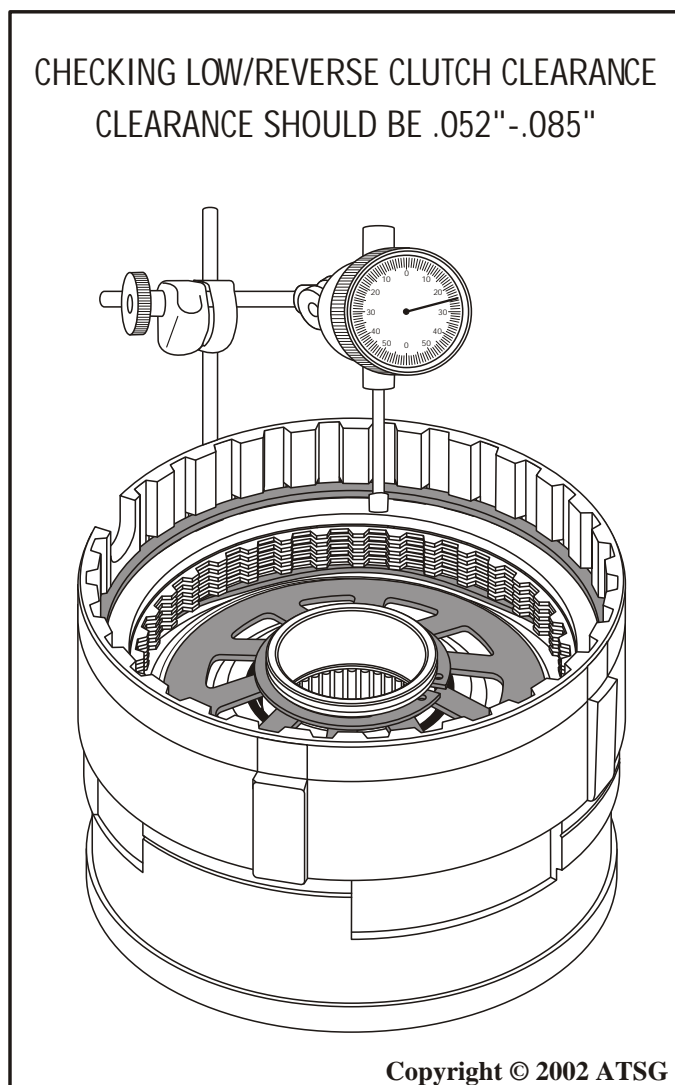

Figure 138

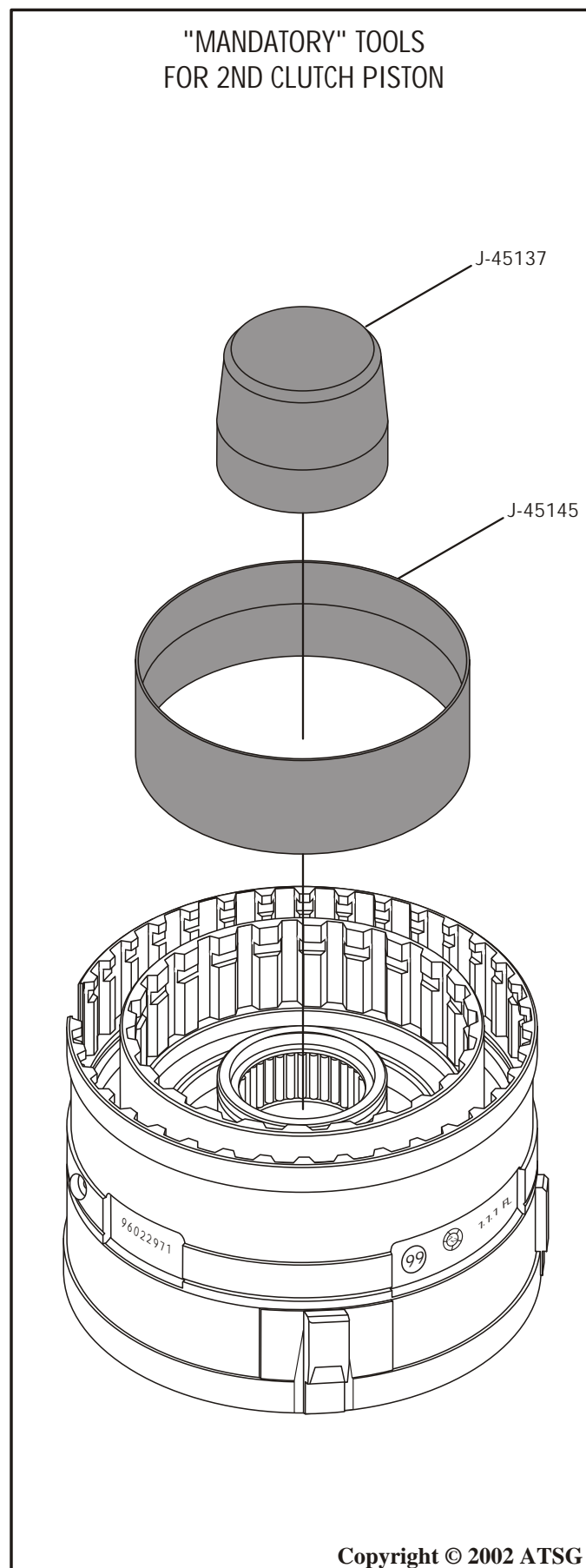

Figure 139



Technical Service Information

CENTER SUPPORT (CONT'D)

17. Lubricate the 2nd clutch piston seals with a small amount of Trans-Jel® and install the 2nd clutch piston into the center support, as shown in Figure 140.
18. Remove the lip seal protectors.
19. Install the 2nd clutch return spring assembly, as shown in Figure 140.
20. Install the return spring retainer and snap ring on top of the return spring (See Figure 140).
21. Place center support on foot press, compress return spring and retainer, and install the snap ring ensuring that it is fully seated.
22. Install the 2nd clutch "Wave" plate into center support, as shown in Figure 141.
23. Install the 2nd clutch "single sided" plates beginning with an outside spline plate first and alternating with inside spline plates until you have installed 5 of each (See Figure 141).
Note: Lined side must be installed facing up, as shown in Figure 141. Clutch plate amounts may vary by model. This set of clutch plates are not used at all in the "4L40-E" models.
24. Install the 2nd clutch backing plate, as shown in Figure 142.
25. Install the "Selective" backing plate snap ring, as shown in Figure 141, and ensure that snap ring is fully seated against the top of snap ring groove in the center support.

Continued on Page 90

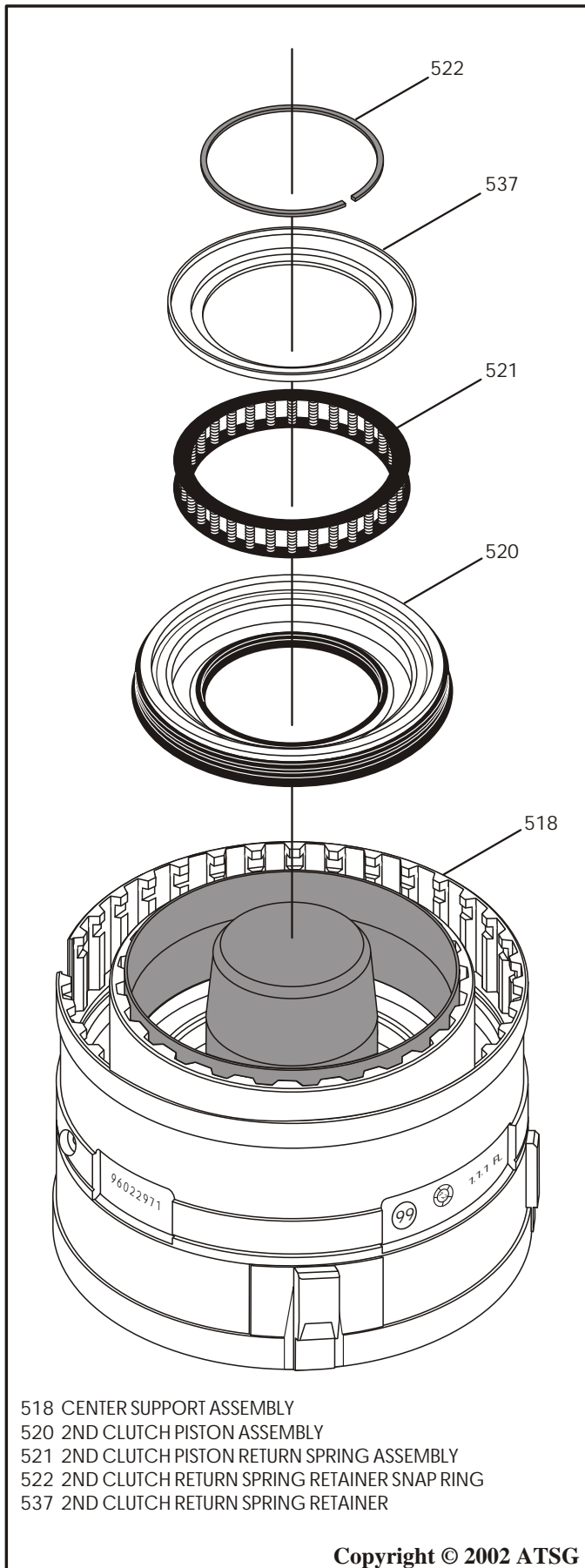

518 CENTER SUPPORT ASSEMBLY
 520 2ND CLUTCH PISTON ASSEMBLY
 521 2ND CLUTCH PISTON RETURN SPRING ASSEMBLY
 522 2ND CLUTCH RETURN SPRING RETAINER SNAP RING
 537 2ND CLUTCH RETURN SPRING RETAINER

Copyright © 2002 ATSG

Figure 140



Technical Service Information

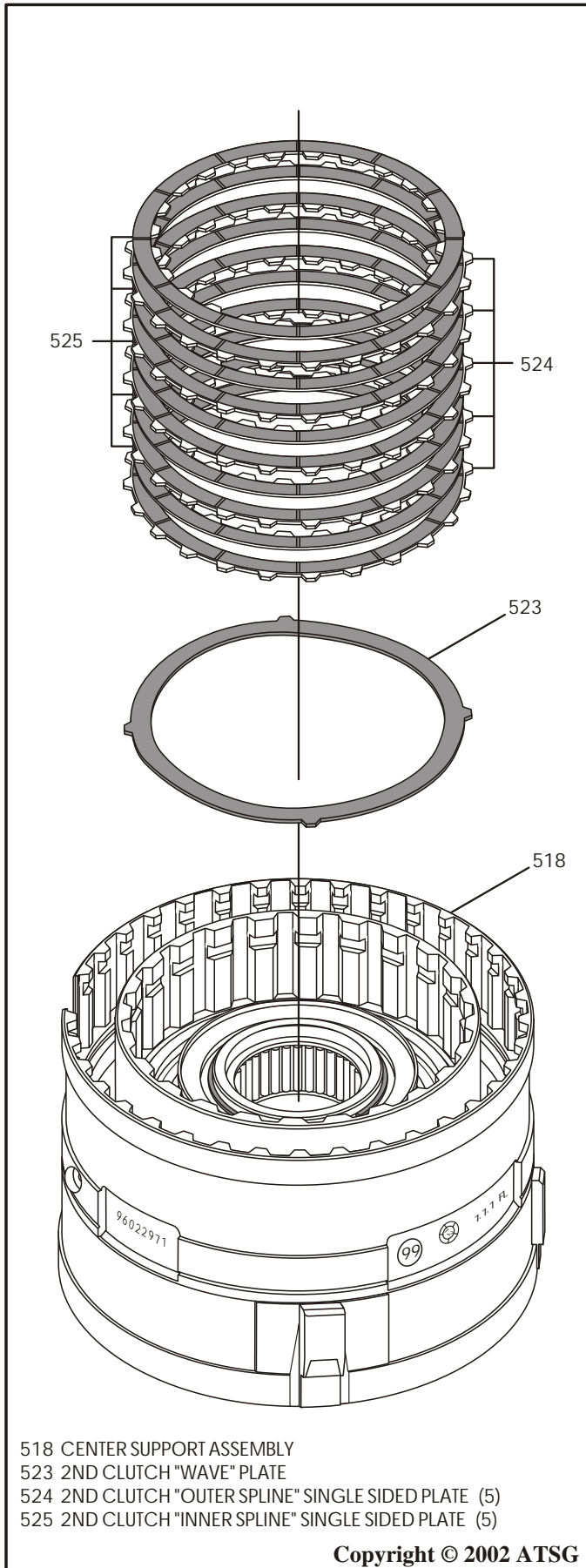

- 518 CENTER SUPPORT ASSEMBLY
- 523 2ND CLUTCH "WAVE" PLATE
- 524 2ND CLUTCH "OUTER SPLINE" SINGLE SIDED PLATE (5)
- 525 2ND CLUTCH "INNER SPLINE" SINGLE SIDED PLATE (5)

Copyright © 2002 ATSG

Figure 141

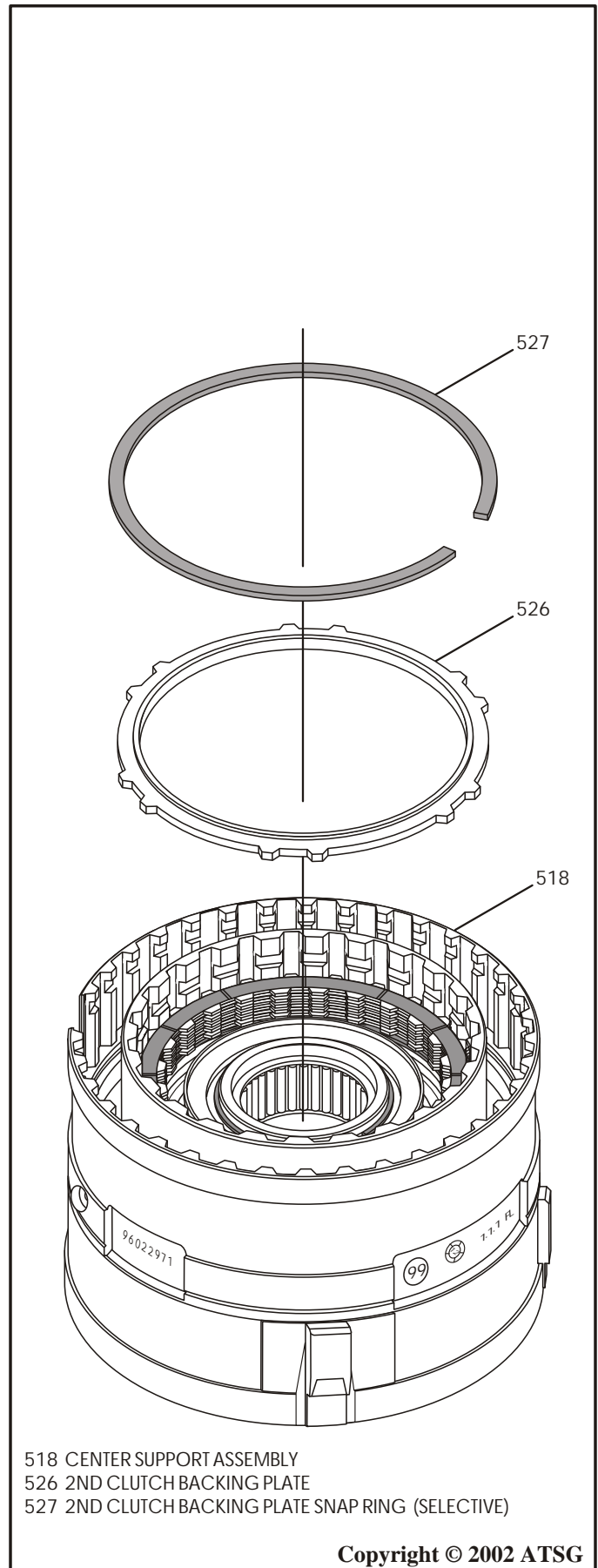

- 518 CENTER SUPPORT ASSEMBLY
- 526 2ND CLUTCH BACKING PLATE
- 527 2ND CLUTCH BACKING PLATE SNAP RING (SELECTIVE)

Copyright © 2002 ATSG

Figure 142



Technical Service Information

CENTER SUPPORT (CONT'D)

26. Install dial indicator on top of the 2nd clutch backing plate, as shown in Figure 143, and zero the dial indicator.
 27. 2nd Clutch clearance should be: 1.32 mm (.052") to 1.92 mm (.076"). Change the "Selective" backing plate snap ring as necessary to achieve proper clutch clearance.
 28. Install J-45136 lip seal protector, as shown in Figure 144.
- Note: This is a mandatory tool to prevent any damage to 2nd coast clutch piston seals.**
29. Lubricate the 2nd coast clutch piston seals with small amount of Trans-Jel® and install the 2nd coast clutch piston into the center support using the J-45145 installation tool (See Figure 145).

30. Remove the J-45136 lip seal protector.
31. Install the 2nd coast clutch "Bellville" return spring, as shown in Figure 146.
32. Compress return spring and install the return spring snap ring as shown in Figure 146.

Continued on Page 93

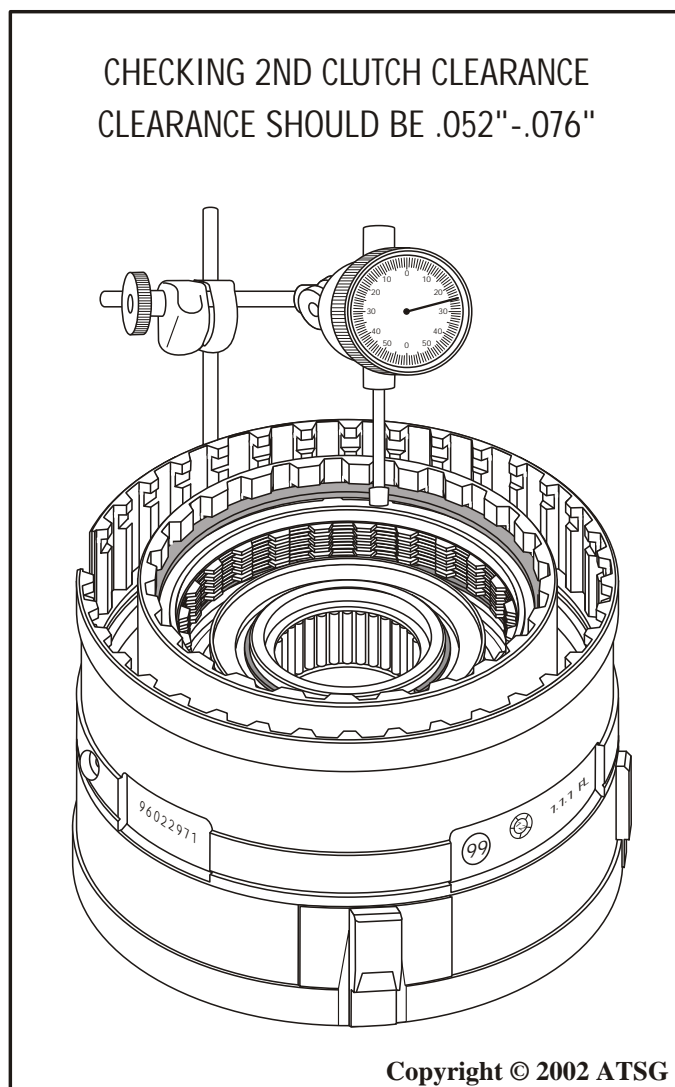

Figure 143

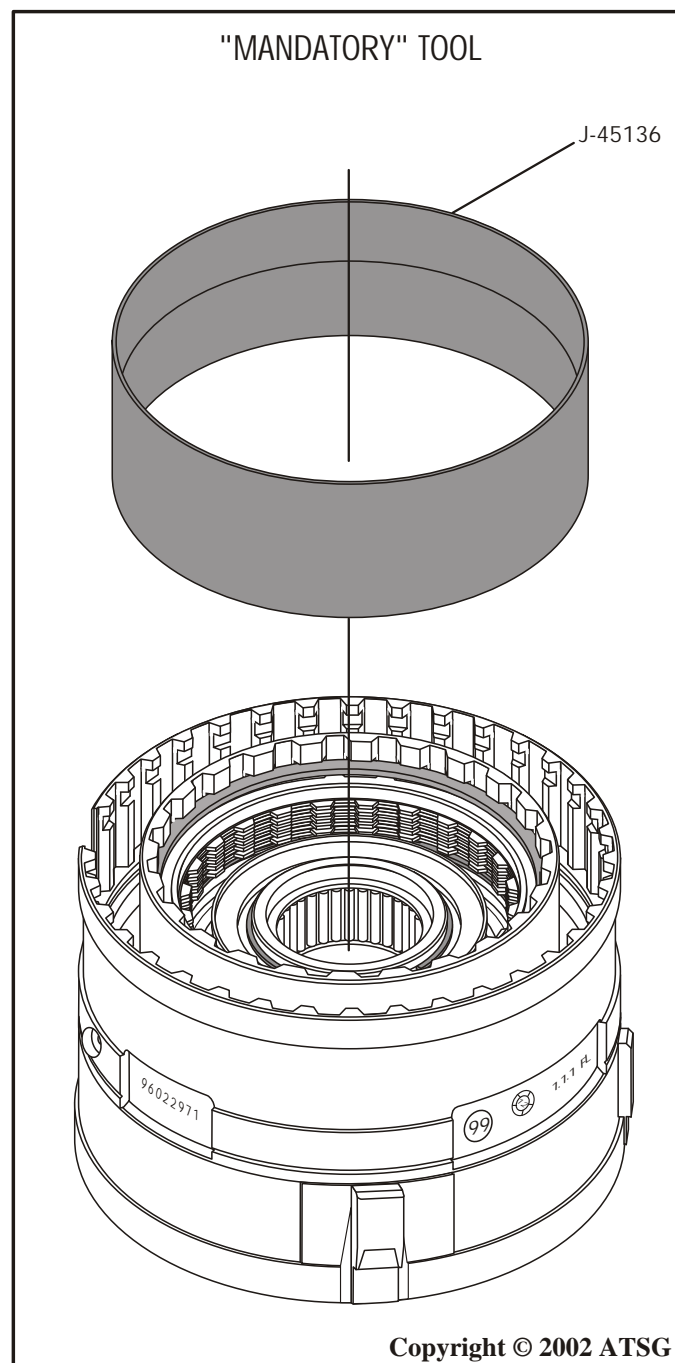

Figure 144



Technical Service Information

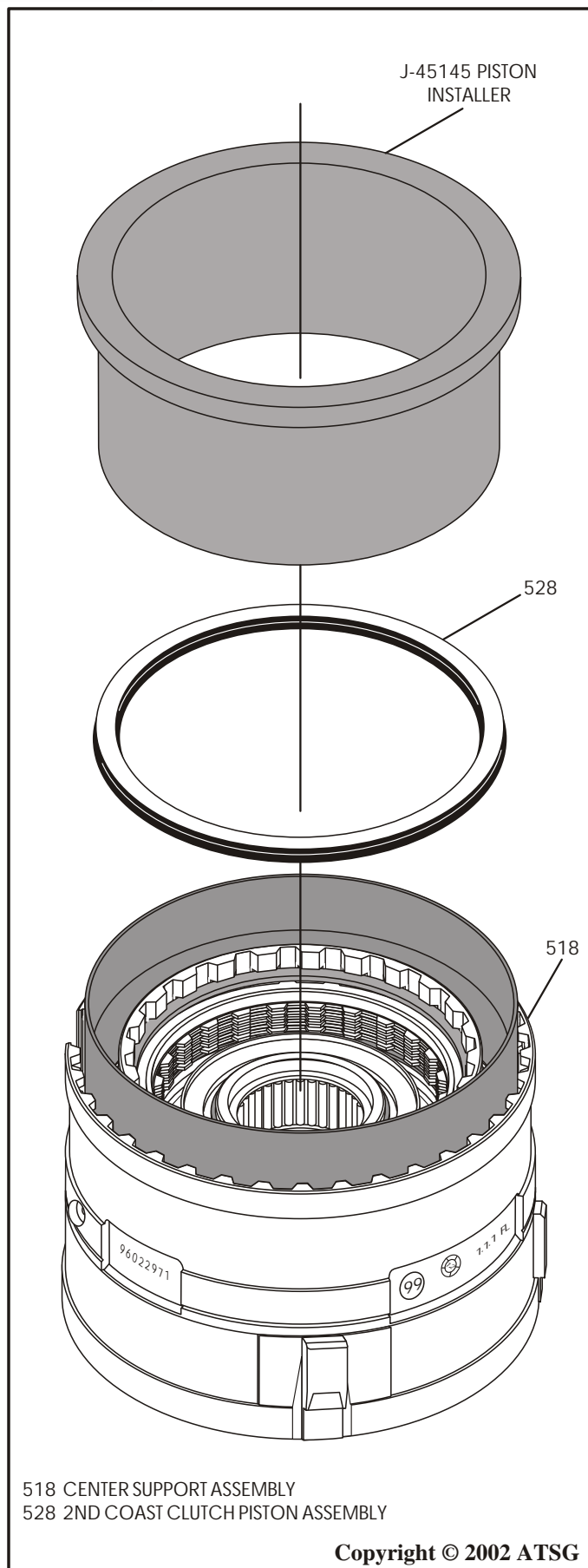

Figure 145

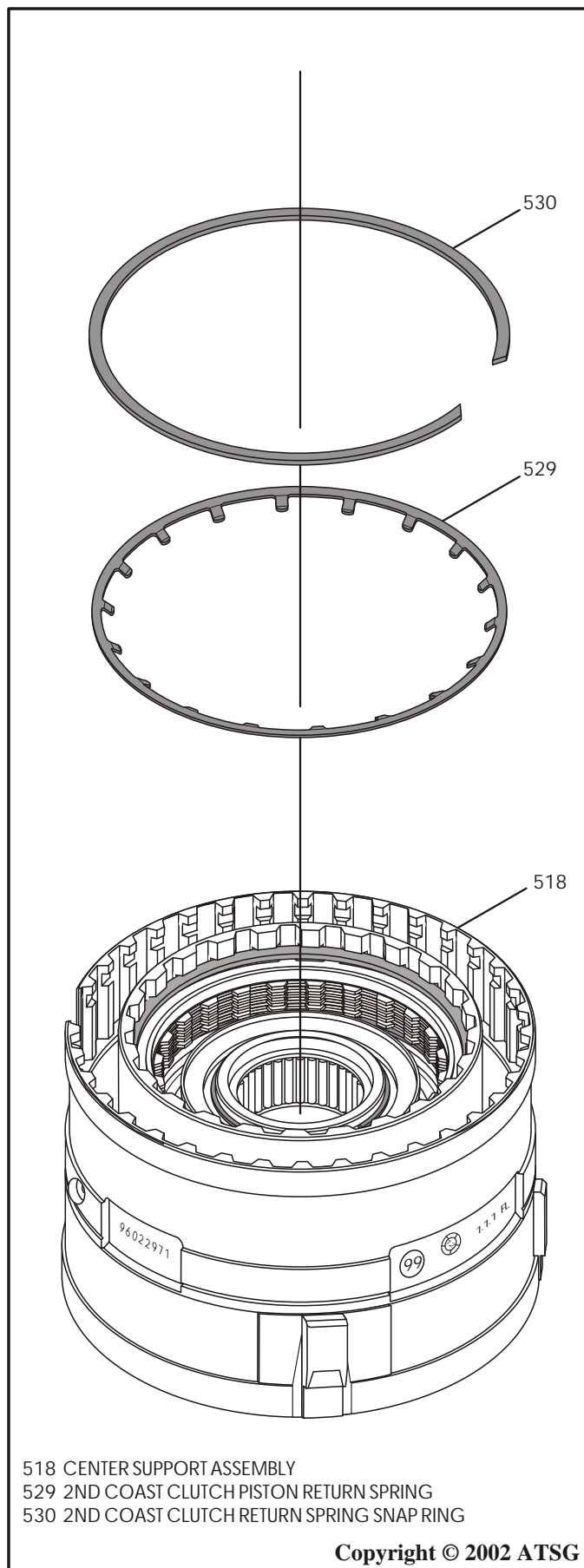

Figure 146



Technical Service Information

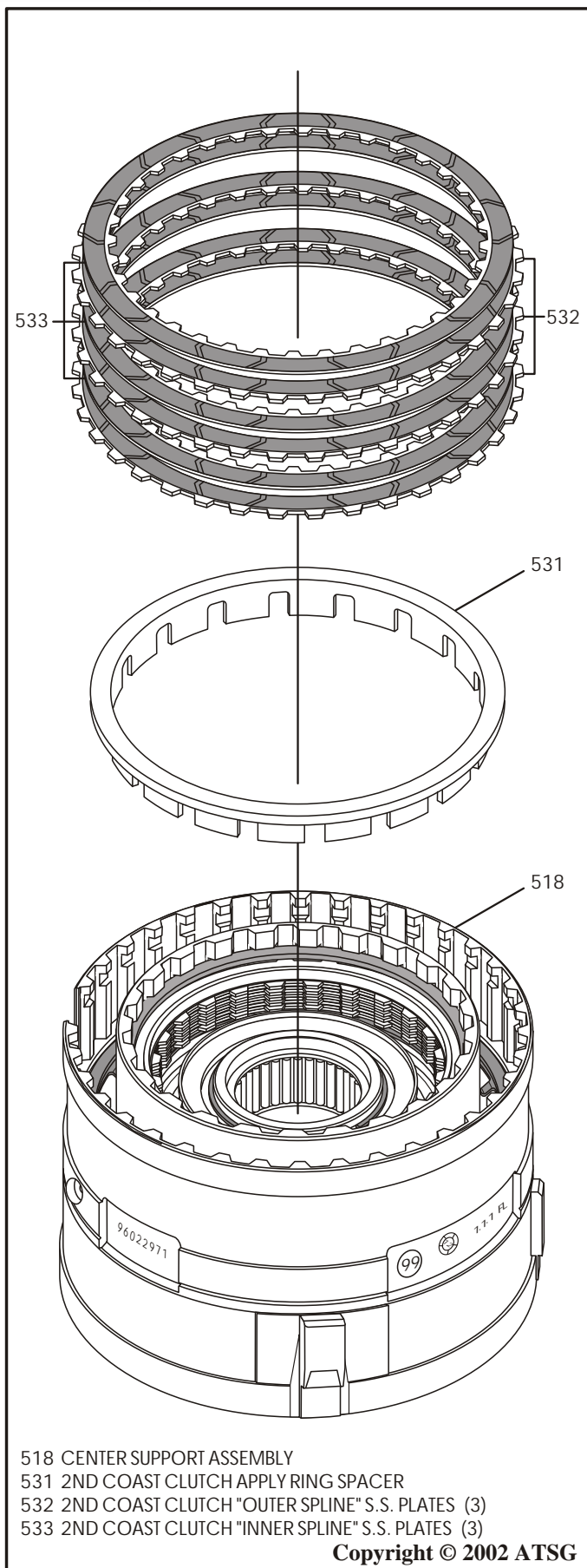

Figure 147

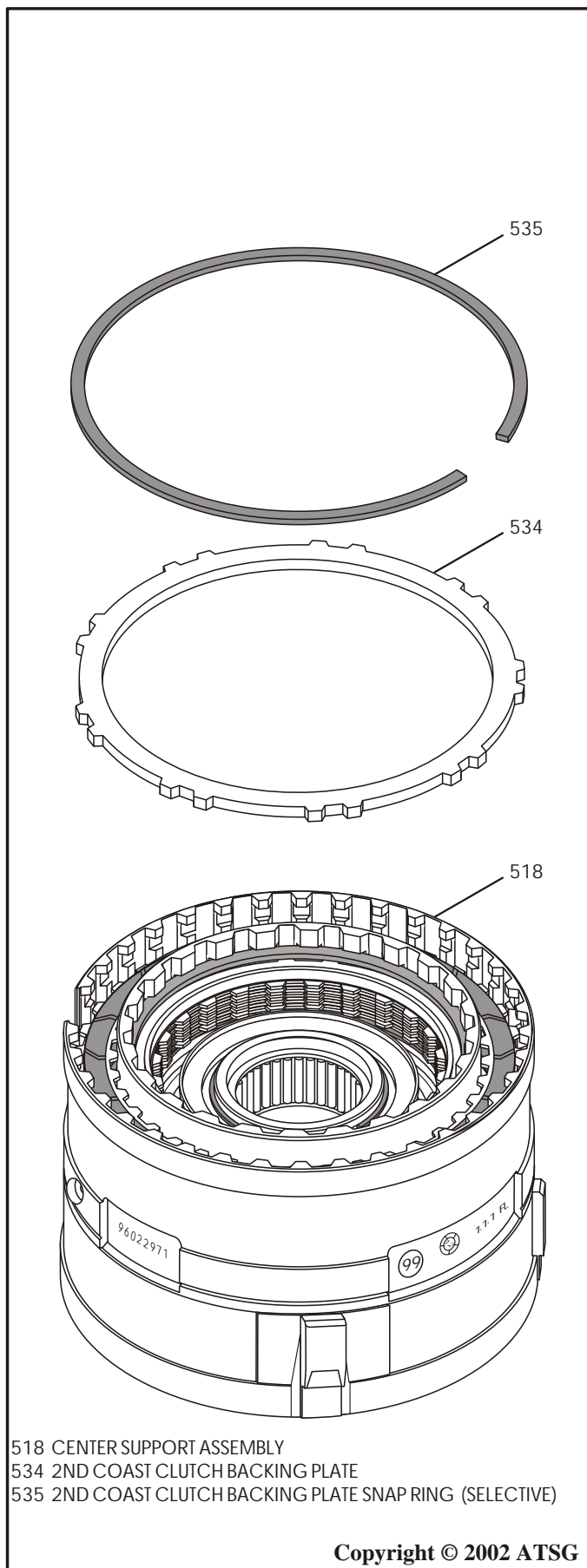

Figure 148



Technical Service Information

CENTER SUPPORT (CONT'D)

33. Install the 2nd coast clutch apply ring spacer, as shown in Figure 147, ensuring that slots are installed over return spring legs.
34. Install 2nd coast clutch "single sided" plates beginning with an outside spline plate first and alternating with inside spline plates until you have installed 3 of each (See Figure 147).
Note: Lined side must be installed facing up, as shown in Figure 147. Clutch plate amounts may vary by model. This set of clutch plates are not used at all in the "4L40-E" models.
35. Install the 2nd coast clutch backing plate, as shown in Figure 148.
36. Install the "Selective" backing plate snap ring, as shown in Figure 148, and ensure that snap ring is fully seated against the top of snap ring groove in the center support.
37. Install dial indicator on top of 2nd coast clutch backing plate, as shown in Figure 149, and zero the dial indicator.
38. 2nd Coast Clutch clearance should be: 0.80 mm (.031") to 1.6 mm (.063"). Change the "Selective" backing plate snap ring as necessary to achieve proper clutch clearance.
39. Set the completed Center Support Assembly aside for final transmission assembly.

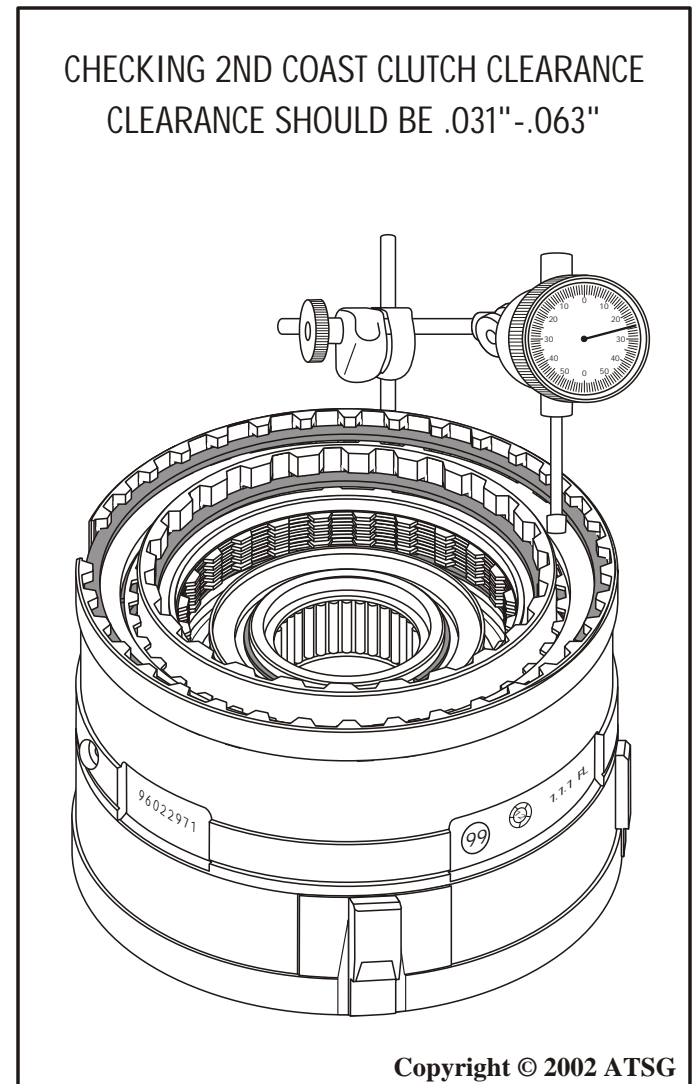
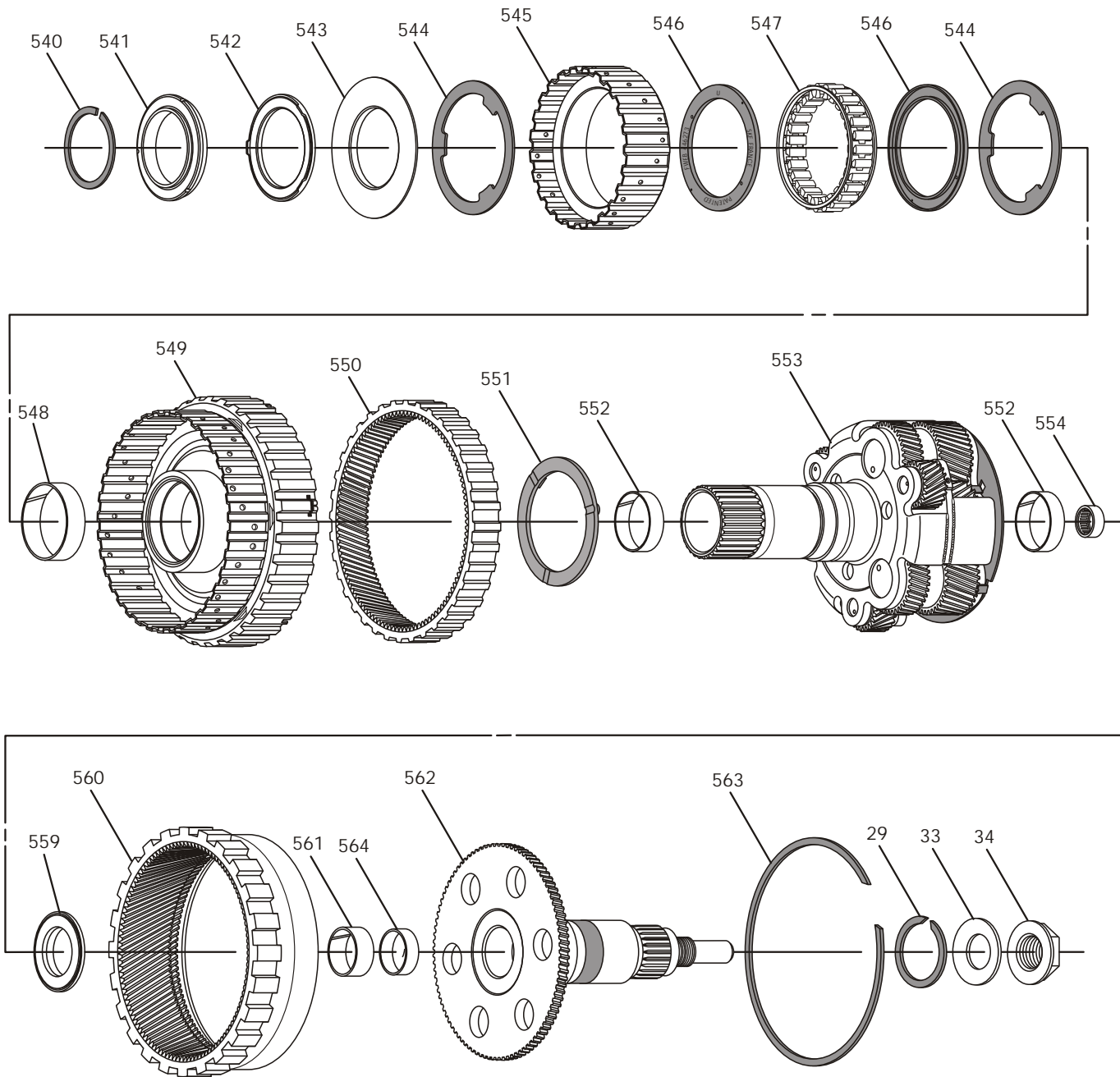

Figure 149



Technical Service Information

5L40-E "ONLY" 2ND SPRAG AND PLANETARY SYSTEM EXPLODED VIEW



"SPECIAL NOTE"
 2ND SPRAG CANNOT BE DIS-ASSEMBLED.
 IF SERVICE IS NECESSARY, IT MUST BE
 REPLACED AS A SERVICE PACKAGE.
 EXPLODED VIEW IS FOR REFERENCE ONLY!

Copyright © 2002 ATSG

Figure 150



Technical Service Information

4L40-E "ONLY" PLANETARY SYSTEM EXPLODED VIEW (2ND SPRAG NOT USED)

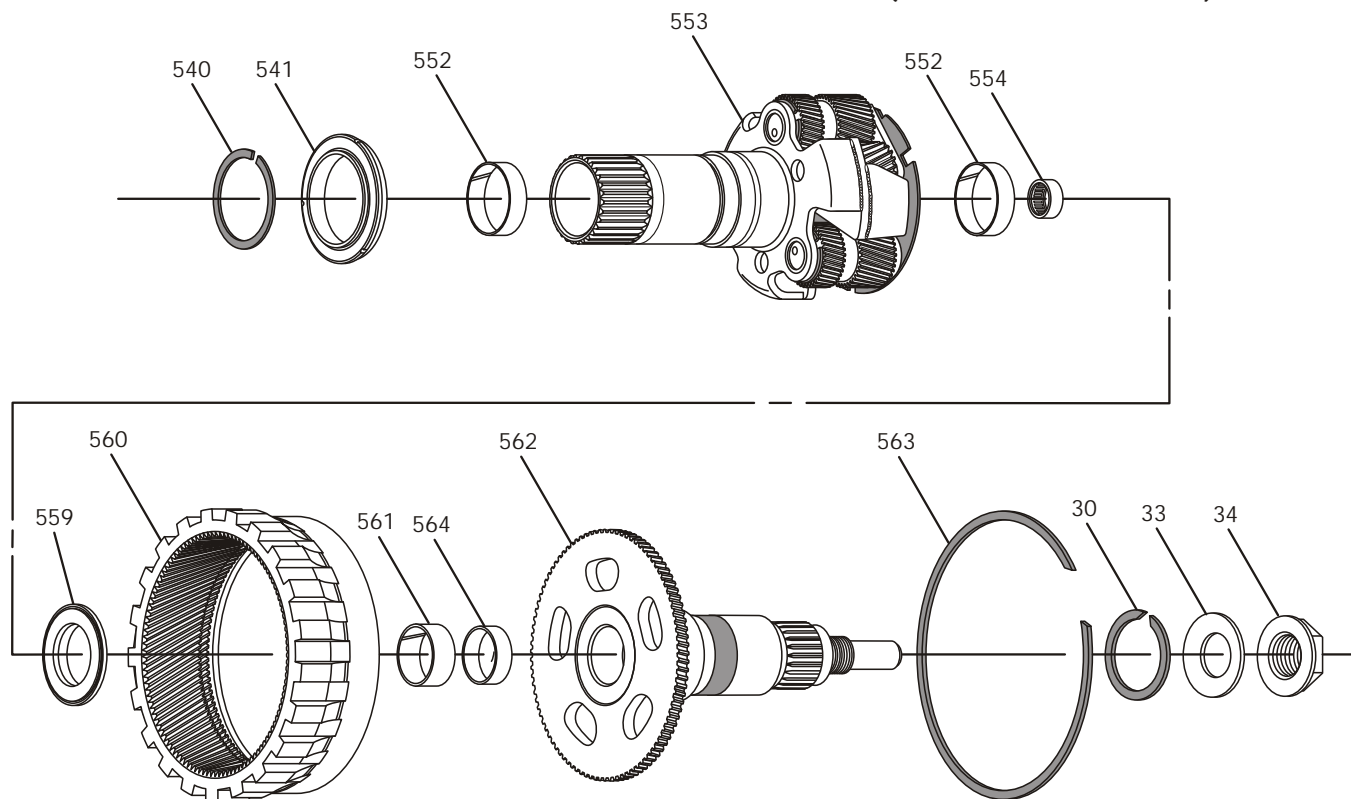

- 29 OUTPUT SHAFT TO DRIVESHAFT YOKE SPACER
- 33 DRIVESHAFT YOKE WASHER
- 34 DRIVESHAFT YOKE RETAINING NUT
- 540 THRUST BEARING RETAINING SNAP RING
- 541 PLANETARY CARRIER THRUST BEARING
- 542 2ND SPRAG ASSEMBLY THRUST BEARING
- 543 2ND CLUTCH SPRAG RETAINER (CRIMPED IN PLACE)
- 544 2ND CLUTCH SPRAG OUTER RACE THRUST WASHER (2)
- 545 2ND CLUTCH SPRAG OUTER RACE
- 546 2ND CLUTCH SPRAG END BEARING (2)
- 547 2ND CLUTCH SPRAG AND CAGE ASSEMBLY
- 548 2ND CLUTCH SPRAG INNER RACE AND HUB BUSHING

- 549 2ND CLUTCH SPRAG INNER RACE AND HUB ASSEMBLY
- 550 REACTION INTERNAL RING GEAR
- 551 PLANETARY TO 2ND SPRAG/HUB THRUST WASHER
- 552 PLANETARY CARRIER BUSHING (2)
- 553 PLANETARY CARRIER ASSEMBLY
- 554 PLANETARY CARRIER CAGED NEEDLE BEARING
- 559 OUTPUT SHAFT TO PLANETARY CARRIER THRUST BEARING
- 560 REAR INTERNAL RING GEAR
- 561 OUTPUT SHAFT BUSHING
- 562 OUTPUT SHAFT ASSEMBLY
- 563 OUTPUT SHAFT TO REAR RING GEAR RETAINING SNAP RING
- 564 OUTPUT SHAFT CUP PLUG

Copyright © 2002 ATSG

Figure 151



Technical Service Information

COMPONENT REBUILD

"5L40-E" PLANETARY SYSTEM

1. Dis-assemble the planetary carrier system using Figures 150 and 151 as a guide.
2. Clean all planetary system parts thoroughly and dry with compressed air.
3. Inspect all planetary system parts thoroughly for any wear and/or damage.

Note: The 2nd Sprag Assembly cannot be dis-assembled. Exploded view is for reference only.

4. Inspect the Sprag Assembly for proper hold and freewheel operation (See Figure 152).
5. If replacement is necessary, 2nd sprag must be serviced as a complete assembly.
6. Install thrust washer (551) on 5L40-E carrier as shown in Figure 153.
7. Install 2nd sprag and hub assembly on 5L40-E carrier, as shown in Figure 153.
8. Install thrust bearing (542) on top of 2nd sprag assembly, as shown in Figure 156.
9. Install thrust bearing (541) on top of thrust bearing 542, as shown in Figure 156

Continued on Page 97

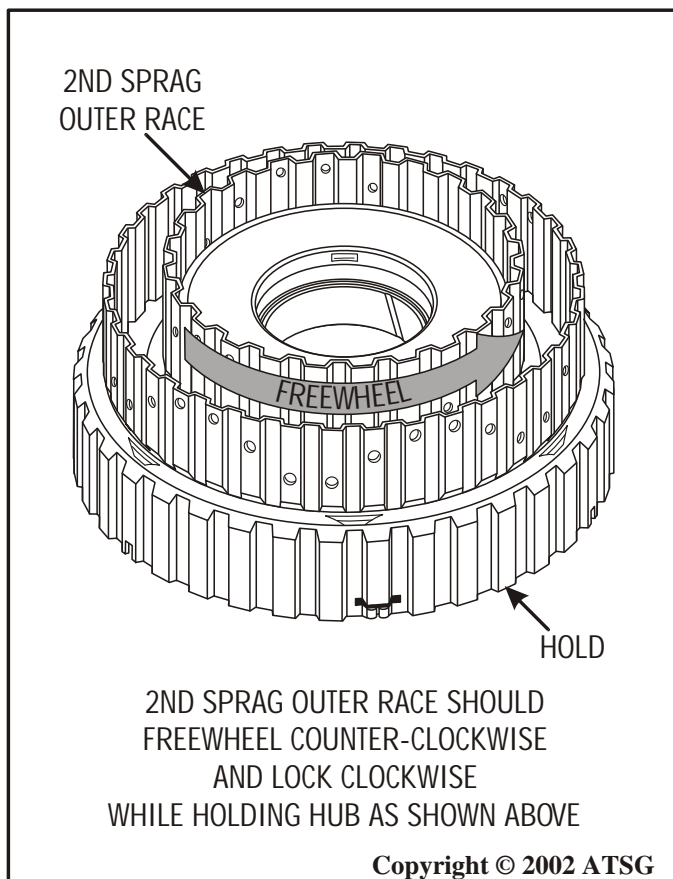
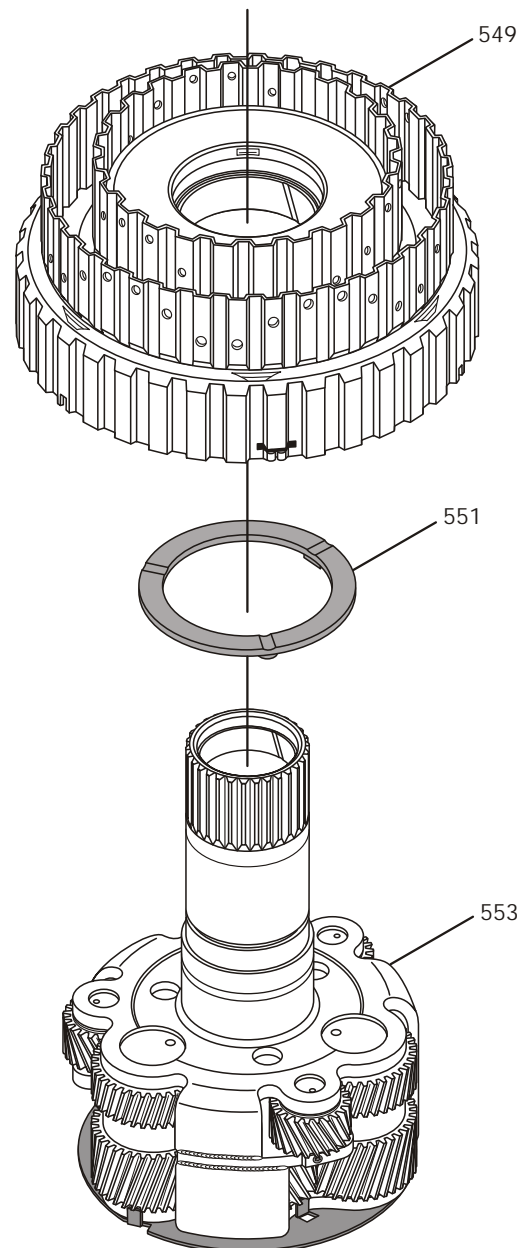

Figure 152

5L40-E PLANETARY CARRIER

"SPECIAL NOTE"

2ND SPRAG CANNOT BE DIS-ASSEMBLED IF SERVICE IS NECESSARY, IT MUST BE REPLACED AS A SERVICE PACKAGE. EXPLODED VIEW IS FOR REFERENCE ONLY!



549 COMPLETE 2ND SPRAG AND HUB ASSEMBLY (5L40-E ONLY)
551 2ND SPRAG TO PLANETARY THRUST WASHER (5L40-E ONLY)
553 5L40-E PLANETARY CARRIER ASSEMBLY

Copyright © 2002 ATSG

Figure 153



Technical Service Information

"5L40-E" PLANETARY SYSTEM (CONT'D)

10. Thrust bearing identification for these two bearings is provided in Figure 154.
11. Install the retaining snap ring, as shown in Figure 156, and ensure that it is fully seated.
12. Set the completed 5L40-E planetary carrier assembly, as shown in Figure 155, aside for the final transmission assembly process.

Continued on Page 98

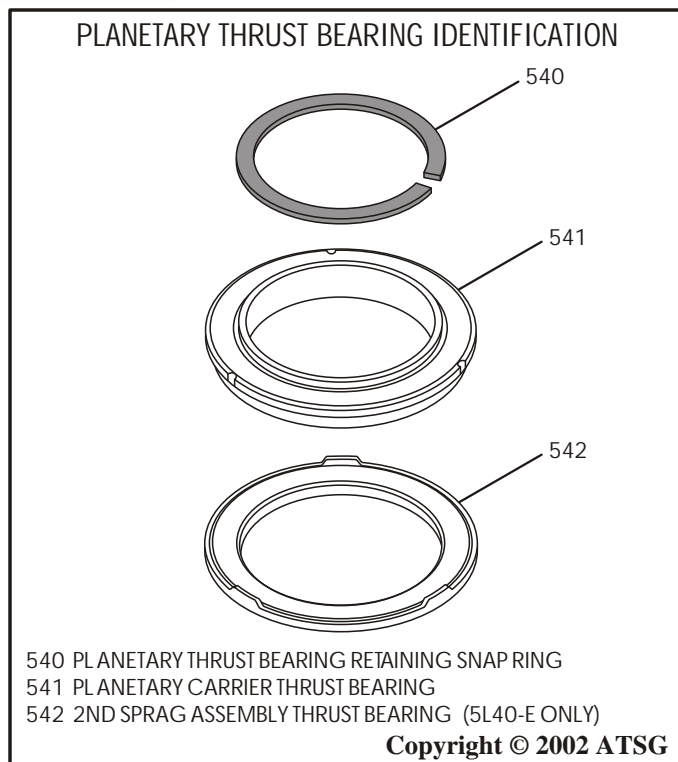

Figure 154

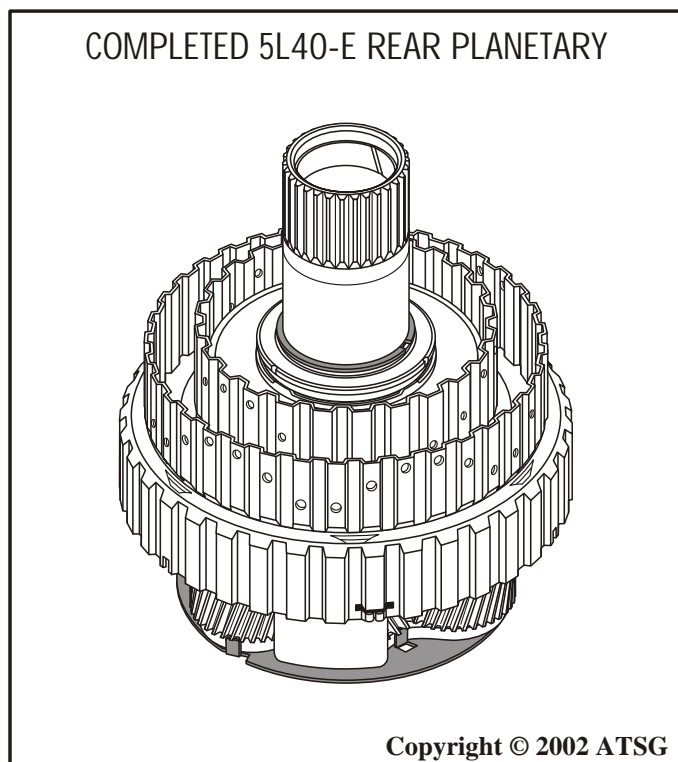

Figure 155

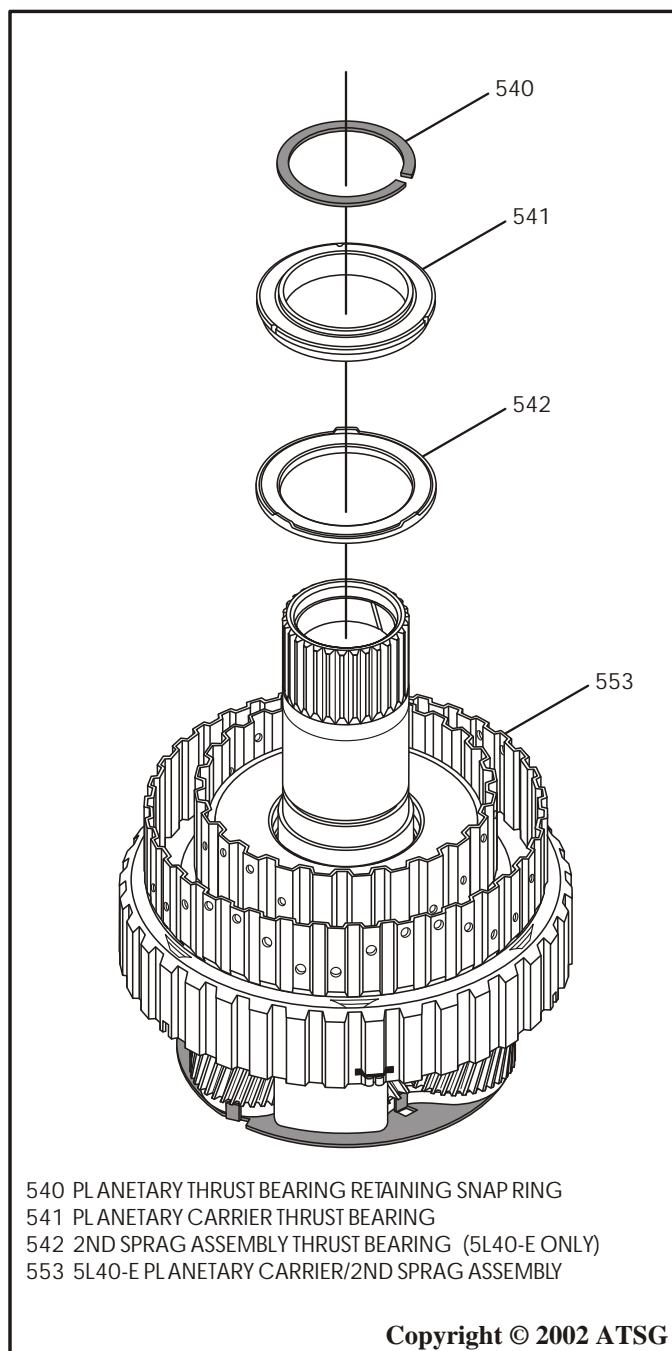

Figure 156



Technical Service Information

"5L40-E" PLANETARY SYSTEM (CONT'D)

13. Install output shaft into the output internal ring gear, as shown in Figure 158.
14. Install the internal ring gear snap ring into the groove in ring gear, as shown in Figure 158, and ensure that it is fully seated.
15. Install driveshaft yoke spacer onto output shaft against the flat surface (See Figure 158).
16. Install thrust bearing (559) onto output shaft, as shown in Figure 158, and retain with small amount of Trans-Jel®.
17. Set the completed 5L40-E output shaft, as shown in Figure 157, aside for the final transmission assembly process.

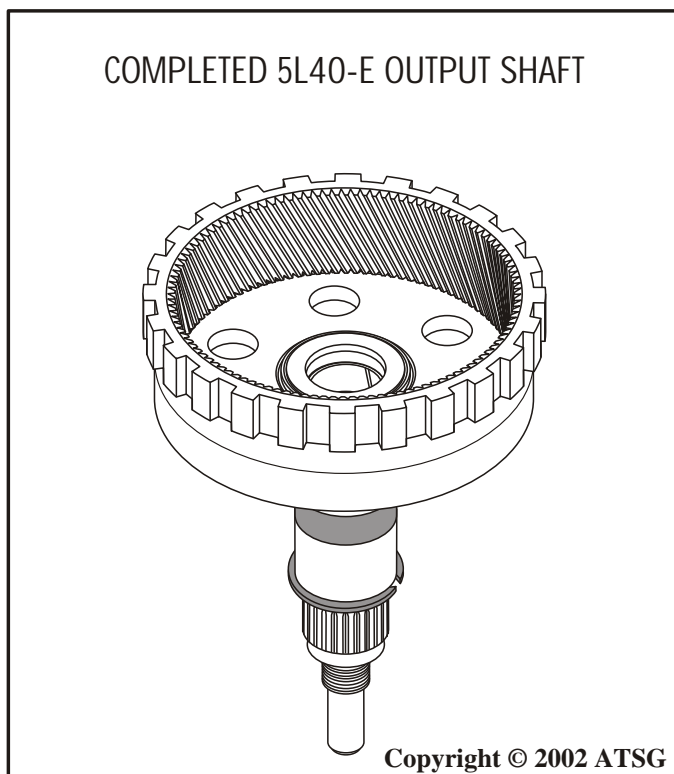
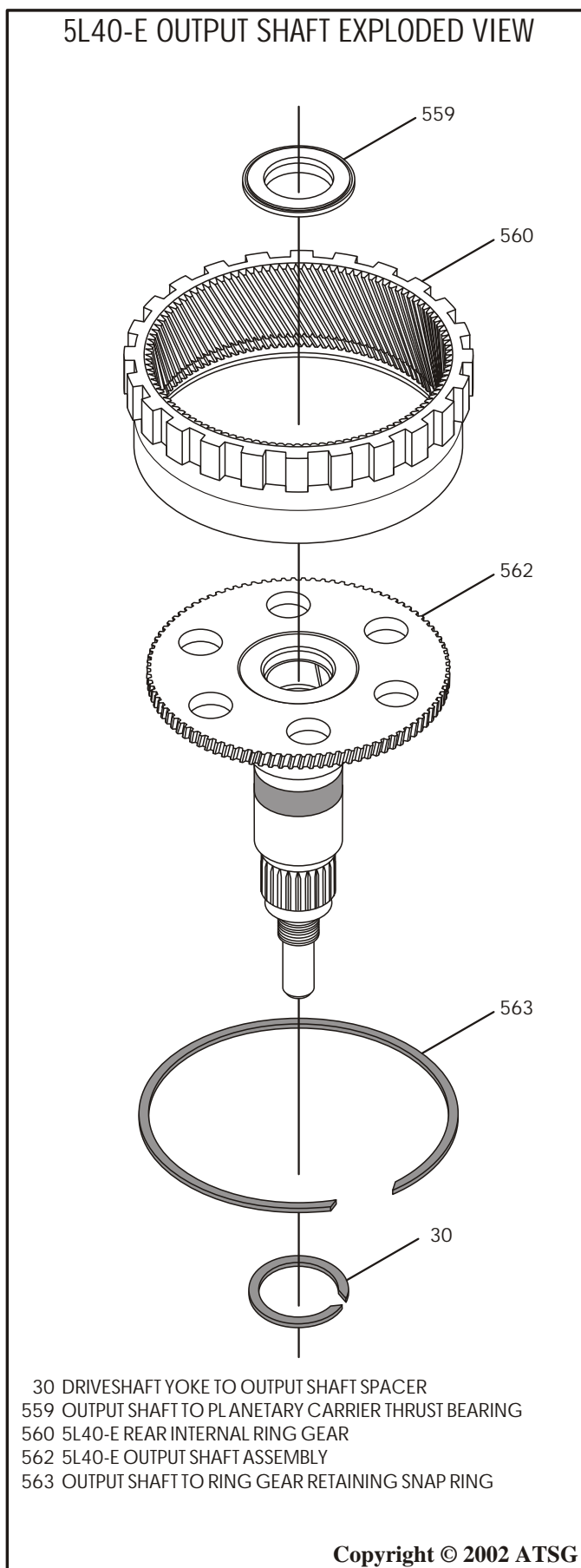

Figure 157



- 30 DRIVESHAFT YOKE TO OUTPUT SHAFT SPACER
 559 OUTPUT SHAFT TO PLANETARY CARRIER THRUST BEARING
 560 5L40-E REAR INTERNAL RING GEAR
 562 5L40-E OUTPUT SHAFT ASSEMBLY
 563 OUTPUT SHAFT TO RING GEAR RETAINING SNAP RING

Figure 158



Technical Service Information

COMPONENT REBUILD

"4L40-E" PLANETARY SYSTEM

1. Install thrust bearing (541) onto the 4L40-E planetary carrier, as shown in Figure 159, and down flush on step.
2. Install the retaining snap ring onto planetary carrier, as shown in Figure 159, and ensure that it is fully seated.
3. Set the completed 4L40-E planetary carrier, as shown in Figure 160, for final assembly.
4. Install output shaft into the output internal ring gear, as shown in Figure 162.
5. Install the internal ring gear snap ring into the groove in ring gear, as shown in Figure 162, and ensure that it is fully seated.
6. Install driveshaft yoke spacer onto output shaft against the flat surface (See Figure 162).
7. Install thrust bearing (559) onto output shaft, as shown in Figure 162, and retain with small amount of Trans-Jel®.
8. Set the completed 4L40-E output shaft, as shown in Figure 161, aside for the final transmission assembly process.

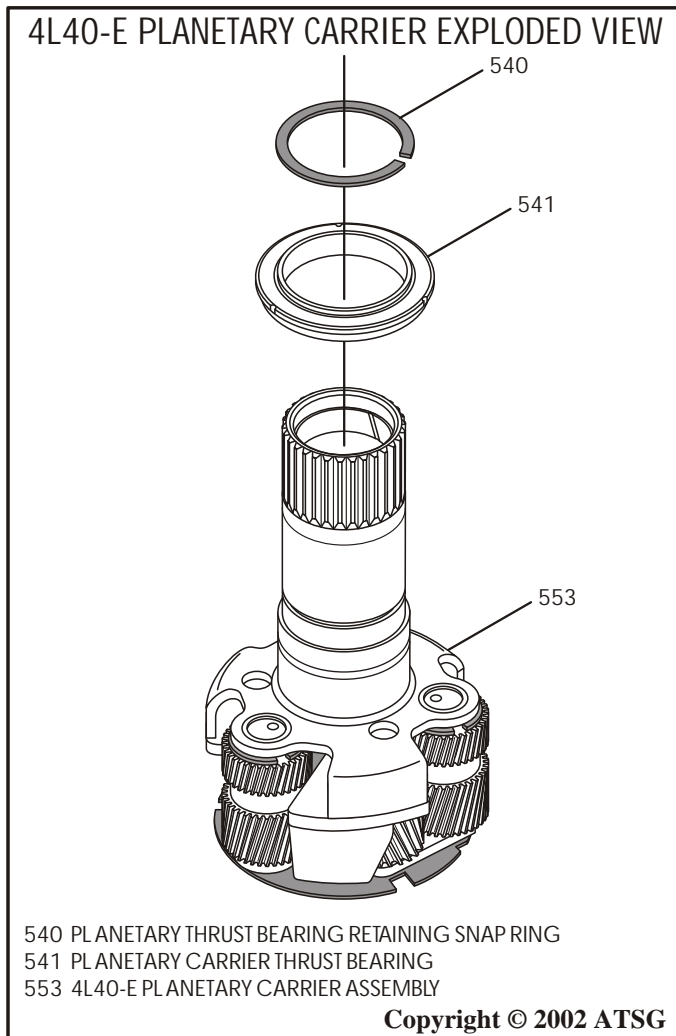

Figure 159

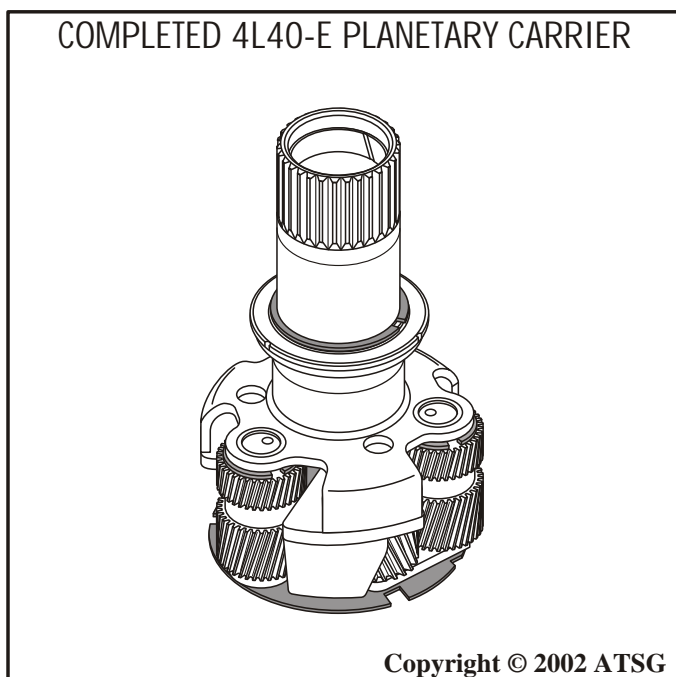

Figure 160

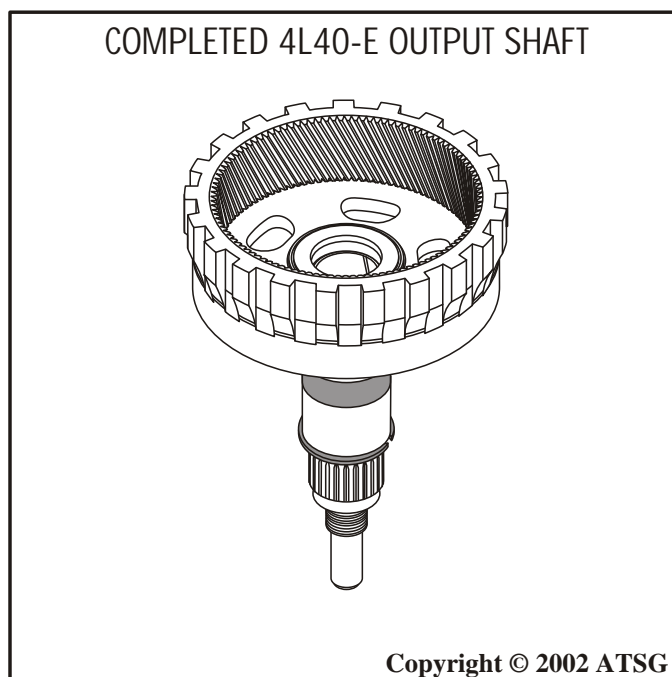
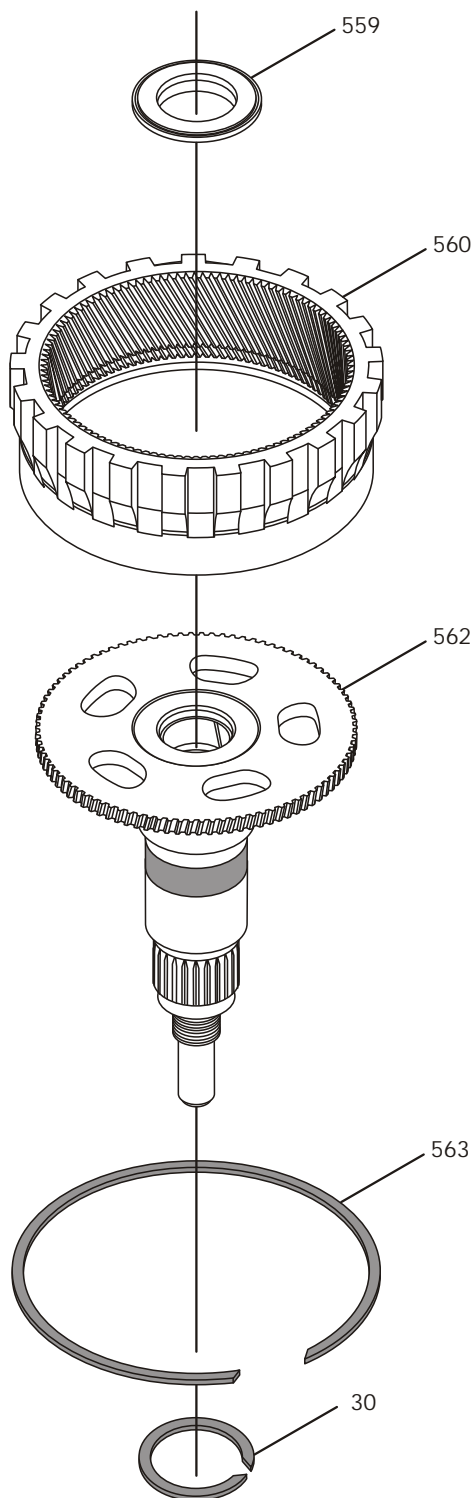

Figure 161



Technical Service Information

4L40-E OUTPUT SHAFT EXPLODED VIEW



- 30 DRIVESHAFT YOKE TO OUTPUT SHAFT SPACER
- 559 OUTPUT SHAFT TO PLANETARY CARRIER THRUST BEARING
- 560 4L40-E REAR INTERNAL RING GEAR
- 562 4L40-E OUTPUT SHAFT ASSEMBLY
- 563 OUTPUT SHAFT TO RING GEAR RETAINING SNAP RING

Copyright © 2002 ATSG

Figure 162

- 300 TOP CHANNEL PLATE TO VALVE BODY BOLTS (7)
- 301 TOP CHANNEL PLATE ASSEMBLY
- 302 NUMBER 7 CHECKBALL SPRING
- 303 TOP CHANNEL PLATE TO BOTTOM CHANNEL PLATE GASKET
- 304 BOTTOM CHANNEL PLATE ASSEMBLY
- 305 UPPER SPACER PLATE GASKET
- 306 NUMBER 7 CHECKBALL
- 307 VALVE BODY SPACER PLATE
- 308 TCC/PWM SOLENOID SCREEN ASSEMBLY
- 309 LOWER SPACER PLATE GASKET
- 310 REAR VALVE BODY ASSEMBLY
- 311 FRONT VALVE BODY ASSEMBLY
- 312 PRESSURE CONTROL SOLENOID SCREEN ASSEMBLY
- 313 DIRECT CLUTCH ACCUMULATOR PISTON SPRING
- 314 DIRECT CLUTCH ACCUMULATOR PISTON LARGE SEAL RING
- 315 DIRECT CLUTCH ACCUMULATOR PISTON
- 316 DIRECT CLUTCH ACCUMULATOR PISTON SMALL SEAL RING
- 317 DIRECT CLUTCH ACCUMULATOR HOUSING
- 318 ACCUMULATOR HOUSING BOLTS (3 PER HOUSING)
- 319 OVERDRIVE CLUTCH ACCUMULATOR PISTON SPRING
- 320 O.D. CLUTCH ACCUMULATOR PISTON LARGE SEAL RING
- 321 OVERDRIVE CLUTCH ACCUMULATOR PISTON
- 322 O.D. CLUTCH ACCUMULATOR PISTON SMALL SEAL RING
- 323 OVERDRIVE CLUTCH ACCUMULATOR HOUSING
- 324 INTERMEDIATE CLUTCH ACCUMULATOR PISTON SPRING
- 325 INTERM. CLUTCH ACCUMULATOR PISTON LARGE SEAL RING
- 326 INTERMEDIATE CLUTCH ACCUMULATOR PISTON
- 327 INTERM. CLUTCH ACCUMULATOR PISTON SMALL SEAL RING
- 328 INTERMEDIATE CLUTCH ACCUMULATOR HOUSING
- 329 2ND CLUTCH ACCUMULATOR PISTON SPRING
- 330 2ND CLUTCH ACCUMULATOR PISTON LARGE SEAL RING
- 331 2ND CLUTCH ACCUMULATOR PISTON
- 332 2ND CLUTCH ACCUMULATOR PISTON SMALL SEAL RING
- 333 2ND CLUTCH ACCUMULATOR HOUSING

Copyright © 2002 ATSG

Figure 163 Legend



Technical Service Information

VALVE BODY ASSEMBLY EXPLODED VIEW

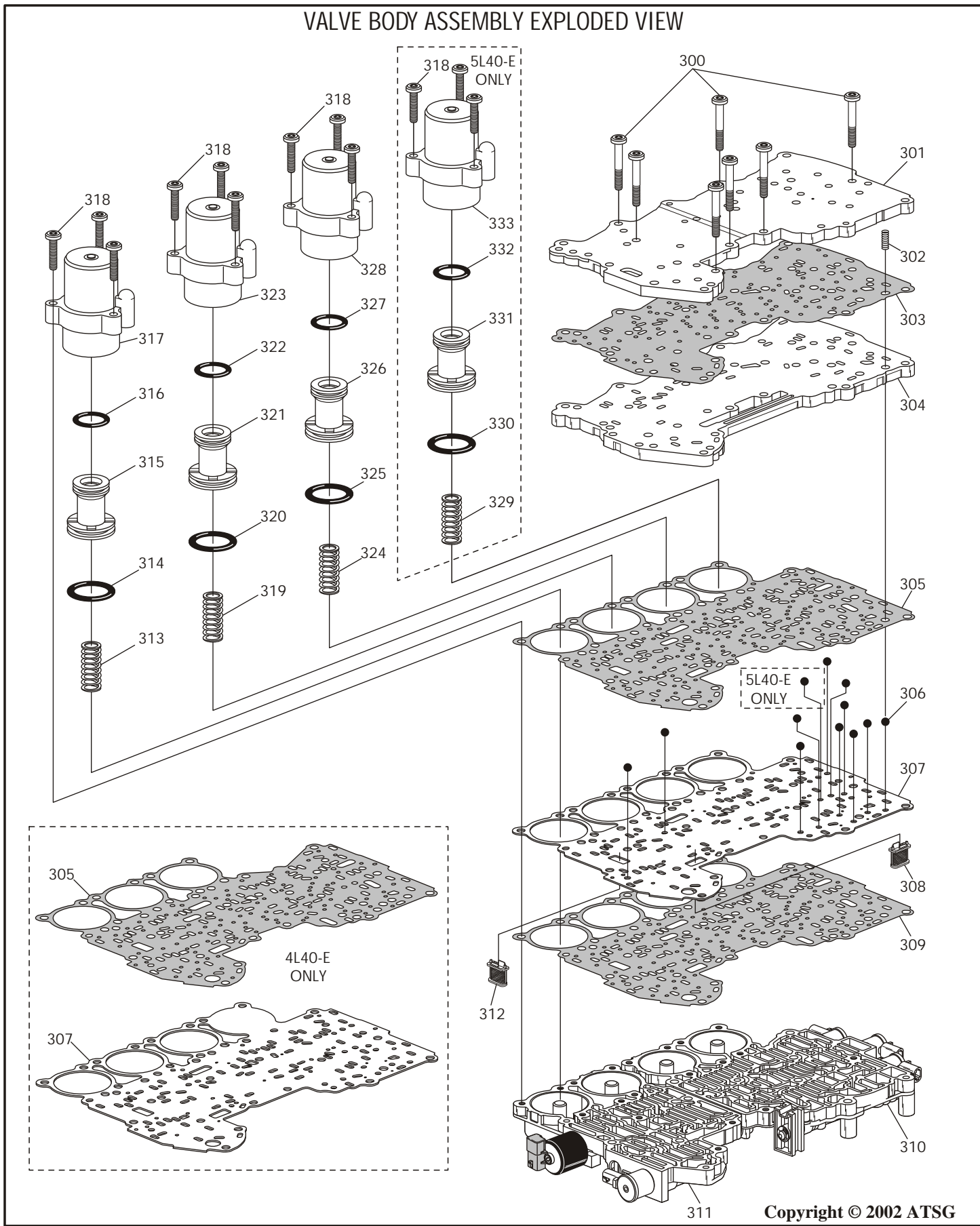

Copyright © 2002 ATSG

Figure 163



Technical Service Information

COMPONENT REBUILD

VALVE BODY ASSEMBLY

1. Dis-assemble complete valve body assembly using Figure 163 as a guide.
2. Remove and discard both valve body gaskets. Refer to Figure 163.
3. Clean all valve body parts thoroughly and dry with compressed air.
4. Inspect all valve body parts thoroughly for any wear and/or damage.
5. Dis-assemble the front valve body assembly using Figure 164 as a guide.
6. Lay each valve line-up out in order as you remove them from the valve body casting.
7. Inspect each valve, valve spring, bore plug and retainers for any wear and/or damage.
8. Clean all front valve body parts thoroughly and dry with compressed air.
9. Install each valve train back into their bores **exactly** as shown in Figure 164, lubricating them with Dexron III® as they are installed.
10. Install new "O" ring seals on the TCC/PWM Solenoid and the Pressure Control Solenoid as they are installed (See Figure 164).
11. Extra care here will eliminate some of the troublesome problems encountered later.
12. Dis-assemble the rear valve body assembly using Figure 165 as a guide.
13. Lay each valve line-up out in order as you remove them from the valve body casting.
14. Inspect each valve, valve spring, bore plug and retainers for any wear and/or damage.

FRONT VALVE BODY ASSEMBLY EXPLODED VIEW

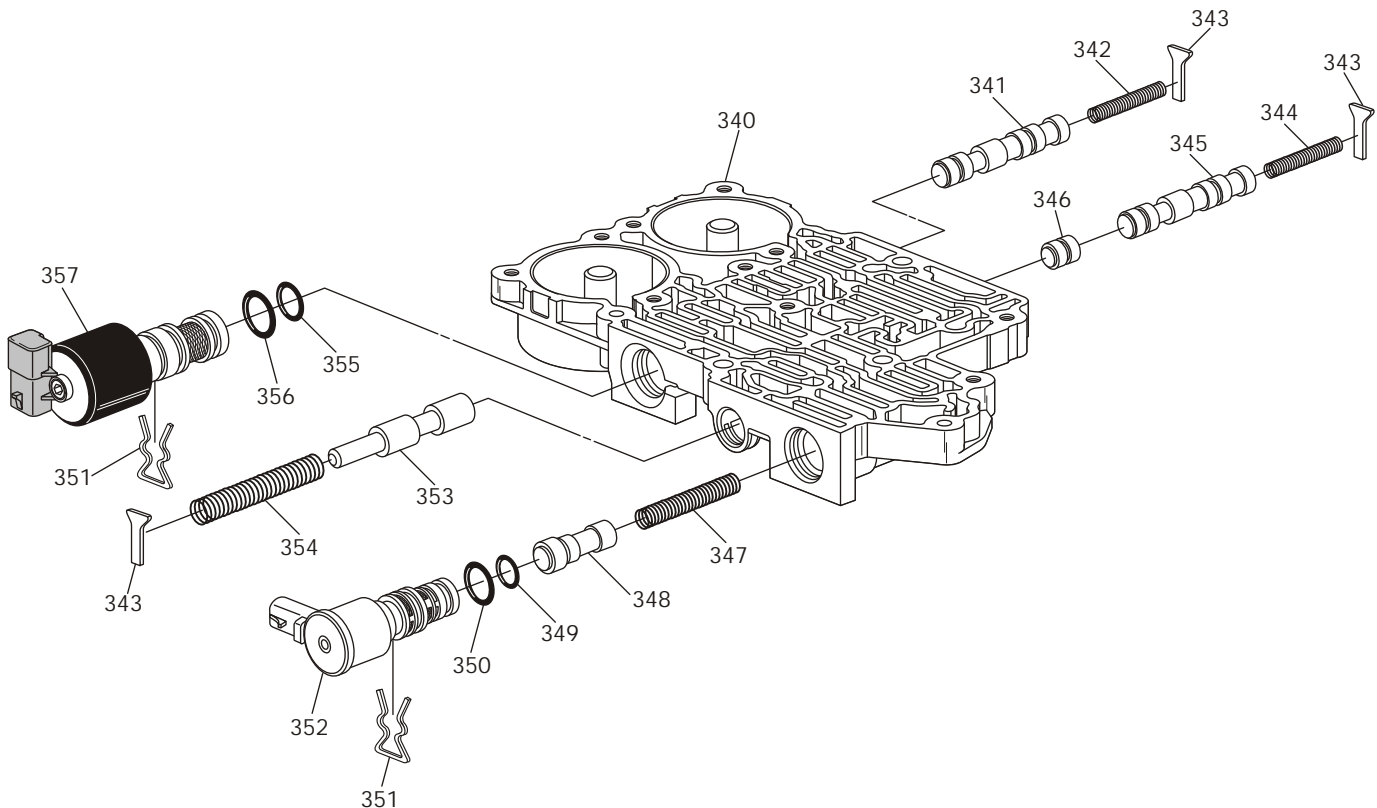

340 FRONT VALVE BODY CASTING ASSEMBLY
 341 SAFETY MODE VALVE
 342 SAFETY MODE VALVE SPRING
 343 VALVE SPRING RETAINER
 344 3-4 SHIFT VALVE SPRING
 345 3-4 SHIFT VALVE
 346 3-4 SHIFT CONTROL VALVE
 347 TCC REGULATOR APPLY VALVE SPRING
 348 TCC REGULATOR APPLY VALVE

349 SOLENOID ASSEMBLY SMALL "O" RING SEAL
 350 SOLENOID ASSEMBLY LARGE "O" RING SEAL
 351 SOLENOID ASSEMBLY RETAINER
 352 TCC/PWM SOLENOID ASSEMBLY
 353 FEED LIMIT VALVE
 354 FEED LIMIT VALVE SPRING
 355 PRESSURE CONTROL SOLENOID SMALL "O" RING SEAL
 356 PRESSURE CONTROL SOLENOID LARGE "O" RING SEAL
 357 PRESSURE CONTROL SOLENOID ASSEMBLY

Copyright © 2002 ATSG

Figure 164



Technical Service Information

VALVE BODY ASSEMBLY (CONT'D)

15. Clean all front valve body parts thoroughly and dry with compressed air.
16. Install each valve train back into their bores **exactly** as shown in Figure 165, lubricating them with Dexron III® as they are installed.

17. Install new "O" ring seals on all three of the Shift Solenoids as they are installed, as shown in Figure 165.
18. Extra care here will eliminate some of the troublesome problems encountered later.

Continued on Page 104

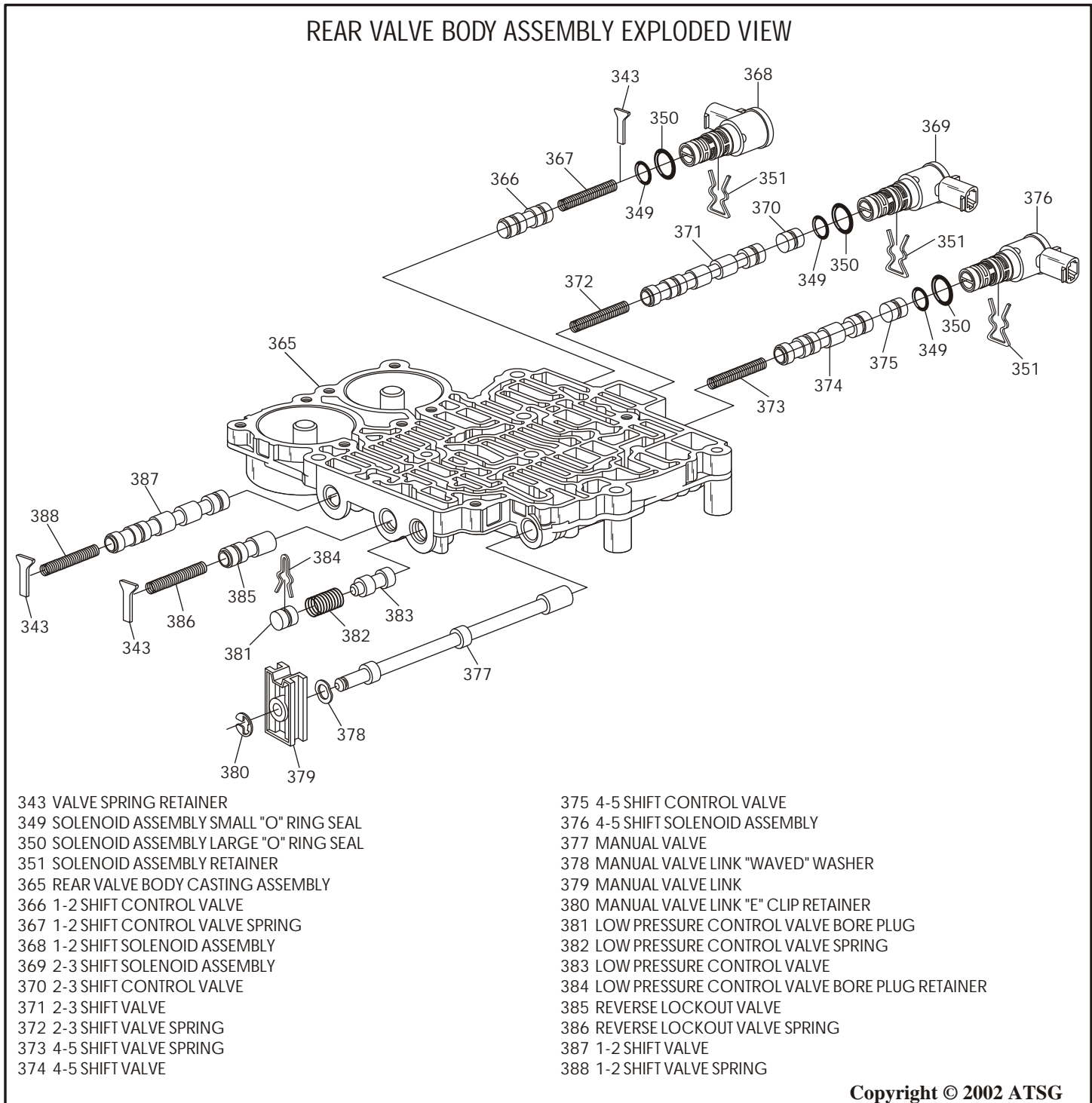

Copyright © 2002 ATSG

Figure 165



Technical Service Information

VALVE BODY ASSEMBLY (CONT'D)

19. Lay both front and rear valve body assemblies on a flat work surface *exactly* as they are laid out in Figure 166.
20. Install the four J-39068 guide pins in locations shown in Figure 166.
21. Install two new screens into the spacer plate in locations shown in Figure 166.
22. Install lower spacer plate gasket over the guide pins as shown in Figure 166.
23. Install spacer plate over guide pins, as shown in Figure 166.

24. Install upper spacer plate gasket over the guide pins, as shown in Figure 167.
25. Install valve body checkballs into their proper locations in the lower channel plate, as shown in Figure 168.

Note: Retain the checkballs in channel plate with "Small" amount of Trans-Jel®.

26. Install the lower channel plate with checkballs over the guide pins, as shown in Figure 167.

Continued on Page 107

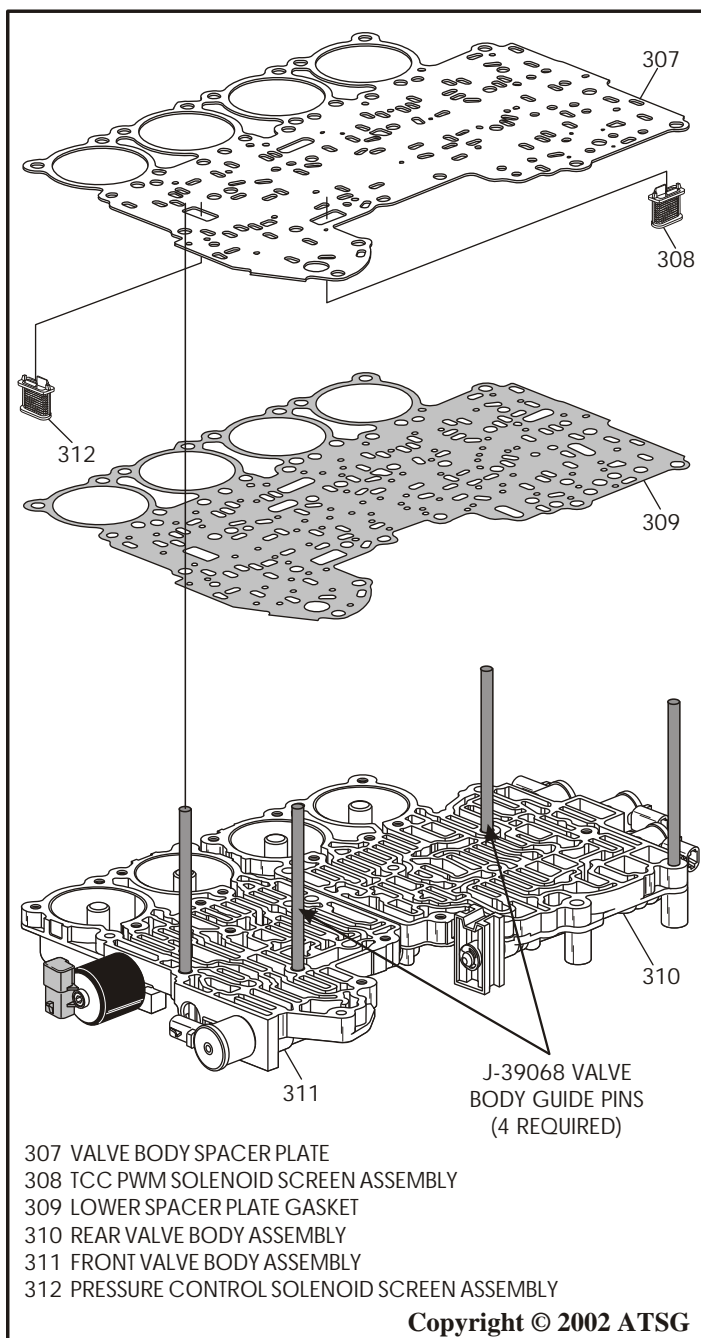

Figure 166

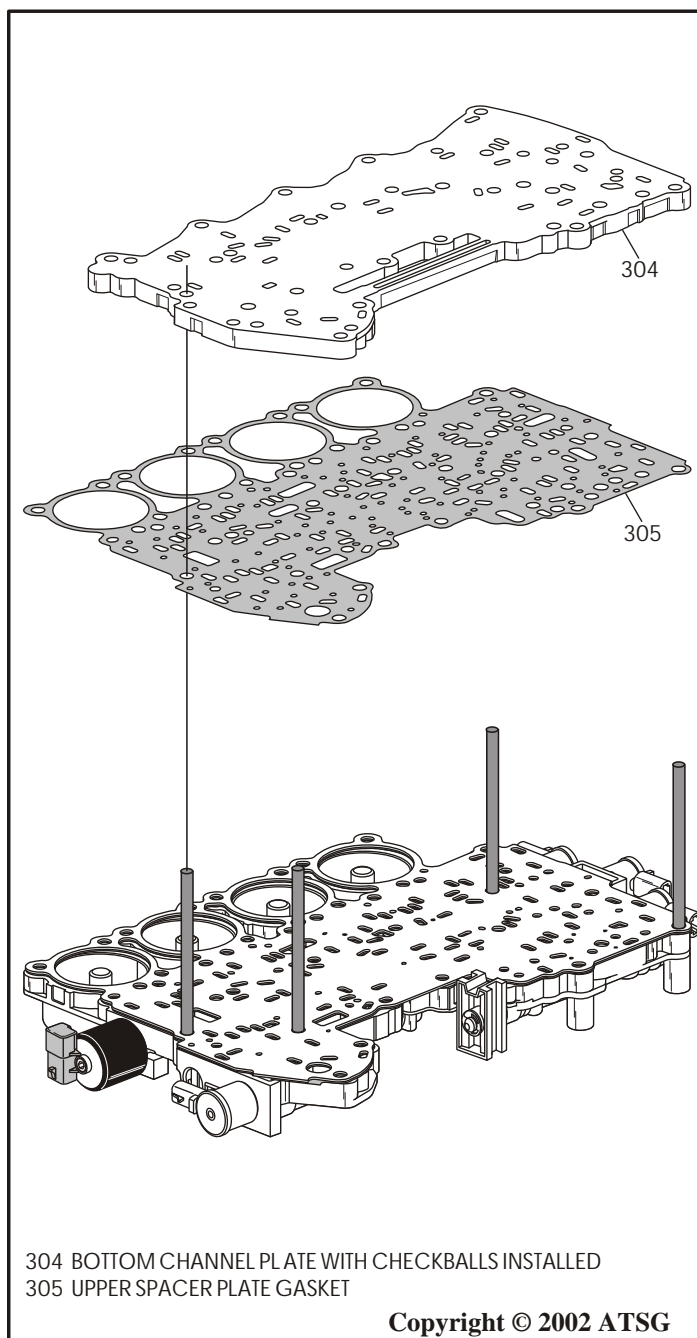
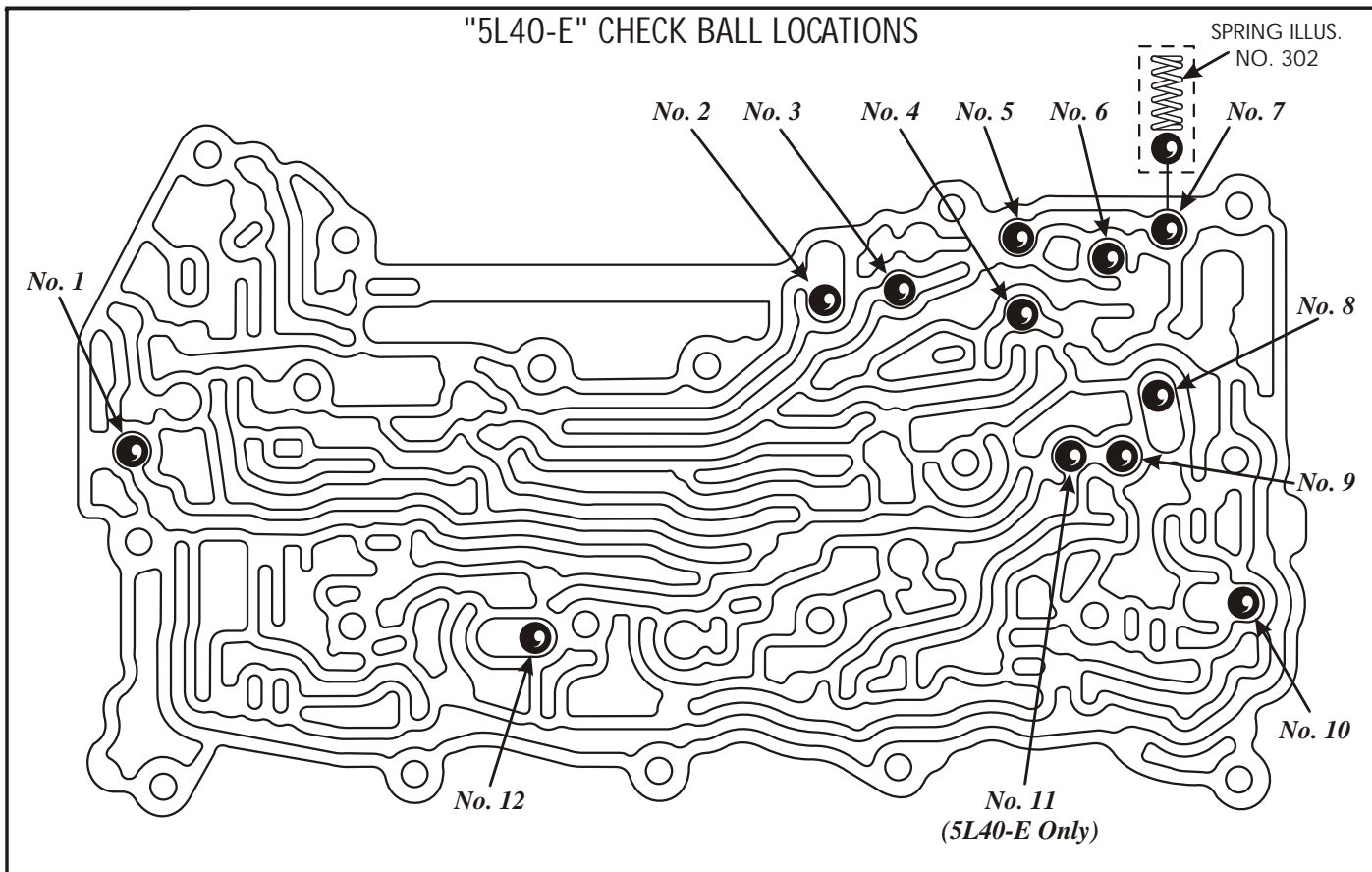

Figure 167



Technical Service Information

"5L40-E" CHECK BALL LOCATIONS



"4L40-E" CHECK BALL LOCATIONS

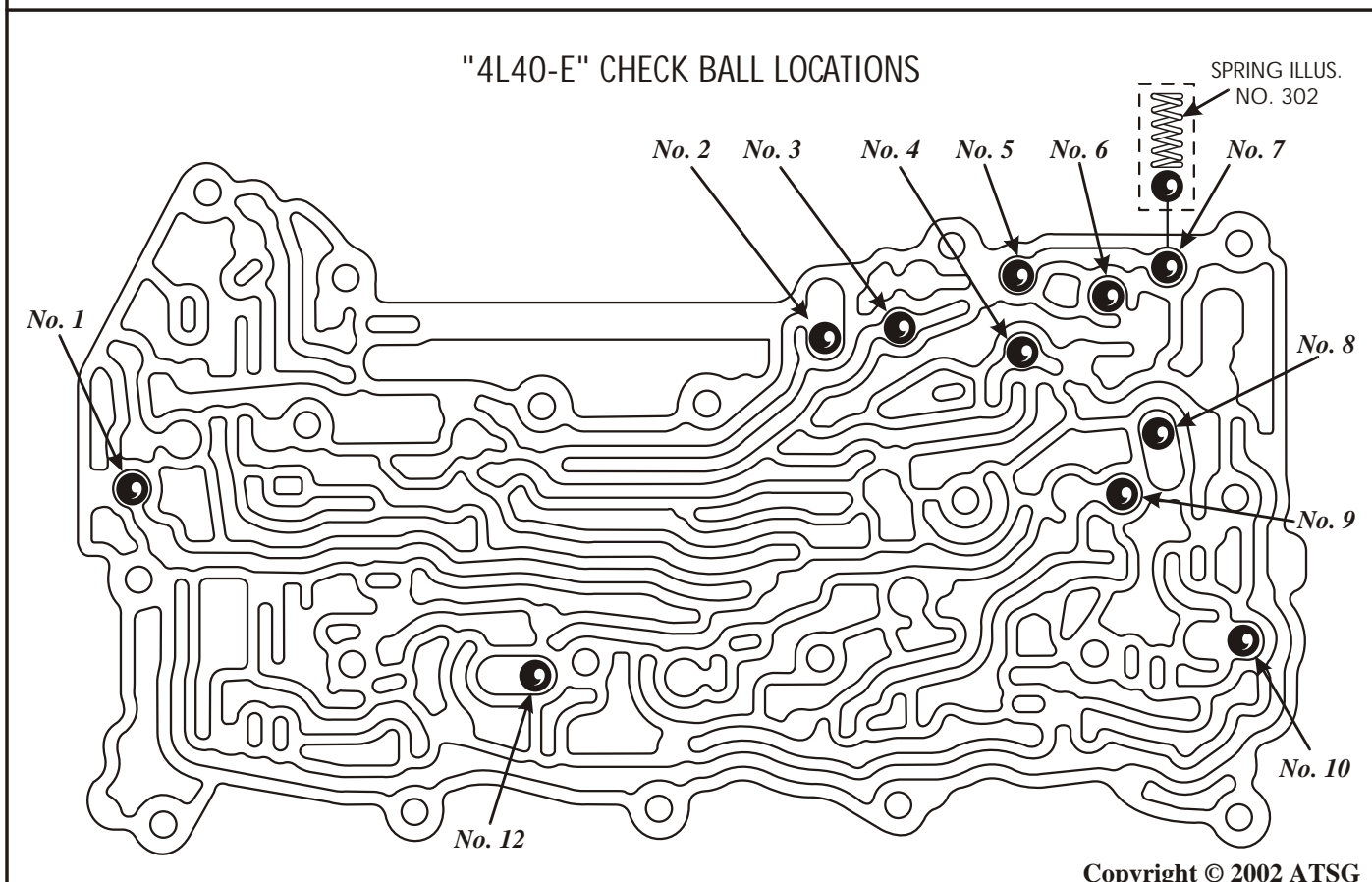

Copyright © 2002 ATSG

Figure 168



Technical Service Information

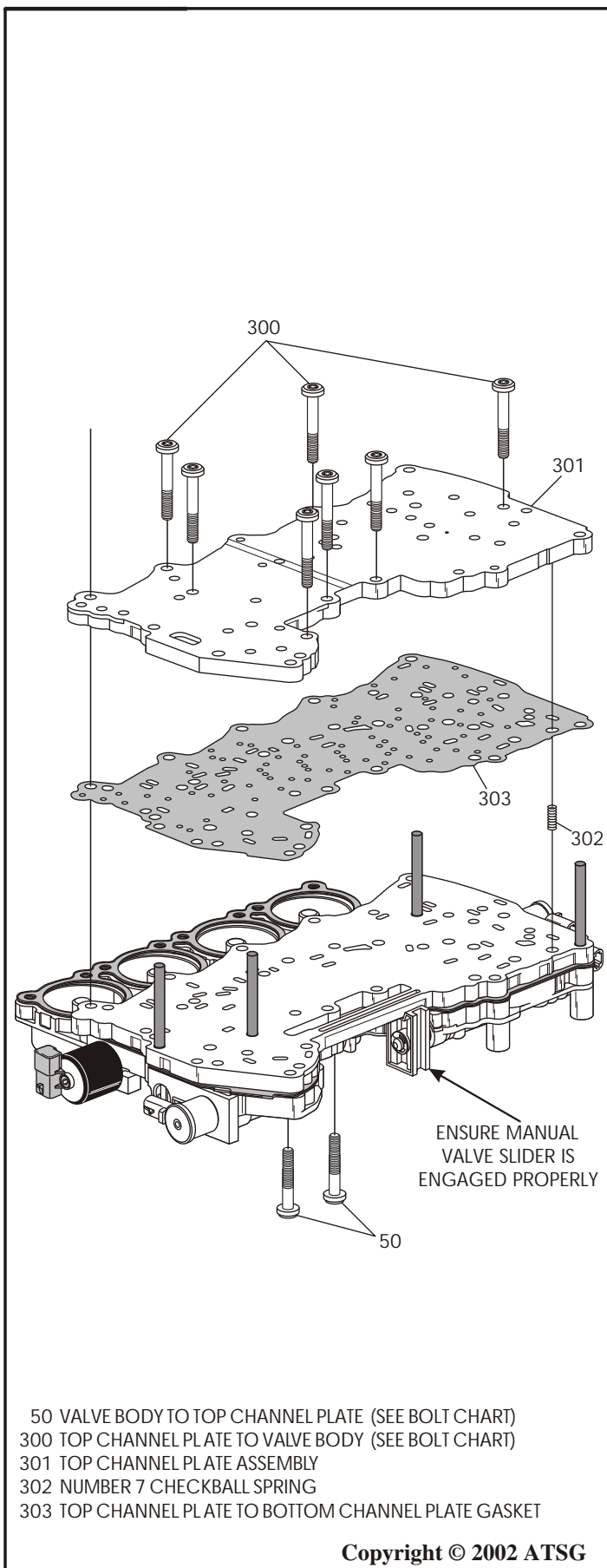

Figure 169

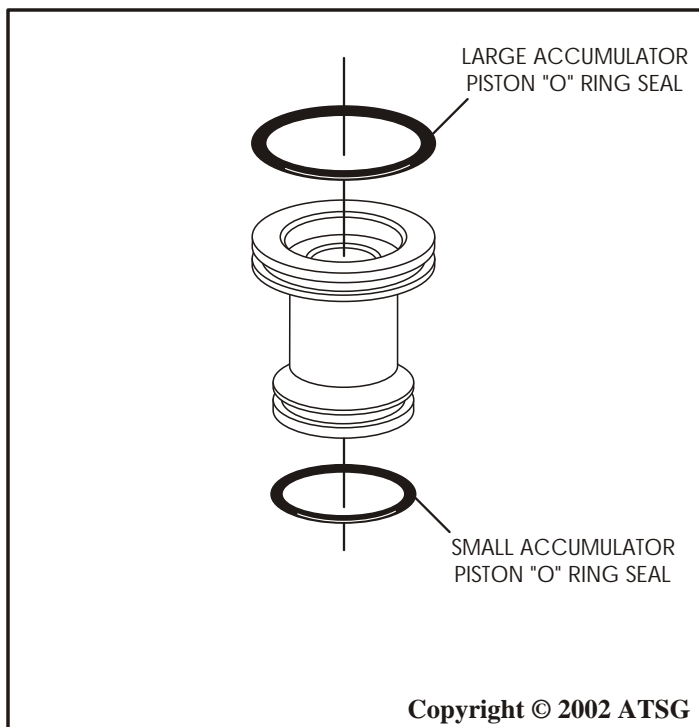

Figure 170

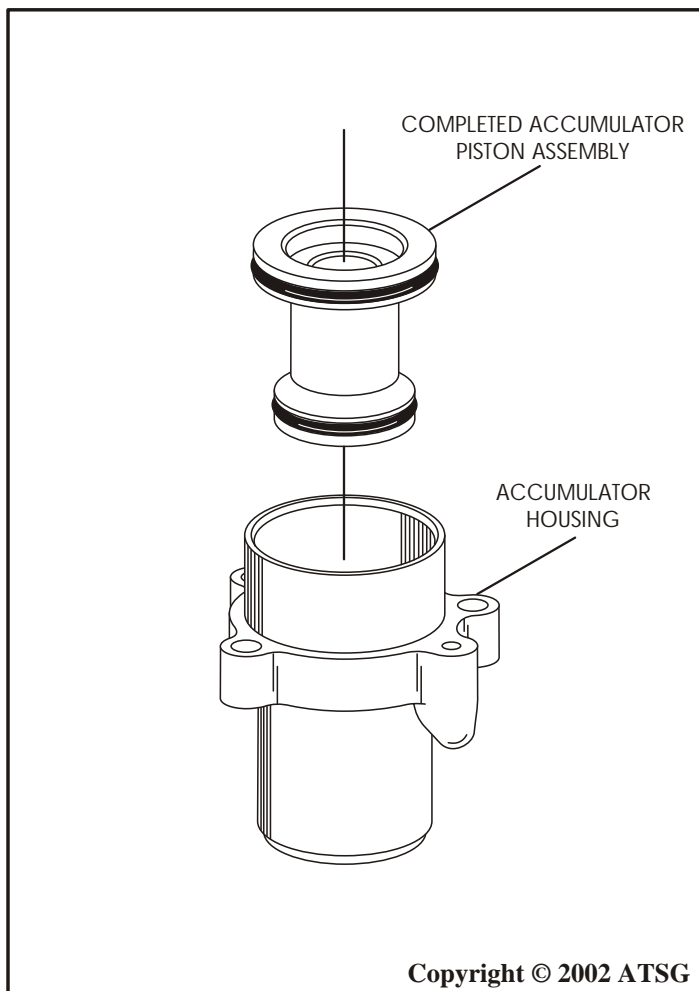

Figure 171



Technical Service Information

VALVE BODY ASSEMBLY (CONT'D)

24. Ensure that the manual valve slider is engaged properly with the lower channel plate casting, as shown in Figure 169.

Note: *Manual valve must slide freely.*

25. Install the top channel plate to bottom channel plate gasket over the guide pins, as shown in Figure 169.

26. Install the number 7 checkball spring (302) in the location shown in Figure 169.

27. Install the top channel plate casting over guide pins, as shown in Figure 169.

28. Install the 7 top channel plate to valve body bolts in the locations shown in Figure 169, and finger tighten only at this time.

Note: *Refer to bolt chart for identification of valve body bolts and their length.*

29. Install the 2 valve body to top channel plate bolts from the bottom, as shown in Figure 169, and finger tighten only at this time.

Note: *Refer to bolt chart for identification of valve body bolts and their length.*

30. Now you can torque the 9 valve body bolts you have just installed to 11 Nm (8 ft.lb.), and then remove the J-39068 guide pins.

Note: *Once again, ensure that manual valve moves freely.*

31. Install new "O" ring seals onto all four of the accumulator pistons, as shown in Figure 170.

Note: *All accumulator pistons are the same.*

All large "O" ring seals are the same.

All small "O" ring seals are the same.

All accumulator housings are the same.

All accumulator springs are the same.

32. Install the completed accumulator pistons into the accumulator housings (See Figure 171).

33. Install all completed accumulator assemblies onto the valve body assembly, using three bolts per accumulator, as shown in Figure 172.

34. Torque all four of the accumulator housings to 11 Nm (8 ft.lb.).

35. Set the completed valve body assembly, as shown in Figure 173, aside for final assembly.

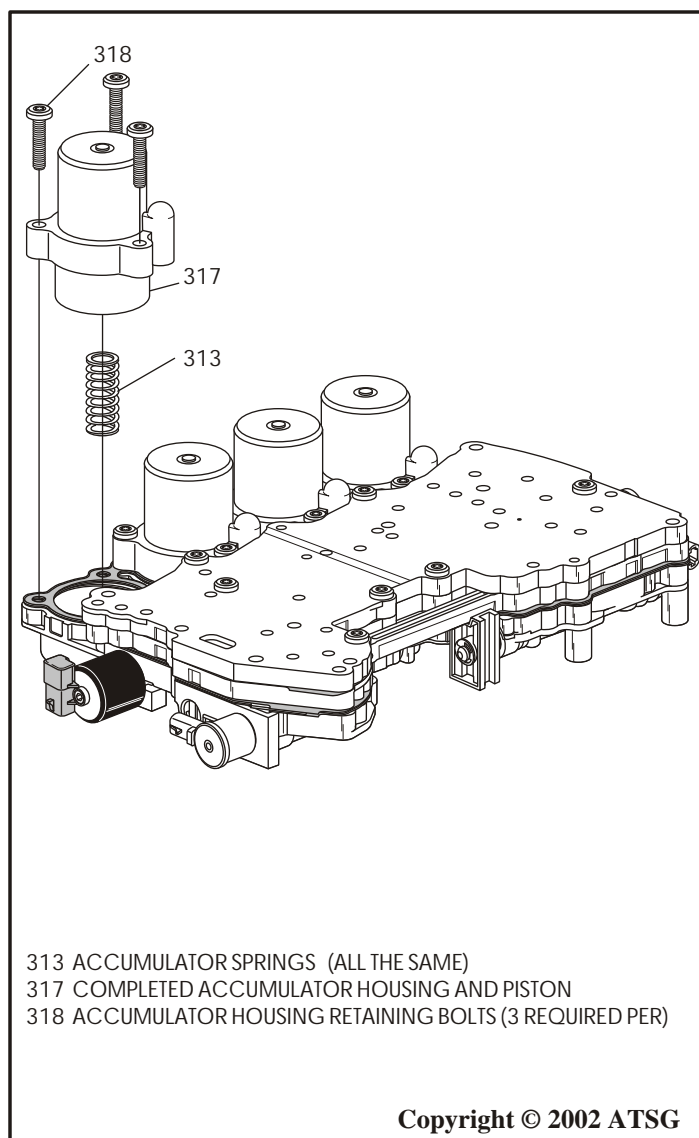

Figure 172

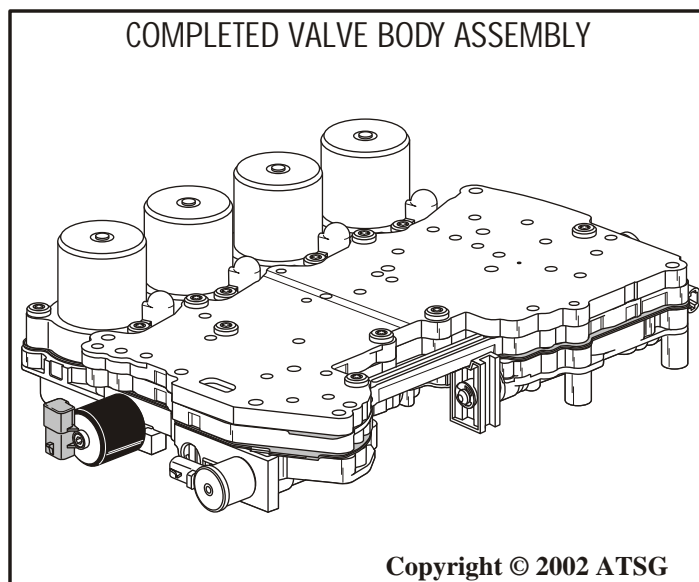

Figure 173



Technical Service Information

TRANSMISSION ASSEMBLY

INTERNAL COMPONENTS

1. Install the pre-assembled planetary internal ring gear and output shaft, along with the thrust bearing, as shown in Figure 174.

Note: We have illustrated both the 4L40-E and the 5L40-E in Figure 174.

2. Install pre-assembled planetary carrier system, as shown in Figure 175, by rotating down into position.

Note: We have illustrated both the 4L40-E and the 5L40-E in Figure 175.

3. Install pre-assembled center support assembly as shown in Figure 176, and rotate the output shaft back and forth to engage the 2nd clutch plates and the 2nd coast clutch plates.
4. Install thrust bearing on the back side of the low sprag assembly and retain with a small amount of Trans-Jel® (See Figure 177).
5. Install the low sprag assembly until fully seated by rotating back and forth to engage the low/reverse clutch plates (See Figure 177).

Continued on Page 109

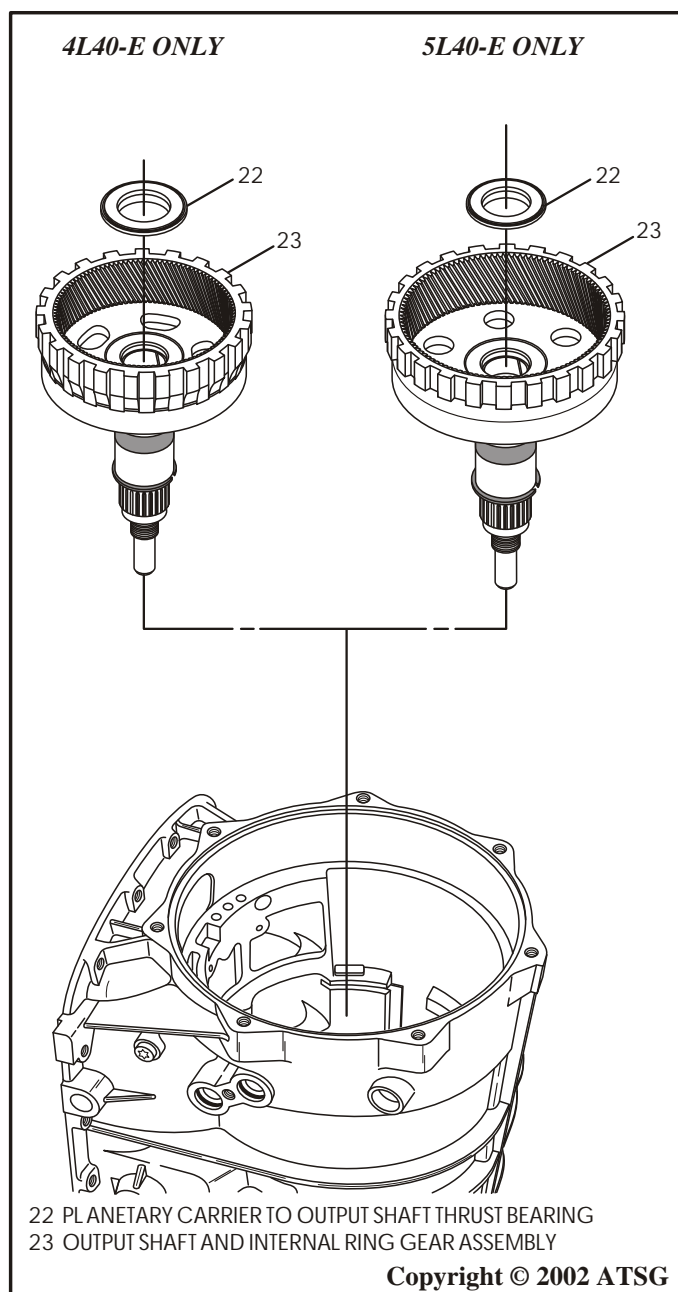

Figure 174

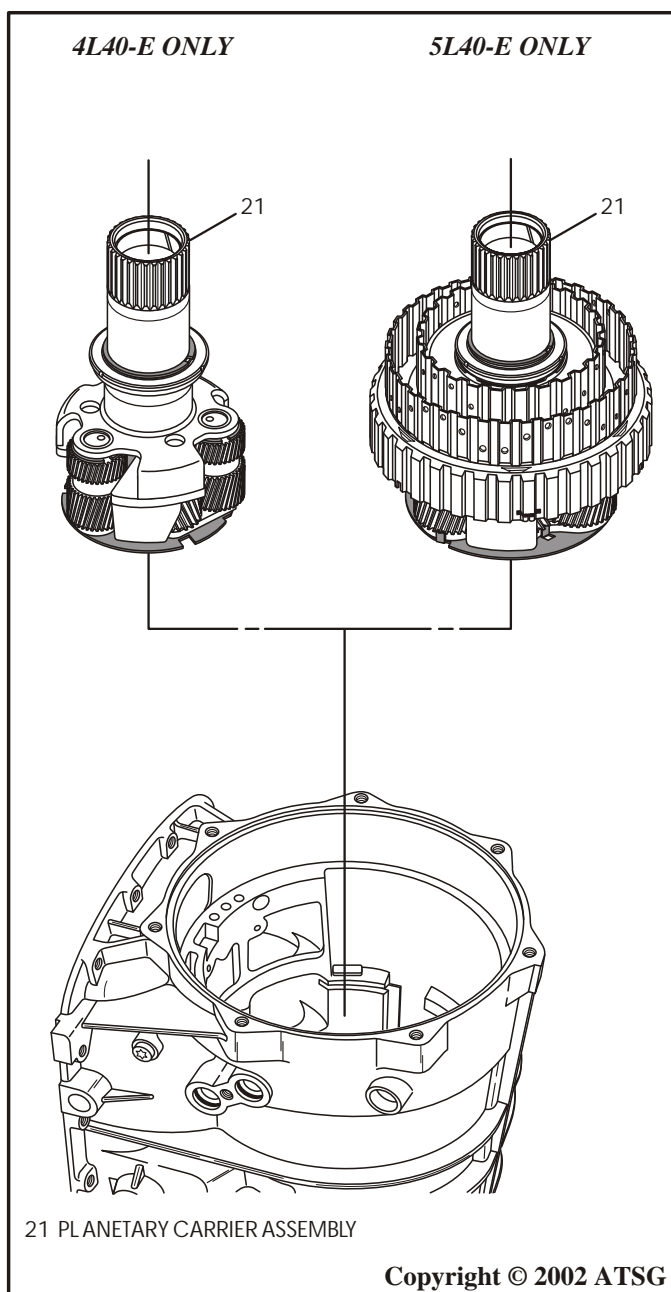

Figure 175



Technical Service Information

TRANSMISSION ASSEMBLY (CONT'D) INTERNAL COMPONENTS

6. Install pre-assembled intermediate/overdrive clutch housing, as shown in Figure 178. Rotate the output shaft back and forth until it is fully seated and engaged on the low sprag race.
7. **"Do Not" install the snap ring yet. This snap ring is "Selective" and we must measure to determine correct thickness.**

Continued on Page 110

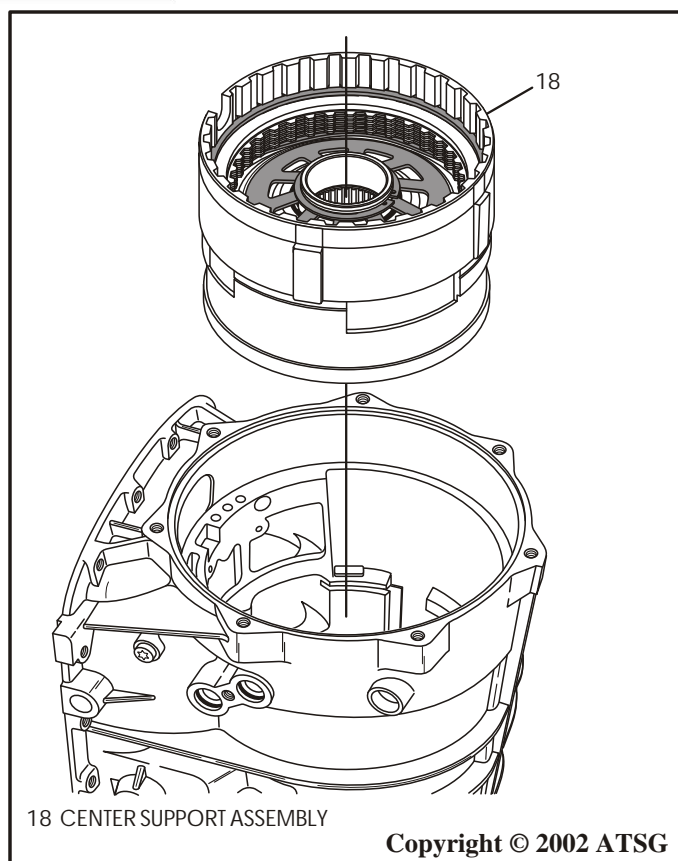

Figure 176

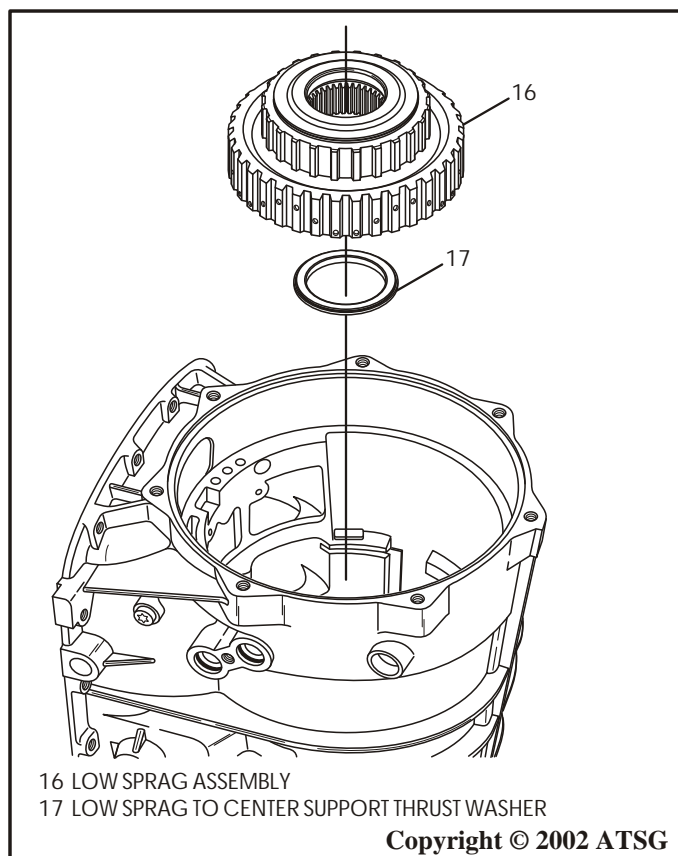

Figure 177

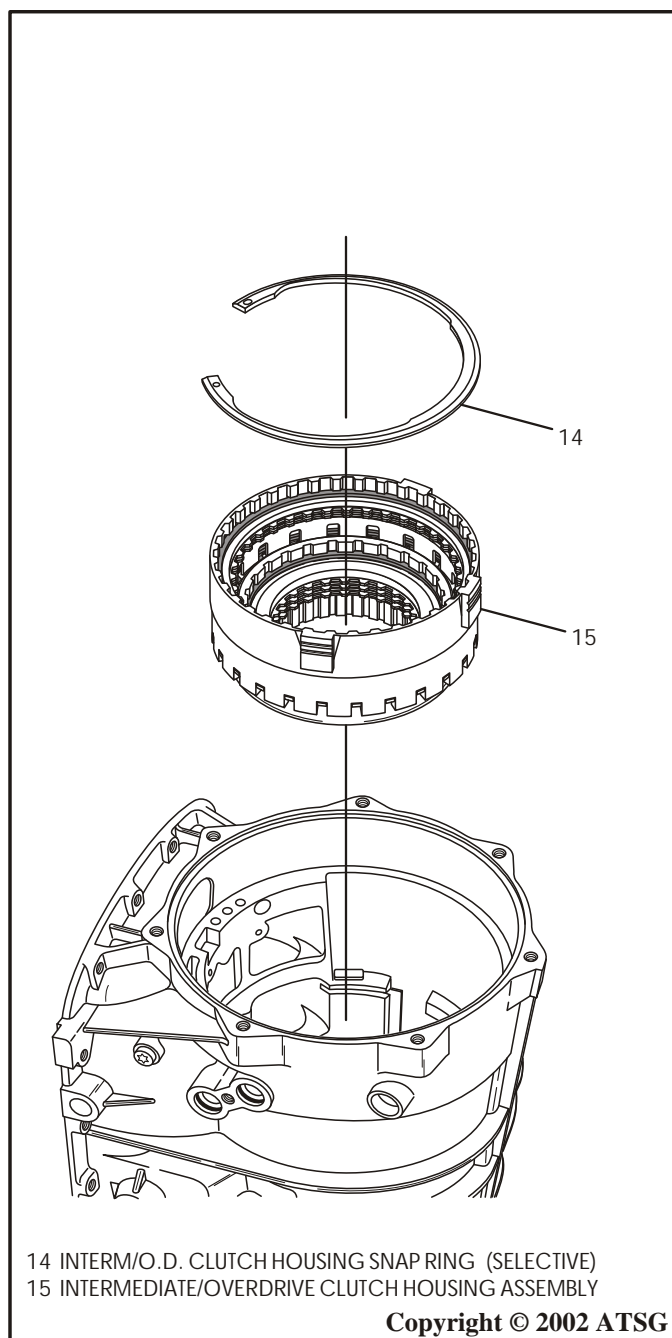

Figure 178



Technical Service Information

TRANSMISSION ASSEMBLY (CONT'D) INTERNAL COMPONENTS (CONT'D)

8. Measure the distance from the pump gasket surface, to the top of the intermediate/overdrive housing, as shown in Figures 179 and 180.
Note: Record this as Dimension "M1".
9. Measure the distance from the pump gasket surface, to the bottom of the snap ring groove in the case, as shown in Figures 179 and 180.
Note: Record this as Dimension "M2".

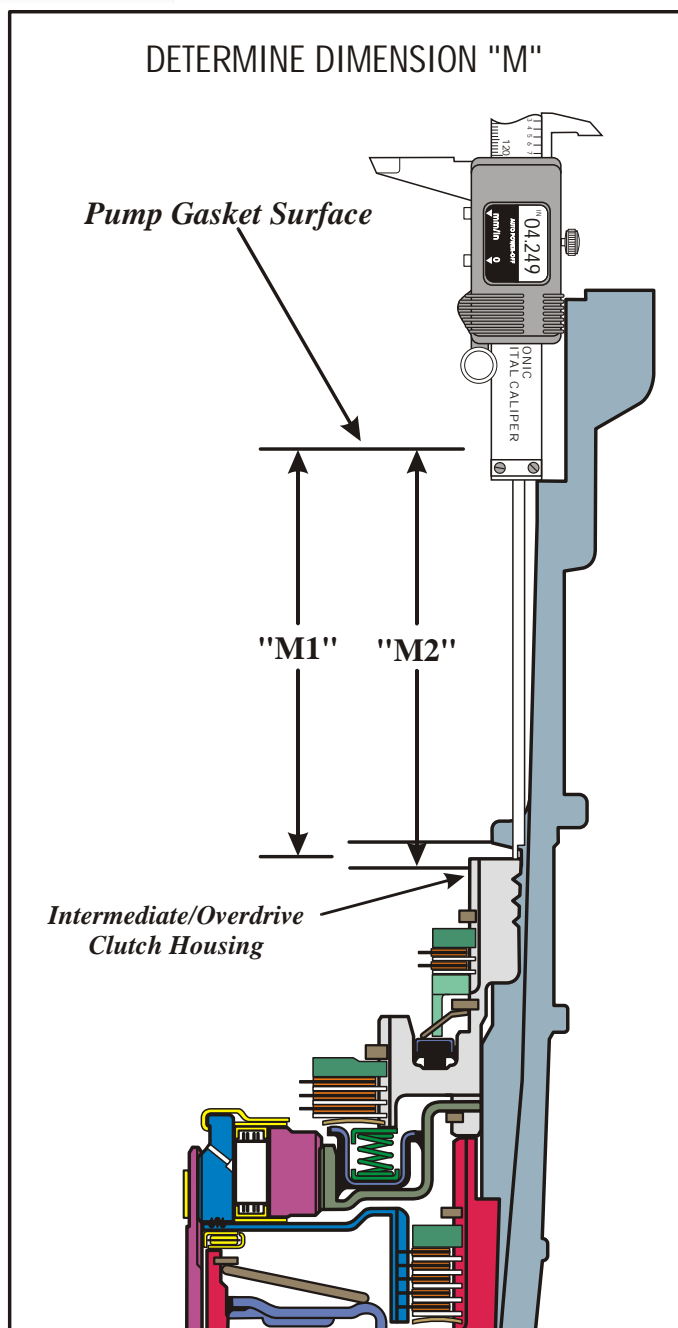

Figure 179

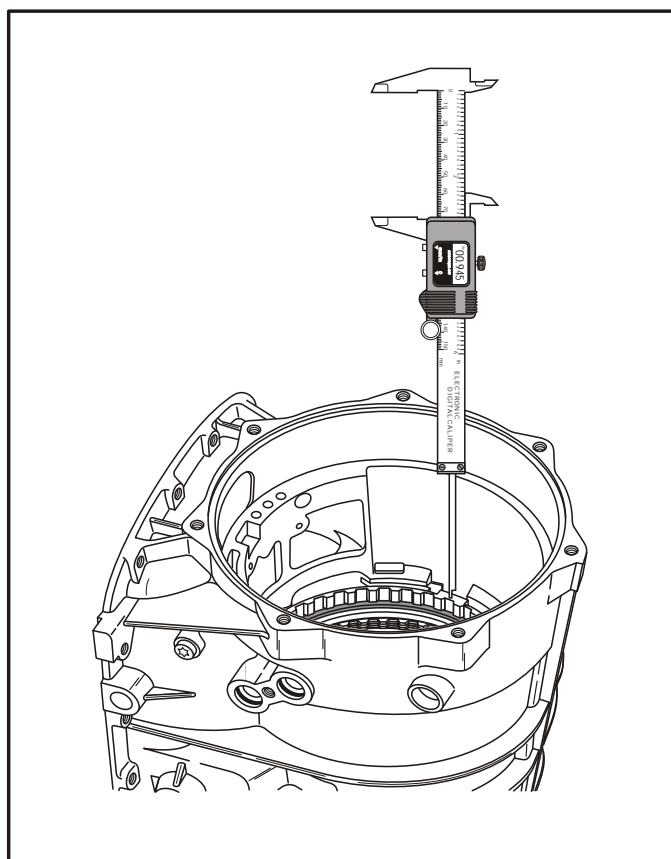

Figure 180

INTERMEDIATE AND OVERDRIVE CLUTCH HOUSING SNAP RING CHART	
DIMENSION "M"	SNAP RING THICKNESS SHOULD BE:
0.75 mm (.029") to .085 mm (.033")	3.90 to 4.00mm (.153" to .157")
0.85 mm (.033") to .095 mm (.037")	3.80 to 4.90mm (.149" to .153")
0.95 mm (.037") to 1.05 mm (.041")	3.70 to 3.80mm (.145" to .149")
1.05 mm (.041") to 1.15 mm (.045")	3.60 to 3.70mm (.141" to .145")
1.15 mm (.045") to 1.25 mm (.049")	3.50 to 3.60mm (.137" to .141")
1.25 mm (.049") to 1.35 mm (.054")	3.40 to 3.50mm (.133" to .137")

Figure 181

INTERNAL COMPONENTS (CONT'D)

10. After you have both dimensions recorded, subtract "M1" from "M2".
Note: This will be Dimension "M".
11. Refer to the chart in Figure 181 to determine the thickness of the proper snap ring.
12. Measure thickness of your snap ring *exactly* as shown in Figure 182, to ensure that your snap ring is the proper thickness.

EXAMPLE:

1. Dimension "M1" = 4.206".
 2. Dimension "M2" = 4.249".
 3. Subtract "M1" from "M2" = .043".
 4. Dimension "M" = .043"
 5. Dimension "M" from the chart in Figure 181 shows a .141"-.145" thickness snap ring required.
13. Now you can install the proper size snap ring using the J-45126 snap ring pliers, as shown in Figure 183.
Note: This snap ring is "Very" strong and requires J-45126 snap ring pliers to avoid any possible injury.

Continued on Page 112

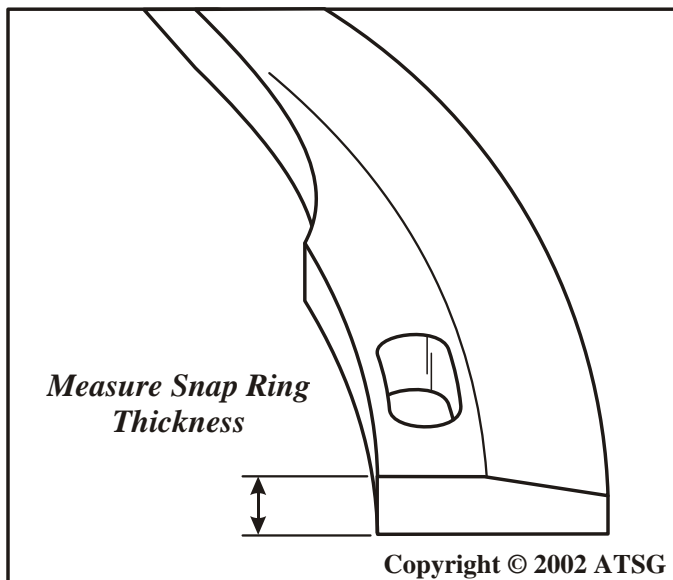

Figure 182

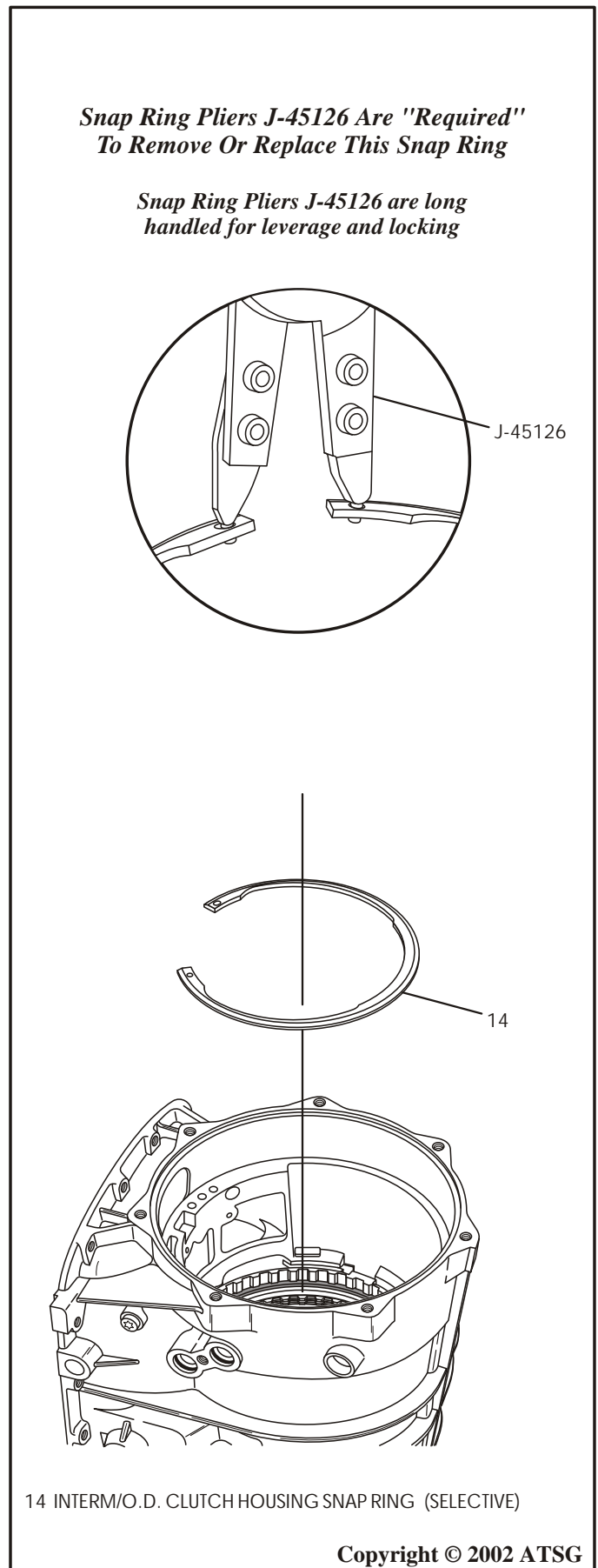

Figure 183

TRANSMISSION ASSEMBLY (CONT'D)

INTERNAL COMPONENTS (CONT'D)

14. Install thrust washer (11) onto the overdrive clutch hub and intermediate sprag assembly as shown in Figure 184, if not already done, and retain with small amount of Trans-Jel®.
15. Install overdrive clutch hub and intermediate sprag assembly, as shown in Figure 184, by rotating back and forth until fully seated and both overdrive and 2nd clutches are engaged.
16. Install direct clutch hub thrust washer (9) into direct clutch hub, as shown in Figure 185, if not already done, and retain with small amount of Trans-Jel®.

17. Install the direct clutch hub assembly into the transmission, as shown in Figure 185, by rotating back and forth until fully seated.
18. Install the pre-assembled forward sprag and sun gear shaft assembly into the transmission, as shown in Figure 186, by rotating back and forth until fully seated.

Continued on Page 113

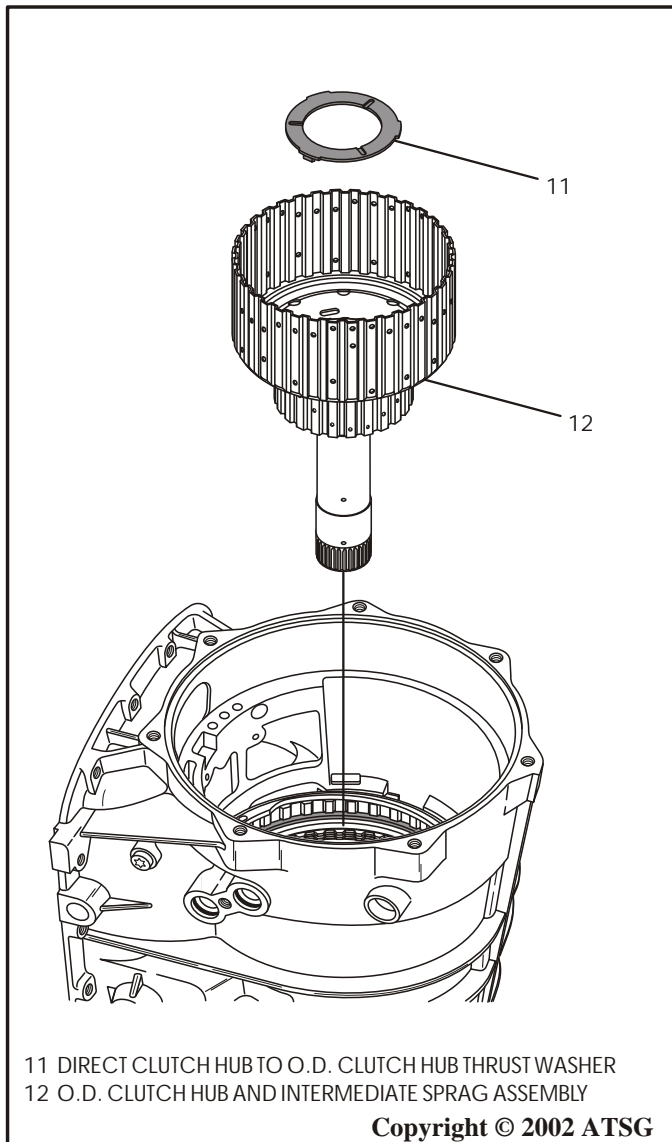

Figure 184

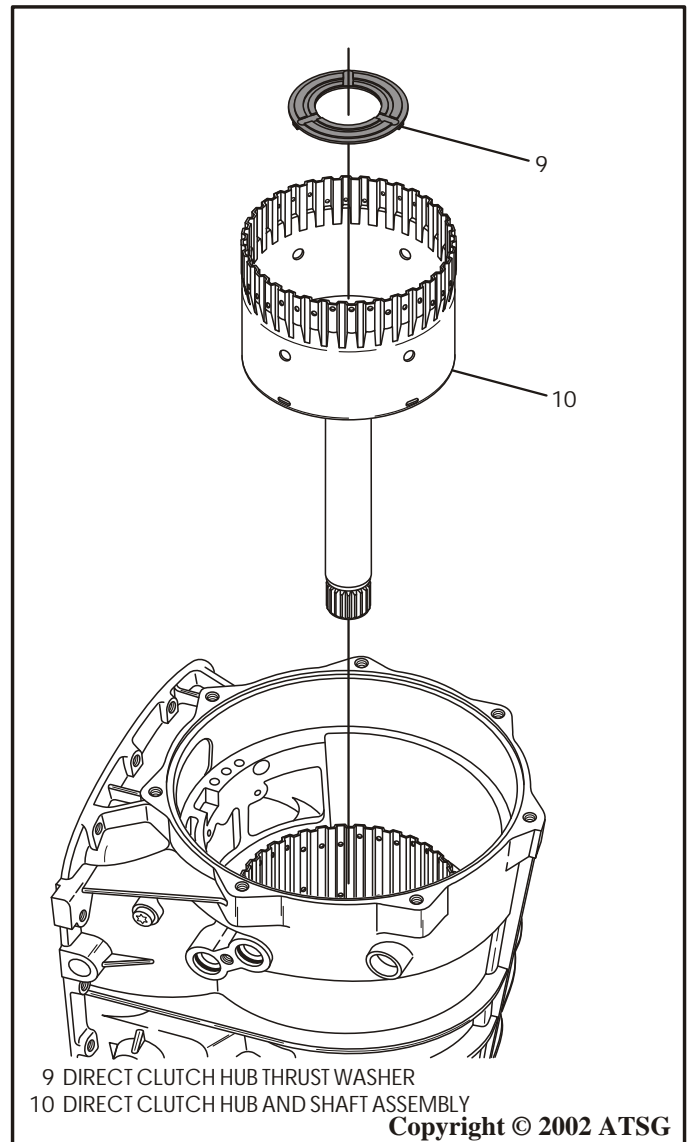

Figure 185

INTERNAL COMPONENTS (CONT'D)

19. Install the reverse clutch housing on forward and coast clutch housing by rotating back and forth to engage the reverse clutch plates, until fully seated and splines engaged on forward clutch housing (See Figure 187).

Continued on Page 114

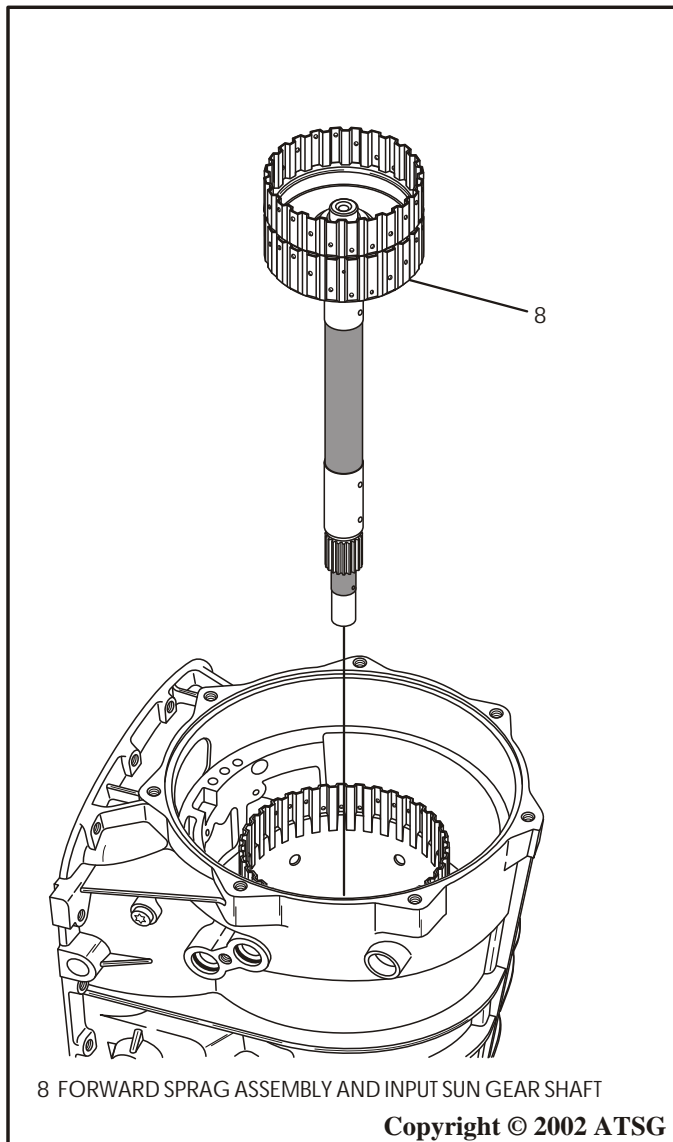

Figure 186

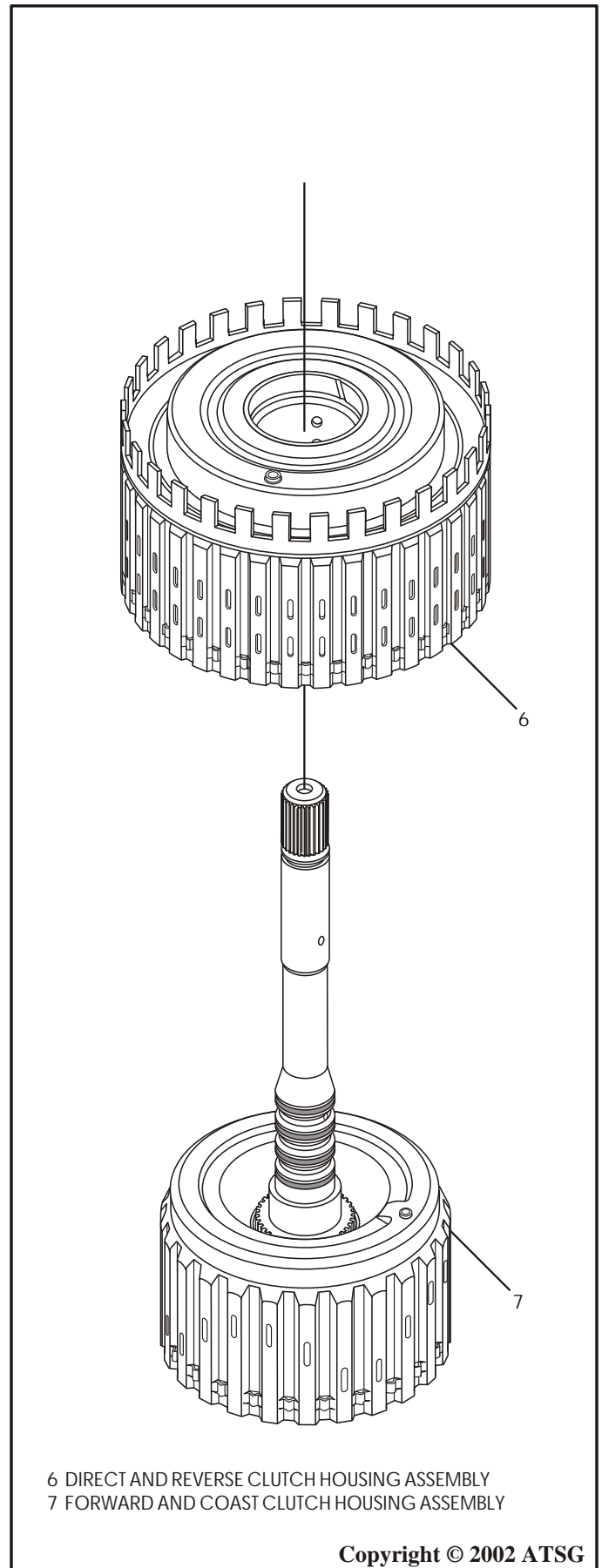

Figure 187



Technical Service Information

TRANSMISSION ASSEMBLY (CONT'D)

INTERNAL COMPONENTS (CONT'D)

20. Install the pre-assembled forward/coast clutch housing and reverse clutch housing as assembly as shown in Figure 188, by rotating back and forth to engage the three sets of clutches.
21. Install the "H" gage on top surface of the case, as shown in Figure 189, loosen adjusting knob and allow gage rod to rest on washer surface of reverse clutch housing (See Figure 189).
22. Remove "H" gage from case, turn it over and install on surface of converter housing as it is shown in Figure 190.
23. Measure with feeler gage between the gage rod and the current "Selective" thrust washer being used, as shown in Figure 190.
24. Front end clearance should be: 0.76 - 1.02 mm (.030" - .040"). Change the selective thrust washer as necessary to achieve the proper front end clearance.
25. Refer to chart in Figure 190 for the different thickness thrust washers that are available.

Continued on Page 115

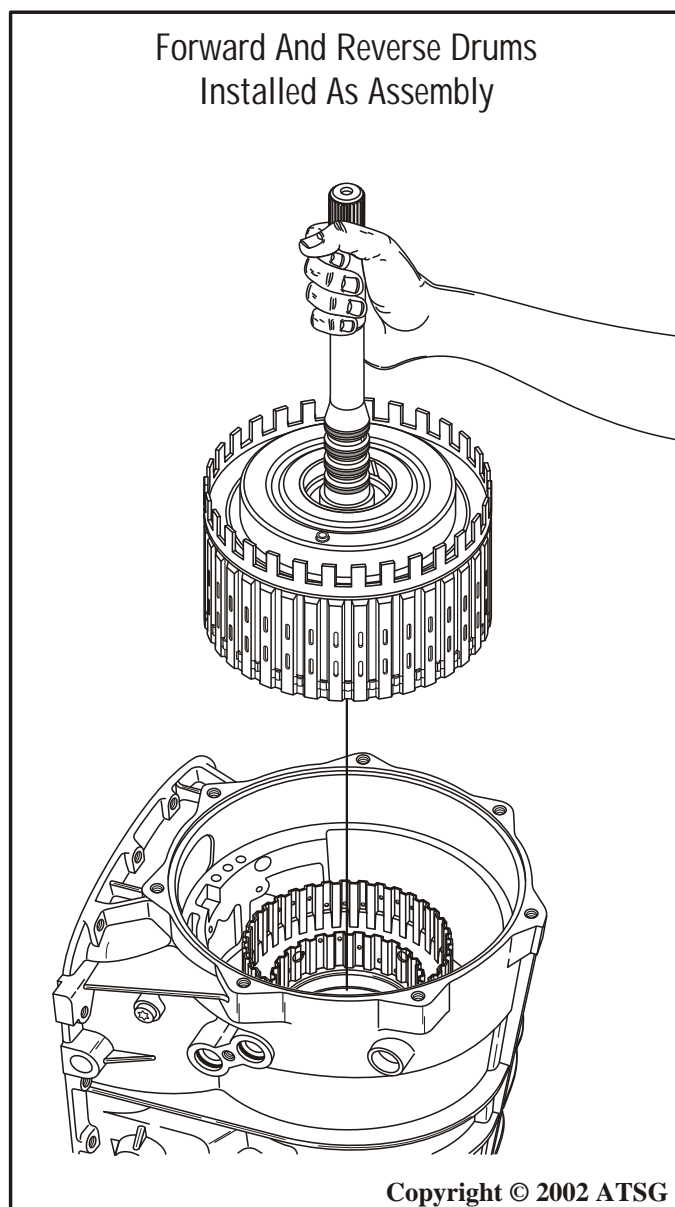

Figure 188

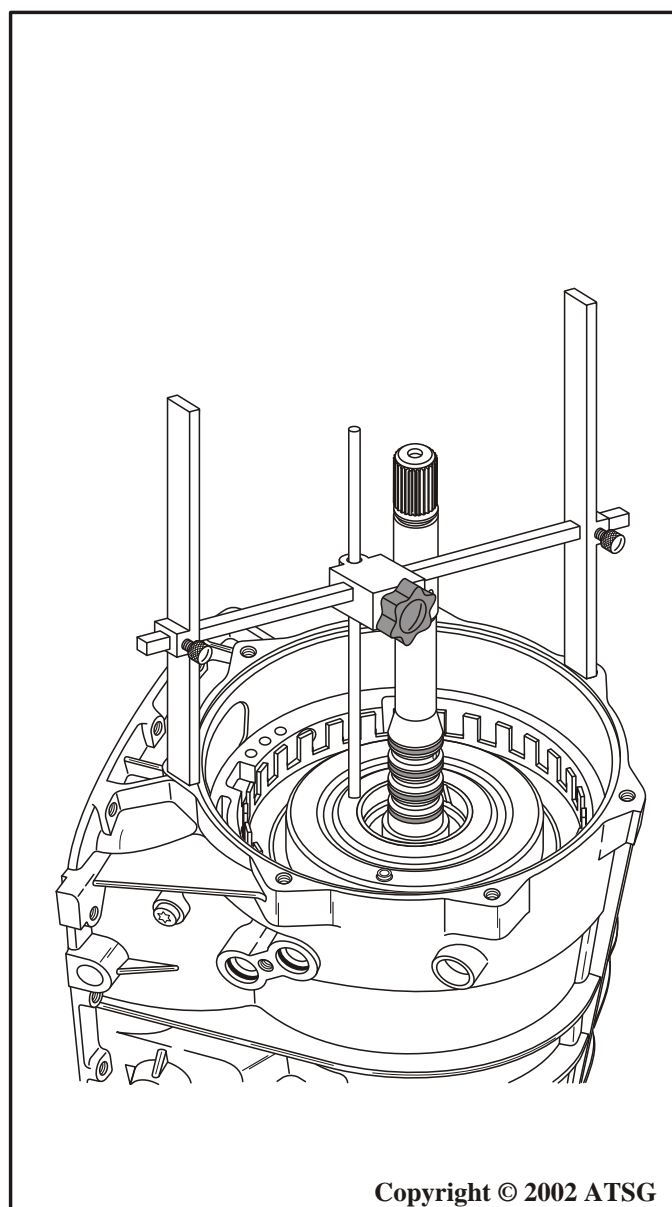

Figure 189



Technical Service Information

THRUST WASHERS AVAILABLE

2.53-2.68 mm (.099"-.105")

2.71-2.86 mm (.106"-.112")

2.89-3.04 mm (.113"-.119")

3.05-3.20 mm (.120"-.125")

3.25-3.40 mm (.127"-.133")

3.43-3.58 mm (.135"-.140")

3.61-3.76 mm (.142"-.148")

3.79-3.94 mm (.149"-.155")

CHECKING FRONT END CLEARANCE
CLEARANCE SHOULD BE .030" TO .040"

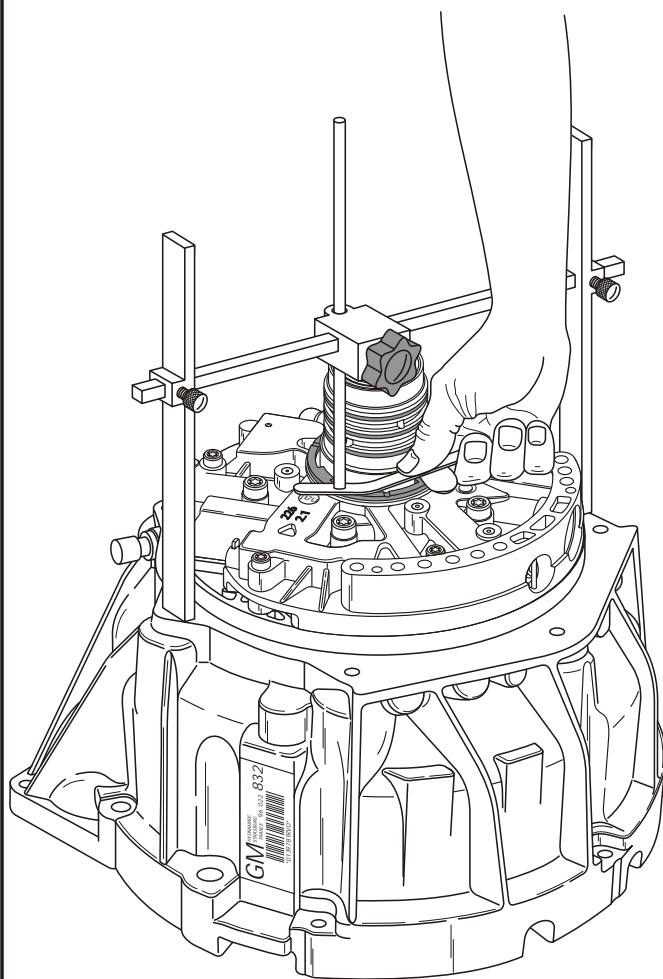

Copyright © 2002 ATSG

Figure 190

INTERNAL COMPONENTS (CONT'D)

26. Ensure that the converter housing to case "O" ring seal is in place on the converter housing. If not, install it now as shown in Figure 191 and retain with small amount of Trans-Jel®.

Continued on Page 116

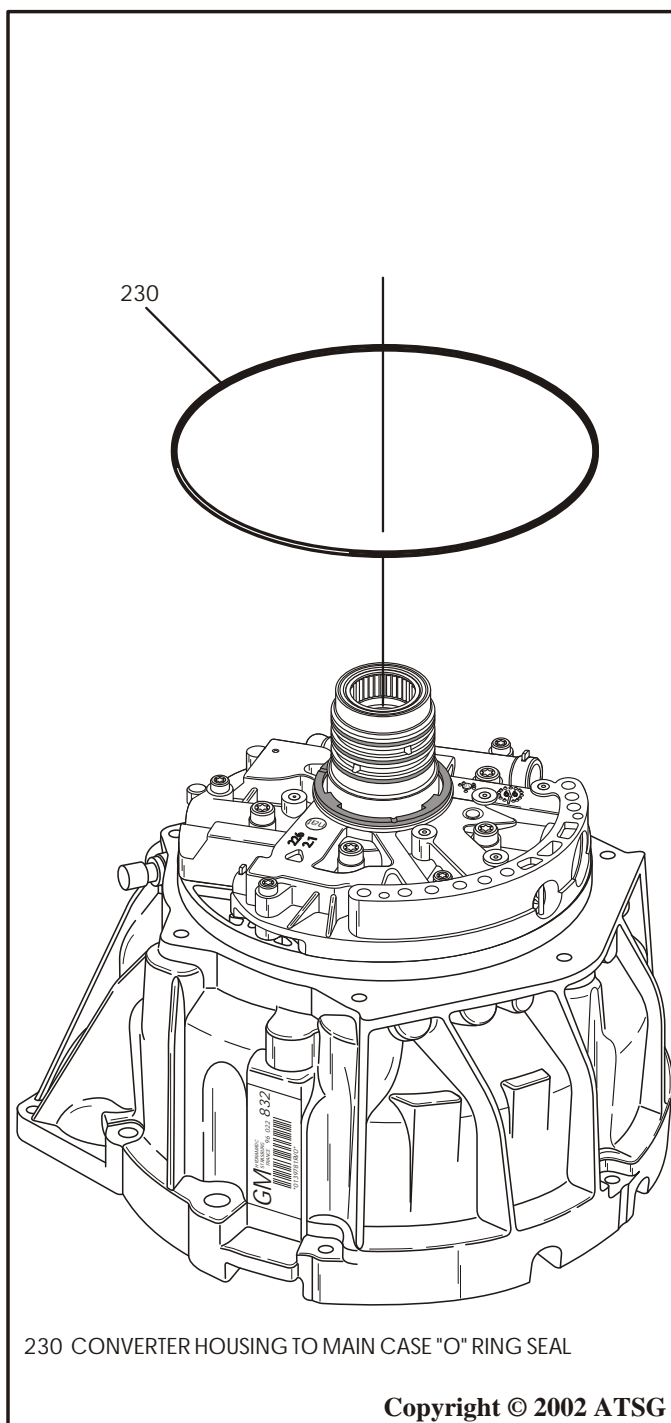

230 CONVERTER HOUSING TO MAIN CASE "O" RING SEAL

Copyright © 2002 ATSG

Figure 191



Technical Service Information

TRANSMISSION ASSEMBLY (CONT'D)

INTERNAL COMPONENTS (CONT'D)

27. Install the molded pump to case gasket (46) onto the back side of pump cover, as shown in Figure 192, using the molded guide pins.
28. Retain with a small amount of Trans-Jel®, if necessary.
29. Install complete converter housing assembly onto case, as shown in Figure 192.
30. Install the seven converter housing to case bolts, as shown in Figure 192. Refer to the bolt chart to identify proper bolts.
31. Torque the seven bolts to 22 Nm (16 ft.lb.), as shown in Figure 194.
32. Use the torque sequence in a criss-cross pattern, as shown in Figure 193.
33. Install the turbine shaft "O" ring seal using a small screwdriver, as shown in Figure 195, and lubricate with small amount of Trans-Jel®.

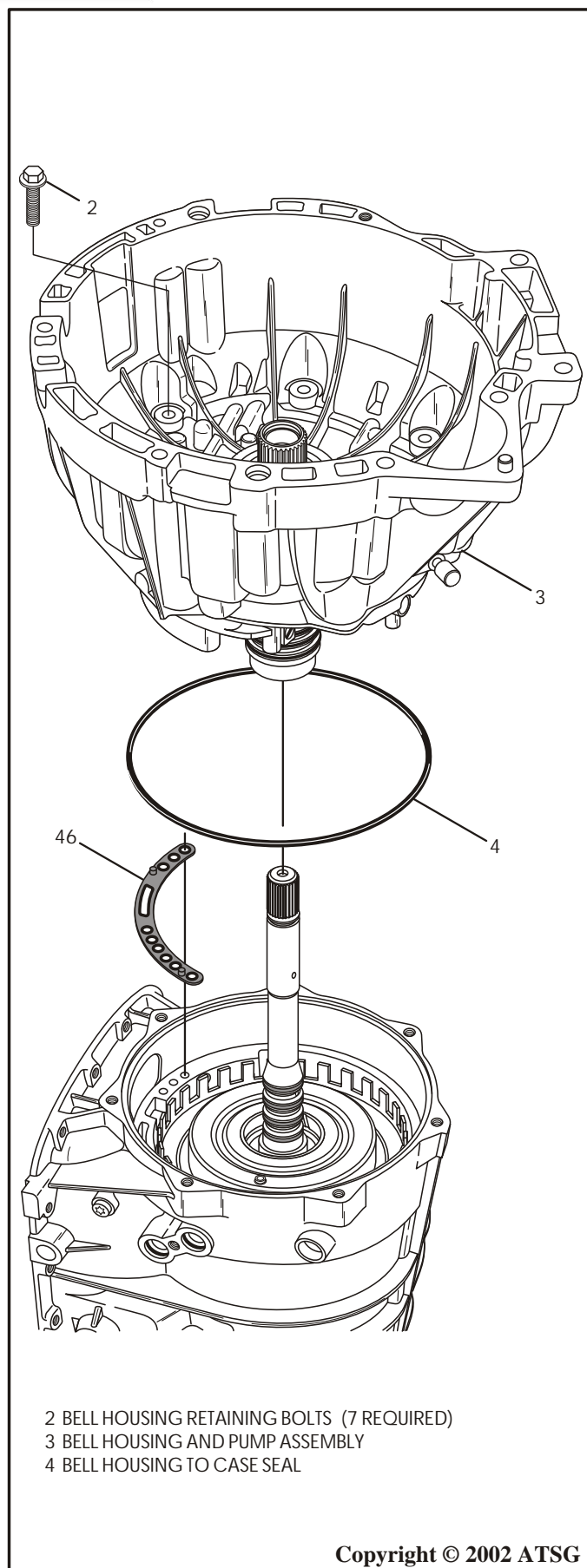

Figure 192

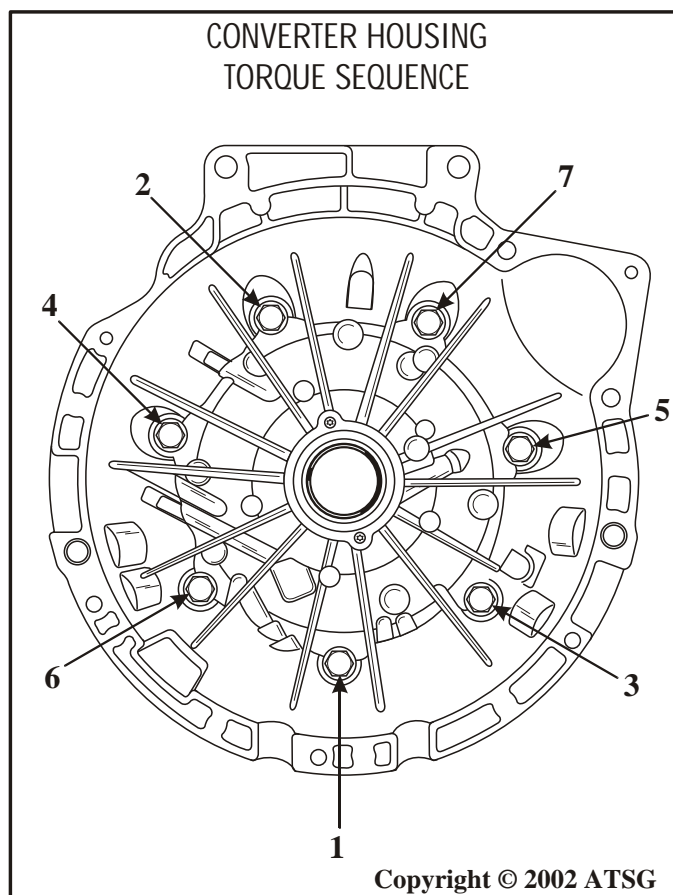
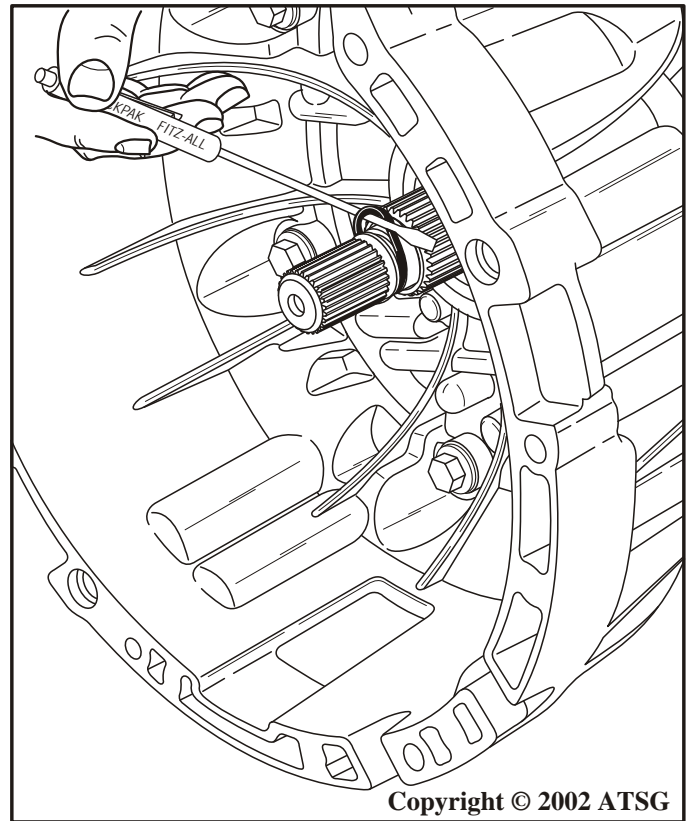

Figure 193

INTERNAL COMPONENTS (CONT'D)

34. Rotate the transmission in fixture so that the bottom pan side is facing up, as shown in Figure 196.
35. Install the valve body to case seal assemblies, as shown in Figure 196.

Continued on Page 118



Copyright © 2002 ATSG

Figure 195

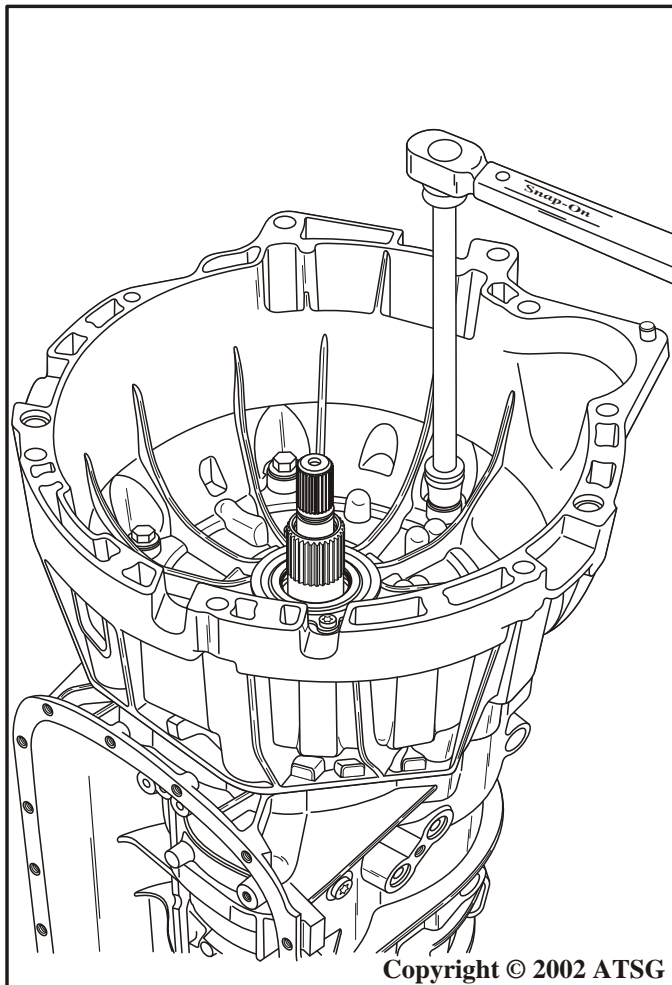

Copyright © 2002 ATSG

Figure 194

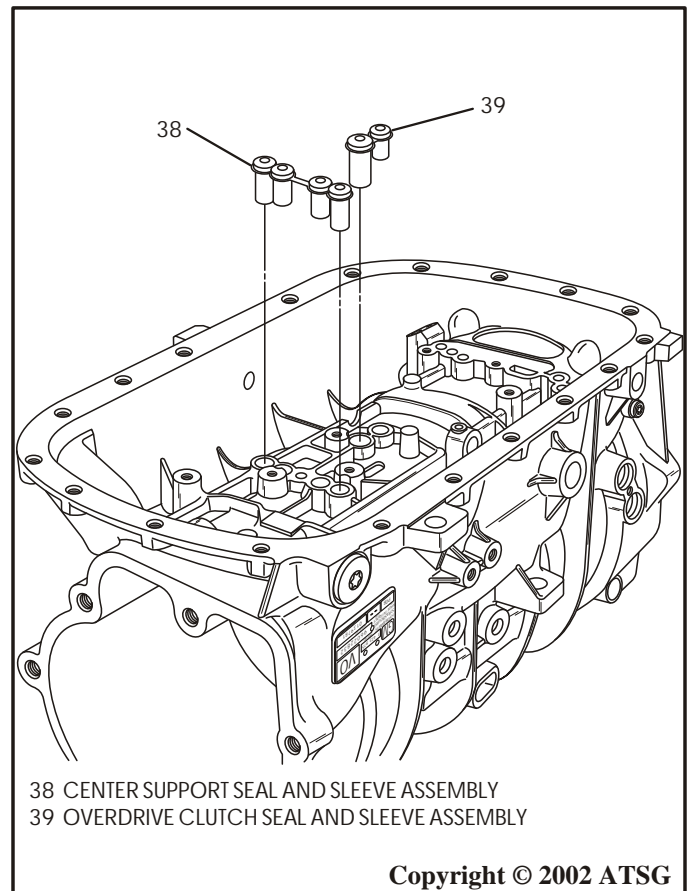

38 CENTER SUPPORT SEAL AND SLEEVE ASSEMBLY
39 OVERDRIVE CLUTCH SEAL AND SLEEVE ASSEMBLY

Copyright © 2002 ATSG

Figure 196



Technical Service Information

TRANSMISSION ASSEMBLY (CONT'D)

BOTTOM PAN COMPONENTS

1. Install the input shaft speed sensor, as shown in Figure 197.
2. Torque the input shaft speed sensor bolt down to 11 Nm (8 ft.lb.).
Note: Refer to the bolt chart to identify the proper bolt.
3. Install the output shaft speed sensor, as shown in Figure 198.
4. Torque the output shaft speed sensor bolt down to 11 Nm (8ft.lb.).
Note: Refer to the bolt chart to identify the proper bolt.
5. Install the pre-assembled valve body assembly onto case, as shown in Figure 199.
6. Install the proper bolts installed in the locations shown in Figure 199 and 201, and hand tighten only at this time.
Note: Refer to the bolt chart to identify the proper valve body bolts.
7. Install a 0.8 mm spacer between inside detent lever and the detent spring, as shown in Figure 200.
8. Torque all ten valve body bolts, in the exact sequence shown in Figure 201, down to 11 Nm (8 ft.lb.).
9. Remove the 0.8 mm spacer.

Continued on Page 120

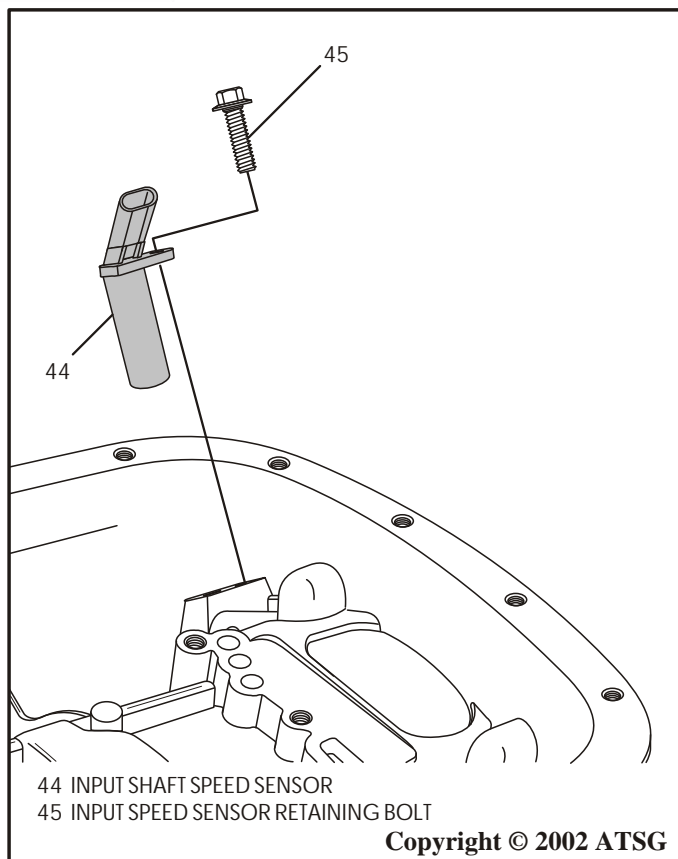

Figure 197

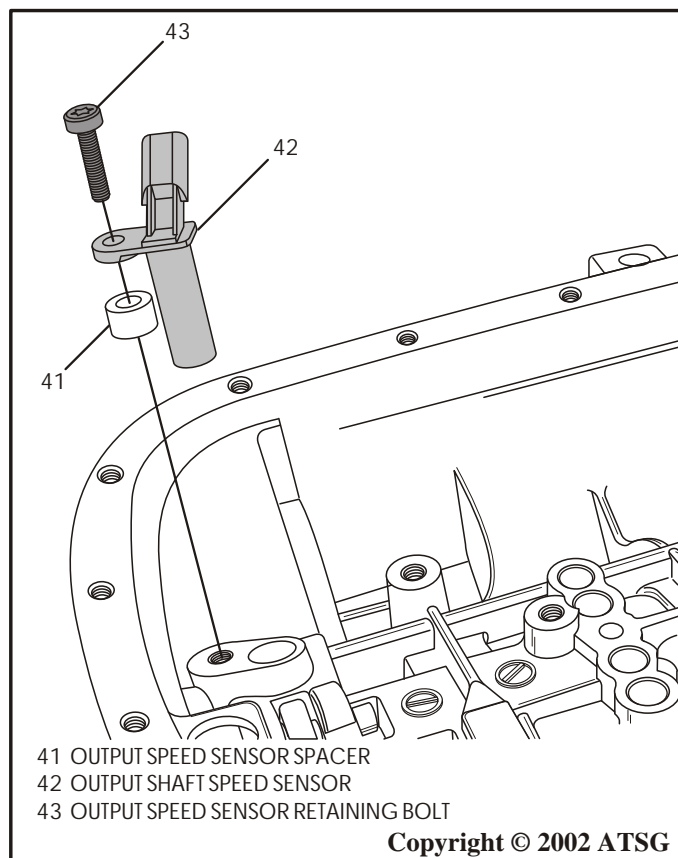

Figure 198



Technical Service Information

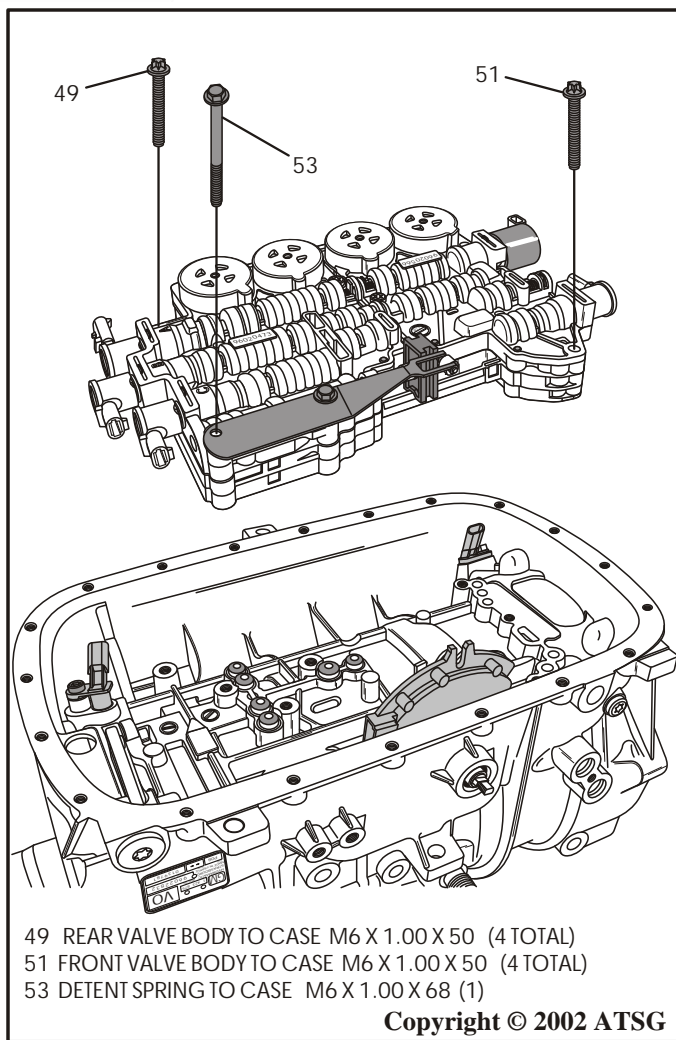

Figure 199

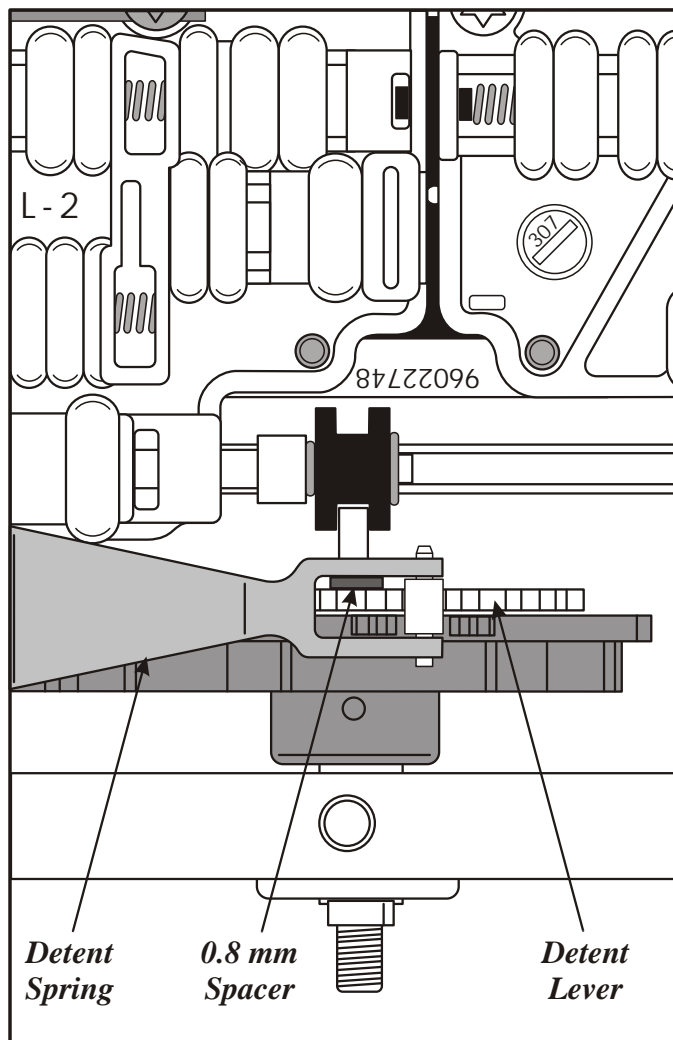

Figure 200

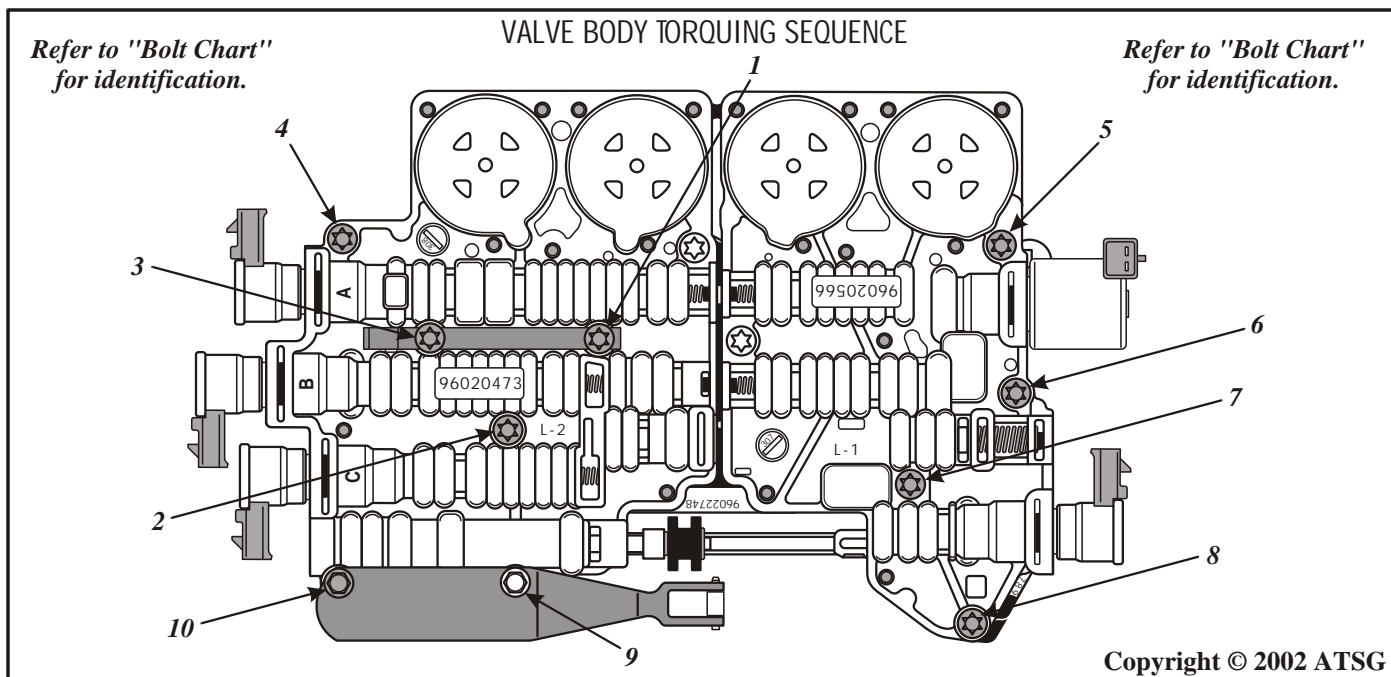

Figure 201

TRANSMISSION ASSEMBLY (CONT'D)

BOTTOM PAN COMPONENTS (CONT'D)

10. Install two new "O" ring seals onto the case connector, as shown in Figure 202, and lube with a small amount of Trans-Jel®.
11. Install the case connector through the case bore and while holding the connector, install the retaining clip, as shown in Figure 203.
12. Route the internal harness and connect all the components that are listed in Figure 202.
13. Install the TFT Sensor into the TFT Sensor bracket (See Figure 202).
14. Install the bottom pan filter, filter seals and the filter spacer, as shown in Figure 204.
15. Install a new bottom pan gasket onto the transmission case, as shown in Figure 205.
16. Ensure that the bottom pan magnet is in proper position in the oil pan (See Figure 205).
17. Install the bottom transmission pan onto the transmission, as shown in Figure 205.
18. Ensure that internal wiring harness is not rubbing on any part of the oil pan, as you put it on the case.
19. Install the 20 bottom oil pan bolts, as shown in Figure 205, and torque to 11 Nm (8 ft.lb.).

Note: Notice that spacer is used only on "Some" models.

Continued on Page 122

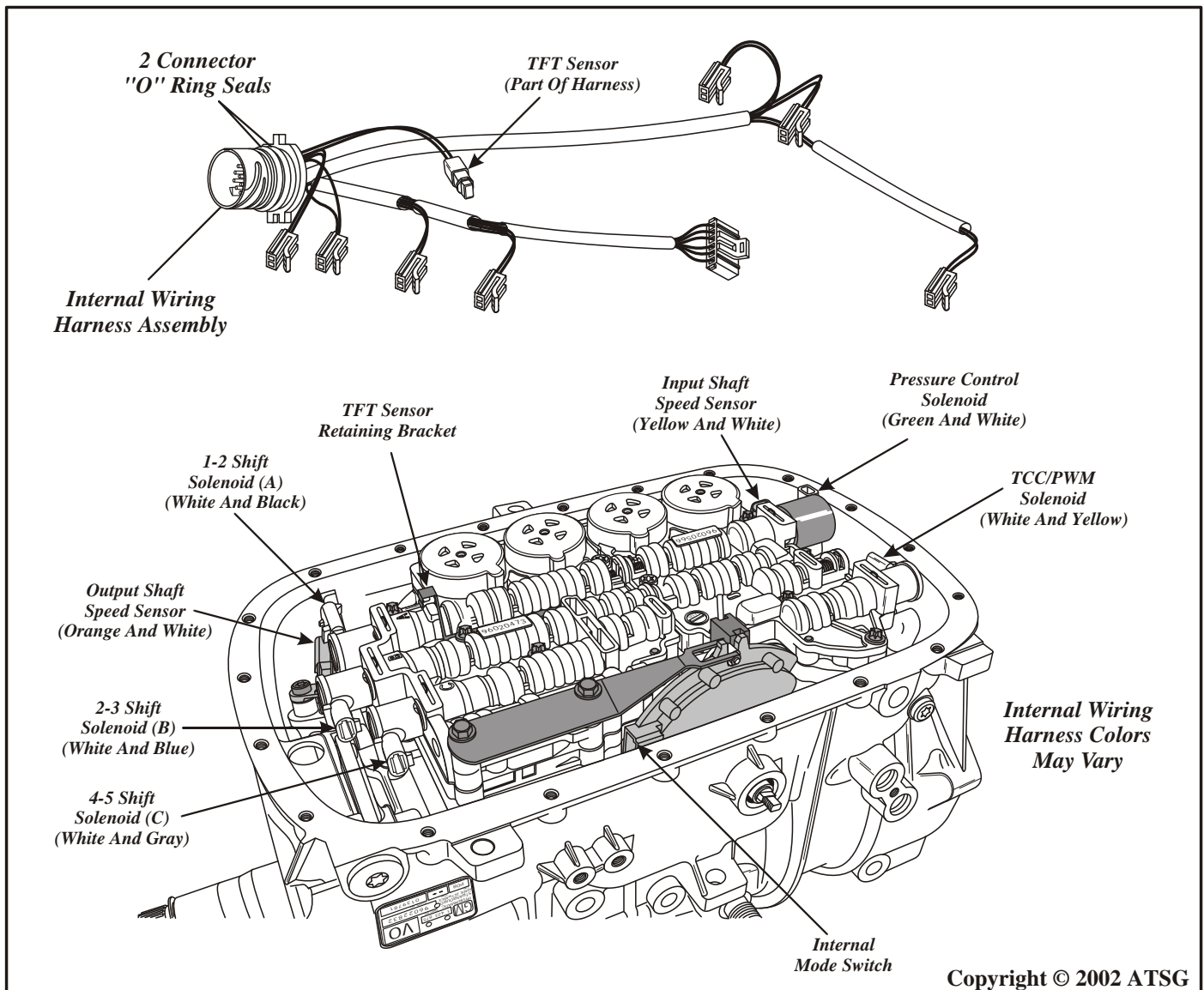
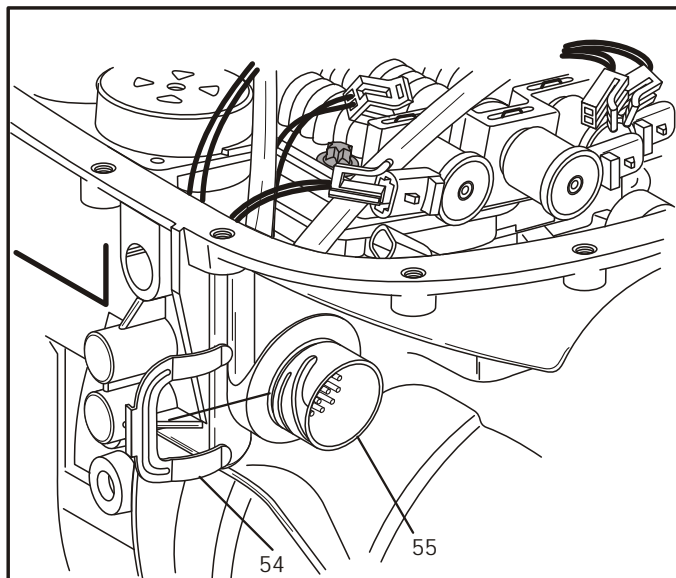

Figure 202



Technical Service Information



- 54 TRANSMISSION CASE CONNECTOR RETAINER
- 55 TRANSMISSION CASE CONNECTOR

Copyright © 2002 ATSG

Figure 203

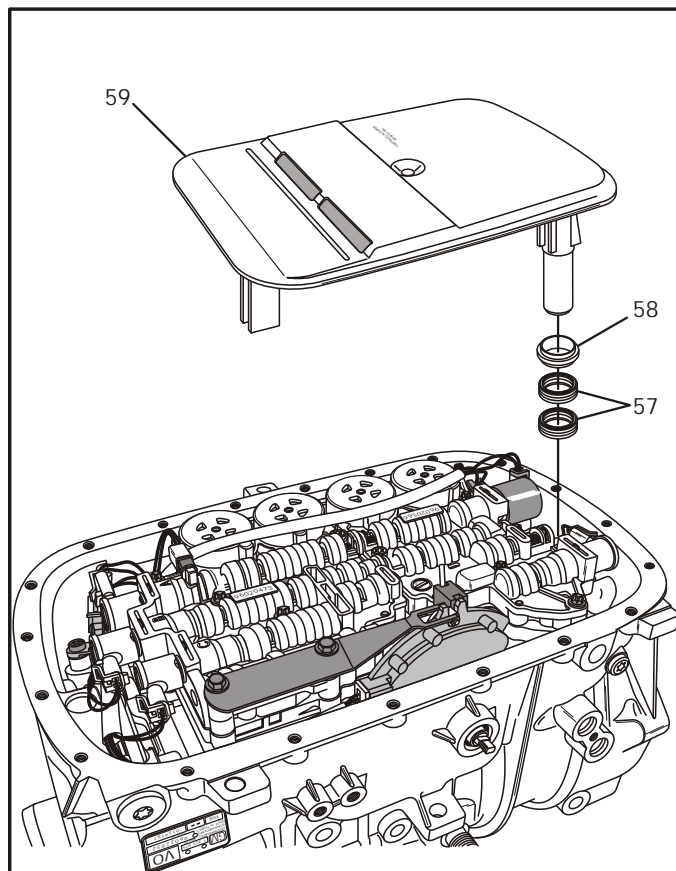

- 57 BOTTOM PAN OIL FILTER SEALS
- 58 BOTTOM PAN OIL FILTER SPACER (SOME MODELS)
- 59 BOTTOM PAN OIL FILTER ASSEMBLY

Copyright © 2002 ATSG

Figure 204

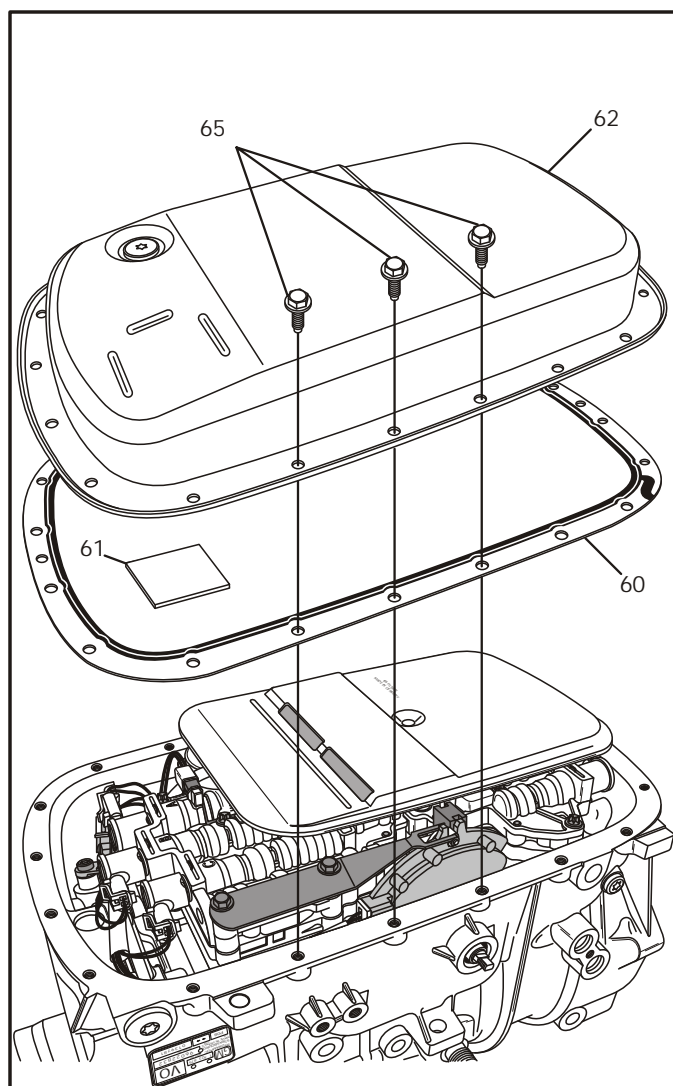

- 60 BOTTOM OIL PAN GASKET
- 61 BOTTOM OIL PAN MAGNET
- 62 BOTTOM OIL PAN
- 65 BOTTOM OIL PAN BOLTS (20 REQUIRED)

Copyright © 2002 ATSG

Figure 205



Technical Service Information

TRANSMISSION ASSEMBLY (CONT'D) EXTERNAL COMPONENTS

1. Rotate transmission in fixture so that output shaft is facing up, as shown in Figure 207.

2. Install extension housing yoke seal into the extension housing, as shown in Figure 206, using the proper seal driver.

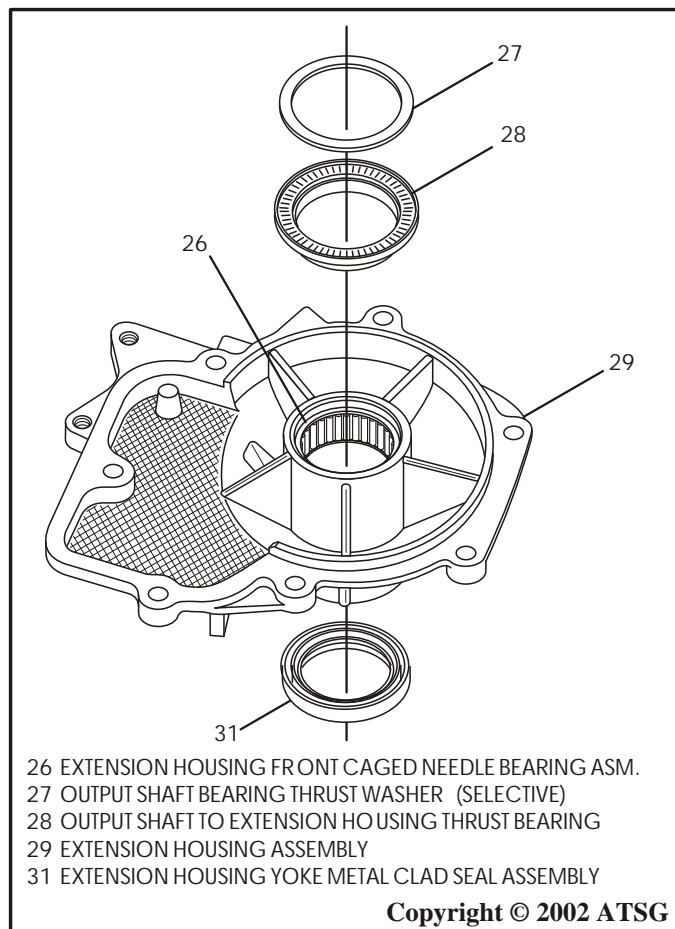

Figure 206

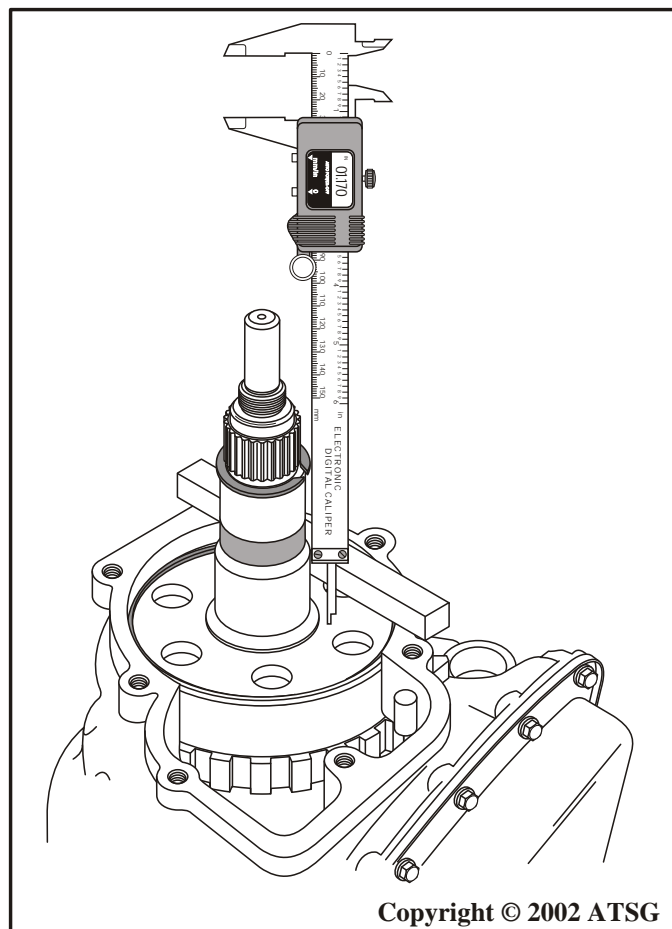

Figure 207

OUTPUT SHAFT END PLAY CHART	
IF DIMENSION "B" IS:	THRUST WASHER THICKNESS SHOULD BE:
<i>15.99 to 16.27 mm (.629" to .640")</i>	<i>0.95 to 1.05 mm (.037" to .041")</i>
<i>16.27 to 16.47 mm (.640" to .648")</i>	<i>1.15 to 1.25 mm (.045" to .049")</i>
<i>16.47 to 16.67 mm (.648" to .656")</i>	<i>1.35 to 1.45 mm (.053" to .057")</i>
<i>16.67 to 16.87 mm (.656" to .664")</i>	<i>1.55 to 1.65 mm (.061" to .065")</i>
<i>16.87 to 17.07 mm (.664" to .672")</i>	<i>1.75 to 1.85 mm (.068" to .073")</i>
<i>17.07 to 17.27 mm (.672" to .680")</i>	<i>1.95 to 2.05 mm (.076" to .081")</i>
<i>17.27 to 17.47 mm (.680" to .688")</i>	<i>2.15 to 2.25 mm (.084" to .089")</i>
<i>17.47 to 17.67 mm (.688" to .696")</i>	<i>2.35 to 2.45 mm (.093" to .096")</i>
<i>17.67 to 17.87 mm (.696" to .704")</i>	<i>2.55 to 2.65 mm (.100" to .104")</i>
<i>17.87 to 18.07 mm (.703" to .711")</i>	<i>2.75 to 2.85 mm (.108" to .112")</i>

Figure 208



Technical Service Information

TRANSMISSION ASSEMBLY (CONT'D) EXTERNAL COMPONENTS

3. Replace the caged needle bearings in extension housing as necessary using the proper pullers and drivers.
4. Install the output shaft to extension housing thrust bearing (28), by hand pressing into the bore, as shown in Figure 206.
5. The output shaft bearing thrust washer (27) is "Selective" and measurements are required to determine proper thickness to set rear end-play.
6. Place gaging bar across case extension housing gasket surface, as shown in Figure 207.
7. Measure from the gaging bar to the face of the output shaft, as shown in Figure 207.
Note: Record this as Dimension "B1".
8. Measure the thickness of the gaging bar as they vary in thickness (See Figure 207).
Note: Record this as Dimension "B2".
9. Subtract Dimension "B2" from "B1".
Note: Record this as Dimension "B".
10. Refer to the output shaft end-play chart shown in Figure 208 to determine proper "Selective" output shaft bearing thrust washer.
11. Install output shaft bearing thrust washer onto the output shaft, as shown in Figure 209.
12. Install a new extension housing gasket on the case surface, as shown in Figure 209.
13. Install the pre-assembled extension housing onto the case, as shown in Figure 209.
14. Install the seven extension housing bolts, as shown in Figure 209.
Note: Refer to bolt chart for identification of extension housing bolts.
15. Torque the seven extension housing bolts down to 22 Nm (16 ft.lb.).

Continued on Page 124

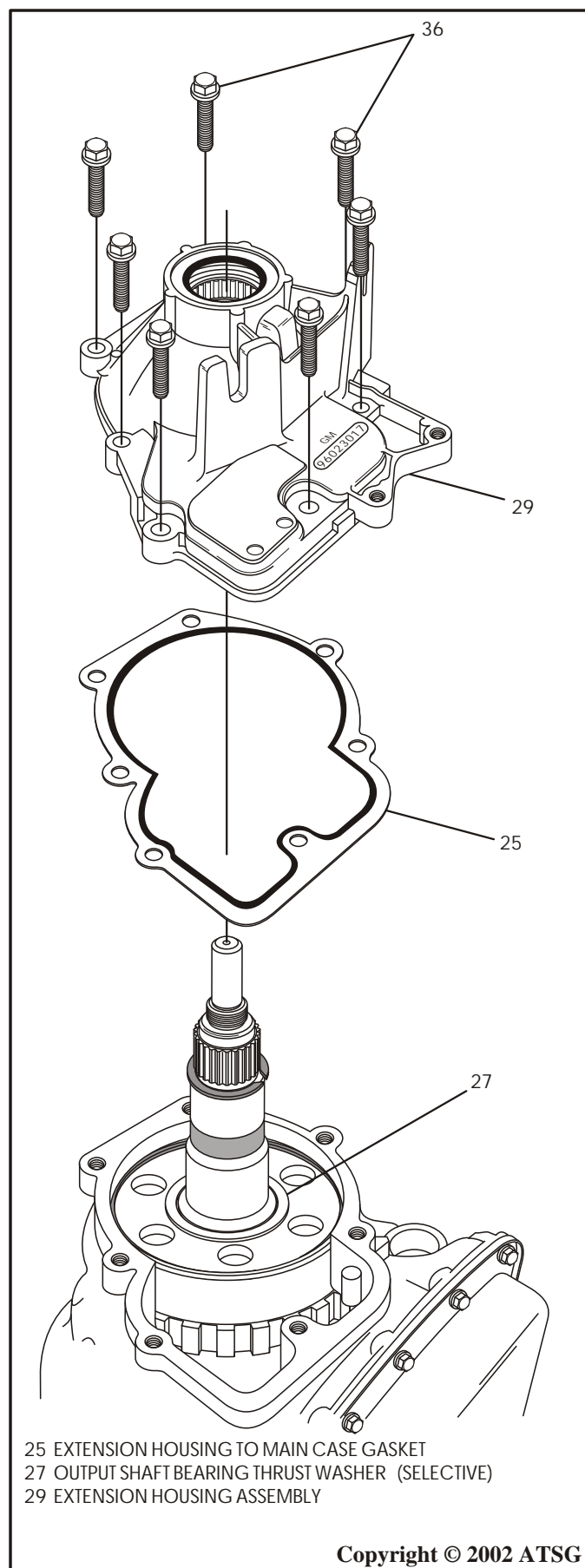

Figure 209



Technical Service Information

TRANSMISSION ASSEMBLY

EXTERNAL COMPONENTS (CONT'D)

16. Install a new "O" ring into the inside groove of the transmission yoke assembly, as shown in Figure 210, and lubricate with a small amount of Trans-Jel®.
17. Install the transmission yoke onto the output shaft, as shown in Figure 211.
18. Install the yoke washer and screw the nut onto output shaft, as shown in Figure 211.
19. Place the transmission in the Park position to engage the parking pawl.
20. Torque the drive shaft yoke flange nut down to 57 Nm (42 ft.lb.) (See Figure 211).
21. Rotate the transmission in fixture so that the bottom pan is facing down (See Figure 212).
22. Install a new turbine shaft "O" ring, as shown in Figure 212, if you have not already done so.
23. Lubricate turbine shaft "O" ring with a small amount of Trans-Jel®.

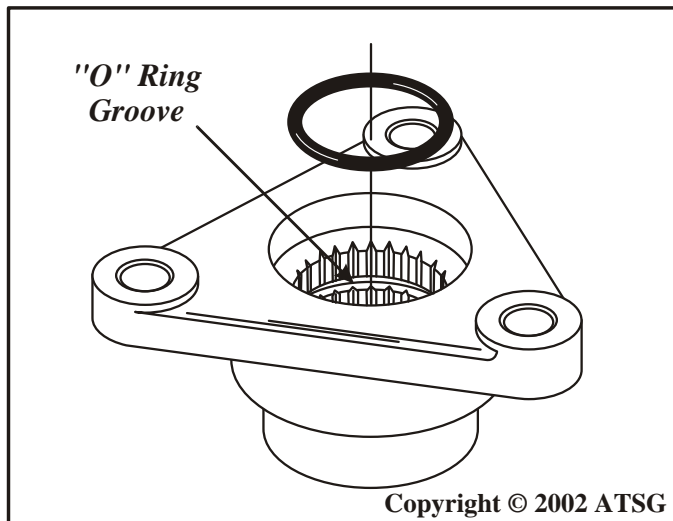

Figure 210

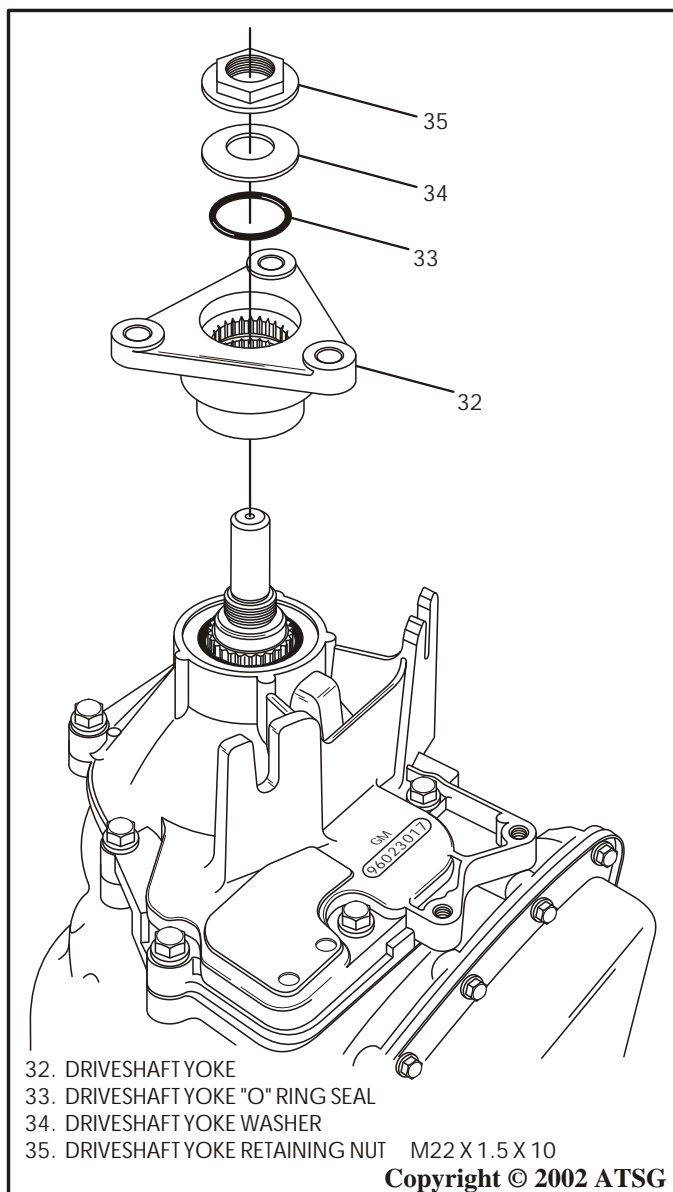

Figure 211

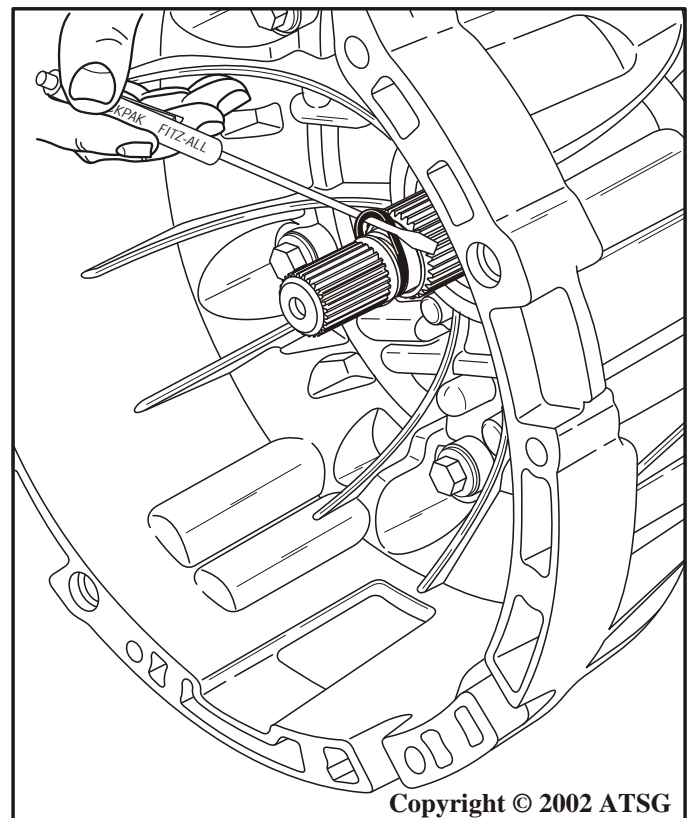

Figure 212

EXTERNAL COMPONENTS (CONT'D)

24. Install the torque converter carefully into the transmission, as shown in Figure 213. Ensure that it is fully seated and engaged with the oil pump gear.
25. Remove the transmission assembly from the work bench with a lifting device.
26. Remove the fixture from transmission. Refer to Figure 214.

CONGRATULATIONS,
YOU ARE FINISHED!

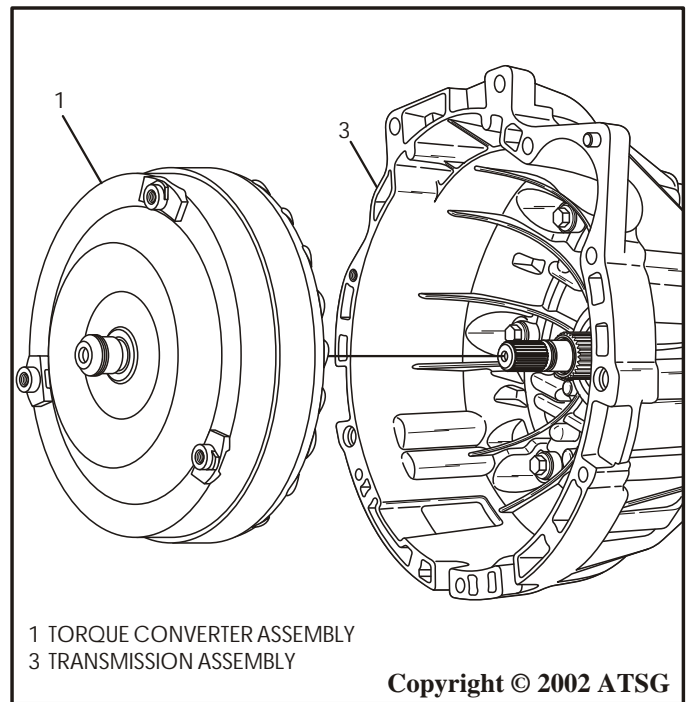

Figure 213

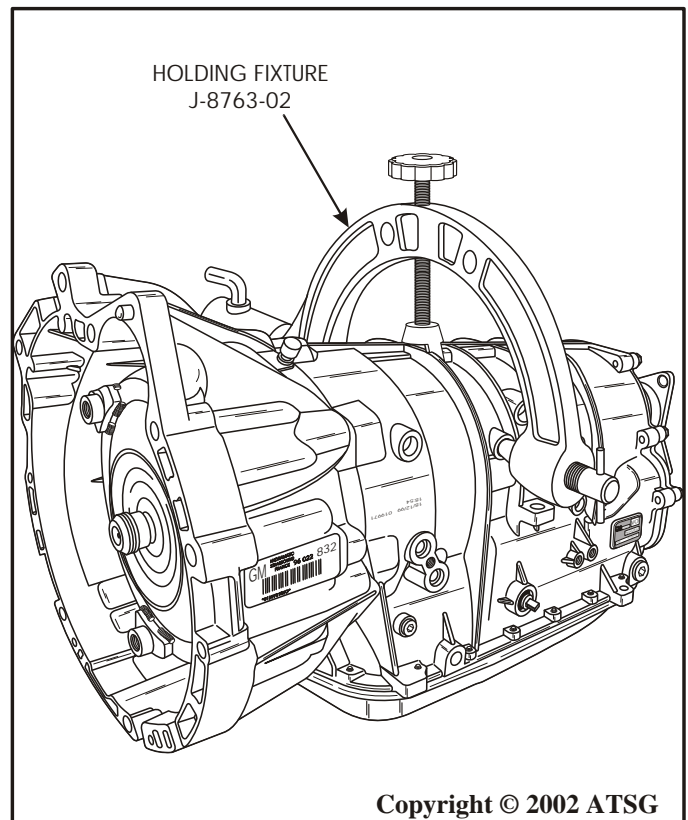
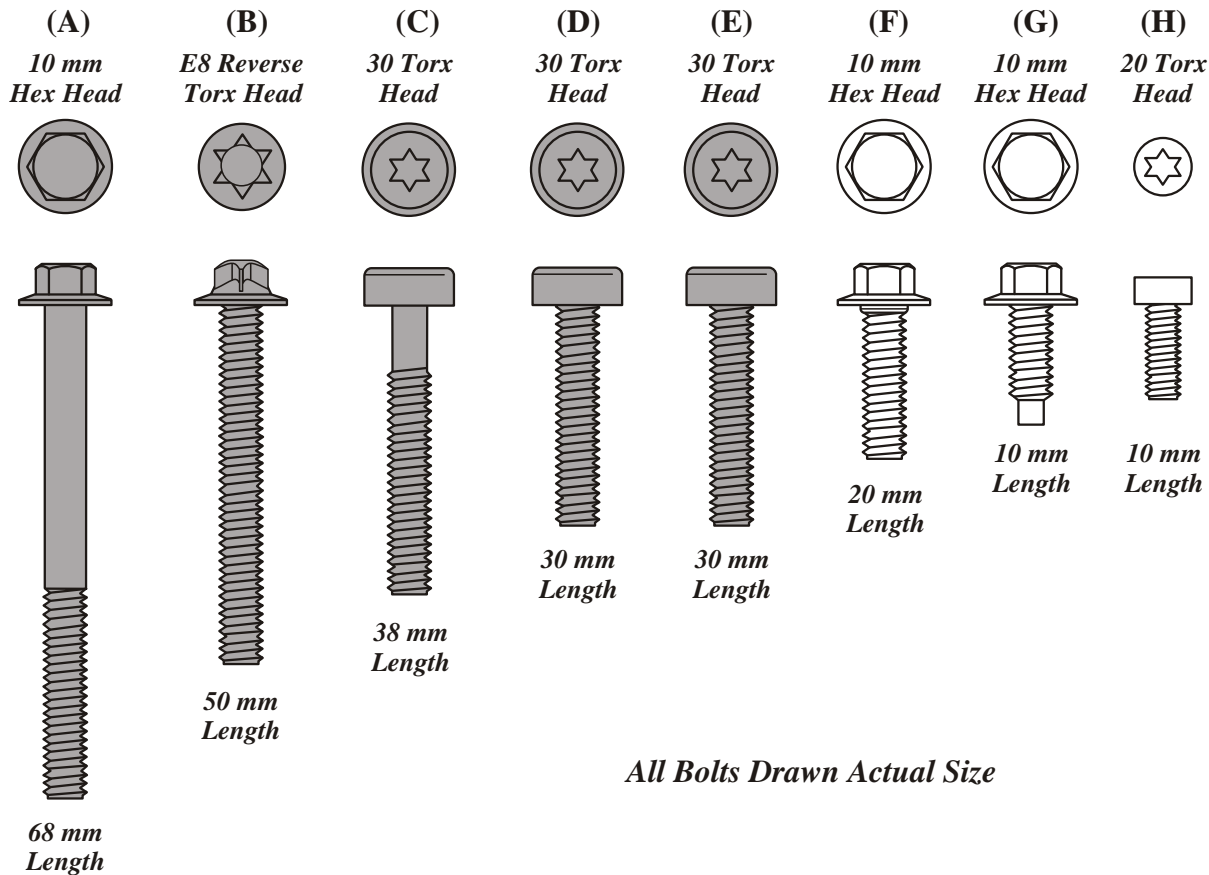

Figure 214



Technical Service Information

BOLT CHART



All Bolts Drawn Actual Size

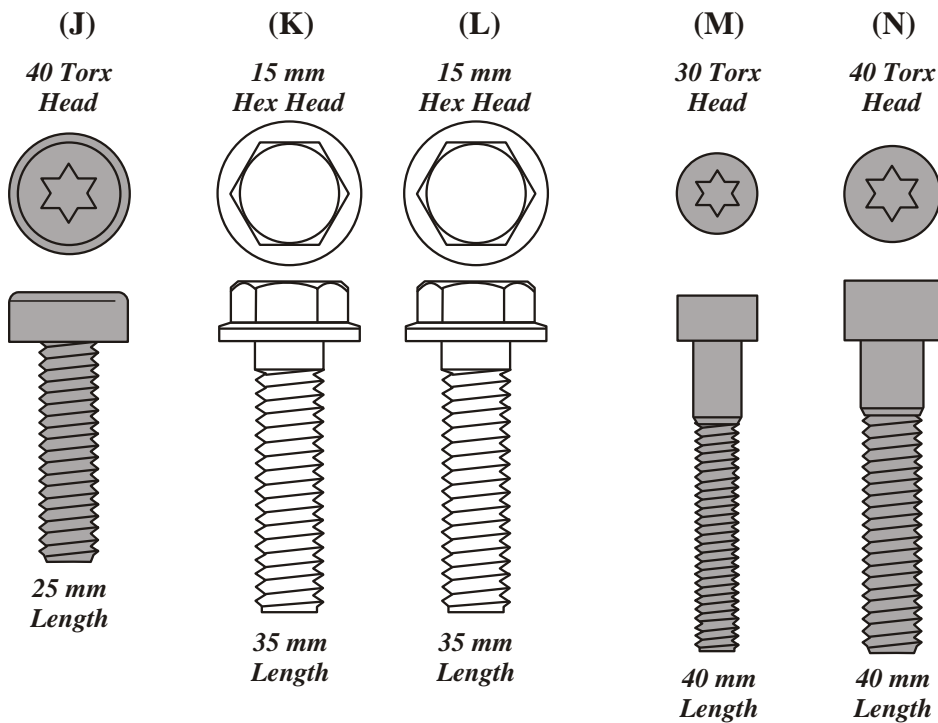

Copyright © 2002 ATSG

Figure 215



Technical Service Information

TORQUE SPECIFICATIONS					
DESCRIPTION	REF NO.	QTY	SIZE	METRIC	ENGLISH
<i>(K) Converter Housing To Main Case</i>	<i>2</i>	<i>7</i>	<i>M8 X 1.25 X 35</i>	<i>22 N·m</i>	<i>16 ft.lb.</i>
<i>(H) Converter Seal To Converter Housing</i>	<i>228</i>	<i>2</i>	<i>M4 X 0.7 X 10</i>	<i>3.6 N·m</i>	<i>31 in.lb.</i>
<i>(M) Pump Cover To Converter Housing</i>	<i>240</i>	<i>6</i>	<i>M6 X 1.00 X 40</i>	<i>11 N·m</i>	<i>8 ft.lb.</i>
<i>(N) Pump Cover To Converter Housing</i>	<i>241</i>	<i>5</i>	<i>M8 X 1.25 X 40</i>	<i>22 N·m</i>	<i>16 ft.lb.</i>
<i>Drain Plug To Bottom Pan</i>	<i>63</i>	<i>1</i>	<i>M14 X 1.5 X 10</i>	<i>20 N·m</i>	<i>15 ft.lb.</i>
<i>(G) Bottom Pan To Case</i>	<i>65</i>	<i>20</i>	<i>M6 X 1.00 X 16</i>	<i>11 N·m</i>	<i>8 ft.lb.</i>
<i>(L) Extension Housing To Main Case</i>	<i>35</i>	<i>7</i>	<i>M8 X 1.25 X 35</i>	<i>22 N·m</i>	<i>16 ft.lb.</i>
<i>(J) Parking Pawl Actuator Bracket</i>	<i>609</i>	<i>2</i>	<i>M8 X 1.25 X 25</i>	<i>22 N·m</i>	<i>16 ft.lb.</i>
<i>Drive Shaft Yoke To Output Shaft Nut</i>	<i>34</i>	<i>1</i>	<i>M22 X 1.5 X 10</i>	<i>57 N·m</i>	<i>42 ft.lb.</i>
<i>(F) Input Speed Sensor To Main Case</i>	<i>45</i>	<i>1</i>	<i>M6 X 1.00 X 20</i>	<i>11 N·m</i>	<i>8 ft.lb.</i>
<i>(E) Output Speed Sensor To Main Case</i>	<i>43</i>	<i>1</i>	<i>M6 X 1.00 X 30</i>	<i>11 N·m</i>	<i>8 ft.lb.</i>
<i>(D) Accumulator Housings To Valve Body</i>	<i>318</i>	<i>12</i>	<i>M6 X 1.00 X 30</i>	<i>11 N·m</i>	<i>8 ft.lb.</i>
<i>(C) Channel Plate To Valve Body</i>	<i>300</i>	<i>7</i>	<i>M6 X 1.00 X 38</i>	<i>11 N·m</i>	<i>8 ft.lb.</i>
<i>(C) Valve Body To Top Channel Plate</i>	<i>50</i>	<i>2</i>	<i>M6 X 1.00 X 38</i>	<i>11 N·m</i>	<i>8 ft.lb.</i>
<i>(B) Rear Valve Body To Main Case</i>	<i>49</i>	<i>4</i>	<i>M6 X 1.00 X 50</i>	<i>11 N·m</i>	<i>8 ft.lb.</i>
<i>(B) Front Valve Body To Main Case</i>	<i>51</i>	<i>4</i>	<i>M6 X 1.00 X 50</i>	<i>11 N·m</i>	<i>8 ft.lb.</i>
<i>(A) Valve Body Detent Spring To Main Case</i>	<i>53</i>	<i>1</i>	<i>M6 X 1.00 X 68</i>	<i>11 N·m</i>	<i>8 ft.lb.</i>
<i>(A) Valve Body Detent Spring To Channel Plate</i>	<i>53</i>	<i>1</i>	<i>M6 X 1.00 X 68</i>	<i>11 N·m</i>	<i>8 ft.lb.</i>
<i>Line Pressure Test Plug To Case</i>	<i>40</i>	<i>1</i>	<i>M10 X 1.00 X 8</i>	<i>11 N·m</i>	<i>8 ft.lb.</i>
<i>Fluid Level Fill/Check Plug To Case</i>	<i>36</i>	<i>1</i>	<i>M18 X 1.5 X 12</i>	<i>20 N·m</i>	<i>15 ft.lb.</i>

Reference Number refers to the callout number on the exploded views.

Copyright © 2002 ATSG

Figure 216



We wish to thank the following for supplying the actual transmission that have made these illustrations possible.

***INDEPENDENT TRANSMISSION SERVICE
AND MARIO ARISTIDES***

5846 SW 68TH STREET

SOUTH MIAMI, FLORIDA 33143

Phone (305) 666-3544

Phone (305) 666-4208

Fax (305) 666-8238