

BMW ZF-5HP-19FL PRELIMINARY INFORMATION

FOUND IN:

BMW 97-Current, 3 Series E46, 5 Series E39, 7 Series E38.

Audi 95-Current, A4, A8,

Audi 97-Current, A6,

Porsche Boxter 1996-1997

VW Passat 96-Current

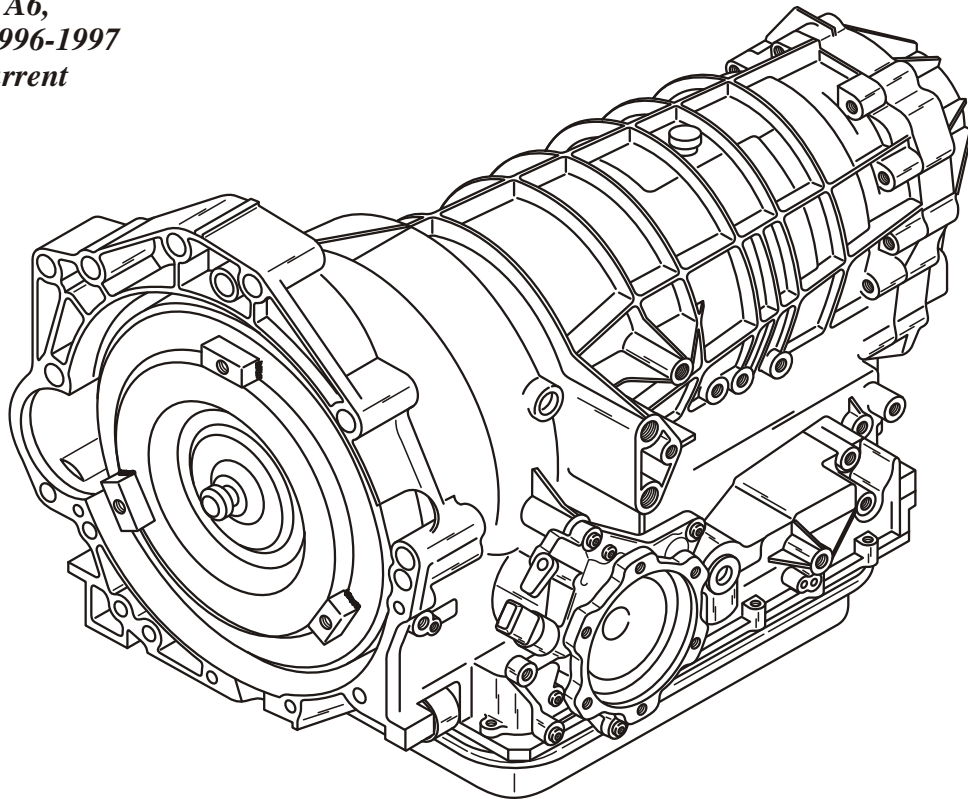

This transmission is manufactured in Germany by ZF and carries the designation ZF-5HP-19..

The ZF-5HP-19 Series is an electronically controlled, five speed automatic transmission with a lock-up clutch type torque converter. Two planetary gear sets, one Ravigneaux gear set and one standard planetary gear set on the output side, four rotating multiple disc clutches, three multiple disc brake clutches, and one sprag clutch (Freewheel) are used to provide the five forward speeds and reverse.

Copyright © 2000 ATSG

Figure 1

Refer to Figure 2 for Clutch and Band Application Chart.

Refer to Figure 3 and 4 for Manual Shift Lever Operation, and Failsafe Operation.

Refer to Figures 5, 6, and 7 for Solenoid identification and both MV Solenoid Operation and EDS Solenoid Operation and Tests.

Refer to Figure 8 for wiring harness identification, internal wiring schematic, and transmission case connector pin identification and functions.

Refer to Figure 9 for Shift Solenoid Application chart. Notice that EDS 1 Solenoid is used for line pressure control, and MV-4 is used for converter clutch.

Refer to Figure 10 for internal components resistance chart, with the pins identified for both the transmission case connector and the Electronic Control Unit.

Refer to Figure 11 for Upper Front Valve Body exploded view and identification of valves.

Refer to Figure 12 for Upper Rear Valve Body exploded view and identification of valves.

Refer to Figure 13 for Lower Front Valve Body exploded view and identification of valves.

Refer to Figure 14 for Lower Rear Valve Body exploded view and identification of valves.

Refer to Figure 15 for Channel Plate exploded view and turbine speed sensor location on the channel plate.

Refer to Figures 16, 17, and 18 for valve body retainer locations in the various valve bodies.

Refer to Figure 19 for the locations of the orifices, checkballs, screens, and the check valves and springs that are located in the channel plate.

ZF-5HP-19 CLUTCH AND BAND APPLICATION CHART

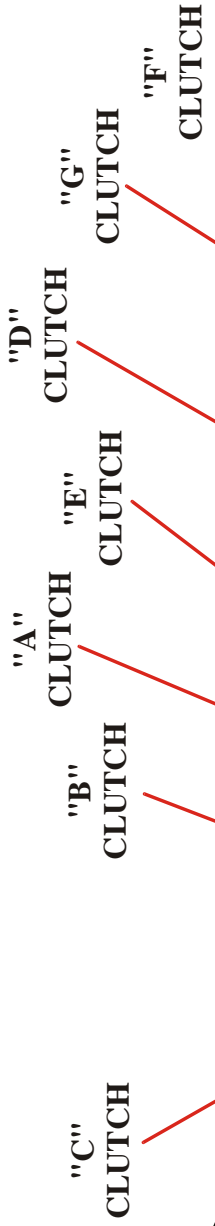

RANGE	"A" CLUT	"B" CLUT	"C" CLUT	"D" CLUT	"LOW" SPRAG	"E" CLUT	"F" CLUT	"G" CLUT	GEAR RATIO	CONV CLUT
Park								ON		
Reverse		ON		ON				ON	4.08	
Neutral								ON		
"D"-1st	ON				HOLD			ON	3.66	
"D"-2nd	ON		ON					ON	1.99	
"D"-3rd	ON		ON				ON		1.40	*
"D"-4th	ON					ON			1.00	*
"D"-5th			ON			ON	ON		0.74	*
"4"	Same as above, Automatic Shift 1st thru 4th, 5th gear is inhibited.									
"3"	Same as above, Automatic Shift 1st thru 3rd, 4th and 5th gear are inhibited.									
"2"	Same as above, Automatic Shift 1st thru 2nd, 3rd, 4th and 5th gear are inhibited.									

*Converter Clutch may be ON or OFF depending on vehicle speed and throttle position.

Figure 2

SHIFT QUADRANT

- Ⓟ = Parking Pawl Engaged
- Ⓡ = Reverse Gear
- Ⓝ = Neutral
- ⓓ = Automatic Shifts 1st thru 5th Gears
- ④ = Automatic Shifts 1st thru 4th Gears. 5th Gear is locked out.
- ③ = Automatic Shifts 1st thru 3rd Gears. 4th and 5th Gear is locked out.
- ② = Automatic Shifts 1st thru 2nd Gears. 3rd, 4th and 5th Gear is locked out.

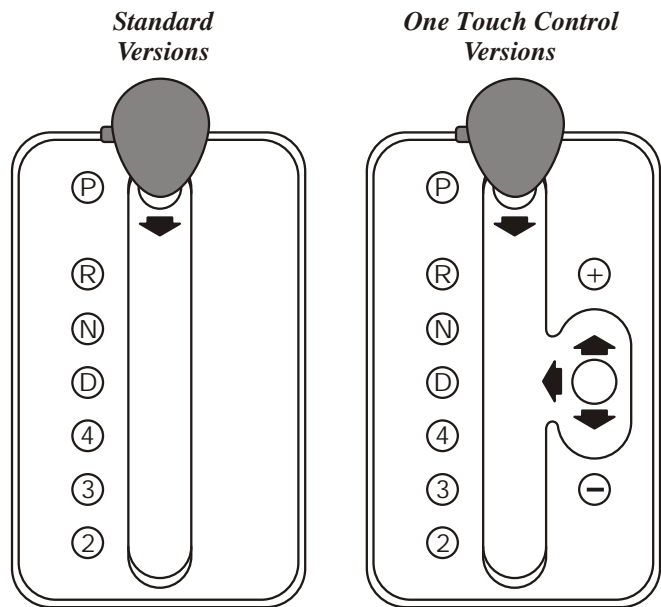

Note: 1st gear, which has an engine braking effect, is selected electronically, dependent on being in Manual Position 2 and at a suitable road speed.

ONE-TOUCH CONTROL VERSIONS

Standard versions have a shift quadrant using only the left gate as shown above. The versions that are equipped with One-Touch Control, supplied as an option and model dependent, have a two section shift quadrant, also shown above. Positions P, R, N, D, 4, 3, 2, can be selected in the left-hand gate and all shifts are automatic depending on which selection was made. When the selector lever is placed in the right-hand gate, the transmission can be up-shifted manually, by tapping the lever in the direction of the "Plus" symbol, or down-shifted manually by tapping the lever in the direction of the "Minus" symbol. The separate program switch is no longer needed, as functions A and B have replaced it.

"A" Left-Hand Gate = DSP (Dynamic Shift Program)

With the selector lever in the left-hand gate, the Dynamic Shift Program (DSP) looks at the speed of accelerator pedal movement, engine speed, vehicle acceleration via output speed and other important parameters in the control unit.

The Electronic Control Unit (ECU) includes modules which will automatically modify the transmissions shift characteristics according to the driving style and the road conditions. These modules effectively replace the program switch.

If the engine temperature is below approximately 40°C (104°F) when it is started, the ECU control system enters a special warm-up program in order to shorten the catalytic converter's warming-up phase. This warm-up program is terminated after approximately 2 minutes of operation.

Continued on next Page

Copyright © 2000 ATSG

Figure 3

"A" Left-Hand Gate = DSP (Dynamic Shift Program) (Cont'd)

If the speed of the accelerator pedal movement is greatly varied, the shift points are modified for maximum fuel economy, or a more sporting driving style accordingly. There are three shift patterns for this purpose.

- 1. = Comfort Oriented, Economical Driving Style**
- 2. = Average Driving Style**
- 3. = Sports Oriented, High Performance Driving Style**

When the vehicle is started cold, it moves off in shift pattern number one, provided that the transmission temperature is above 40°C (104°F). This shift pattern places the emphasis on maximum fuel economy. If a more enthusiastic driving style is required, detected by the accelerator opening and closing more rapidly, the ECU switches between the shift patterns and adopting shift pattern three where necessary.

If a calmer driving style is resumed, the ECU returns to the lower shift pattern, and will once again place the emphasis on fuel consumption.

"B" Right-Hand Gate = Manual Shift Program

When the selector lever is moved to the right-hand gate, the current gear is retained, and the transmission can be shifted to a lower or higher gear using the one-touch function.

There are engine speed limits for each gear, as in the transmission can only be shifted down if the maximum engine speed will not be exceeded by doing so. No mandatory upshifts will take place.

If the One-Touch feature is not used when the selector lever is in the right-hand gate, for durability concerns, the transmission is allowed to down-shift automatically to 1st gear.

FAILSAFE OPERATION

When a system fault is detected which could impair normal reliable operation, the ECU module interrupts the power supply to Pin 12 at the transmission case connector. The ECU module also alerts the driver of any faults by signaling the vehicles "check control" system. To enable the vehicle to be driven to a repair shop, the following manual gear selections are permitted:

<i>Selector Lever Position</i>	P R N D 4 3 2
<i>Actual Gear Obtained</i>	P R N 4 4 4 4

ZF-5HP-19 SOLENOID IDENTIFICATION AND LOCATIONS

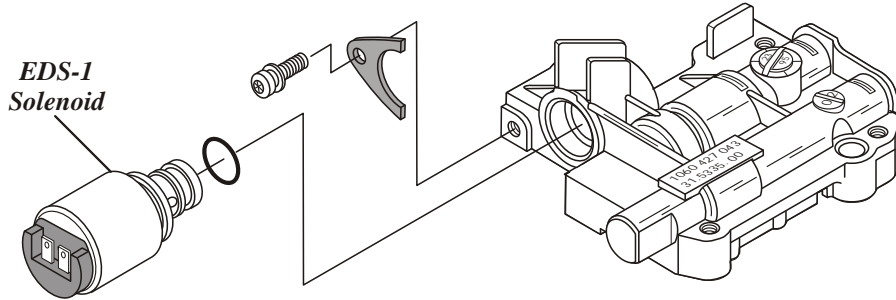

SPECIAL NOTE:

*EDS-1 Solenoid
.650" Snout Diameter
Requires Green "O" Ring*

*EDS-2, 3, 4 Solenoids
.670" Snout Diameter
Requires Black "O" Ring*

*MV-1, 2, 3 Solenoids
Use NO "O" Rings*

<i>ZF Part Numbers</i>	
<i>EDS-1 Solenoid</i>	<i>0501 209 875</i>
<i>EDS-2, 3, 4, Solenoid</i>	<i>0501 208 562</i>
<i>MV-1, 2, 3, Solenoid</i>	<i>0501 313 506</i>

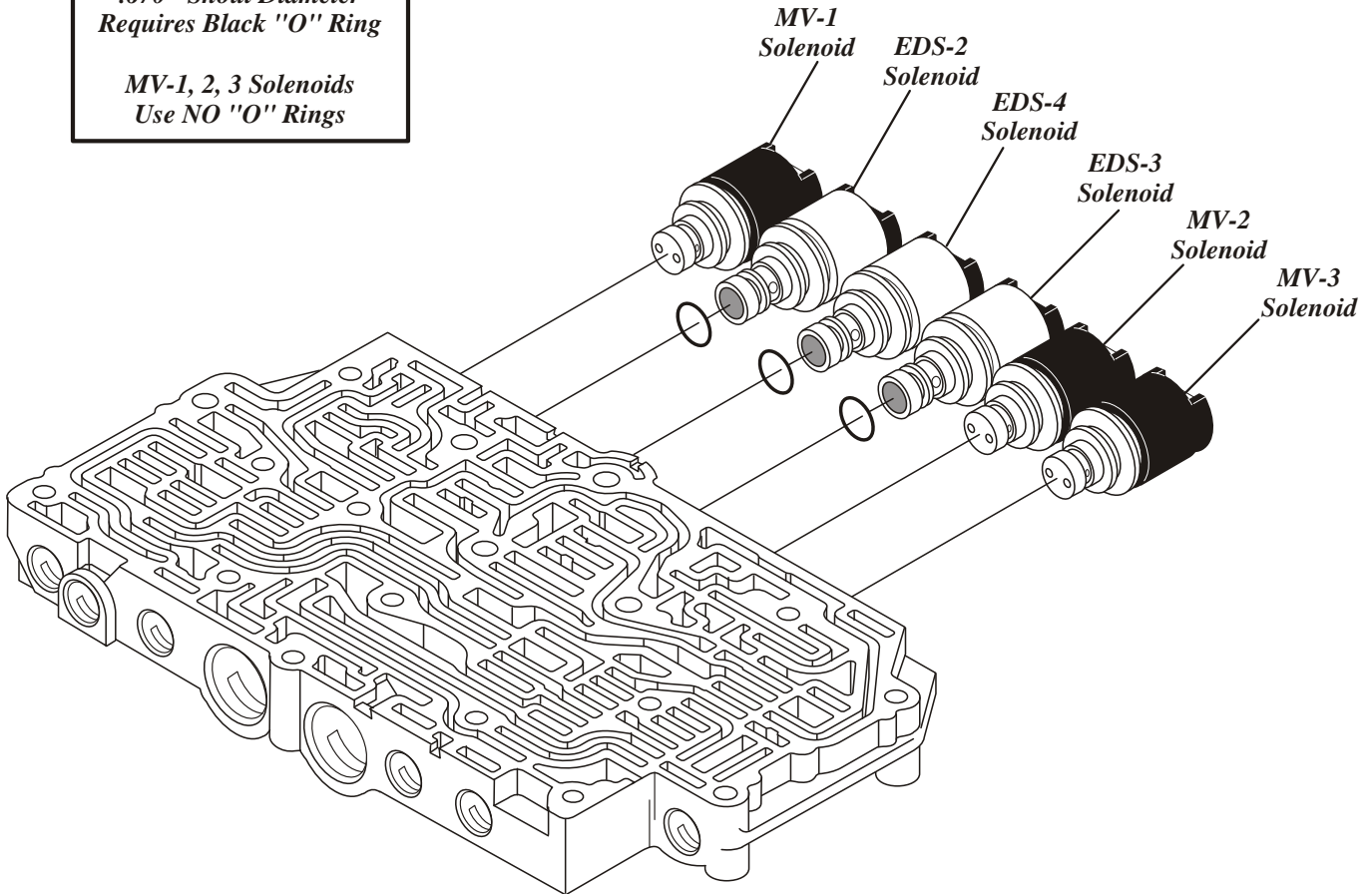

Copyright © 2000 ATSG

Figure 5

MV1, 2 AND 3 OPERATION

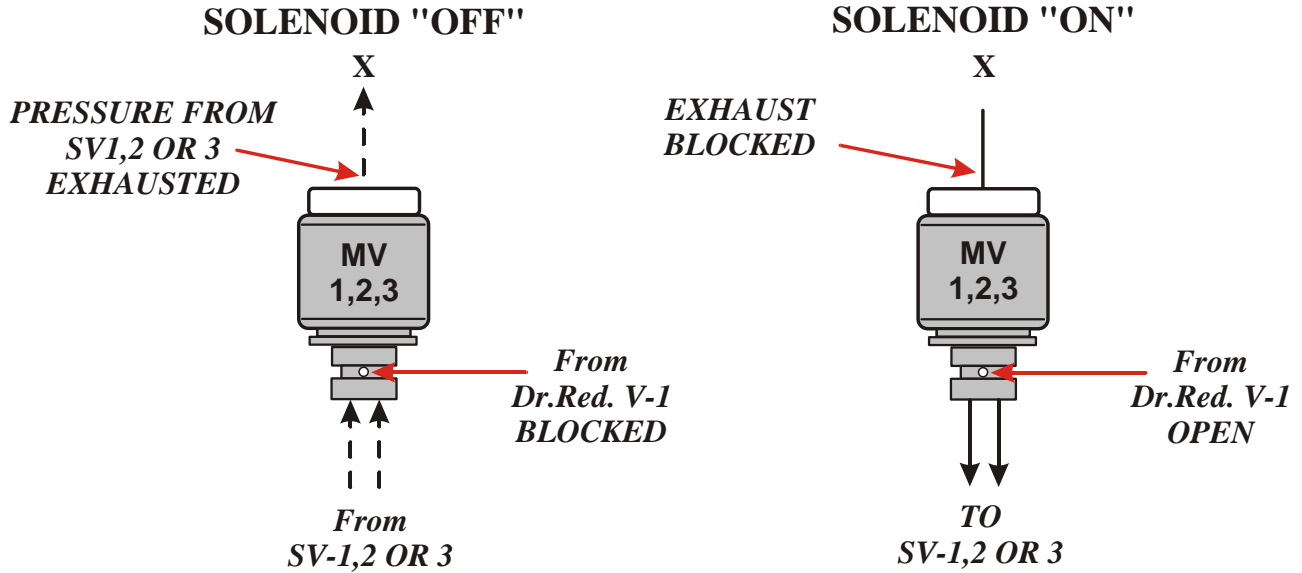

SUMMARY:

When MV 1, 2 or 3 is "OFF" Solenoid reducing pressure, from Dr.Red. V-1, is blocked by the solenoid and oil pressure from SV 1, 2 or 3 is exhausted at the rear of the solenoid.

When MV 1, 2 or 3 is "ON" Solenoid reducing pressure, From Dr.Red. V-1, is open through the solenoid and is applied to SV 1, 2 or 3. The exhaust at the rear of the solenoid

EDS 2, 3 AND 4 OPERATION

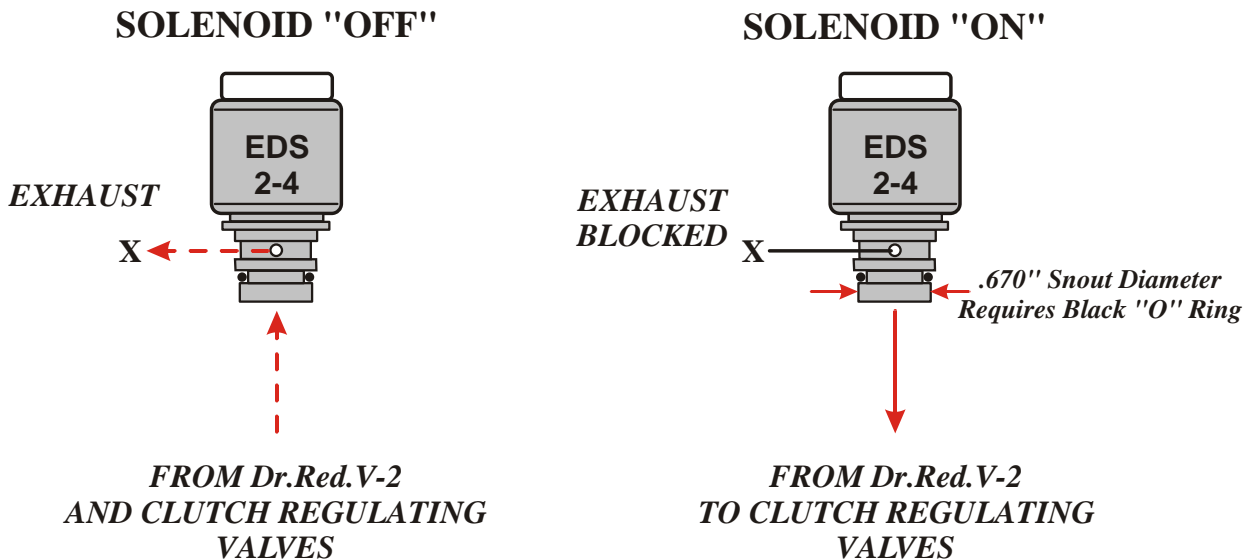

SUMMARY:

When EDS 2-5 solenoids are "OFF" they exhaust orificed solenoid reducing pressure, from Dr. Red. V-2, and the oil pressure from the clutch regulating valves releasing them.

When EDS 2-5 solenoids are "ON" the exhaust is blocked by the solenoid and solenoid reducing pressure, from Dr. Red. V-2, is applied to operate clutch regulating valves.

Copyright © 2000 ATSG

Figure 6

EDS-1 OPERATION (Line Pressure Solenoid)

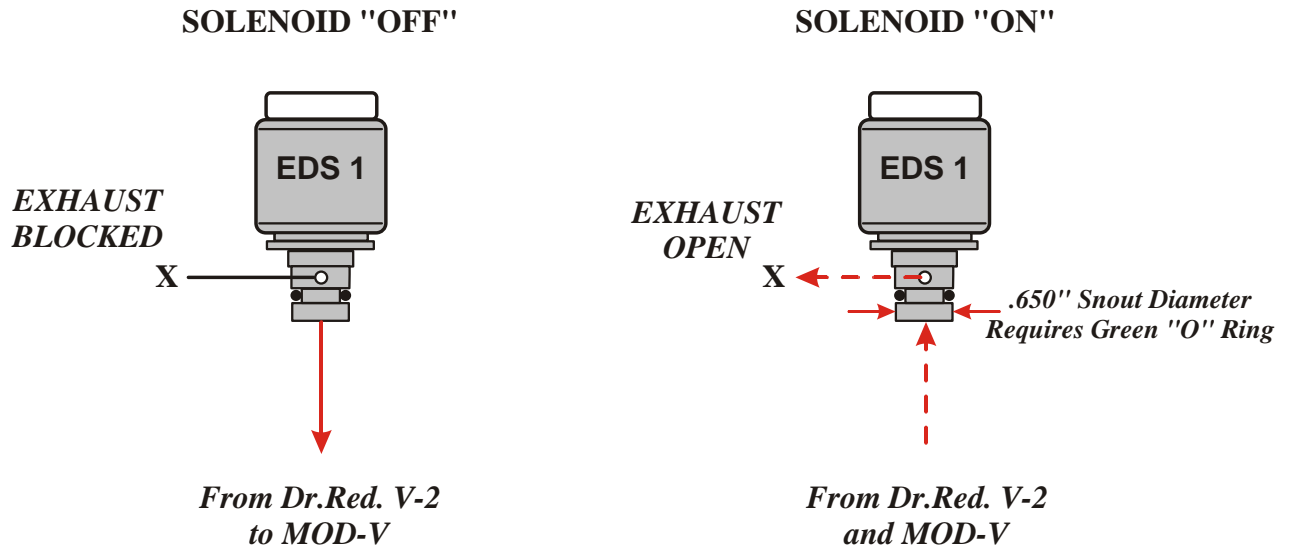

SUMMARY:

When EDS 1 solenoid is "OFF," solenoid reducing pressure, from Dr. Red. V-2, is high to MOD-V valve which creates high line pressure.

When EDS 1 solenoid is "ON," solenoid reducing pressure, from Dr. Red. V-2, is low to

Copyright © 2000 ATSG

Figure 7

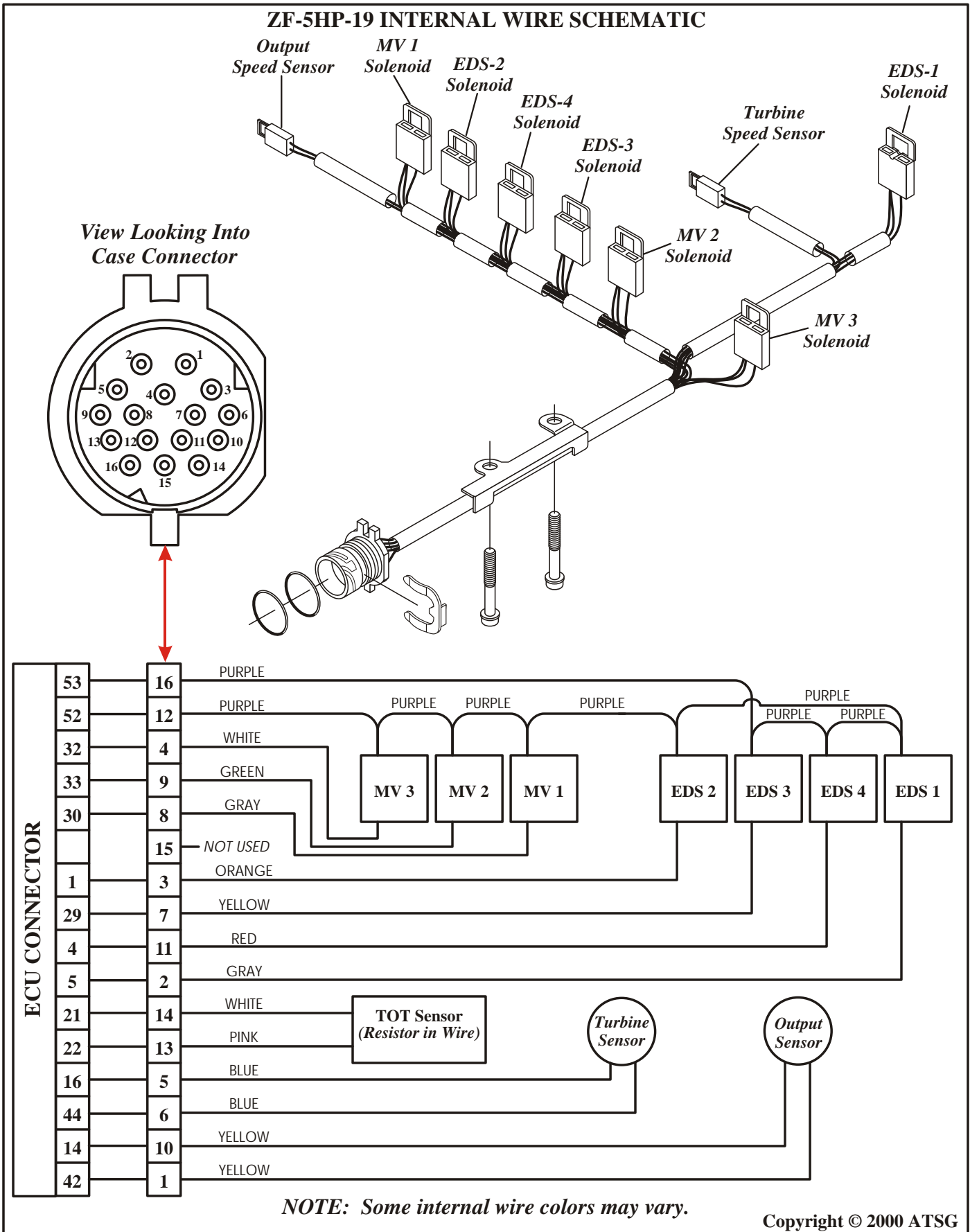

Figure 8

ZF-5HP-19 SOLENOID APPLICATION CHART

<i>Selector Lever Position</i>	<i>MV 1 Solenoid</i>	<i>MV 2 Solenoid</i>	<i>MV 3 Solenoid</i>	<i>EDS 1 Solenoid</i>	<i>EDS 2 Solenoid</i>	<i>EDS 3 Solenoid</i>	<i>EDS 4 Solenoid</i>	GEAR RATIO
PARK	ON			**				
REVERSE	ON		⊗	**		*		4.08:1
NEUTRAL	ON	ON		**		*		
D-1ST	ON	ON		**		*		3.66:1
D-2ND	ON	ON		**	*	*		1.99:1
D-3RD		ON		**	*		-*-	1.40:1
D-4TH				**			-*-	1.00:1
D-5TH			-*	**	*		-*-	0.74:1
Failsafe (4th)	OFF	OFF	OFF	OFF	OFF	OFF	OFF	1.00:1

SOLENOID CHART LEGEND

<i>Symbol</i>	<i>Description</i>
ON	MV 1, MV 2 and MV 3 Solenoids are energized by the Electronic Transmission Control unit and have two functions. They are Open or Closed. Energized (On), there is pressure in circuit.
⊗	MV 3 is turned "ON" if reverse is selected at a high vehicle speed, to inhibit reverse engagement.
**	EDS 1 is used for line pressure control only, and operates from 0 to 0.8 amps. When the solenoid is "OFF" (0 amps), pressure is high. EDS 1 pressure is "Lowered" as the solenoid is modulated by the control unit.
*	EDS 2, EDS 3, and EDS 4 Solenoids are also pulse modulated but are exactly the opposite of EDS 1 Solenoid. When these solenoids are "ON" oil pressure in the hydraulic circuit is high, and when they are "OFF" pressure in the hydraulic circuit is low.
-*	Solenoid "OFF" (hydraulic pressure low), then Solenoid "ON" (hydraulic pressure high).
*-	Solenoid "ON" briefly (hydraulic pressure high), then Solenoid "OFF" (hydraulic pressure low). The pressure acts briefly on regulator valves to cushion clutch application.
-*-	EDS 4 Solenoid is used for Torque Converter Clutch apply and release only, and depends on throttle position and vehicle speed as to its application.

Figure 9

SOLENOID AND SENSOR RESISTANCE CHART

Solenoid	Case Connector	Control Unit Connector	Resistance In Ohms
	Pin Numbers - +	Pin Numbers - +	
MV 1	8 and 12	30 and 52	30 - 34 Ω
MV 2	9 and 12	33 and 52	30 - 34 Ω
MV 3	4 and 12	32 and 52	30 - 34 Ω
EDS 1	2 and 12	5 and 52	5.2 - 6.8 Ω
EDS 2	3 and 12	1 and 52	6.2 - 7.8 Ω
EDS 3	7 and 12	29 and 52	6.2 - 7.8 Ω
EDS 4	11 and 12	4 and 52	6.2 - 7.8 Ω
TOT	13 and 14	21 and 22	1000 Ω at 25° C
OSS	1 and 10	14 and 42	292 - 358 Ω
TSS	5 and 6	44 and 16	292 - 358 Ω

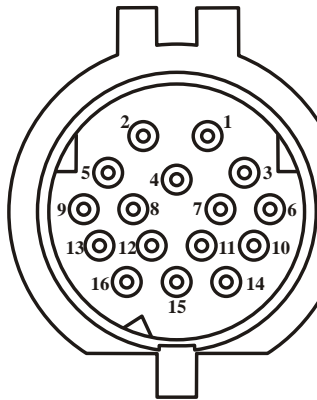

View Looking Into
Case Connector

Electronic Control Unit Connector Pin Identification

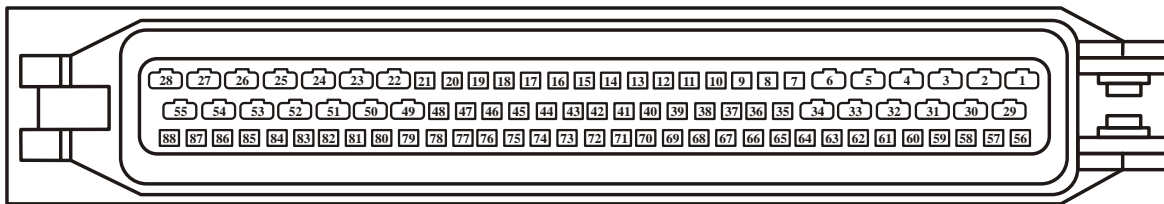

Copyright © 2000 ATSG

Figure 10

**ZF-5HP-19FL
UPPER FRONT VALVE BODY**

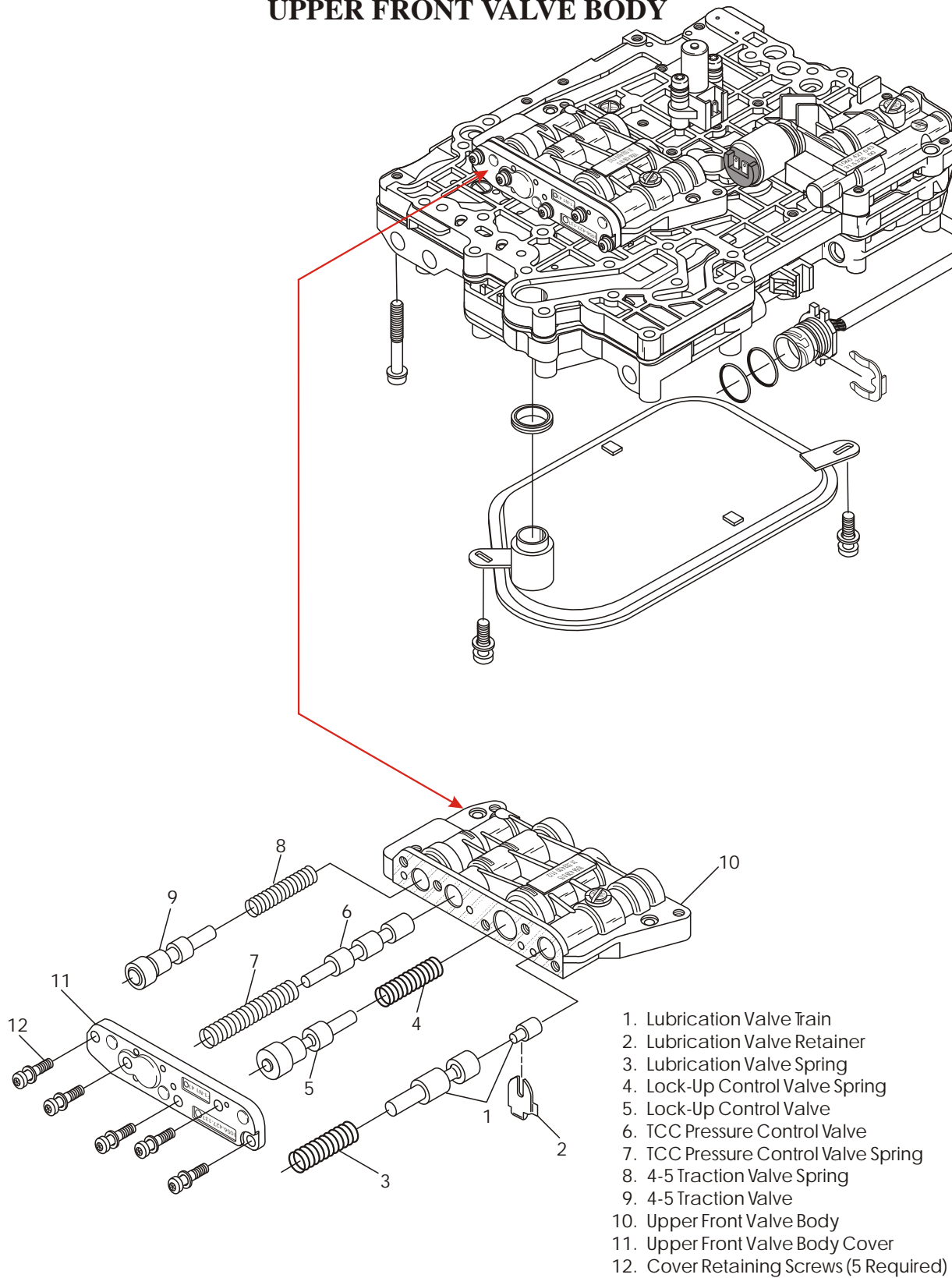

- 1. Lubrication Valve Train
- 2. Lubrication Valve Retainer
- 3. Lubrication Valve Spring
- 4. Lock-Up Control Valve Spring
- 5. Lock-Up Control Valve
- 6. TCC Pressure Control Valve
- 7. TCC Pressure Control Valve Spring
- 8. 4-5 Traction Valve Spring
- 9. 4-5 Traction Valve
- 10. Upper Front Valve Body
- 11. Upper Front Valve Body Cover
- 12. Cover Retaining Screws (5 Required)

Copyright © 2000 ATSG

Figure 11

ZF-5HP-19FL UPPER REAR VALVE BODY

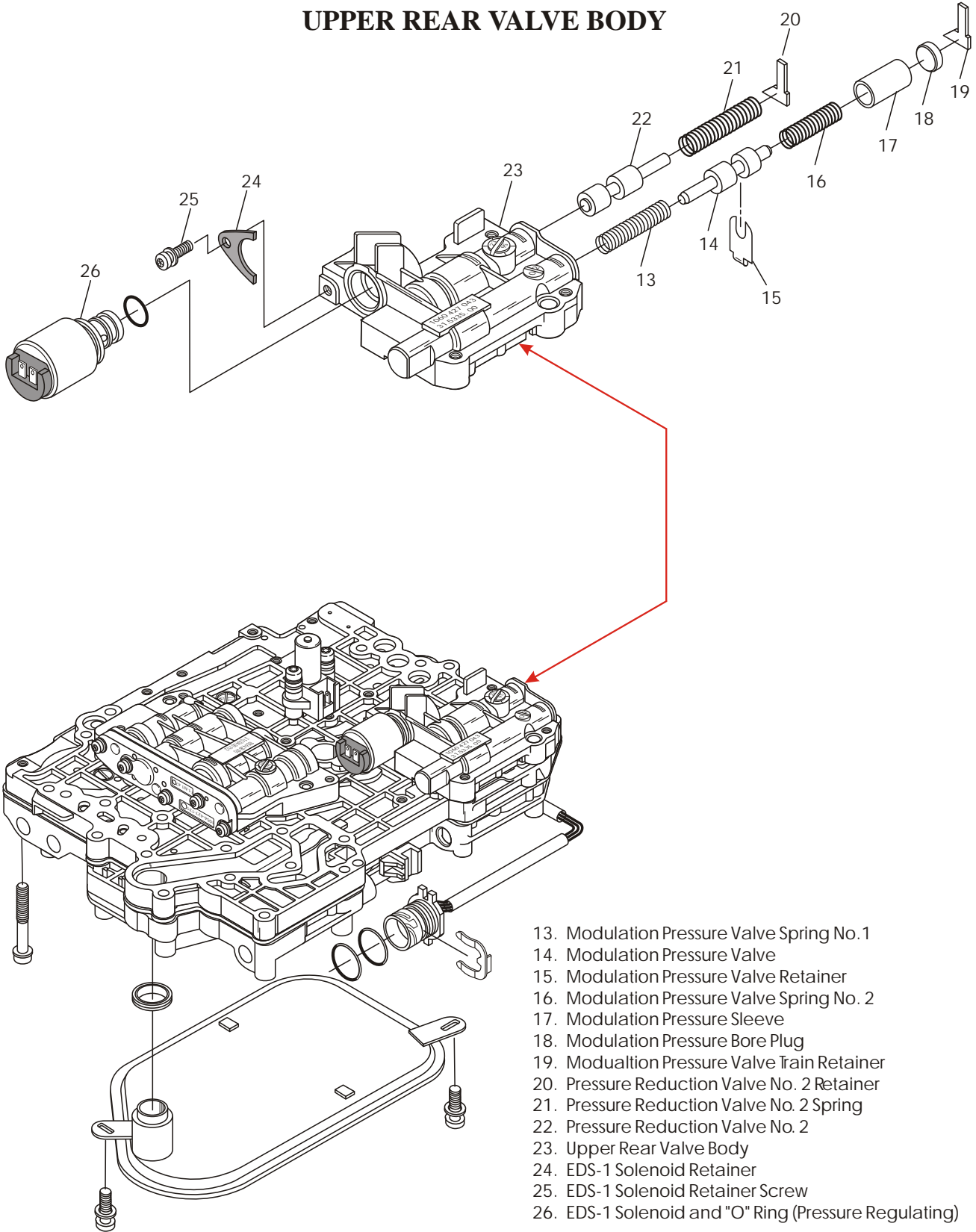

Copyright © 2000 ATSG

Figure 12

ZF-5HP-19FL LOWER FRONT VALVE BODY

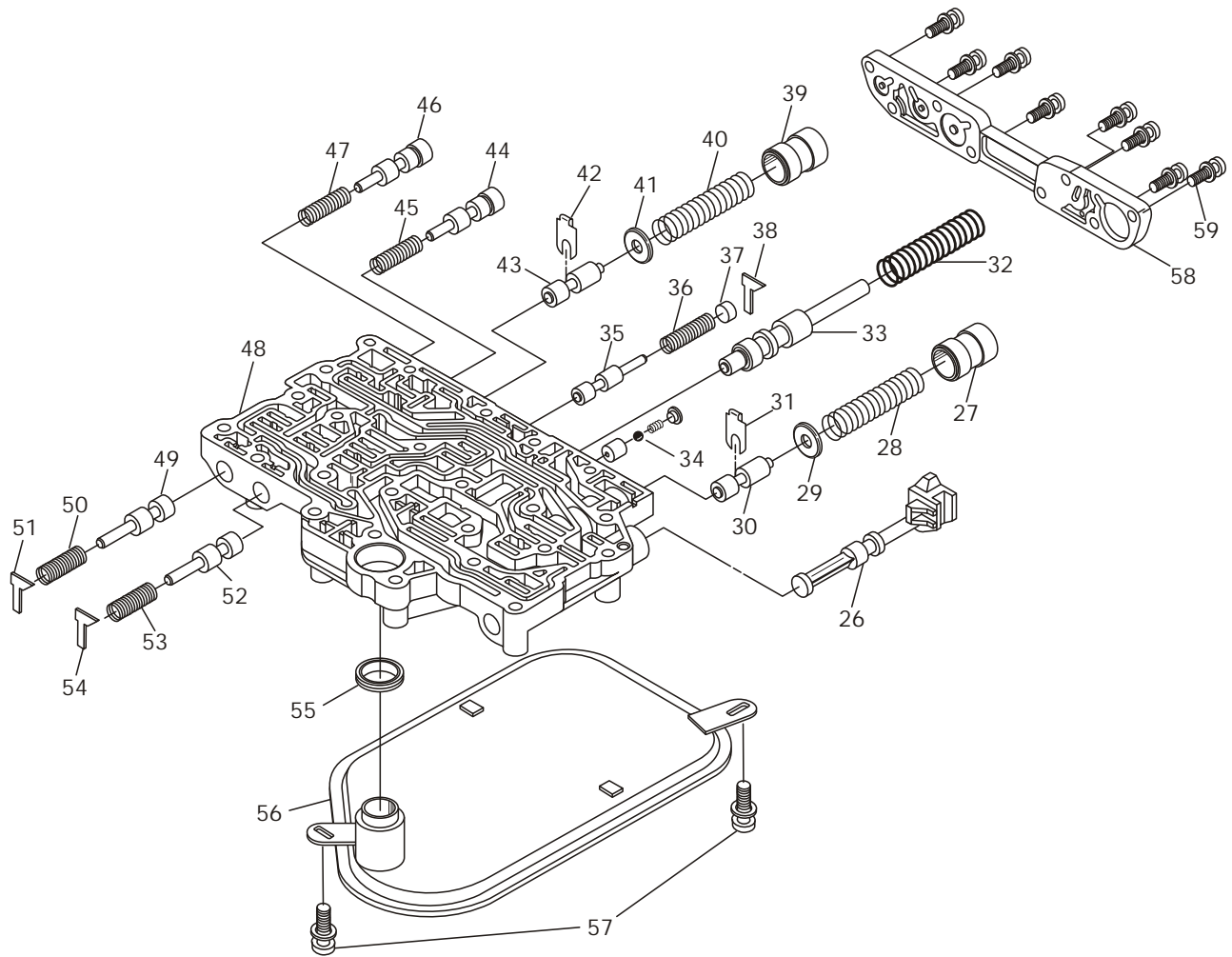

- | | |
|---|---|
| 26. Manual Shift Valve (W-S) | 43. "A" Clutch Accumulator Regulator Valve |
| 27. "E" Clutch Damper Valve | 44. "G" Clutch Accumulator Regulator Valve |
| 28. "E" Clutch Damper Valve Spring | 45. "G" Clutch Accumulator Regulator Valve Spring |
| 29. "E" Clutch Damper Valve Spring Seat | 46. "C" Clutch Accumulator Regulator Valve |
| 30. "E" Clutch Accumulator Regulator Valve | 47. "C" Clutch Accumulator Regulator Valve Spring |
| 31. "E" Clutch Accumulator Regulator Valve Retainer | 48. Lower Front Valve Body |
| 32. Main Pressure Regulator Valve Spring | 49. "C" Clutch Shift Valve |
| 33. Main Pressure Regulator Valve | 50. "C" Clutch Shift Valve Spring |
| 34. "D" Clutch One-Way Check Valve Assembly | 51. "C" Clutch Shift Valve Retainer |
| 35. 5-4 Traction Valve | 52. "G" Clutch Shift Valve |
| 36. 5-4 Traction Valve Spring | 53. "G" Clutch Shift Valve Spring |
| 37. 5-4 Traction Valve Bore Plug | 54. "G" Clutch Shift Valve Retainer |
| 38. 5-4 Traction Valve Train Retainer | 55. Filter Seal |
| 39. "A" Clutch Damper Valve | 56. Oil Filter |
| 40. "A" Clutch Damper Valve Spring | 57. Oil Filter Retaining Screws |
| 41. "A" Clutch Damper Valve Spring Seat | 58. Lower Valve Body Cover |
| 42. "A" Clutch Accumulator Regulator Valve Retainer | 59. Lower Valve Body Cover Screws (8 Required) |

Copyright © 2000 ATSG

Figure 13

ZF-5HP-19FL LOWER REAR VALVE BODY

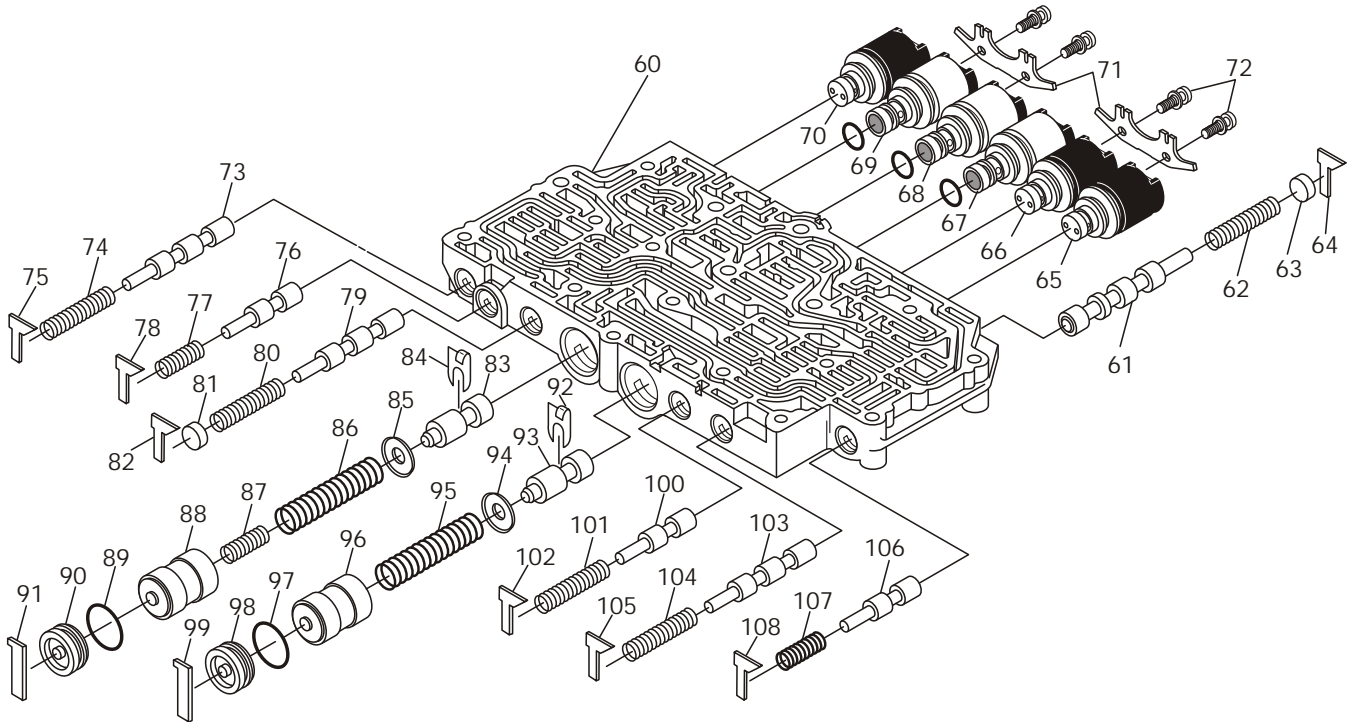

- | | |
|---|---|
| 60. Lower Rear Valve Body | 85. "D" Clutch Damper Valve Spring Seat |
| 61. Number 1 Shift Valve | 86. "D" Clutch Damper Valve Outer Spring |
| 62. Number 1 Shift Valve Spring | 87. "D" Clutch Damper Valve Inner Spring |
| 63. Number 1 Shift Valve Bore Plug | 88. "D" Clutch Damper Valve |
| 64. Number 1 Shift Valve Retainer | 89. "D" Clutch Valve Train Bore Plug "O" Ring |
| 65. MV-3 Solenoid (On-Off) | 90. "D" Clutch Valve Train Bore Plug |
| 66. MV-2 Solenoid (On-Off) | 91. "D" Clutch Valve Train Bore Plug Retainer |
| 67. EDS-3 Solenoid and "O" Ring (Pressure Regulating) | 92. "F" Clutch Accumulator Regulator Valve Retainer |
| 68. EDS-4 Solenoid and "O" Ring (Pressure Regulating) | 93. "F" Clutch Accumulator Regulator Valve |
| 69. EDS-2 Solenoid and "O" Ring (Pressure Regulating) | 94. "F" Clutch Damper Valve Spring Seat |
| 70. MV-1 Solenoid (On-Off) | 95. "F" Clutch Damper Valve Spring |
| 71. Solenoid Retaining Brackets (2 Required) | 96. "F" Clutch Damper Valve |
| 72. Solenoid Retaining Bracket Screws (4 Required) | 97. "F" Clutch Valve Train Bore Plug "O" Ring |
| 73. Traction Coast Valve | 98. "F" Clutch Valve Train Bore Plug |
| 74. Traction Coast Valve Spring | 99. "F" Clutch Valve Train Bore Plug Retainer |
| 75. Traction Coast Valve Train Retainer | 100. Reverse Gear Valve |
| 76. TCC Release Regulator Valve | 101. Reverse Gear Valve Spring |
| 77. TCC Release Regulator Valve Spring | 102. Reverse Gear Valve Train Retainer |
| 78. TCC Release Regulator Valve Train Retainer | 103. Number 2 Shift Valve |
| 79. Number 3 Shift Valve | 104. Number 2 Shift Valve Spring |
| 80. Number 3 Shift Valve Spring | 105. Number 2 Shift Valve Train Retainer |
| 81. Number 3 Shift Valve Train Bore Plug | 106. Pressure Reduction Valve |
| 82. Number 3 Shift Valve Train Retainer | 107. Pressure Reduction Valve Spring |
| 83. "D" Clutch Accumulator Regulator Valve | 108. Pressure Reduction Valve Train Retainer |
| 84. "D" Clutch Accumulator Regulator Valve Retainer | |

Copyright © 2000 ATSG

Figure 14

**ZF-5HP-19FL
TRANSFER PLATE, SPACER PLATE, AND
TURBINE SPEED SENSOR**

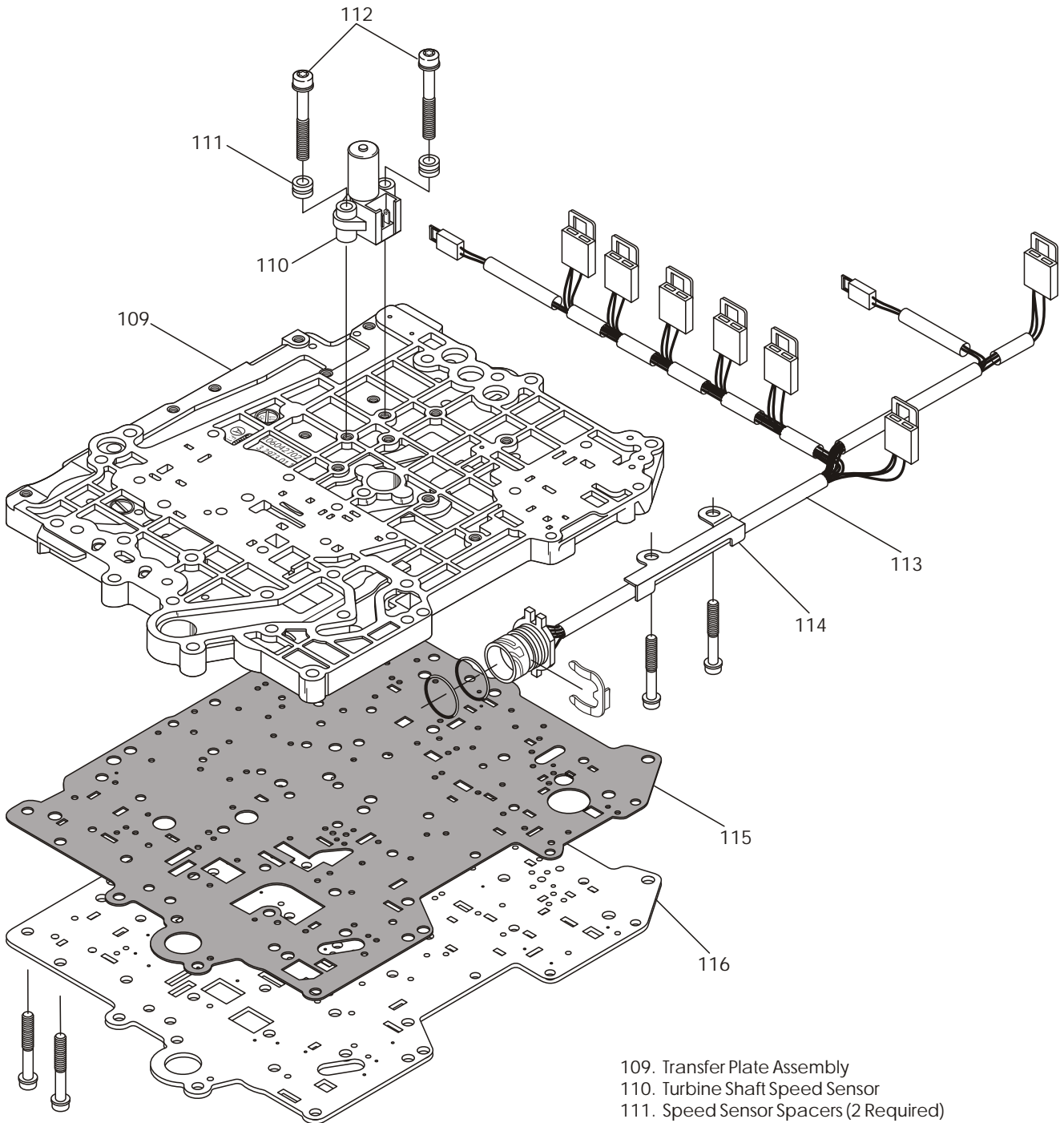

- 109. Transfer Plate Assembly
- 110. Turbine Shaft Speed Sensor
- 111. Speed Sensor Spacers (2 Required)
- 112. Speed Sensor Retaining Bolts (2 Required)
- 113. Internal Wiring Harness Assembly
- 114. Internal Wire Harness Retaining Bracket
- 115. Spacer Plate To Transfer Plate Gasket
- 116. Valve Body Spacer Plate

Copyright © 2000 ATSG

Figure 15

ZF-5HP-19FL LOWER FRONT VALVE BODY

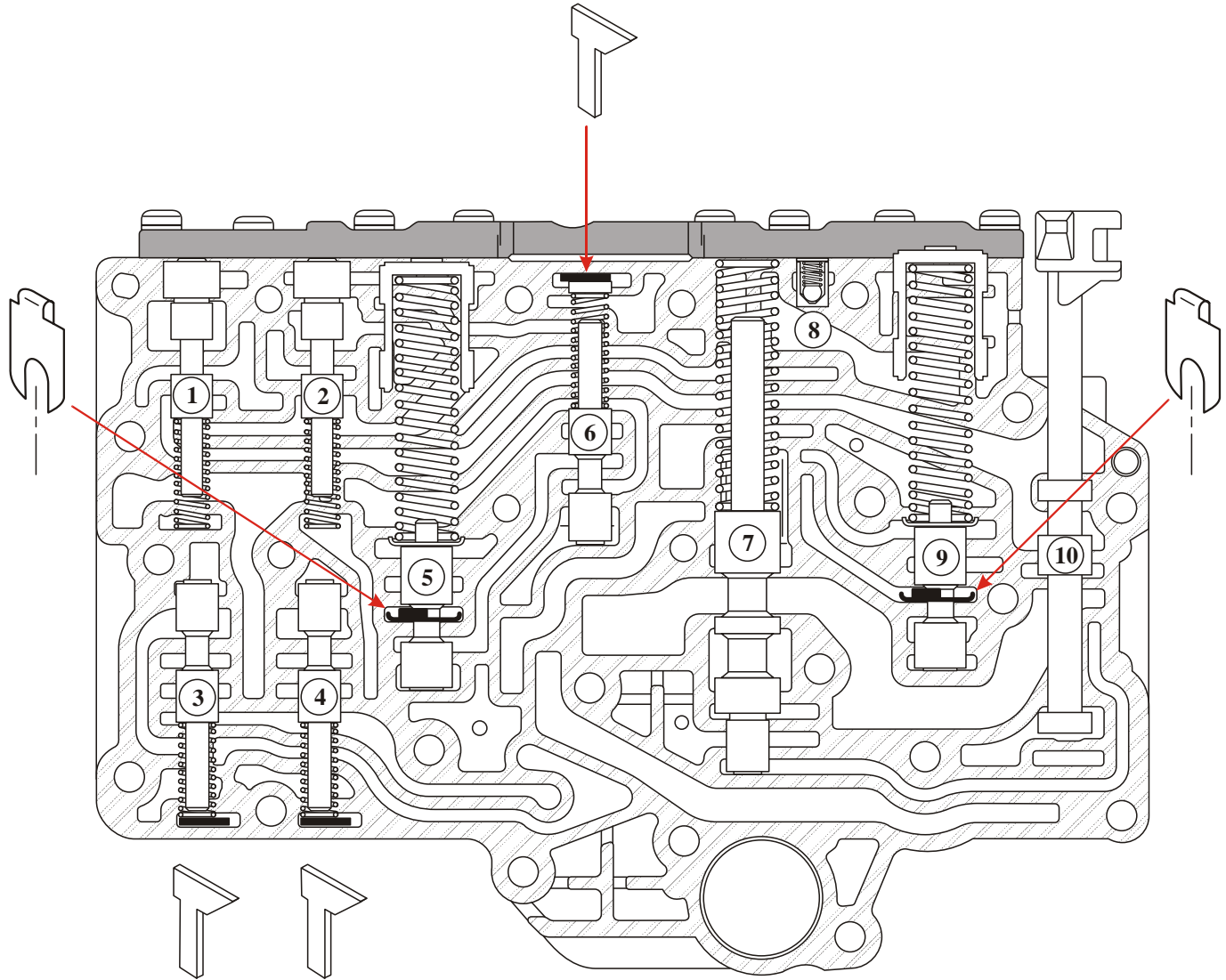

1. "C" CLUTCH ACCUMULATOR REGULATOR VALVE TRAIN LINE-UP
2. "G" CLUTCH ACCUMULATOR REGULATOR VALVE TRAIN LINE-UP
3. "C" CLUTCH SHIFT VALVE TRAIN LINE-UP
4. "G" CLUTCH SHIFT VALVE TRAIN LINE-UP
5. "A" CLUTCH ACCUMULATOR REGULATOR VALVE TRAIN LINE-UP
6. 5-4 TRACTION VALVE TRAIN LINE-UP
7. MAIN PRESSURE REGULATOR VALVE TRAIN LINE-UP
8. "D" CLUTCH ONE-WAY CHECK VALVE ASSEMBLY
9. "E" CLUTCH ACCUMULATOR REGULATOR VALVE TRAIN LINE-UP
10. MANUAL SELECTOR SHIFT VALVE.

Copyright © 2000 ATSG

Figure 16

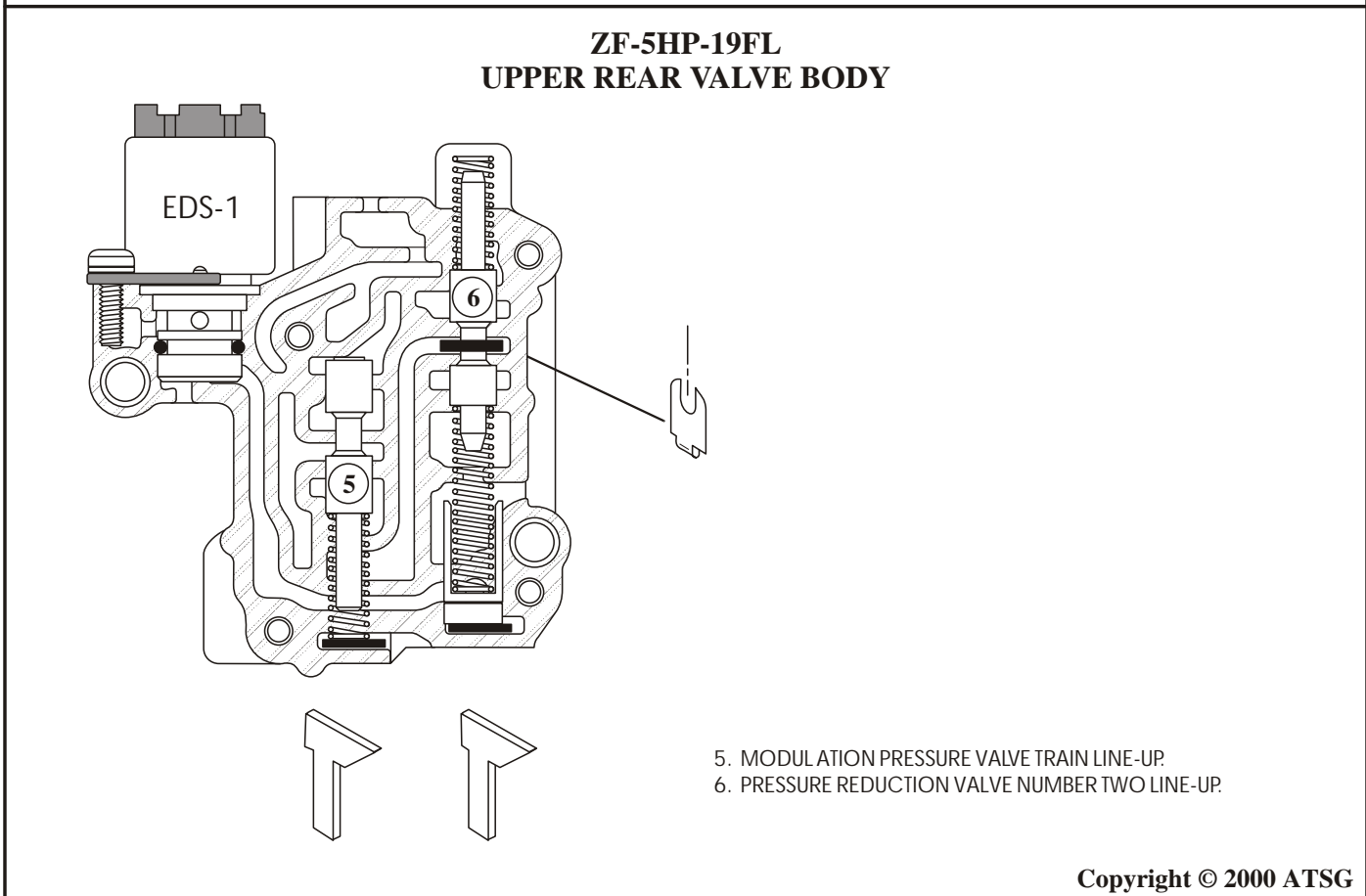
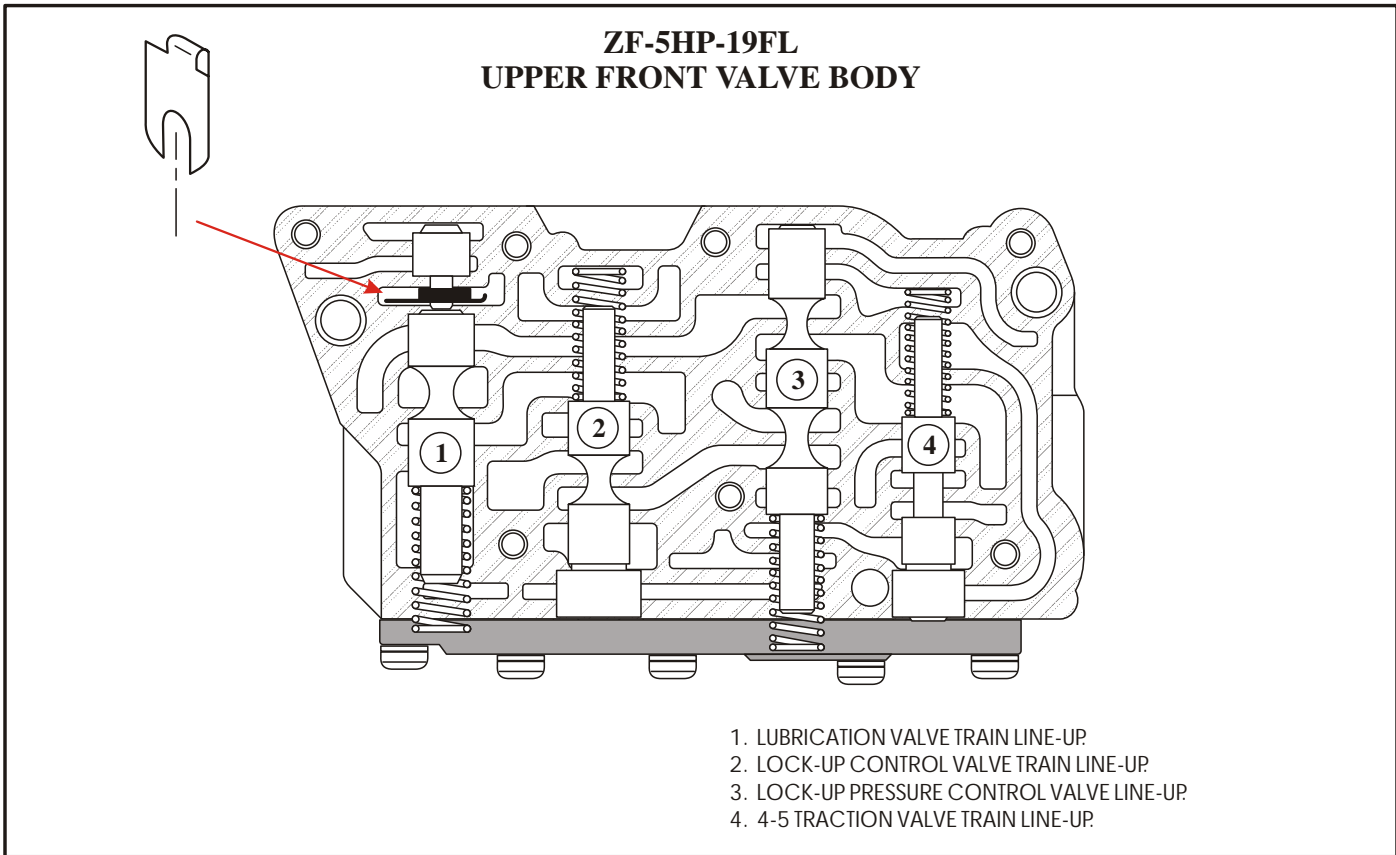

Copyright © 2000 ATSG

Figure 17

ZF-5HP-19FL LOWER REAR VALVE BODY

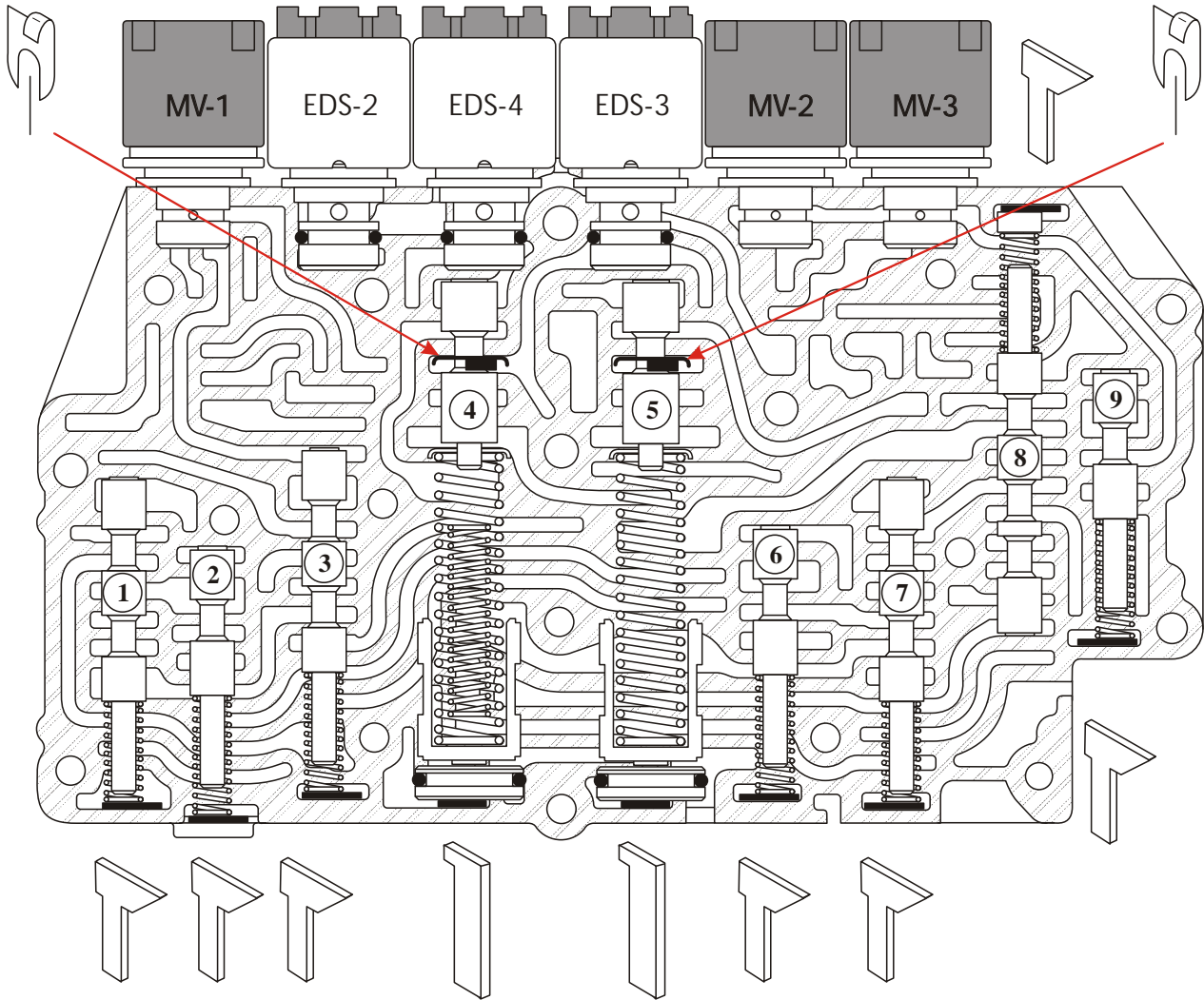

1. TRACTION COAST VALVE TRAIN LINE-UP.
2. TCC RELEASE REGULATOR VALVE TRAIN LINE-UP.
3. NUMBER 3 SHIFT VALVE TRAIN LINE-UP.
4. "D" CLUTCH ACCUMULATOR REGULATOR VALVE TRAIN LINE-UP.
5. "F" CLUTCH ACCUMULATOR REGULATOR VALVE TRAIN LINE-UP.
6. REVERSE GEAR VALVE TRAIN LINE-UP.
7. NUMBER 2 SHIFT VALVE TRAIN LINE-UP.
8. NUMBER 1 SHIFT VALVE TRAIN LINE-UP.
9. PRESSURE REDUCTION VALVE TRAIN LINE-UP.

Copyright © 2000 ATSG

Figure 18

ZF-5HP-19FL CHANNEL PLATE LOCATIONS

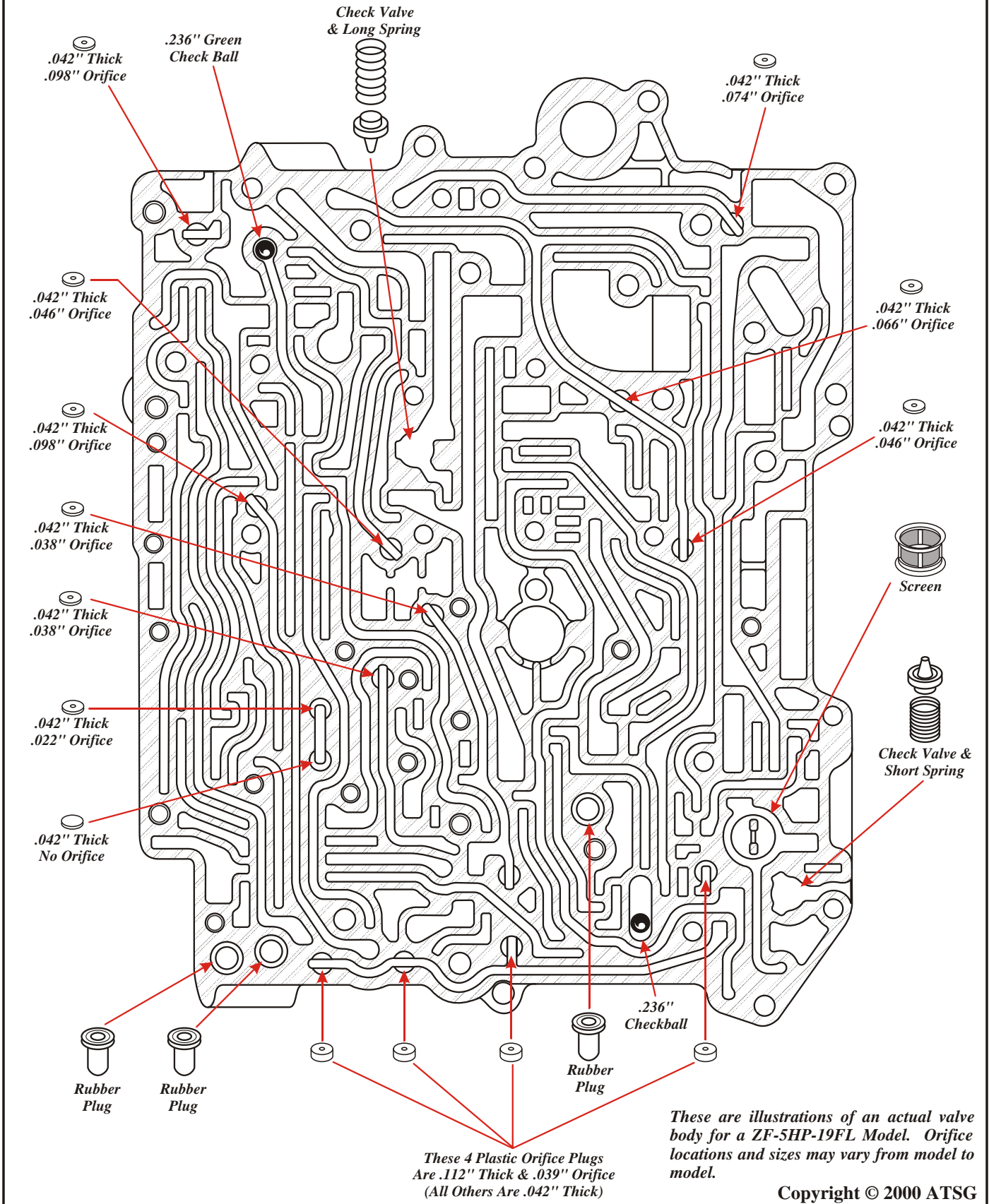

Figure 19