

## RWD 5 Speed

## RWD 5 Speed

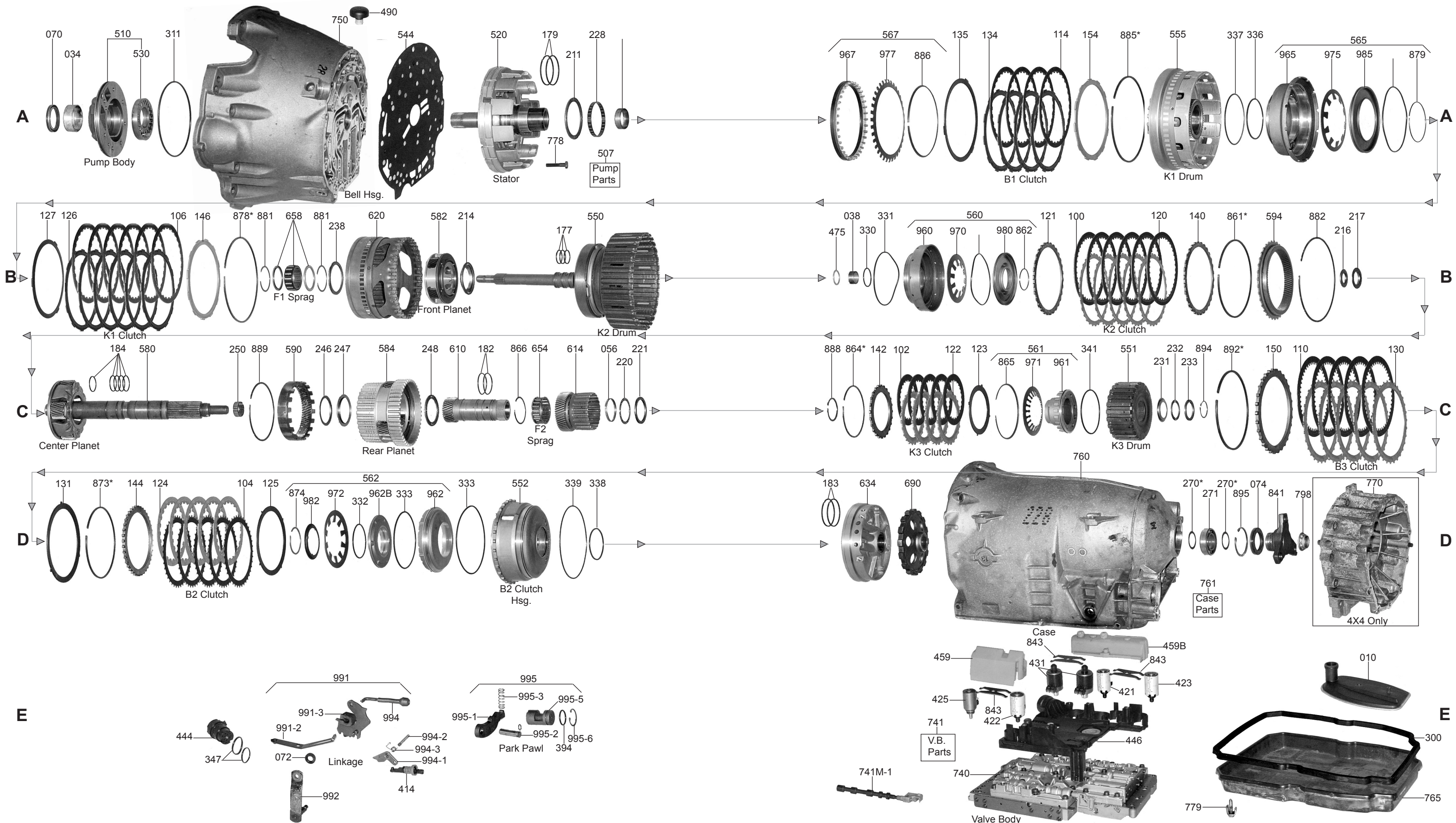

# MERCEDES 722.6

# MERCEDES 722.6

ILL#	PART#	DESCRIPTION	QTY	REF #
		<b>OVERHAUL KIT</b>		
	K68900G	Overhaul Kit, 722.6 W/ B1 Piston & Metal Converter Hsg Gasket 1996-Up	1	
	K68900GX	Overhaul Kit, 722.6 W/ Out B1 Piston & Metal Converter Hsg Gasket 1996-Up	1	
		<b>MASTER L/STEELS KIT</b>		
	DK6800GXS	Master L/Steels Kit, 722.6 (Mercedes) 1996-01 (W /Out B1 Piston & Conv Hsg Gskt)	1	
	DK6800GS	Master L/Steels Kit, 722.6 (Mercedes) 1996-01 (W/ B1 Piston & Conv Hsg Gskt)	1	
	DK6800HXS	Master L/Steels Kit, 722.6 (Merced/Jag) 2002-Up (W/ Out B1 Piston & Conv Hsg Gskt)	1	
	DK6800HS	Master L/Steels Kit, 722.6 (Merced/Jag) 2002-Up (W/ B1 Piston Conv Hsg Gskt)	1	
	DK6800JXS	Master L/Steels Kit, 722.6 (Chrysler/Jeep) 2004-Up (W/ Out B1 Piston & Conv Hsg Gskt)	1	
	DK6800JS	Master L/Steels Kit, 722.6 (Chrysler/Jeep) 2004-Up (W/ B1 Piston & Conv Hsg Gskt)	1	
		<b>MASTER W/STEELS KIT</b>		
	DK6800GX	Master W/Steels Kit, 722.6 (Mercedes) 1996-01 (W /Out B1 Piston & Conv Hsg Gskt)	1	
	DK6800G	Master W/Steels Kit, 722.6 (Mercedes) 1996-01 (W/ B1 Piston & Conv Hsg Gskt)	1	
	DK6800HX	Master W/Steels Kit, 722.6 (Merced/Jag) 2002-Up (W/ Out B1 Piston & Conv Hsg Gskt)	1	
	DK6800H	Master W/Steels Kit, 722.6 (Merced/Jag) 2002-Up (W /B1 Piston & Conv Hsg Gskt)	1	
	DK6800JX	Master W/Steels Kit, 722.6 (Chrys/Jeep) 2004-Up (W/ Out B1 Piston & Conv Hsg Gskt)	1	
	DK6800J	Master W/Steels Kit, 722.6 (Chrysler/Jeep) 2004-Up (W/ B1 Piston & Conv Hsg Gskt)	1	
		<b>FILTERS</b>		
010	68712G	Filter, 722.6 (Mercedes 5 Spd W/Lock-Up) 1996-Up	1	
		<b>BUSHINGS</b>		
034	TBA	Bushing, 722.6 Pump Body (1.690"ID) (Bronze) 1996-Up (Can Use 68002)	1	
034	68002	Bushing, 722.6 Pump Body	1	
034	68004-01	Bushing, 722.6 Pump Body, OE Replacement Size, Sonnax	1	
034	68004-02	Bushing, 722.6 Pump Body, Oversize(Finish In Place), Sonnax	1	
037	68003G	Bushing, 722.6 Stator (Rear) 1.235"ID (Brass) 1996-Up	1	
037	68915-01	Bushing, 722.6 Stator (Rear) OE Replacemant Size, 1996-Up Sonnax	1	
038	68010G	Bushing, 722.6 (Mercedes) K2 Drum (Rear) (.915"ID) 1996-Up	1	
038	68410-01	Bushing, 722.6 K2 Clutch Drum, OE Replacemant Size, 1996-Up Sonnax	1	
038	68423G	Use 68423G	1	
215	68423G	Caged Needle Bearing, 722.6 (Chrysler) K2 Drum (Rear) (Cast # HK2210) 2004-Up	1	
215	68410-02K	Caged Needle Bearing & Seal Kit, 722.6 K2 Drum (1-Needle Bearing, 1-Teflon Seal)	1	Sonnax
038	K68010G	Bushing Set, 722.6 (Mercedes) K2 Drum (Rear) (1 Stock Bsh .915"ID And 1 Oversized Bushing) (Oversized! Bsh For The Only Output Shaft Mercdes Offers New	1	
056	68017G	Bsh, 722.6 (Mercedes) Rear Sun Gear (.188" Wide) 1996-Up (2.999"OD) (Split, Brass)	1	
		<b>METAL CLAD SEALS</b>		
070	68161	Seal, 722.6 Front 1996-Up	1	
072	68165	Seal, 722.6 Linkage Shaft (.710"ID) 1996-Up	1	
074	68165G	Seal, 722.6 Ext Housing / Rear (.322" Thick) (2.445"OD) 1996-Up	1	
		<b>FRICION CLUTCH</b>		
100	68106G	Fri, 722.6 (Merced) K2 Cl (.085") 36T (6 1/2"OD, Small ID) W/ 3 Gr Rear Planet 1996-Up	5	210-272-00-25

100	68106H	Friction, 722.6 K2 Cl (.085") 36T (6 1/2"OD, Large ID) W/ 4 Gr Rear Planet, 1996-Up	6	140-272-01-25
102	68132H	Friction, 722.6 (Mercedes) K3 Clutch (.087") 24 Teeth (2 Sided) 1996-Up	3	
102	68132GA	Friction, 722.6, 1-Sided (Chrysler) K3 Clutch (.082") 24 Teeth Internal 2004-Up	5	
104	68132G	Friction, 722.6 B2 Clutch (.064") 40 External Teeth (5.215"ID) 1996-Up	5	
106	68105G	Use 68105G	6	
106	68105GA	Use 68105GA	6	
110	68107G	Friction, 722.6 B3 Clutch (.065") 46 Teeth (7 1/8"OD) 1996-Up	5	
114	68105G	Friction, 722.6 (Mercedes) B1 Cl (Also K1) (.085") 30T (6 3/16"OD) 1996-Up	10	
114	68105GA	Friction, 722.6 (Chrys) B1 Cl (Also K1) (.081") 30T Inner, 1 Sided (6 3/16"OD) 2004-Up	10	
119	K68GF	Friction Module, 722.6 (With Large ID K2 Friction, For A 4 Gear Rear Planet) 1996-01	1	
119	K68GAF	Friction Module, 722.6 (With Small ID K2 Friction, For A 3 Gear Rear Planet) 1996-01	1	
119	K68HF	Friction Module, 722.6 (With Large ID K2 Friction, For A 4 Gear Rear Planet) 2002-Up	1	
119	K68HAF	Friction Module, 722.6 (With Small ID K2 Friction, For A 4 Gear Rear Planet) 2002-Up	1	
119	K68JF	Friction Module, 722.6, Chrysler Nag-1 With 5.7L & 6.1L "Hemi" Engines 2000-Up	1	
		<b>STEEL CLUTCH</b>		
120	68119A	Steel, 722.6 (Mercedes) K2 Clutch (.138") 30 Teeth (5.755"ID) 1996-Up	3	
120	68119B	Steel, 722.6 (Chrysler) K2 Clutch (.110") 30 Teeth (5.755"ID) 2004-Up	4	
121	68119	Steel, 722.6 K2 Clutch (.071") 30 Teeth (Bottom) 1996-Up	1	
121	68137C	Cushion, 722.6 (Chrysler) K2 Clutch (.077") 3 Teeth (Goes Under # 121A) 2004-Up	1	
122	68120B	Steel, 722.6 (Mercedes) K3 Clutch (.109") (24 Teeth) 1996-Up	4	
122	68120	Steel, 722.6 (Mercedes) K3 Clutch (.070") (24T) 1996-Up (This Is The Bottom Steel)	1	
122	68120A	Steel, 722.6 (Mercedes) K3 Clutch (.138") (24 Teeth) 1996-97	4	141709-350
122	68120GA	Friction, 1-Sided, 722.6 (Chrysler) K3 Clutch (.082") (24 Teeth External) 2004-Up	4	
123	68138C	Cushion, 722.6 K3 Clutch (.067") 4 Teeth (3.455"ID) 1996-Up	1	
124	68122	Steel, 722.6 B2 Clutch (.070") 24 Internal Teeth (6 1/8"OD) 1996-Up	4	
124	68122G	Steel, 722.6 B2 Clutch (Bottom) .069" (40 External Teeth) 1996-Up (5.215"ID)	1	
125	68141	Cushion, 722.6 B2 Clutch (.080") (4 External Teeth) 1996-Up	1	
126	68118	Use 68118	6	TBA
126	68118C	Use 68118C	6	TBA
126	68118GA	Use 68118GA	6	TBA
127	68139	Use 68139	1	TBA
130	68123	Steel, 722.6 B3 Clutch (.070") 30 Teeth (6 1/8"OD) 1996-Up	5	
131	68143	Cushion, 722.6 B3 Clutch (Bottom) .109" (3 Teeth) 6 1/8"ID 1996-Up	1	
134	68118	Steel, 722.6 (Mercedes) B1 Cl (Also K1 Cl) (.071") 12T (Bottom) 6.063"ID 1996-Up	2	
134	68118C	Steel, 722.6 (Mercedes) B1 Cl (Also K1 Cl) (.138") 12T (Middle) 1996-Up (6.063"ID)	2	
134	68118GA	Friction, 1-Sided (Chrysler) B1 Cl (Also K1 Cl) (.082", 6.063"ID) 12T Outer) 2004-Up	5	
135	68139	Cushion, 722.6 B1 Cl (Also K1 Cl) (.061") 3 Teeth (6.067"ID) 1996-Up	2	
		<b>PRESSURE PLATES</b>		
140	68137	Pressure Plate, 722.6 K2 Clutch (.156") 30 Teeth (5.765"ID) 1996-Up	1	TBA
142	68138	Pressure Plate, 722.6 K3 Clutch (Top) .155" (24 Teeth) 3.465"ID 1996-Up	1	TBA
144	68140	Pressure Plate, 722.6 B2 Clutch (Top) .255" (40 Teeth) 5.210"ID 1996-Up	1	TBA
146	68136B	Use 68136B	1	TBA
150	68142	Pressure Plate, 722.6 B3 Clutch (Top) .255" (30 Teeth) 6 1/8"ID 1996-Up	1	

# MERCEDES 722.6

# MERCEDES 722.6

154	68136B	Pressure Plate, 722.6 B1 Cl (Also K1 Cl) (.156") 12 Teeth (6.063"ID) 1996-Up	2	TBA
		<b>SEALING RINGS</b>		
	K68904G	Ring Kit, 722.6, 1996-Up		
177	68307G	Ring, 722.6 (Mercedes) Input Shaft (Scarf Cut) (Teflon) 1996-Up	3	TBA
177	68307GA	Ring, (Chrysler) Input Shaft, Lap Joint (Like A Mortise & Tinno Joint) (Teflon) 2004-Up	3	TBA
179	68303G	Ring, 722.6 Stator To K1 Drum (Teflon) 1996-Up	3	TBA
182	TBA	O-Ring, 722.6 Center Sun Gear 1996-Up	2	TBA
183	TBA	O-Ring, 722.6 B2 Clutch Housing Support 1996-Up	2	TBA
184	68310G	Ring, 722.6 (Mercedes) Output Shaft (Scarf-Cut) (Teflon) 1996-Up	5	TBA
184	68310GA	Ring, 722.6 (Chrysler) Output Shaft (Lap Joint) (Teflon) 2004-Up	5	TBA
		<b>WASHERS &amp; BEARINGS</b>		
211	68459G	Brng W/Race, 722.6 Stator To K1 Drum (.119" Thk, 3.42"OD, 2.72"ID) 1996-Up	1	TBA
214	TBA	Bearing W/Race, 722.6 (Mercedes) Front Planet To K2 Drum 1996-Up (No Tabs)	1	TBA
214	TBA	Bearing W/Race, 722.6 (Chrysler) Front Planet To K2 Drum (2 Outer Tabs) 2004-Up	1	TBA
215	68423G	Caged Needle Bearing, 722.6 (Chrysler) K2 Drum (Rear) (HK2210) 2004-Up	1	TBA
216	TBA	Race, 722.6 K2 Drum To Center Planet (1.686"OD) 1996-Up	1	TBA
217	TBA	Bearing, W/Race, 722.6 K2 Drum To Center Planet (1.755"OD) 1996-Up	1	TBA
220	TBA	Brng, (Merced) Rear Sun Gr To K3 Drum (.078" Thk, 1.905"ID, 2.403"OD) 1996-Up	1	TBA
220	TBA	Race, (Chrys) Rear Sun Gr To Brng #221 (.038" Thk, 1.915"ID, 2.553"OD) 2004-Up	1	TBA
221	TBA	Race, (Merced) Rear Sun Gr To K3 Drum (.125" Thk, 1.095"ID, 2.395"OD) 1996-Up	1	TBA
221	TBA	Ball Bearing, (Chrysr Rear Sun Gr To K3 Drum(Cast # INA A210 981 03 25) 2004-Up	1	TBA
228	TBA	Caged Needle Brng, 722.6 Stator (Outer) To K1 Drum, .307" Wide, 2.70"OD, 1996-Up	1	TBA
231	TBA	Race, Center Sun Gr To B2 Cl Hsg (Stepped) 1.77" Thk, 1.405"ID, 2.198"OD, 1996-Up	1	TBA
232	TBA	Bearing, 722.6 Center Sun Gear To B3 Cl Hsg (.078") 1.385"ID, 1.84"OD, 1996-Up	1	TBA
233	TBA	Race, (Mercedes) Center Sun Gr To B2 Cl Hsg (.121", 1.386"ID, 1.822"OD, 1996-Up	1	TBA
233	TBA	Race, (Chrysler) Center Sun Gr To B2 Cl Hsg, .132", 1.386"ID, 1.822"OD, 2004-Up	1	TBA
238	TBA	Brng W/Race, (Merced) K1 Drum To Front Planet, .110", 2.922"OD, 2.347"ID 1996-Up	1	
238	TBA	Brng, 722.6 (Chrys) K1 Drum To Front Planet, .078", 2.859"OD, 2.347"ID, 2004-Up	1	
246	TBA	Race, (Mercedes) Center Planet To Rear Planet, .031", 2.744"OD, 2.235"ID, 1996-Up	1	
246	TBA	Race, 722.6 (Chrys) Center Planet To Rear Planet, .031", 2.554"OD, 2.045"ID, 2004-Up	1	
247	TBA	Brng W/Race, (Merced) Center Plan To Rear Plan (.110", 2.850"OD, 2.238"ID) No Tabs	1	
247	TBA	Brng W/Race, (Chrys) Center Plan To Rear Plan(.110", 2.670"OD, 2.053"ID, 2 Tab 2004-	1	
248	TBA	Brng W/Race, (Merced) Rear Plan To Rear Sun Gr, .136", 2.985"OD, 2.235"ID, 1996-	1	
248	TBA	Brng W/Race, (Chrys) Rear Plan To Rear Sun G, .136", 2.985"OD, 2.06" ID, 2 Tab, 2004-	1	
250	68413G	Split Caged Needle Bearing, 722.6 Output Shaft (Plastic) 1996-Up	1	
270	TBA	Shim, Park Gear To Rear Case Ball Brg (*Specify Thickness .008" To .020") 1996-Up	1	
271	68462G	Ball Brng, Case To Output Shaft (Cast # 140 981 01 25, INA 6206E A HO1)1996-Up	1	
		<b>GASKETS &amp; RUBBER COMPONENTS</b>		
300	68501G	Gasket, 722.6 Bottom Pan 1996-UP	1	
311	68506G	O-Ring, 722.6 Pump Body To Bell 1996-Up	1	
371	TBA	Boot, 722.6 (Chrysler) Filler Tube 2004-Up	1	
NI	68410GA	O-Ring, 722.6, Electrical Connector, Large, 1996-04 (Updated Design)	1	
NI	68410GB	O-Ring, 722.6, Electrical Connector, Small, 1996-04 (Updated Design)	1	
NI	68410HA	O-Ring, 722.6, Electrical Connector, Large, 2005-Up	1	
NI	68410HB	O-Ring, 722.6, Electrical Connector, Small, 2005-Up	1	

		<b>TECHNICAL MANUALS</b>		
400	TMMBZ6	Tech Manual And Video, 722.6 1996-Up	1	TBA
		<b>ELECTRICAL COMPONENTS</b>		
421	68956	Solenoid, 722.6 1-2/4-5 Shift (2 O-Ring Type) 1996-Up	4	
422	68956	Solenoid, 722.6 Shift, 2-3 1996-Up	1	
423	68956	Solenoid, 722.6 Shift, 3-4 1996-Up	1	
425	68957	Solenoid, 722.6 Lock-Up (PWM) (1 O-Ring Type) 1996-Up	1	
431	68954	Solenoid, 722.6 Modulating Pressure & Shift Pressure Regulating, No O-Rings, 1996-Up	1	
444	68981G	Connector, 722.6 Valve Body To Case (Plastic, 13 Pin Holes, 1 Bolt, 2 O-Rings, 1996-UP	1	
446	TBA	Conductor Plate, 722.6 Valve Body 1996-Up	1	
459	TBA	Cover, 722.6 Solenoid (The 2 Solenoid Cover) 1996-Up	1	
459	TBA	Cover, 722.6 Solenoid (The 4 Solenoid Cover) 1996-Up	1	
	68970	Electronic Control Module, 722.6, 1996-Up	1	
		<b>MISCELLANEOUS COMPONENTS</b>		
475	TBA	Teflon Sleeve, 722.6 (Chrysler) Under #215 Bearing In K2 Drum 2004-Up	1	TBA
490	TBA	Vent, 722.6 (Mercedes) Bell Housing (Round Plastic) 1996-Up	1	
490	TBA	Vent, 722.6 (Chrysler) Bell Housing (Plastic Elbow) 2004-Up	1	
		<b>HARD PARTS</b>		
510	68913G	Pump Body W/Gears, 722.6 (5.980"OD) (Cast Iron) 1996-Up	1	
520	68916G	Stator, 722.6 (Mercedes) Uses 2ea 2-Sided Fric On Rear (Cast# 140 272 10 24) 1996-Up	1	
520	68916GA	Stator, 722.6 (Mercedes) Uses 3ea 2-Sided Fric On Rear (Cast# 140 272 10 24) 1996-Up	1	
520	68916GB	Stator, 722.6 (Mercedes) Uses 4ea 2-Sided Fric On Rear (Cast# 140 272 10 24) 1996-Up	1	
520	68916J	Stator, 722.6 (Chrys) Uses 3ea 1-Sided Frictions On Rear Cast# 140 272 22 24) 2004-Up	1	
		<b>PUMP COMPONENTS</b>		
530	K68201G	Pump Gear Set, 722.6 (.503" Thk) 19T Inner (23T Outer)(2 Drive Lugs For Conv) 1996-Up	1	
544	68920G	Plate, 722.6 (Mercedes) Pump (68 Holes Total) 1996-Up	1	140-277-4214
544	68920J	Plate, 722.6 (Chrysler) Pump (69 Holes Total) 2004-Up	1	
		<b>HARD PARTS (Continued)</b>		
550	68932G	Drum W/Shaft, (Mercedes) K2 (W/ 90T Ring Gr) Has A Bushing Inside Rear, 1996-Up	1	
550	68932GA	Drum W/Shaft, (Merced) K2 (W/ 90T Ring Gr) Needll Brng & Tefl Sleeve In Rear, 96-Up	1	
550	68932GB	Drum W/Shaft, (Merced) K2 (W/ 78T Ring Gr) Has Bushing Inside Rear, 1996-Up	1	
550	68932J	Drum W/Shaft, (Chrys) K2 (W/ 78T Ring Gr) Has Needl Brng & Tefl Sleeve In Rear, 04-Up	1	
551	68732G	Drum, 722.6 (Mercedes) K3 Clutch (3 Clutch) 1996-Up	1	
551	68732J	Drum, 722.6 (Chrysler) K3 Clutch (4 Clutch) 2004-Up	1	
552	68733G	Housing, 722.6 (Merced) B2 Cl (Cast # 202 272 04 31) Aluminum, 3.495" Thk, 1996-Up	1	
552	68733J	Housing, 722.6 (Chrysl) B2 Cl (Cast # 210 272 19 31) Aluminum, 3.180" Thk, 2004-Up	1	
555	68922G	Drum, (Merced) K1 Cl (3-Cl) W/50T Sun Gr, Uses 2-Sided Fric, (#R140 272 00 24) 1996-	1	
555	68922J	Drum, (Chrys) K1 Cl (5-Cl) W/58T Sun Gr, Uses 1-Sided Fric (#R140 272 11 24) 2004-	1	
580	68749G	Planet W/Shaft, 722.6 (Mercedes) Center (34T Sun Gr) (.905" Front Pilot) 1996-Up	1	
580	68749J	Planet W/Shaft, 722.6 (Chrys) (4x4) Center (30T Sun Gr) (.870" Front Pilot) 2004-Up	1	
582	68924G	Planet, 722.6 (Mercedes) Front (3 Gear Aluminum) (50 Teeth Sun Gear) 1996-Up	1	
582	68924J	Planet, 722.6 (Chrysler) Front (4 Gear Aluminum) (58 Teeth Sun Gear) 2004-Up	1	

# MERCEDES 722.6

# MERCEDES 722.6

583	K68924G	Planet Ass'y, 722.6 (Mercedes) Uses 34 Teeth Sun Gear #610 (.905"OD Pilot # 580) (#584 IS 4.02" Tall With 16T Gears)(#594 Is 5 1/2"ID)(Includes: # 594,580, 250, 889, 590, 246, 247, 584, 610, 866, 654, 614, 056, 220, 221 & 888)	1	
583	K68924GA	Planet Assembly, 722.6 (Mercedes) 34 Teeth Sun Gear # 610 (.905"OD Pilot #580) (#584 Is 4.270" Tall With 19T Gears) (#594 Is 5 3/4"ID) (Includes: 594, 580, 250, 889, 590, 246, 247, 584, 248, 610, 866, 654, 614, 056, 220, 221 & 888)	1	
583	K68924GB	Planet Assembly, 722.6 (Mercedes) 34 Teeth Sun Gear # 610 (.629"OD Pilot # 580) (#584 Is 4.02" Tall With 16T Gears) (#594 Is 5 1/2"ID) (Includes: 594, 580, 250, 889, 590, 246, 247, 584, 248, 610, 866, 654, 614, 056, 220, 221 & 888)	1	
583	K68924GC	Planet Assembly, 722.6 (Mercedes) (34 Teeth Sun Gear #610)(.866"OD Pilot #580) (#584 Is 4.02" Tall With 16T Sun Gears)(#594 Is 5 1/2"ID) (Includes # 594, 580, 250, 889, 590, 246, 247, 584, 248, 610, 866, 654, 614, 056, 220, 221 & 888)	1	
583	K68924J	Planet Ass'y, 722.6 (Chrysler) (4x4) 30T Sun Gear #610 (.870"OD Pilot #580) (Includes: (594, 580, 250, 889, 590, 246, 247, 584, 248, 610, 866, 654, 614, 056, 220, 221, 888	1	
584	68926G	Planet, 722.6 (Mercedes) Rear (3 Gear) 34 Teeth Sun Gear (Aluminum Housing) (No Notches For # 247) (4.02" Tall) (16 Teeth Pinions) 1996-Up	1	
584	68926J	Planet, 722.6 (Chrys) Rear (4 Gr) 30T Sun Gr (Alum Hsg) 2 Notches For #247, 2004-Up	1	
590	68759G	Ring Gear, 722.6 (Mercedes) Center Planet (69 Teeth) 18 Lugs (1.160" Wide) 1996-Up	1	
590	68759J	Ring Gear, 722.6 (Chrysler) Center Planet (74 Teeth) 18 Lugs (1.240" Wide) 2004-Up	1	
594	68758G	Ring Gear, 722.6 (Mercedes) Rear Planet (87 Teeth) 36 Outer Lugs (5 1/2"ID) 1996-Up	1	
594	68758GA	Ring Gear, 722.6 (Mercedes) Rear Planet (90 Teeth) 36 Outer Lugs	1	
594	68758J	Ring Gear, 722.6 (Chrysler) Rear Planet (108 Teeth) 36 Outer Lugs 2004-Up	1	
610	68756G	Sun Gear, 722.6 (Mercedes) Center Planet (34 Teeth) 1996-Up	1	
610	68756J	Sun Gear, 722.6 (Chrysler) Center Planet (30 Teeth) 2004-UP	1	
614	68927G	Sun Gear, (Merced) Rear Planet (54T) 24T CI Hub, 3.015" Long, Has Bsh Inside, 1996-	1	
614	68927J	Sun Gear, (Chrys) Rear Planet (60T) 24T CI Hub,3.015" Long, Has Brng Inside, 2004-Up	1	
620	68748G	Shell, 722.6 (Mercedes) Driving (For 3 Gear Front Planet) 1996-Up	1	
620	68748J	Shell, 722.6 (Chrysler) Driving (For 4 Gear Front Planet) 2004-Up	1	
634	68933G	Support, B2 CI Hsg (Cast # 140 272 06 32) Alum W/ Steel Sleeve, 6-11/16" OD, 1996-	1	
<b>SPRAGS &amp; ONE WAY CLUTCHES</b>				
654	68727G	Sprag, 722.6 (Mercedes) F2 (Rear) (14 Elements) 1996-Up	1	
654	68727J	Sprag, 722.6 (Chrysler) F2 (Rear) (20 Elements) 2004-Up	1	
658	68724G	Sprag W/End Washers, 722.6 (Mercedes) F1 (16 Elements) 1996-Up	1	
658	68724J	Sprag W/End Washers, 722.6 (Chrysler) F1 (20 Elements) 2004-Up	1	722-270-0031
<b>HARD PARTS (Continued)</b>				
690	68937G	Parking Gear, 722.6 (16 Lugs) (6.062"OD) 1996-Up	1	
<b>VALVE BODIES</b>				
740	68924G	Valve Body, 722.6 (Mercedes) With 6 Solenoids (Cast # 140 277 36 01) 1996-Up	1	
740	68924J	Valve Body, 722.6 (Chrysler) With 6 Solenoids (Cast # 52108216AA) 2004-Up	1	
<b>VALVE BODY COMPONENTS</b>				
741	68942-01	Spring, 722.6 Solenoid Pressure Regulator (Sonnax)	1	
<b>HARD PARTS (Continued)</b>				

750	68703G	Bell Hsg, (Merc) 4 5/8" Top Bolts (Square Top) Starter At 3:00 (#R210 271 09 01) 1996-	1	
750	68703GA	Bell Hsg, (Merc) 5 3/4" Top Bolts (Round Top) Starter 3:00 & 9:00( #R140 271 27 01) 96-	1	
750	68703GB	Bell Hsg, (Merc) 6" Top Bolts (Round Top) Starter 3:00 & 9:00 (#210 271 08 01) 1996-	1	
750	68703J	Bell Housing, 722.6 (Chrysler) 8 3/4" Top Bolts (Round Top) 2004-Up (Starter At 3:00) Cast # 435AA-1, 29340287, 521084030)	1	
760	68941G	Case, 722.6 (Mercedes) 2WD (5/8"OD Filler Tube Hole) (Cast # 140 27 28 01) 1996-Up	1	
760	68941GA	Case, 722.6 (Mercedes) 2WD (5/8"OD Filler Tube Hole) (Cast # 901 271 00 01) 1996-Up	1	
760	68941J	Case, 722.6 (Chrys) 4x4 (1 3/16"OD Filler Tube) 2004-Up (12 Bolt For Ext Hsg Adapter)	1	
760	68941JA	Case, (Chrysler) 2WD (1 3/16"OD Filler Tube Hole) 2004-Up (Cast # 103AA-03 Or -E	1	
765	68934G	Pan, 722.6 (Mercedes) Bottom (With Drain Plug) 1996-Up	1	
765	68934J	Pan, 722.6 (Chrysler) Bottom (No Drain Plug) 2004-Up	1	
770	68939J	Ext Hsg Adapter, 722.6 (Chrys 4x4 (Alum) (4 13/16" Long) 2004-Up (Cast # 52108571AA)	1	
798	TBA	Nut, 722.6 Yoke To Output Shaft (12 Point) 1996-Up	1	
841	TBA	Yoke, (Mercedes) 2WD Output Shaft (3 Bolt) 1.65"OD At Seal Surface, 1996-Up	1	
841	TBA	Yoke Sleeve, 722.6 (Chrys) 4x4 Output Shaft To Trans Case (1.65"OD At Seal) 2004-Up	1	
960	68675G	Piston, 722.6 (Mercedes) K2 Clutch (1.775" Thick) (Steel) 1996-Up	1	
960	68675J	Piston, 722.6 (Chrysler) K2 Clutch (1.495" Thick) (Steel) 2004-Up	1	
961	68762G	Piston, 722.6 K3 Clutch (Aluminum) (Cast # 140 272 19 31) 1996-Up	1	
962	68764G	Piston, B2 CI (Outer) (Cast # 140 272 20 31) 1.375" Thk, 3.15"ID, 5.90"OD, 1996-Up	1	
962	68764GA	Piston, B2 CI (Inner) (Cast # 140 272 07 32) 8.0" Thk, 2.40"ID, 4.70"OD W/ Chk Ball, 96-Up	1	
965	68763G	Piston, 722.6 K1 Clutch (Aluminum) 2.205" Thick (Cast # 140 272 1431) 1996-Up	1	
967	68765G	Piston, (Merc) B1 CI (Bonded) .700" Thk (6 5/8"OD) 36 Legs, Uses 2-Sided Fri, 96-Up	1	
967	68765J	Piston, (Chrys) B1 (Bonded) .877" Thk (6 5/8"OD) 36 Legs, Uses 1-Sided Fri, 04-Up	1	
970	TBA	Spring, 722.6 K2 Clutch Piston Return (10 Fingers) 1996-Up	1	
971	TBA	Spring, 722.6 K3 Clutch Piston Return (20 Fingers) 1996-Up	1	
972	TBA	Spring, 722.6 B2 Clutch Piston Return (10 Fingers) 1996-Up	1	
975	TBA	Spring, 722.6 K1 Clutch Piston Return (10 Fingers) 1996-Up	1	
977	TBA	Spring, 722.6 B1 Clutch Return (36 Outer Fingers) (.053"Thick) 1996-Up	1	
980	TBA	Retainer, 722.6 K2 Piston (Steel) (4.545"OD) 1996-Up	1	
982	TBA	Retainer, 722.6 B2 Clutch Piston Spring (2 Tabs) 1996-Up	1	
985	TBA	Retainer, 722.6 K1 Clutch Return Spring (5.176"OD) 1996-Up	1	
991	TBA	Linkage Assembly, 722.6 (Mercedes) Internal (7 Pieces With Sensor) 1996-Up	1	
991	TBA	Linkage Assembly, 722.6 (Chrysler) (4 Pieces, No Sensor) 2004-Up	1	
992	TBA	Shift Lever, 722.6 (Mercedes) External (Straight With Grommet) 1996-Up	1	
992	TBA	Shift Lever, 722.6 (Chrysler) External (Off Set With Grommet) 2004-Up	1	
995	K68937G	Park Pawl Assembly, 722.6 (5 Pieces) 1996-Up	1	