

42LE TRANSAXLE

TABLE OF CONTENTS

	page		page
DESCRIPTION AND OPERATION		FLUID DRAIN AND REFILL-DIFFERENTIAL	
42LE TRANSAXLE	2	SUMP	31
FLUID REQUIREMENT	4	ALUMINUM THREAD REPAIR	31
TORQUE CONVERTER	4	FLUSHING COOLERS AND TUBES.....	31
OIL PUMP.....	5	OIL PUMP VOLUME CHECK.....	32
VALVE BODY.....	6	TRANSAXLE QUICK LEARN PROCEDURE	33
ACCUMULATORS	7	PINION FACTOR PROCEDURE	33
INPUT CLUTCHES	8	REMOVAL AND INSTALLATION	
HOLDING CLUTCHES.....	9	GEARSHIFT CABLE-COLUMN SHIFT	33
PLANETARY GEARTRAIN	10	GEARSHIFT CABLE-FLOOR SHIFT.....	36
DIFFERENTIAL	10	FLOOR SHIFTER.....	38
TRANSMISSION CONTROL MODULE	10	INTERLOCK CASSETTE	39
TRANSMISSION CONTROL RELAY	13	BRAKE TRANSMISSION SHIFT INTERLOCK	
SOLENOID/PRESSURE SWITCH ASSEMBLY ...	14	SOLENOID (COLUMN).....	40
TRANSMISSION RANGE SENSOR.....	15	BRAKE/TRANSMISSION SHIFT INTERLOCK	
SHIFT POSITION INDICATOR.....	16	CABLE (FLOOR).....	43
INPUT SPEED SENSOR	16	TRANSMISSION RANGE SENSOR	45
OUTPUT SPEED SENSOR.....	17	INPUT SPEED SENSOR	46
BRAKE TRANSMISSION SHIFT INTERLOCK		OUTPUT SPEED SENSOR.....	46
SYSTEM (FLOOR SHIFT).....	18	TRANSMISSION CONTROL MODULE	47
BRAKE TRANSMISSION SHIFT INTERLOCK		TRANSMISSION CONTROL RELAY	48
SYSTEM (COLUMN SHIFT).....	18	SOLENOID/PRESSURE SWITCH ASSEMBLY ...	48
AUTOSTICK.....	19	VALVE BODY.....	48
DIAGNOSIS AND TESTING		TRANSAXLE	50
42LE GENERAL DIAGNOSIS.....	20	OIL PUMP SEAL REPLACEMENT.....	52
ROAD TEST	20	TRANSFER SHAFT SEAL REPLACEMENT	53
HYDRAULIC PRESSURE TESTS.....	21	LONG STUB SHAFT SEAL REPLACEMENT	54
CLUTCH AIR PRESSURE TESTS	23	SHORT STUB SHAFT SEAL REPLACEMENT ...	55
FLUID LEAKAGE.....	24	DISASSEMBLY AND ASSEMBLY	
FLUID LEAKAGE-TORQUE CONVERTER		VALVE BODY.....	57
HOUSING AREA.....	25	TRANSAXLE-DISASSEMBLY	65
BRAKE/TRANSMISSION SHIFT INTERLOCK		OIL PUMP.....	83
SYSTEM (COLUMN SHIFT).....	26	INPUT CLUTCH ASSEMBLY	84
BRAKE/TRANSMISSION SHIFT INTERLOCK		TRANSAXLE-ASSEMBLY	101
SYSTEM (FLOOR SHIFT).....	27	DIFFERENTIAL RECONDITION	119
SHIFT POSITION INDICATOR.....	28	CLEANING AND INSPECTION	
AUTOSTICK.....	28	TRANSFER CHAINS LENGTH	
SERVICE PROCEDURES		MEASUREMENT	140
FLUID LEVEL AND CONDITION CHECK.....	29	ADJUSTMENTS	
FLUID AND FILTER SERVICE—		GEARSHIFT CABLE-COLUMN SHIFT	141
TRANSMISSION	29	GEARSHIFT CABLE-FLOOR SHIFT.....	141

BRAKE/TRANSMISSION SHIFT INTERLOCK (FLOOR)..... 142
 AUTOSTICK..... 143
 BEARING ADJUSTMENT PROCEDURES 143
 MASTER SHIM CHART..... 143
 DRIVE SPROCKET HEIGHT ADJUSTMENT PROCEDURE 145

SCHEMATICS AND DIAGRAMS
 42LE TRANSAXLE HYDRAULIC SCHEMATICS. 146
SPECIFICATIONS
 42LE AUTOMATIC TRANSAXLE 159
 42LE TRANSAXLE TORQUE SPECIFICATIONS. 159
SPECIAL TOOLS
 42LE AUTOMATIC TRANSAXLE 160

DESCRIPTION AND OPERATION

42LE TRANSAXLE

DESCRIPTION

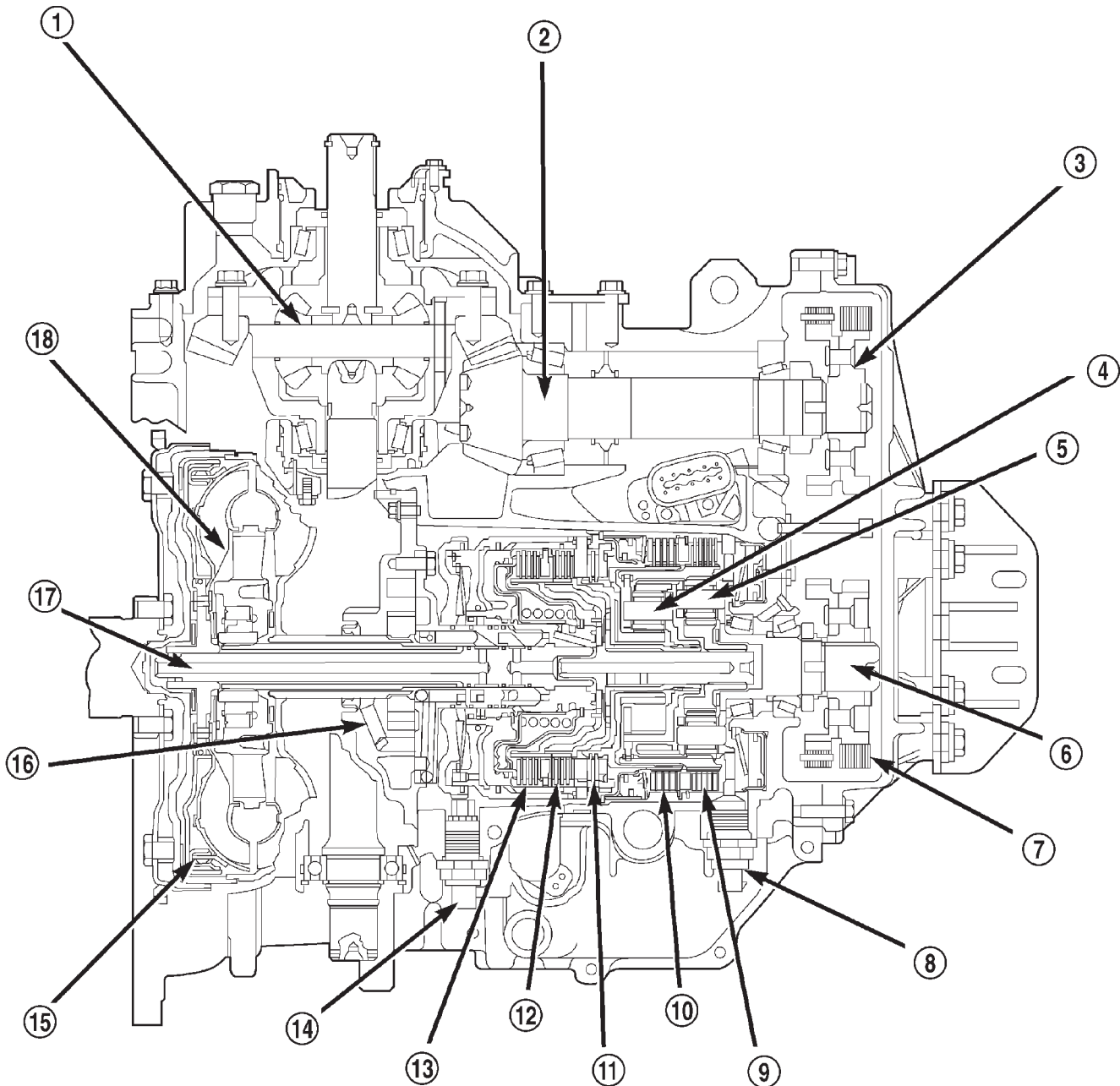

Fig. 1 42LE Transaxle

DESCRIPTION AND OPERATION (Continued)

- 1 – DIFFERENTIAL
- 2 – TRANSFER SHAFT
- 3 – TRANSFER GEAR
- 4 – FRONT PLANETARY CARRIER
- 5 – REAR PLANETARY CARRIER
- 6 – OUTPUT SHAFT
- 7 – OUTPUT GEAR
- 8 – OUTPUT SPEED SENSOR
- 9 – LOW/REVERSE CLUTCH
- 10 – 2/4 CLUTCH
- 11 – REVERSE CLUTCH
- 12 – OVERDRIVE CLUTCH
- 13 – UNDERDRIVE CLUTCH
- 14 – INPUT SPEED SENSOR
- 15 – CONVERTER CLUTCH
- 16 – OIL PUMP
- 17 – INPUT SHAFT
- 18 – TORQUE CONVERTER

The 42LE (Fig. 1) is a four-speed transaxle that is a conventional hydraulic/mechanical assembly with an integral differential, and is controlled with adaptive electronic controls and monitors. The hydraulic system of the transaxle consists of the transaxle fluid, fluid passages, hydraulic valves, and various line pressure control components. An input clutch assembly which houses the underdrive, overdrive, and reverse clutches is used. It also utilizes separate holding clutches: 2nd/4th gear and Low/Reverse. The primary mechanical components of the transaxle consist of the following:

- Three multiple disc input clutches
- Two multiple disc holding clutches
- Four hydraulic accumulators
- Two planetary gear sets
- Hydraulic oil pump
- Valve body
- Solenoid/Pressure switch assembly
- Integral differential assembly

Control of the transaxle is accomplished by fully adaptive electronics. Optimum shift scheduling is accomplished through continuous real-time sensor feedback information provided to the Transmission Control Module (TCM).

The TCM is the heart of the electronic control system and relies on information from various direct and indirect inputs (sensors, switches, etc.) to determine driver demand and vehicle operating conditions. With this information, the TCM can calculate and perform timely and quality shifts through various output or control devices (solenoid pack, transmission control relay, etc.).

The TCM also performs certain self-diagnostic functions and provides comprehensive information (sensor data, DTC's, etc.) which is helpful in proper diagnosis and repair. This information can be viewed with the DRB scan tool.

TRANSAXLE IDENTIFICATION

The 42LE transaxle identification code is a series of digits printed on a bar-code label that is fixed to the transaxle case as shown in (Fig. 2).

For example, the identification code K 821 1125 1316 can be broken down as follows:

- K = Kokomo Transmission Plant
- 821 = Last three digits of the transaxle part number
- 1125 = Build date
- 1316 = Build sequence number

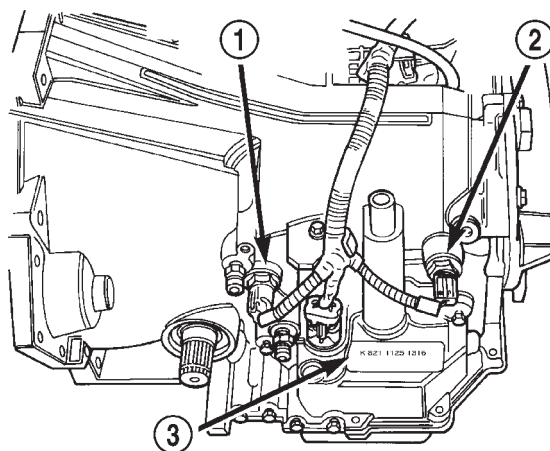

Fig. 2 Transaxle Identification Label

80ad086f

- 1 – INPUT SPEED SENSOR
- 2 – OUTPUT SPEED SENSOR
- 3 – IDENTIFICATION TAG

If the tag is not legible or missing, the “PK” number, which is stamped into the transaxle case, can be referred to for identification. This number differs slightly in that it contains the entire transaxle part number, rather than the last three digits.

OPERATION

Transmission output is directed to an integral differential by a transfer gear system in the following input-to-output ratios:

First	2.84 : 1
Second	1.57 : 1
Third	1.00 : 1
Overdrive	0.69 : 1
Reverse	2.21 : 1

DESCRIPTION AND OPERATION (Continued)

FLUID REQUIREMENT

NOTE: Refer to the maintenance schedules in Group 0, Lubrication and Maintenance for the recommended maintenance (fluid/filter change) intervals for this transaxle.

NOTE: Refer to Service Procedures in this group for fluid level checking procedures.

NOTE: The 42LE transaxle has separate transmission and differential oil sumps, each requiring different fluids.

DESCRIPTION

TRANSMISSION

Mopar® ATF+4 (Automatic Transmission Fluid-Type 9602) is required in this transaxle. Substitute fluids can induce torque converter clutch shudder.

Mopar® ATF+4 (Automatic Transmission Fluid-Type 9602) when new is red in color. The ATF is dyed red so it can be identified from other fluids used in the vehicle such as engine oil or antifreeze. The red color is not permanent and is not an indicator of fluid condition. As the vehicle is driven, the ATF will begin to look darker in color and may eventually become brown. **This is normal.** A dark brown/black fluid accompanied with a burnt odor and/or deterioration in shift quality may indicate fluid deterioration or transmission component failure.

DIFFERENTIAL

The differential sump should be filled with Mopar® 75W-90 hypoid gear lubricant. Synthetic gear lubricants should be avoided.

FLUID ADDITIVES

DaimlerChrysler strongly recommends against the addition of any fluids to the transmission, other than those automatic transmission fluids listed above. Exceptions to this policy are the use of special dyes to aid in detecting fluid leaks.

Various "special" additives and supplements exist that claim to improve shift feel and/or quality. These additives and others also claim to improve converter clutch operation and inhibit overheating, oxidation, varnish, and sludge. These claims have not been supported to the satisfaction of DaimlerChrysler and these additives **must not be used.** The use of transmission "sealers" should also be avoided, since they may adversely affect the integrity of transmission seals.

TORQUE CONVERTER

DESCRIPTION

The torque converter is located in the bellhousing area of the transaxle, between the engine and transaxle. The torque converter is a fluid coupling that transmits torque from the engine drive plate to the input shaft of the transaxle. The torque converter consists of four main components (Fig. 3) :

- Impeller
- Turbine
- Stator
- Converter Clutch assembly

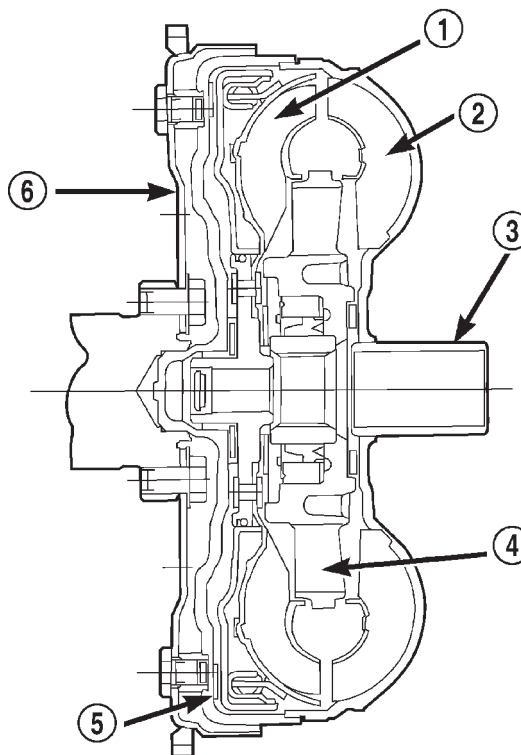

80be46a3

Fig. 3 Torque Converter Assembly

- 1 - TURBINE
- 2 - IMPELLER
- 3 - HUB
- 4 - STATOR
- 5 - CONVERTER CLUTCH DISC
- 6 - DRIVE PLATE

OPERATION

The converter impeller (driving member), which is integral to the converter housing and bolted to the engine drive plate, rotates at engine speed. The converter turbine (driven member), which reacts from fluid pressure generated by the impeller, rotates and turns the transmission input shaft.

Torque is transmitted by fluid passing through curved vanes in both the impeller and turbine. Since

DESCRIPTION AND OPERATION (Continued)

the coupling is produced by transmission fluid, the turbine can slip or turn slower than the impeller.

The stator contains a one-way overrunning clutch, which free-wheels when the impeller and turbine are rotating at the same speed. However, the stator stops when speed reduction or torque increase take place. When the stator stops, it changes the direction of the fluid leaving the turbine vanes. This directs fluid back into the impeller with greater force, resulting in torque multiplication.

The torque converter clutch is hydraulically operated and controlled by the TCM. It consists of a piston and a frictional disc that form a direct mechanical link between the impeller and turbine when slippage is inefficient or unnecessary.

The torque converter hub drives the transmission oil pump.

ELECTRONICALLY MODULATED CONVERTER CLUTCH

In order to reduce heat build-up in the transmission and buffer the powertrain against torsional vibrations, the TCM can duty cycle the LR/CC solenoid to achieve a smooth application of the torque converter clutch. This function, also referred as "Electronically Modulated Converter Clutch (EMCC), can occur at various times depending on the following variables:

- Shift lever position
- Current gear range
- Transmission fluid temperature
- Engine coolant temperature
- Input speed
- Throttle angle
- Engine speed

The TCM controls the torque converter by way of internal logic software. The programming of the software provides the TCM with fine control over the LR/CC solenoid. There are four output logic states that can be applied as follows:

- No EMCC
- Partial EMCC
- Full EMCC
- Gradual-to-no EMCC

NO EMCC

Under No EMCC conditions, the L/R Solenoid is OFF. There are several conditions that can result in NO EMCC operations. No EMCC can be initiated due to a fault in the transaxle or because the TCM does not see the need for EMCC under current driving conditions.

PARTIAL EMCC

Partial EMCC operation modulates the L/R Solenoid (duty cycle) to obtain partial torque converter

clutch application. Partial EMCC operation is maintained until Full EMCC is called for an actuated. During Partial EMCC some slip does occur. Partial EMCC will usually occur at low speeds, low load and light throttle situations.

FULL EMCC

During Full EMCC operation, the TCM increases the L/R Solenoid duty cycle to full ON after Partial EMCC control brings the engine speed within the desired slip range of transaxle input speed relative to engine rpm.

GRADUAL-TO-NO EMCC

This operation is to soften the change from Full or Partial EMCC to No EMCC. This is done at mid-throttle by decreasing the L/R Solenoid duty cycle.

OIL PUMP

DESCRIPTION

The oil pump is located in the pump housing inside the bell housing of the transaxle case. The oil pump consists of an inner and outer gear, a housing, and a cover that also serves as the reaction shaft support.

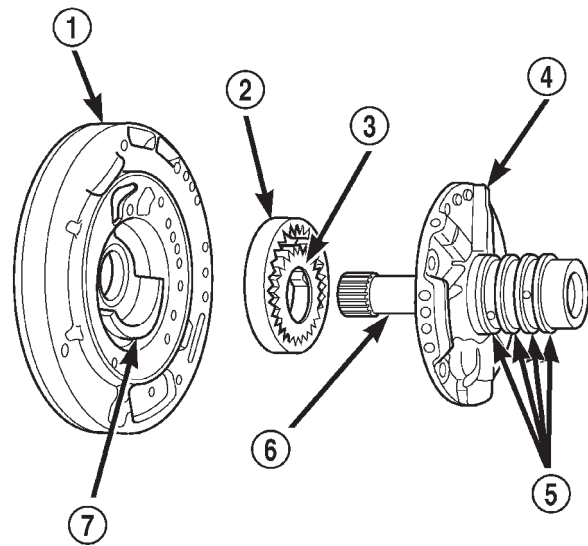

80be46c4

Fig. 4 Oil Pump Assembly

- 1 - PUMP HOUSING
- 2 - OUTER PUMP GEAR
- 3 - INNER PUMP GEAR
- 4 - REACTION SHAFT SUPPORT
- 5 - SEAL RINGS (4)
- 6 - REACTION SHAFT
- 7 - CRESCENT

DESCRIPTION AND OPERATION (Continued)

OPERATION

As the torque converter rotates, the converter hub rotates the inner and outer gears. As the gears rotate, the clearance between the gear teeth increases in the crescent area, and creates a suction at the inlet side of the pump. This suction draws fluid through the pump inlet from the oil pan. As the clearance between the gear teeth in the crescent area decreases, it forces pressurized fluid into the pump outlet and to the valve body.

VALVE BODY

DESCRIPTION

The valve body assembly (Fig. 5) consists of a cast aluminum valve body, a separator plate, and transfer plate. The valve body contains valves and check balls that control fluid delivery to the torque converter clutch, solenoid/pressure switch assembly, and frictional clutches.

Also mounted to the valve body assembly are the solenoid/pressure switch assembly and the transmission range sensor (Fig. 5).

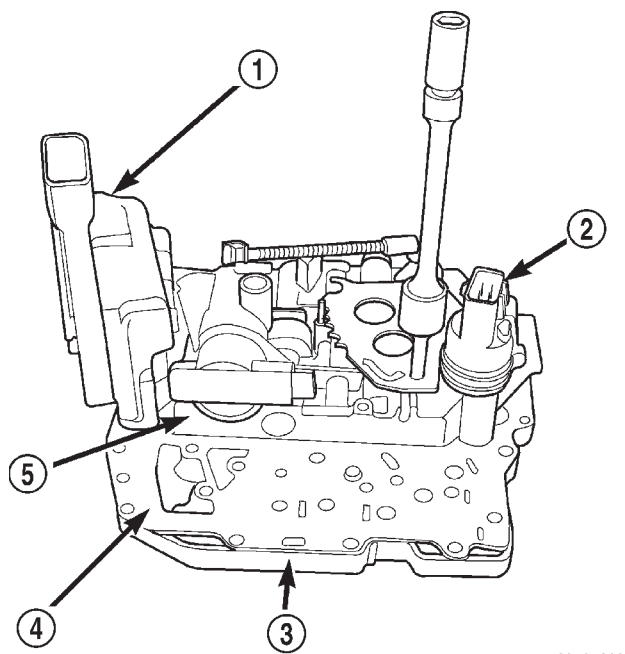

80c07300

Fig. 5 Valve Body Assembly

- 1 - SOLENOID/PRESSURE SWITCH ASSEMBLY
- 2 - TRS
- 3 - TRANSFER PLATE
- 4 - SEPARATOR PLATE
- 5 - VALVE BODY

The valves contained within the valve body include the following (Fig. 6):

- Regulator valve
- Solenoid switch valve

- Manual valve
- Converter clutch switch valve
- Converter clutch control valve
- Torque converter regulator valve
- Low/Reverse switch valve
- Vent reservoir check valve

In addition, the valve body also contains the thermal valve, #2,3,4 & 5 check balls and the 2/4 accumulator assembly. Refer to Valve Body Disassembly & Assembly for the location of these components.

OPERATION

NOTE: Refer to the Hydraulic Schematics for a visual aid in determining valve location, operation and design.

REGULATOR VALVE

The regulator valve controls hydraulic pressure in the transaxle. It receives unregulated pressure from the pump, which works against spring tension to maintain oil at specific pressures. A system of sleeves and ports allows the regulator valve to work at one of three predetermined pressure levels. Regulated oil pressure is also referred to as "line pressure."

SOLENOID SWITCH VALVE

The solenoid switch valve controls line pressure from the LR/CC solenoid. In one position, it allows the low/reverse clutch to be pressurized. In the other, it directs line pressure to the converter control and converter clutch valves.

MANUAL VALVE

The manual valve is operated by the mechanical shift linkage. Its primary responsibility is to send line pressure to the appropriate hydraulic circuits and solenoids. The valve has three operating ranges or positions.

CONVERTER CLUTCH SWITCH VALVE

The main responsibility of the converter clutch switch valve is to control hydraulic pressure applied to the front (off) side of the converter clutch piston. Line pressure from the regulator valve is fed to the torque converter regulator valve, where it passes through the valve, and is slightly regulated. The pressure is then directed to the converter clutch switch valve and to the front side of the converter clutch piston. This pressure pushes the piston back and disengages the converter clutch.

CONVERTER CLUTCH CONTROL VALVE

The converter clutch control valve controls the back (on) side of the torque converter clutch. When the TCM energizes or modulates the LR/CC solenoid

DESCRIPTION AND OPERATION (Continued)

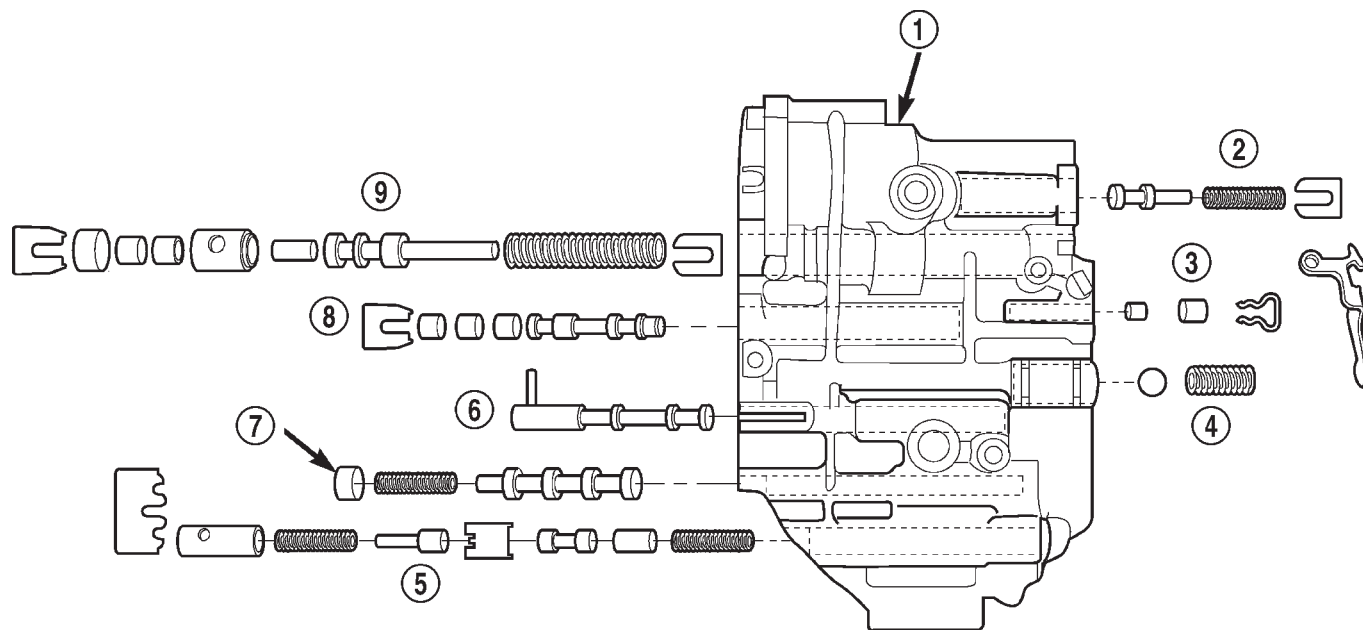

80bdb80

Fig. 6 Valve Body—Exploded

- | | |
|------------------------------------|-----------------------------------|
| 1 - VALVE BODY | 6 - MANUAL VALVE |
| 2 - T/C REGULATOR VALVE | 7 - CONVERTER CLUTCH SWITCH VALVE |
| 3 - L/R SWITCH VALVE | 8 - SOLENOID SWITCH VALVE |
| 4 - VENT RESERVOIR CHECK VALVE | 9 - REGULATOR VALVE |
| 5 - CONVERTER CLUTCH CONTROL VALVE | |

to apply the converter clutch piston, both the converter clutch control valve and the converter control valve move, allowing pressure to be applied to the back side of the clutch.

T/C REGULATOR VALVE

The torque converter regulator valve slightly regulates the flow of fluid to the torque converter.

LOW/REVERSE SWITCH VALVE

The low/reverse clutch is applied from different sources, depending on whether low (1st) gear or reverse is selected. The low/reverse switch valve alternates positions depending on from which direction fluid pressure is applied. By design, when the valve is shifted by fluid pressure from one channel, the opposing channel is blocked. The switch valve alienates the possibility of a sticking ball check, thus providing consistent application of the low/reverse clutch under all operating conditions.

VENT RESERVOIR CHECK VALVE

The vent reservoir check valve is designed for quick venting during garage shifts to prevent the overdrive and reverse clutches from dragging. Inad-

vertent motion of the reverse/overdrive (push/pull) piston can be caused by the unbalanced centrifugal forces in the reverse and overdrive chambers. By linking the overdrive and reverse vents to the vent reservoir at the manual valve, an equal residual pressure will be maintained, thus balancing the centrifugal forces in the reverse and the overdrive chambers.

ACCUMULATORS

DESCRIPTION

The 42LE underdrive, overdrive, low/reverse, and 2/4 clutch hydraulic circuits each contain an accumulator. An accumulator assembly typically consists of a piston, seals, return spring(s), and a cover or plug (Fig. 7).

The overdrive and underdrive accumulators are located within the transaxle case, and are retained by the valve body (Fig. 8).

The low reverse accumulator (Fig. 8) is also located within the transaxle case, but the assembly is retained by a cover and a snap-ring.

DESCRIPTION AND OPERATION (Continued)

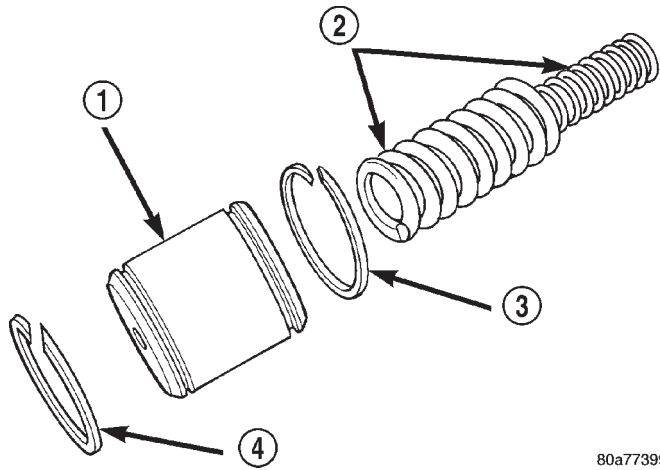

80a77399

Fig. 7 Accumulator Assembly—Typical

- 1 - ACCUMULATOR PISTON (UNDERDRIVE)
- 2 - RETURN SPRINGS
- 3 - SEAL RING
- 4 - SEAL RING

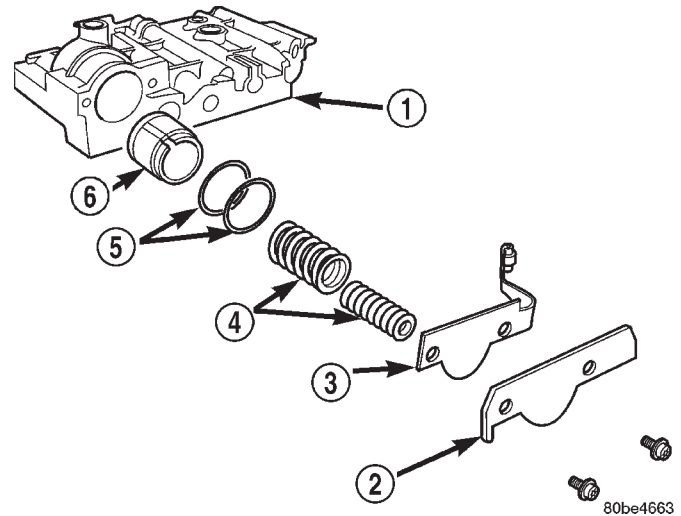

80be4663

Fig. 9 2/4 Accumulator Assembly

- 1 - VALVE BODY
- 2 - RETAINER PLATE
- 3 - DETENT SPRING
- 4 - SPRINGS
- 5 - SEALS
- 6 - PISTON

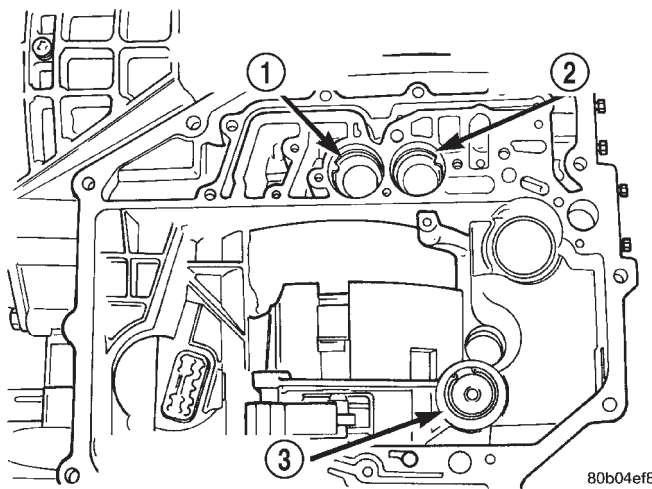

80b04ef8

Fig. 8 Overdrive, Underdrive and Low/Reverse Accumulator Location

- 1 - OVERDRIVE ACCUMULATOR LOCATION
- 2 - UNDERDRIVE ACCUMULATOR LOCATION
- 3 - LOW/REVERSE ACCUMULATOR

(1) The 2/4 accumulator is located in the valve body. It is retained by a cover and retaining screws (Fig. 9).

OPERATION

The function of an accumulator is to cushion the application of a frictional clutch element. When pressurized fluid is applied to a clutch circuit, the application force is dampened by fluid collecting in the respective accumulator chamber against the piston and spring(s). The intended result is a smooth, firm clutch application.

INPUT CLUTCHES

DESCRIPTION

Three hydraulically applied input clutches are used to drive planetary components. The underdrive, overdrive, and reverse clutches are considered input clutches and are contained within the input clutch assembly (Fig. 10). The input clutch assembly also contains:

- Input shaft
- Input hub
- Clutch retainer
- Underdrive piston
- Overdrive/reverse piston
- Overdrive hub
- Underdrive hub

OPERATION

The three input clutches are responsible for driving different components of the planetary geartrain.

NOTE: Refer to the “Elements In Use” chart in Diagnosis and Testing for a collective view of which clutch elements are applied at each position of the selector lever.

UNDERDRIVE CLUTCH

The underdrive clutch is hydraulically applied in first, second, and third (direct) gears by pressurized fluid against the underdrive piston. When the under-

DESCRIPTION AND OPERATION (Continued)

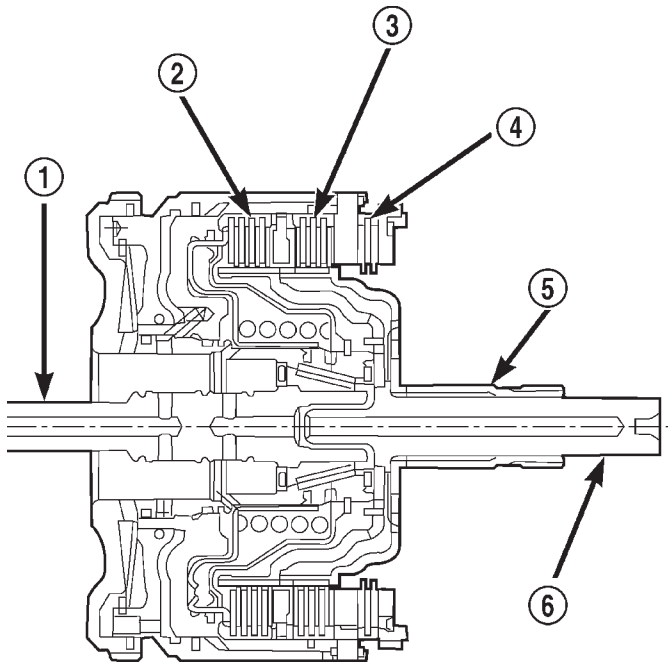

80be46a4

Fig. 10 Input Clutch Assembly

- 1 - INPUT SHAFT
- 2 - UNDERDRIVE CLUTCH
- 3 - OVERDRIVE CLUTCH
- 4 - REVERSE CLUTCH
- 5 - OVERDRIVE SHAFT
- 6 - UNDERDRIVE SHAFT

drive clutch is applied, the underdrive hub drives the rear sun gear.

OVERDRIVE CLUTCH

The overdrive clutch is hydraulically applied in third (direct) and overdrive gears by pressurized fluid against the overdrive/reverse piston. When the overdrive clutch is applied, the overdrive hub drives the front planet carrier.

REVERSE CLUTCH

The reverse clutch is hydraulically applied in reverse gear only by pressurized fluid against the overdrive/reverse piston. When the reverse clutch is applied, the front sun gear assembly is driven.

HOLDING CLUTCHES

DESCRIPTION

Two hydraulically applied multi-disc clutches are used to hold planetary geartrain components stationary while the input clutches drive others. The 2/4 and Low/Reverse clutches are considered holding

clutches and are contained at the rear of the transaxle case. (Fig. 11).

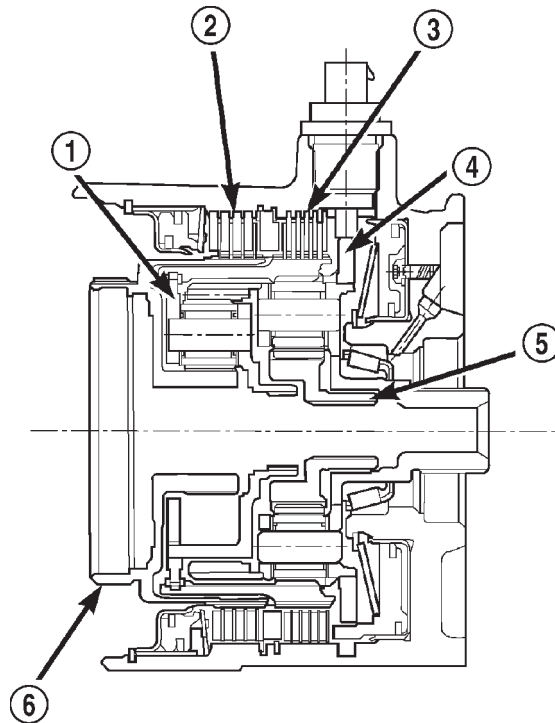

80be46c5

Fig. 11 2/4 and Low/Reverse Clutches

- 1 - FRONT PLANET CARRIER/REAR ANNULUS
- 2 - 2/4 CLUTCH
- 3 - L/R CLUTCH
- 4 - REAR PLANET CARRIER/FRONT ANNULUS
- 5 - REAR SUN GEAR
- 6 - FRONT SUN GEAR ASSEMBLY

OPERATION

NOTE: Refer to the "Elements In Use" chart in **Diagnosis and Testing** for a collective view of which clutch elements are applied at each position of the selector lever.

2/4 CLUTCH

The 2/4 clutch is hydraulically applied in second and fourth gears by pressurized fluid against the 2/4 clutch piston. When the 2/4 clutch is applied, the front sun gear assembly is held or grounded to the transaxle case.

LOW/REVERSE CLUTCH

The Low/Reverse clutch is hydraulically applied in park, reverse, neutral, and first gears by pressurized fluid against the Low/Reverse clutch piston. When the Low/Reverse clutch is applied, the front planet

DESCRIPTION AND OPERATION (Continued)

carrier/rear annulus assembly is held or grounded to the transaxle case.

PLANETARY GEARTRAIN

DESCRIPTION

The planetary geartrain is located between the input clutch assembly and the rear of the transaxle case. The planetary geartrain consists of two sun gears, two planetary carriers, two annulus (ring) gears, and one output shaft (Fig. 12).

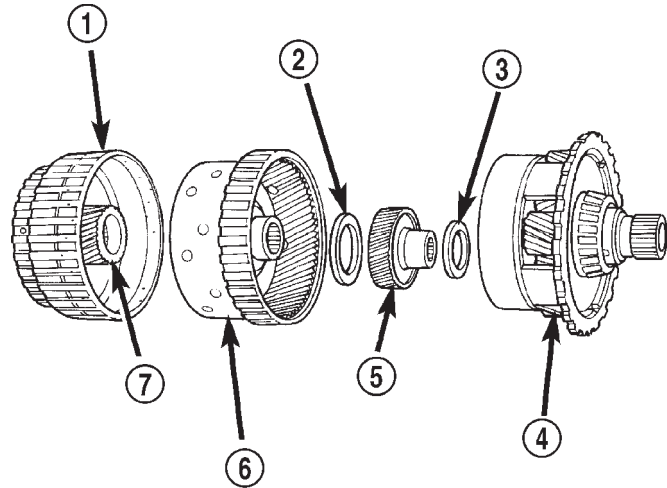

Fig. 12 Planetary Geartrain

- 1 - FRONT SUN GEAR ASSEMBLY
- 2 - #6 THRUST BEARING
- 3 - #7 THRUST BEARING
- 4 - REAR CARRIER FRONT ANNULUS ASSEMBLY
- 5 - REAR SUN GEAR
- 6 - FRONT CARRIER REAR ANNULUS ASSEMBLY
- 7 - FRONT SUN GEAR

80be46c9

OPERATION

The planetary geartrain utilizes two planetary gear sets that connect the transmission input shaft to the output shaft. Input and holding clutches drive or lock different planetary members to change output ratio or direction.

DIFFERENTIAL

DESCRIPTION

The 42LE differential is a conventional open design. It consists of a hypoid type ring and pinion set, and a differential case. The differential case consists of pinion and side gears, and a pinion shaft. The differential case is supported in the transaxle by tapered roller bearings (Fig. 13).

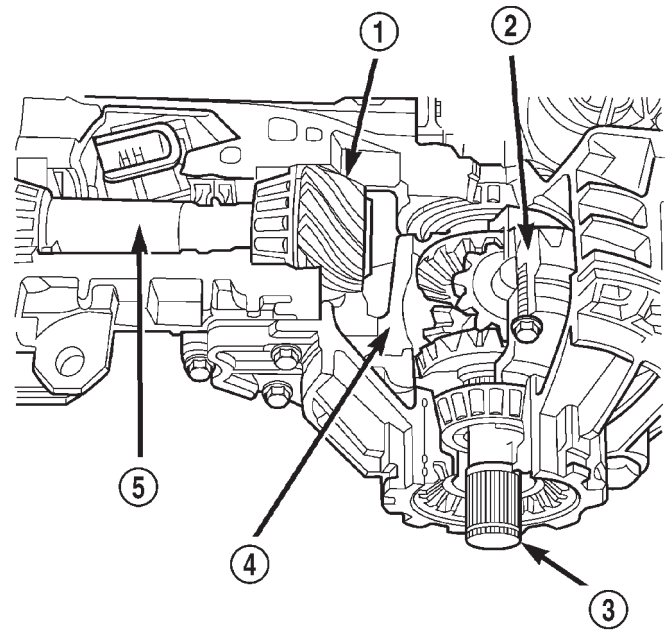

80c07210

Fig. 13 Differential Assembly

- 1 - PINION GEAR
- 2 - RING GEAR
- 3 - SHORT STUB SHAFT
- 4 - DIFFERENTIAL CASE ASSEMBLY
- 5 - TRANSFER SHAFT

OPERATION

The differential assembly is driven by the transfer shaft by way of the differential ring gear. The ring gear drives the differential case, and the case drives the driveshafts through the differential gears. The differential pinion and side gears are supported in the case by thrust washers and a pinion shaft. Differential pinion and side gears make it possible for front tires to rotate at different speeds while cornering.

TRANSMISSION CONTROL MODULE

DESCRIPTION

The Transmission Control Module (TCM) is located in the engine compartment on the left (driver's) side next to the Power Distribution Center (PDC) (Fig. 14).

OPERATION

The TCM is the controlling unit for all electronic operations of the transaxle. The TCM receives information regarding vehicle operation from both direct and indirect inputs, and selects the operational mode of the transaxle. Direct inputs are hard-wired to, and used specifically by the TCM. Indirect inputs origi-

DESCRIPTION AND OPERATION (Continued)

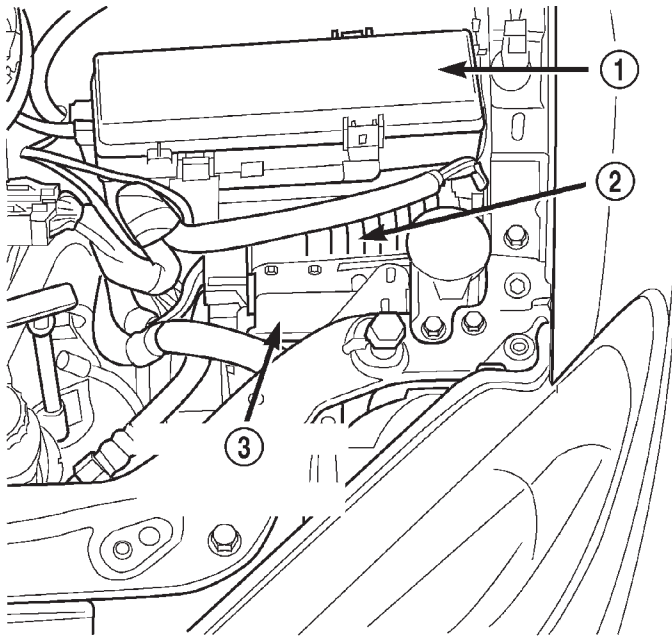

80b3b0a6

Fig. 14 Transmission Control Module Location (Typical)

- 1 - PDC
- 2 - PCM
- 3 - TRANSMISSION CONTROL MODULE (TCM)

nate from other components/modules, and are shared with the TCM via the PCI bus.

Some examples of **direct inputs** to the TCM are:

- Battery (B+) voltage
- Ignition "ON" voltage
- Transmission Control Relay (Switched B+)
- Throttle Position Sensor
- Crankshaft Position Sensor (CKP)
- Transmission Range Sensor (TRS)
- Pressure Switches (L/R, 2/4, OD)
- Transmission Temperature Sensor (Integral to TRS)

- Input Shaft Speed Sensor
- Output Shaft Speed Sensor
- TRS Hall Effect Switch (Autostick)

Some examples of **indirect inputs** to the TCM are:

- Engine/Body Identification
- Manifold Pressure
- Target Idle
- Torque Reduction Confirmation
- Speed Control ON/OFF Switch
- Engine Coolant Temperature
- Ambient/Battery Temperature
- Brake Switch Status
- DRB Communication

Based on the information received from these various inputs, the TCM determines the appropriate shift schedule and shift points, depending on the present operating conditions and driver demand. This is possible through the control of various direct and indirect outputs.

Some examples of TCM **direct outputs** are:

- Transmission Control Relay
- Solenoids (L/R, 2/4, OD and UD)
- Vehicle Speed (to PCM)
- Torque Reduction Request (to PCM)

Some examples of TCM **indirect outputs** are:

- Transmission Temperature (to PCM)
- PRNDL Position (to BCM)
- Autostick Display (to BCM)

In addition to monitoring inputs and controlling outputs, the TCM has other important responsibilities and functions:

- Storing and maintaining Clutch Volume Indices (CVI)
- Storing and selecting appropriate Shift Schedules
- System self-diagnostics
- Diagnostic capabilities (with DRB III scan tool)

NOTE: If the TCM has been replaced, the "Quick Learn Procedure" must be performed. Refer to "Quick Learn Procedure" in Service Procedures of this group.

CLUTCH VOLUME INDEX (CVI)

An important function of the TCM is to monitor Clutch Volume Index (CVI). CVIs represent the volume of fluid needed to compress a clutch pack.

The TCM monitors gear ratio changes by monitoring the Input and Output Speed Sensors. The Input, or Turbine Speed Sensor sends an electrical signal to the TCM that represents input shaft rpm. The Output Speed Sensor provides the TCM with output shaft speed information.

By comparing the two inputs, the TCM can determine transaxle gear position. This is important to the CVI calculation because the TCM determines CVIs by monitoring how long it takes for a gear change to occur (Fig. 15).

Gear ratios can be determined by using the DRB Scan Tool and reading the Input/Output Speed Sensor values in the "Monitors" display. Gear ratio can be obtained by dividing the Input Speed Sensor value by the Output Speed Sensor value.

For example, if the input shaft is rotating at 1000 rpm and the output shaft is rotating at 500 rpm, then the TCM can determine that the gear ratio is

DESCRIPTION AND OPERATION (Continued)

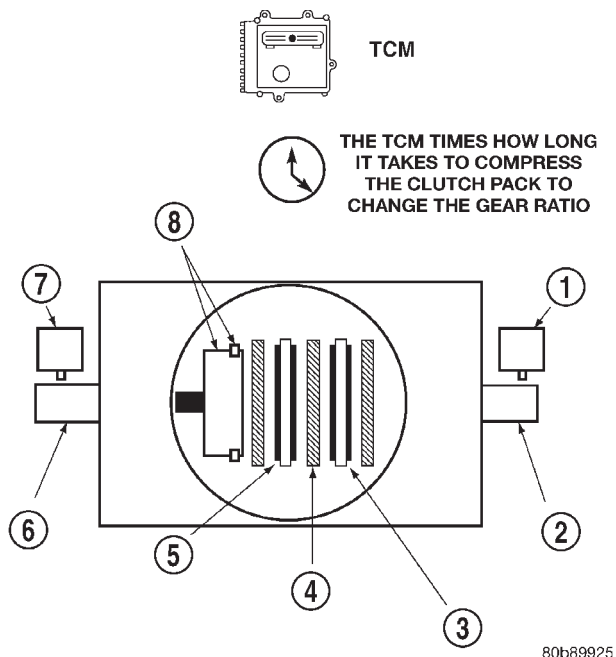

80b89925

Fig. 15 Example of CVI Calculation

- 1 – OUTPUT SPEED SENSOR
- 2 – OUTPUT SHAFT
- 3 – CLUTCH PACK
- 4 – SEPARATOR PLATE
- 5 – FRICTION DISCS
- 6 – INPUT SHAFT
- 7 – INPUT SPEED SENSOR
- 8 – PISTON AND SEAL

2:1. In direct drive (3rd gear), the gear ratio changes to 1:1. The gear ratio changes as clutches are applied and released. By monitoring the length of time it takes for the gear ratio to change following a shift request, the TCM can determine the volume of fluid used to apply or release a friction element.

The volume of transmission fluid needed to apply the friction elements are continuously updated for adaptive controls. As friction material wears, the volume of fluid need to apply the element increases.

Certain mechanical problems within the input clutch assembly (broken return springs, out of position snap rings, excessive clutch pack clearance, improper assembly, etc.) can cause inadequate or out-of-range element volumes. Also, defective Input/Output Speed Sensors and wiring can cause these conditions. The following chart identifies the appropriate clutch volumes and when they are monitored/updated:

CLUTCH VOLUMES				
Clutch	When Updated			Proper Clutch Volume
	Shift Sequence	Oil Temperature	Throttle Angle	
L/R	2-1 or 3-1 coast downshift	> 70°	< 5°	35 to 83
2/4	1-2 shift	> 110°	5 - 54°	20 to 77
OD	2-3 shift			48 to 150
UD	4-3 or 4-2 shift		> 5°	24 to 70

SHIFT SCHEDULES

As mentioned earlier, the TCM has programming that allows it to select a variety of shift schedules. Shift schedule selection is dependent on the following:

- Shift lever position
- Throttle position

- Engine load
- Fluid temperature
- Software level

As driving conditions change, the TCM appropriately adjusts the shift schedule. Refer to the following chart to determine the appropriate operation expected, depending on driving conditions.

DESCRIPTION AND OPERATION (Continued)

Schedule	Condition	Expected Operation
Extreme Cold	Oil temperature at start-up below -16° F	Park, Reverse, Neutral and 2nd gear only (prevents shifting which may fail a clutch with frequent shifts)
Cold	Oil temperature at start-up above -12° F and below 36° F	<ul style="list-style-type: none"> – Delayed 2-3 upshift (approximately 22-31 mph) – Delayed 3-4 upshift (45-53 mph) – Early 4-3 coastdown shift (approximately 30 mph) – Early 3-2 coastdown shift (approximately 17 mph) – High speed 4-2, 3-2, 2-1 kickdown shifts are prevented – No EMCC
Warm	Oil temperature at start-up above 36° F and below 80 degree F	<ul style="list-style-type: none"> – Normal operation (upshift, kickdowns, and coastdowns) – No EMCC
Hot	Oil temperature at start-up above 80° F	<ul style="list-style-type: none"> – Normal operation (upshift, kickdowns, and coastdowns) – Full EMCC, no PEMCC except to engage FEMCC (except at closed throttle at speeds above 70-83 mph)
Overheat	Oil temperature above 240° F or engine coolant temperature above 244° F	<ul style="list-style-type: none"> – Delayed 2-3 upshift (25-32 mph) – Delayed 3-4 upshift (41-48 mph) – 3rd gear FEMCC from 30-48 mph – 3rd gear PEMCC from 27-31 mph
Super Overheat	Oil temperature above 260° F	<ul style="list-style-type: none"> – All “Overheat” shift schedule features apply – 2nd gear PEMCC above 22 mph – Above 22 mph the torque converter will not unlock unless the throttle is closed or if a wide open throttle 2nd PEMCC to 1 kickdown is made

TRANSMISSION CONTROL RELAY

DESCRIPTION

The transmission control relay is located in the Power Distribution Center (PDC) on the left side of the engine compartment (Fig. 16).

OPERATION

The relay is supplied fused B+ voltage, energized by the TCM, and is used to supply power to the solenoid pack when the transmission is in normal operating mode. When the relay is “off”, no power is supplied to the solenoid pack and the transmission is

in “limp-in” mode. After a controller reset (ignition key turned to the “run” position or after cranking engine), the TCM energizes the relay. Prior to this, the TCM verifies that the contacts are open by checking for no voltage at the switched battery terminals. After this is verified, the voltage at the solenoid pack pressure switches is checked. After the relay is energized, the TCM monitors the terminals to verify that the voltage is greater than 3 volts.

DESCRIPTION AND OPERATION (Continued)

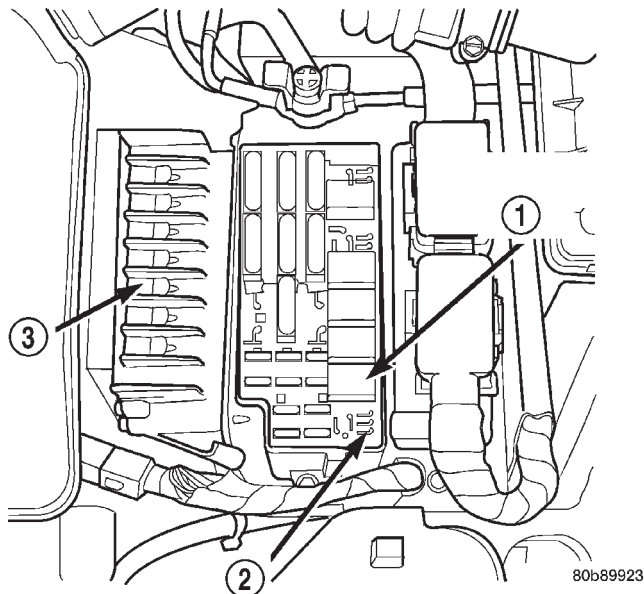

Fig. 16 Transmission Control Relay Location (Typical)

- 1 - TRANSMISSION CONTROL RELAY
- 2 - PDC
- 3 - TCM

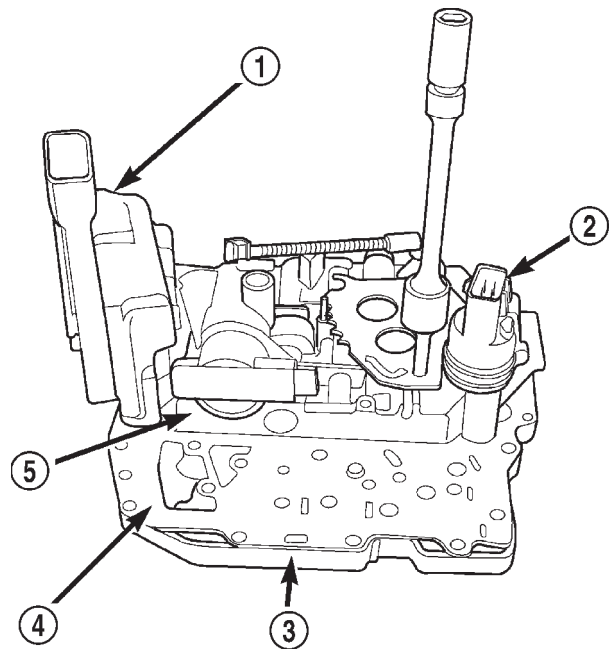

Fig. 17 Solenoid/Pressure Switch Assembly

- 1 - SOLENOID/PRESSURE SWITCH
- 2 - TRS
- 3 - TRANSFER PLATE
- 4 - SEPARATOR PLATE
- 5 - VALVE BODY

SOLENOID/PRESSURE SWITCH ASSEMBLY

DESCRIPTION

The Solenoid/Pressure Switch Assembly (Fig. 17) is inside the transaxle and mounted to the valve body assembly. The assembly consists of four solenoids that control hydraulic pressure to the L/R, 2/4, OD, and UD friction elements (transaxle clutches), and the torque converter clutch. The reverse clutch is controlled by line pressure from the manual valve in the valve body. The solenoids are contained within the Solenoid/Pressure Switch Assembly, and can only be serviced by replacing the assembly.

The solenoid assembly also contains pressure switches that monitor and send hydraulic circuit information to the TCM. Likewise, the pressure switches can only be service by replacing the assembly.

OPERATION

SOLENOIDS

The solenoids receive electrical power from the Transmission Control Relay through a single wire. The TCM energizes or operates the solenoids individually by grounding the return wire of the solenoid needed. When a solenoid is energized, the solenoid valve shifts, and a fluid passage is opened or closed (vented or applied), depending on its default operating state. The result is an apply or release of a frictional element.

The 2/4 and UD solenoids are normally applied, which allows fluid to pass through in their relaxed or "off" state. By design, this allows transaxle limp-in (P,R,N,2) in the event of an electrical failure.

The continuity of the solenoids and circuits are periodically tested. Each solenoid is turned on or off depending on its current state. An inductive spike should be detected by the TCM during this test. If no spike is detected, the circuit is tested again to verify the failure. In addition to the periodic testing, the solenoid circuits are tested if a speed ratio or pressure switch error occurs.

PRESSURE SWITCHES

The TCM relies on three pressure switches to monitor fluid pressure in the L/R, 2/4, and OD hydraulic circuits. The primary purpose of these switches is to help the TCM detect when clutch circuit hydraulic failures occur. The range for the pressure switch closing and opening points is 11-23 psi. Typically the switch opening point will be approximately one psi lower than the closing point. For example, a switch may close at 18 psi and open at 17 psi. The switches are continuously monitored by the TCM for the correct states (open or closed) in each gear as shown in the following chart:

A Diagnostic Trouble Code (DTC) will set if the TCM senses any switch open or closed at the wrong time in a given gear.

DESCRIPTION AND OPERATION (Continued)

PRESSURE SWITCH STATES

GEAR	L/R	2/4	OD
R	OP	OP	OP
P/N	CL	OP	OP
1st	CL	OP	OP
2nd	OP	CL	OP
D	OP	OP	CL
OD	OP	CL	CL

OP = OPEN
CL = CLOSED

The TCM also tests the 2/4 and OD pressure switches when they are normally off (OD and 2/4 are tested in 1st gear, OD in 2nd gear, and 2/4 in 2nd gear). The test simply verifies that they are operational, by looking for a closed state when the corresponding element is applied. Immediately after a shift into 1st, 2nd, or 3rd gear with the engine speed above 1000 rpm, the TCM momentarily turns on element pressure to the 2/4 and/or OD clutch circuits to identify that the appropriate switch has closed. If it doesn't close, it is tested again. If the switch fails to close the second time, the appropriate Diagnostic Trouble Code (DTC) will set.

TRANSMISSION RANGE SENSOR

DESCRIPTION

The Transmission Range Sensor (TRS) is mounted to the top of the valve body inside the transaxle and can only be serviced by removing the valve body. The electrical connector extends through the transaxle case (Fig. 18).

The Transmission Range Sensor (TRS) has four switch contacts that monitor shift lever position and send the information to the TCM.

The TRS also has an integrated temperature sensor (thermistor) that communicates transaxle temperature to the TCM and PCM (Fig. 19).

OPERATION

The Transmission Range Sensor (TRS) (Fig. 18) communicates shift lever position (SLP) to the TCM as a combination of open and closed switches. Each shift lever position has an assigned combination of switch states (open/closed) that the TCM receives from four sense circuits. The TCM interprets this information and determines the appropriate transaxle gear position and shift schedule.

Since there are four switches, there are 16 possible combinations of open and closed switches (codes). Seven of these codes are related to gear position and

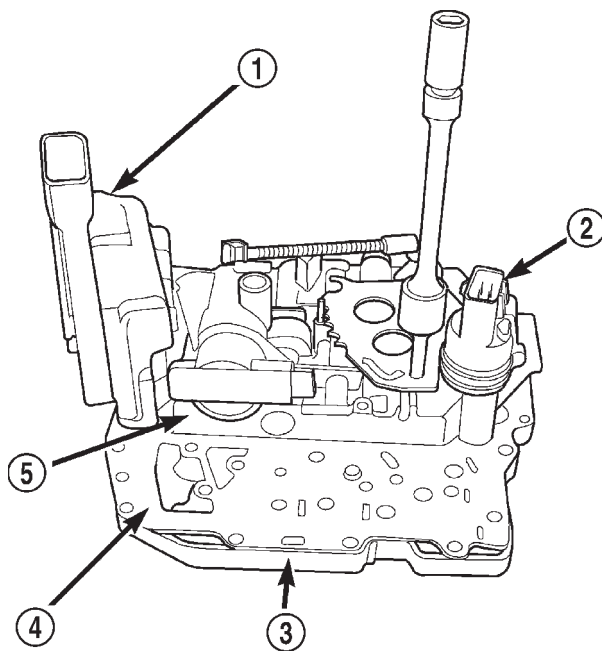

80c07300

Fig. 18 Transmission Range Sensor (TRS) Location

- 1 - SOLENOID/PRESSURE SWITCH ASSEMBLY
- 2 - TRS
- 3 - TRANSFER PLATE
- 4 - SEPARATOR PLATE
- 5 - VALVE BODY

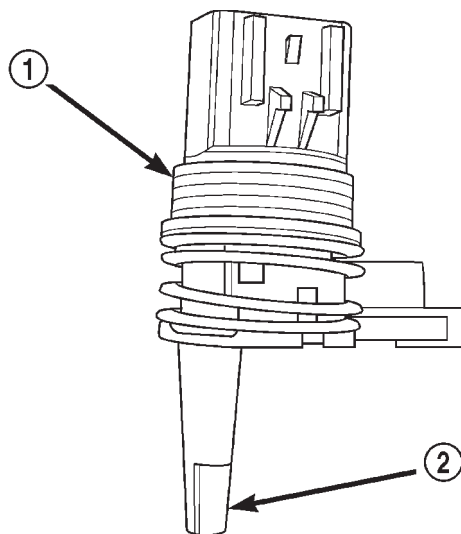

80be46cC

Fig. 19 Transmission Temperature Sensor

- 1 - TRANSMISSION RANGE SENSOR
- 2 - TEMPERATURE SENSOR

three are recognized as "between gear" codes. This results in six codes which should never occur. These are called "invalid" codes. An invalid code will result in a DTC, and the TCM will then determine the shift lever position based on pressure switch data. This

DESCRIPTION AND OPERATION (Continued)

allows reasonably normal transmission operation with a TRS failure.

TRS SWITCH STATES

SLP	T42	T41	T3	T1
P	CL	CL	CL	OP
R	CL	OP	OP	OP
N	CL	CL	OP	CL
OD	OP	OP	OP	CL
3 (AS)	OP	OP	CL	OP
L	CL	OP	CL	CL

TRANSMISSION TEMPERATURE SENSOR

The TRS has an integrated thermistor (Fig. 19) that the TCM uses to monitor the transmission's sump temperature. Since fluid temperature can affect transmission shift quality and convertor lock up, the TCM requires this information to determine which shift schedule to operate in. The PCM also monitors this temperature data so it can energize the vehicle cooling fan(s) when a transmission "overheat" condition exists. If the thermistor circuit fails, the TCM will revert to calculated oil temperature usage.

CALCULATED TEMPERATURE

A failure in the temperature sensor or circuit will result in calculated temperature being substituted for actual temperature. Calculated temperature is a predicted fluid temperature which is calculated from a combination of inputs:

- Battery (ambient) temperature
- Engine coolant temperature
- In-gear run time since start-up

SHIFT POSITION INDICATOR

DESCRIPTION

The shift position indicator is located in the instrument cluster. It indicates the position of the manual valve lever by illuminating an LED located under the P, R, N, D, 3, or L (or Autostick) gear symbol.

OPERATION

The Transmission Range Sensor (TRS) sends a signal to the Transmission Control Module (TCM) regarding the position of the manual valve lever. The TCM converts this signal into a Shift Lever Position (SLP) and sends the information to the BCM (Body Control Module) and the instrument cluster.

Refer to Group 8E, Instrument Panel And Gauges for repair procedures.

INPUT SPEED SENSOR

DESCRIPTION

The Input Speed Sensor is a two-wire magnetic pickup device that generates AC signals as rotation occurs. It is threaded into the transaxle case (Fig. 20), sealed with an o-ring (Fig. 21), and is considered a primary input to the Transmission Control Module (TCM).

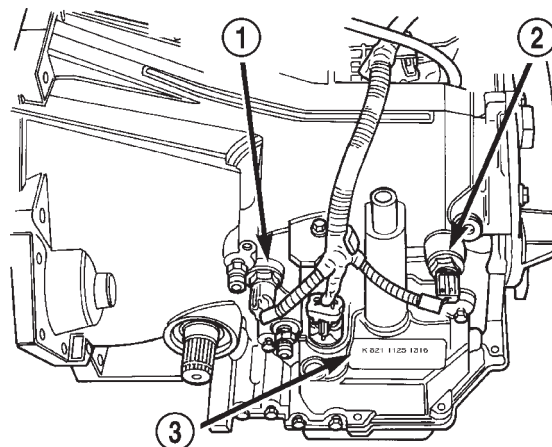

80ad086f

Fig. 20 Input Speed Sensor Location

- 1 - INPUT SPEED SENSOR
- 2 - OUTPUT SPEED SENSOR
- 3 - IDENTIFICATION TAG

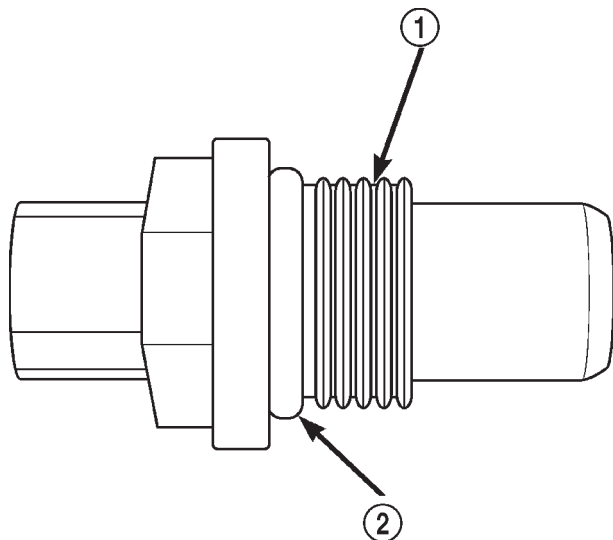

80be46b8

Fig. 21 O-Ring Location

- 1 - INPUT SPEED SENSOR
- 2 - O-RING

DESCRIPTION AND OPERATION (Continued)

OPERATION

The Input Speed Sensor provides information on how fast the input shaft is rotating. As the teeth of the input clutch hub pass by the sensor coil (Fig. 22), an AC voltage is generated and sent to the TCM. The TCM interprets this information as input shaft rpm.

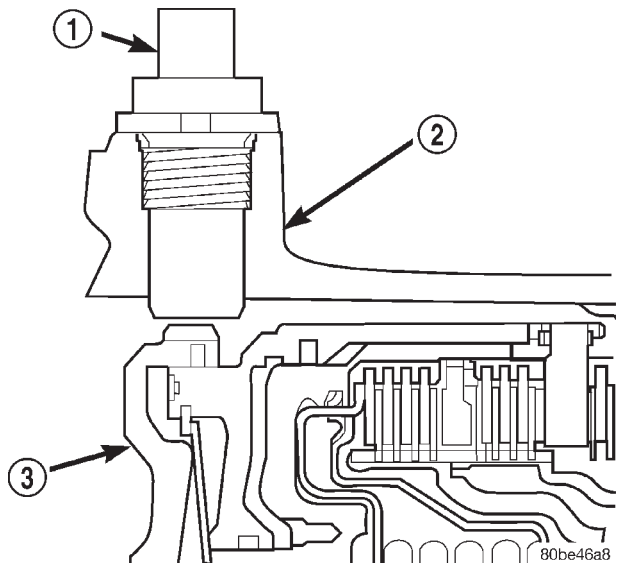

Fig. 22 Sensor Relation to Input Clutch Hub

- 1 - INPUT SPEED SENSOR
- 2 - TRANSAXLE CASE
- 3 - INPUT CLUTCH HUB

The TCM compares the input speed signal with output speed signal to determine the following:

- Transmission gear ratio
- Speed ratio error detection
- CVI calculation

The TCM also compares the input speed signal and the engine speed signal to determine the following:

- Torque converter clutch slippage
- Torque converter element speed ratio

OUTPUT SPEED SENSOR

DESCRIPTION

The Output Speed Sensor is a two-wire magnetic pickup device that generates an AC signal as rotation occurs. It is threaded into the transaxle case (Fig. 23), sealed with an o-ring (Fig. 24), and is considered a primary input to the Transmission Control Module (TCM).

OPERATION

The Output Speed Sensor provides information on how fast the output shaft is rotating. As the rear planetary carrier park pawl lugs pass by the sensor coil (Fig. 25), an AC voltage is generated and sent to the TCM. The TCM interprets this information as output shaft rpm.

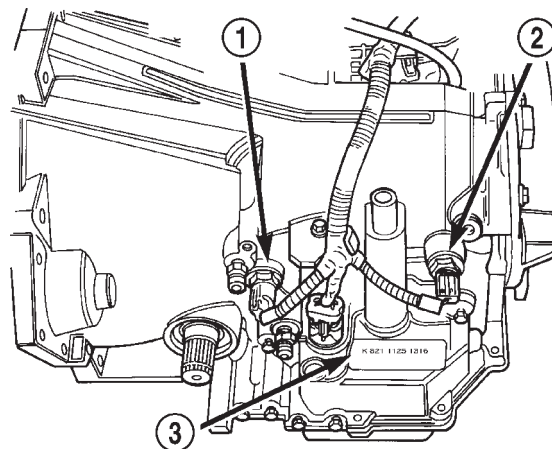

80ad086f

Fig. 23 Output Speed Sensor Location

- 1 - INPUT SPEED SENSOR
- 2 - OUTPUT SPEED SENSOR
- 3 - IDENTIFICATION TAG

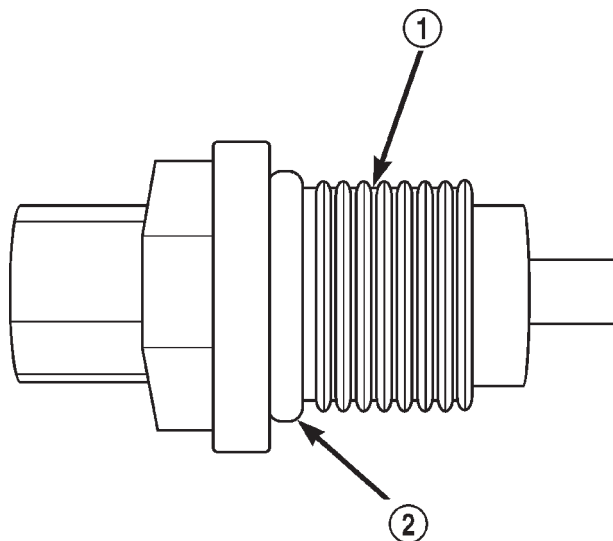

80be46b9

Fig. 24 O-Ring Location

- 1 - OUTPUT SPEED SENSOR
- 2 - O-RING

The TCM compares the input and output speed signals to determine the following:

- Transmission gear ratio
- Speed ratio error detection
- CVI calculation

VEHICLE SPEED SIGNAL

The vehicle speed signal is taken from the Output Speed Sensor. The TCM converts this signal into a pulse per mile signal and sends it to the PCM. The PCM, in turn, sends the vehicle speed message across the PCI Bus to the BCM. The BCM sends this

DESCRIPTION AND OPERATION (Continued)

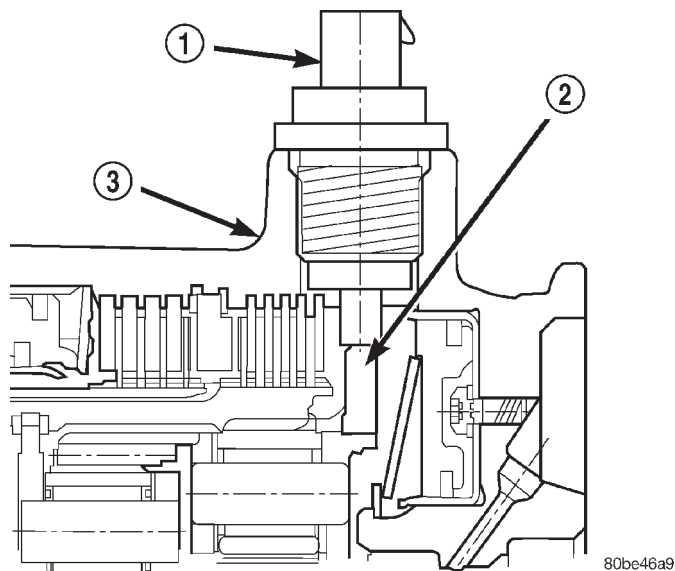

Fig. 25 Sensor Relation to Planet Carrier Park Pawl Lugs

- 1 - OUTPUT SPEED SENSOR
- 2 - REAR PLANET CARRIER/OUTPUT SHAFT ASSEMBLY
- 3 - TRANSAXLE CASE

signal to the Instrument Cluster to display vehicle speed to the driver. The vehicle speed signal pulse is roughly 8000 pulses per mile.

BRAKE TRANSMISSION SHIFT INTERLOCK SYSTEM (FLOOR SHIFT)

DESCRIPTION

The Brake Transmission Shifter/Ignition Interlock (BTISI) is a cable and solenoid operated system that prevents the transmission gear shifter from being moved out of PARK without a driver in place.

Refer to the following chart that expected shifter response, depending on ignition key/switch (Fig. 26) and brake pedal positions.

OPERATION

The Brake Transmission Shifter/Ignition Interlock (BTISI) is engaged whenever the ignition switch is in the LOCK or ACCESSORY position (Fig. 26). An additional electrically activated feature will prevent shifting out of the PARK position unless the brake pedal is depressed at least one-half inch. A magnetic holding device integral to the interlock cable is energized when the ignition is in the ON/RUN position. When the key is in the ON/RUN position and the brake pedal is depressed, the shifter is unlocked and will move into any position. The interlock system also prevents the ignition switch from being turned to the LOCK or ACCESSORY position, unless the shifter is in the gated PARK position.

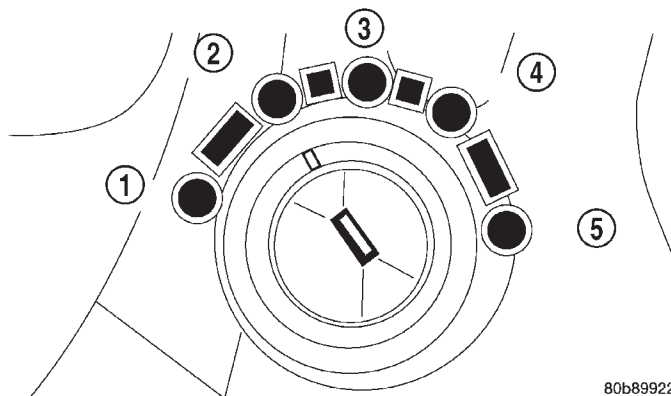

Fig. 26 Ignition Key/Switch Positions

- 1 - ACC
- 2 - LOCK
- 3 - OFF
- 4 - ON/RUN
- 5 - START

The following chart describes the normal operation of the Brake Transmission Shift Interlock (BTISI) system. If the "expected response" differs from the vehicle's response, then system repair and/or adjustment is necessary.

ACTION	EXPECTED RESPONSE
1. Turn key to the "OFF" position.	1. Shifter CAN be shifted out of park.
2. Turn key to the "ON/RUN" position.	2. Shifter CANNOT be shifted out of park.
3. Turn key to the "ON/RUN" position and depress the brake pedal.	3. Shifter CAN be shifted out of park.
4. Leave shifter in any gear and try to return key to the "LOCK" or "ACC" position.	4. Key cannot be returned to the "LOCK" or "ACC" position.
5. Return shifter to "PARK" and try to remove the key.	5. Key can be removed (after returning to "LOCK" position).
6. With the key removed, try to shift out of "PARK".	6. Shifter cannot be shifted out of "PARK".
NOTE: Any failure to meet these expected responses requires system adjustment or repair.	

BRAKE TRANSMISSION SHIFT INTERLOCK SYSTEM (COLUMN SHIFT)

DESCRIPTION

Vehicles equipped with a column shifter utilize a brake transmission shift interlock (BTISI) solenoid, which prevents the transmission gear shifter from

DESCRIPTION AND OPERATION (Continued)

being moved out of PARK without a driver in place (Fig. 27).

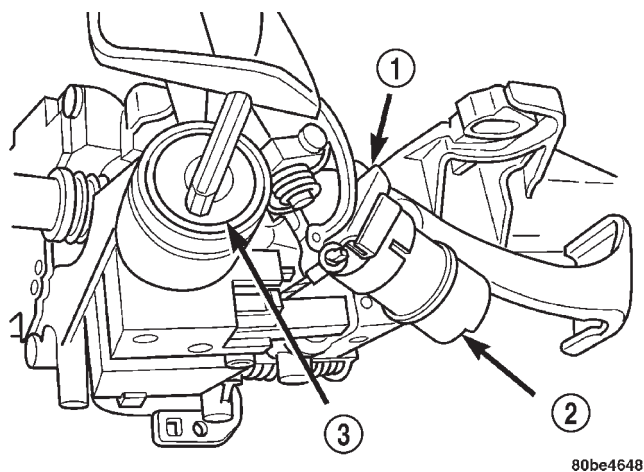

Fig. 27 BTSI Solenoid

- 1 - SHIFT LEVER BRACKET
- 2 - SOLENOID
- 3 - KEY CYLINDER

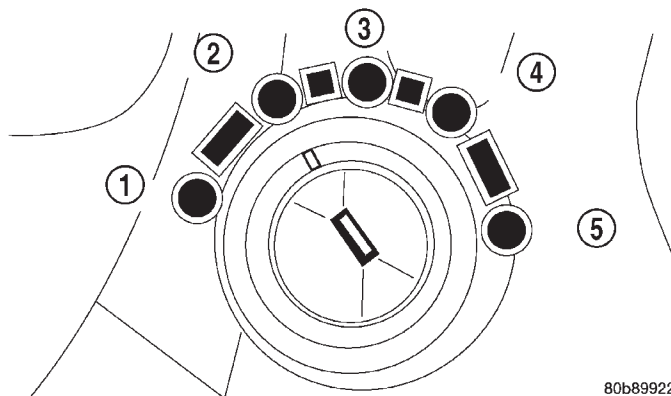

Fig. 28 Ignition Key/Switch Positions

- 1 - ACC
- 2 - LOCK
- 3 - OFF
- 4 - ON/RUN
- 5 - START

OPERATION

The Brake Transmission Shifter/Ignition Interlock (BTSI) is engaged whenever the ignition switch is in the LOCK or ACCESSORY position (Fig. 28). An additional electrically activated feature will prevent shifting out of the PARK position unless the brake pedal is depressed at least one-half inch. A magnetic holding device integral to the interlock cable is energized when the ignition is in the ON/RUN position. When the key is in the ON/RUN position and the brake pedal is depressed, the shifter is unlocked and will move into any position. The interlock system also prevents the ignition switch from being turned to the LOCK or ACCESSORY position, unless the shifter is in the gated PARK position.

The following chart describes the normal operation of the Brake Transmission Shift Interlock (BTSI) system. If the "expected response" differs from the vehicle's response, then system repair and/or adjustment is necessary.

AUTOSTICK

OPERATION

Autostick is a driver-interactive transaxle feature that offers manual gear shifting capability. When the shifter is moved into the Autostick position, the transaxle remains in whatever gear it was using before Autostick was activated. Moving the shifter to the left (towards the driver) causes a downshift and moving to the right (towards the passenger) causes an

ACTION	EXPECTED RESPONSE
1. Turn key to the "OFF" position.	1. Shifter CAN be shifted out of park.
2. Turn key to the "ON/RUN" position.	2. Shifter CANNOT be shifted out of park.
3. Turn key to the "ON/RUN" position and depress the brake pedal.	3. Shifter CAN be shifted out of park.
4. Leave shifter in any gear and try to return key to the "LOCK" or "ACC" position.	4. Key cannot be returned to the "LOCK" or "ACC" position.
5. Return shifter to "PARK" and try to remove the key.	5. Key can be removed (after returning to "LOCK" position).
6. With the key removed, try to shift out of "PARK".	6. Shifter cannot be shifted out of "PARK".
NOTE: Any failure to meet these expected responses requires system adjustment or repair.	

upshift. The instrument cluster will illuminate the selected gear. The vehicle can be launched in 1st, 2nd, or 3rd gear while in the Autostick mode. The speed control is operable in 3rd and 4th gear Autostick mode. Speed control will be deactivated if the transaxle is shifted to 2nd gear. Shifting into OD position cancels the Autostick mode, and the transaxle resumes the OD shift schedule.

AUTOMATIC OVERRIDES

For safety, durability, and driveability, some shifts are executed automatically or prevented.

DESCRIPTION AND OPERATION (Continued)

AUTOMATIC SHIFTS WILL OCCUR UNDER THE FOLLOWING CONDITIONS

TYPE OF SHIFT	APPROXIMATE SHIFT POINT	
	2.7L / 3.2 L	3.5L
4-3 coast downshift	13 mph	13 mph
3-2 coast downshift	9 mph	9 mph
2-1 coast downshift	5 mph	5 mph
1-2 upshift	6300 engine rpm	6600 engine rpm
2-3 upshift	6300 engine rpm	6600 engine rpm
4-3 kickdown shift	13-47 mph w/sufficient throttle	13-47 mph w/sufficient throttle

MANUAL SHIFTS ARE NOT PERMITTED UNDER THE FOLLOWING CONDITIONS

TYPE OF SHIFT	APPROXIMATE SHIFT POINT
3-4 upshift	Below 15 mph
3-2 downshift	Above 74 mph @ closed throttle or 70 mph otherwise
2-1 downshift	Above 41 mph @ closed throttle or 38 mph otherwise

DIAGNOSIS AND TESTING

42LE GENERAL DIAGNOSIS

CAUTION: Before attempting any repair on the 42LE Four Speed Automatic Transaxle, always check for proper shift linkage adjustment. Also check for diagnostic trouble codes with the DRB scan tool and the 42LE Transaxle Diagnostic Procedure Manual.

42LE automatic transaxle malfunctions may be caused by these general conditions:

- Poor engine performance
- Improper adjustments
- Hydraulic malfunctions
- Mechanical malfunctions
- Electronic malfunctions

When diagnosing a problem always begin with recording the complaint. The complaint should be defined as specific as possible. Include the following checks:

- Temperature at occurrence (cold, hot, both)
- Dynamic conditions (acceleration, deceleration, upshift, cornering)
- Elements in use when condition occurs (what gear is transaxle in during condition)
- Road and weather conditions
- Any other useful diagnostic information.

After noting all conditions, check the easily accessible variables:

- Fluid level and condition
- Shift linkage adjustment
- Diagnostic trouble code inspection

Then perform a road test to determine if the problem has been corrected or that more diagnosis is necessary. If the problem exists after the preliminary tests and corrections are completed, hydraulic pressure checks should be performed.

ROAD TEST

Prior to performing a road test, verify that the fluid level, fluid condition, and linkage adjustment have been approved.

During the road test, the transaxle should be operated in each position to check for slipping and any variation in shifting.

If the vehicle operates properly at highway speeds, but has poor acceleration, the converter stator overrunning clutch may be slipping. If acceleration is normal, but high throttle opening is needed to maintain highway speeds, the converter stator clutch may have seized. Both of these stator defects require replacement of the torque converter and thorough transaxle cleaning.

Slipping clutches can be isolated by comparing the "Elements in Use" chart with clutch operation encountered on a road test. This chart identifies which clutches are applied at each position of the selector lever.

A slipping clutch may also set a DTC and can be determined by operating the transaxle in all selector positions.

DIAGNOSIS AND TESTING (Continued)

ELEMENTS IN USE AT EACH POSITION OF SELECTOR LEVER

Shift Lever Position	INPUT CLUTCHES			HOLDING CLUTCHES	
	Underdrive	Overdrive	Reverse	2/4	Low/Reverse
P - PARK					X
R - REVERSE			X		X
N - NEUTRAL					X
OD - OVERDRIVE					
First	X				X
Second	X			X	
Direct	X	X			
Overdrive		X		X	
D - DRIVE*					
First	X				X
Second	X			X	
Direct	X	X			
L - LOW*					
First	X				X
Second	X			X	
Direct	X	X			

* Vehicle upshift and downshift speeds are increased when in these selector positions.

The process of elimination can be used to detect any unit which slips and to confirm proper operation of good units. Road test analysis can diagnose slipping units, but the cause of the malfunction cannot be determined. Practically any condition can be caused by leaking hydraulic circuits or sticking valves.

HYDRAULIC PRESSURE TESTS

Pressure testing is a very important step in the diagnostic procedure. These tests usually reveal the cause of most transaxle problems.

Before performing pressure tests, be certain that fluid level and condition, and shift cable adjustments have been checked and approved. Fluid must be at operating temperature (150 to 200 degrees F.).

Install an engine tachometer, raise vehicle on hoist which allows front wheels to turn, and position tachometer so it can be read.

Using special adapters (L-4559), attach 300 psi gauge(s) (C-3293SP) to port(s) required for test being conducted.

Test port locations are shown in (Fig. 29).

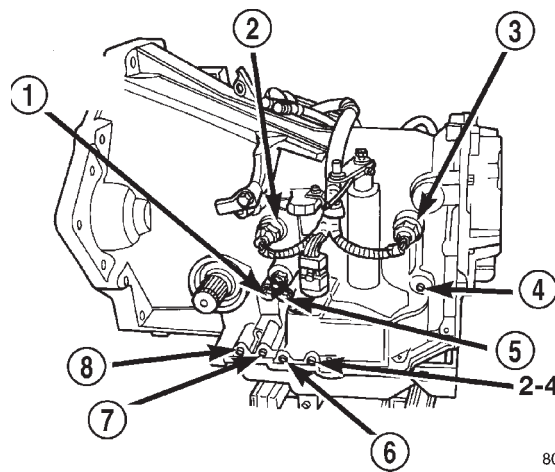

80ad0870

Fig. 29 Pressure Taps

- 1 - TORQUE CONVERTER CLUTCH OFF
- 2 - TURBINE SPEED SENSOR
- 3 - OUTPUT SPEED SENSOR
- 4 - LOW/REVERSE
- 5 - REVERSE
- 6 - UNDERDRIVE
- 7 - TORQUE CONVERTER CLUTCH ON
- 8 - OVERDRIVE

DIAGNOSIS AND TESTING (Continued)

TEST ONE-SELECTOR IN L (1st Gear)

NOTE: This test checks pump output, pressure regulation and condition of the low/reverse clutch hydraulic circuit and shift schedule.

- (1) Attach pressure gauge to the low/reverse clutch tap.
- (2) Move selector lever to the L position.
- (3) Allow vehicle wheels to turn and increase throttle opening to achieve an indicated vehicle speed to 20 mph.
- (4) Low/reverse clutch pressure should read 115 to 145 psi.

TEST TWO-SELECTOR IN DRIVE (Second Gear)

NOTE: This test checks the underdrive clutch hydraulic circuit as well as the shift schedule.

- (1) Attach gauge to the underdrive clutch tap.
- (2) Move selector lever to the 3 position.
- (3) Allow vehicle wheels to turn and increase throttle opening to achieve an indicated vehicle speed of 30 mph.
- (4) In second gear the underdrive clutch pressure should read 110 to 145 psi.

TEST TWO A-SELECTOR IN OD (Fourth Gear)

NOTE: This test checks the underdrive clutch hydraulic circuit as well as the shift schedule.

- (1) Attach gauge to the underdrive clutch tap.
- (2) Move selector lever to the OD position.
- (3) Allow wheels to rotate freely and increase throttle opening to achieve an indicated speed of 40 mph.
- (4) Underdrive clutch pressure should read below 5 psi. If not, than either the solenoid assembly or TCM is at fault.

TEST THREE-SELECTOR IN OVERDRIVE (Third and Second Gear)

NOTE: This test checks the overdrive clutch hydraulic circuit as well as the shift schedule.

- (1) Attach gauge to the overdrive clutch tap.
- (2) Move selector lever to the OD position.
- (3) Allow vehicle wheels to turn and increase throttle opening to achieve an indicated vehicle speed of 20 mph.
- (4) Overdrive clutch pressure should read 74 to 95 psi.
- (5) Move selector lever to the 3 position and increase indicated vehicle speed to 30 mph.

- (6) The vehicle should be in second gear and overdrive clutch pressure should be less than 5 psi.

TEST FOUR-SELECTOR IN OD (Fourth Gear)

NOTE: This test checks the 2/4 clutch hydraulic circuit.

- (1) Attach gauge to the 2/4 clutch tap.
- (2) Move selector lever to the OD position.
- (3) Allow vehicle front wheels to turn and increase throttle opening to achieve an indicated vehicle speed of 30 mph. Vehicle should be in fourth gear.
- (4) The 2/4 clutch pressure should read 75 to 95 psi.

TEST FIVE-SELECTOR IN OVERDRIVE (Fourth Gear, CC on)

NOTE: These tests checks the torque converter clutch hydraulic circuit.

- (1) Attach gauge to the torque converter clutch off pressure tap.
- (2) Move selector lever to the overdrive position.
- (3) Allow vehicle wheels to turn and increase throttle opening to achieve an indicated vehicle speed of 50 mph. Vehicle should be in 4th gear, CC on.

CAUTION: Both wheels must turn at the same speed.

- (4) Torque converter clutch off pressure should be less than 5 psi.
- (5) Now attach the gauge to the torque converter clutch on pressure tap.
- (6) Move selector to the overdrive position.
- (7) Allow vehicle wheels to turn and increase throttle opening to achieve an indicated vehicle speed of 50 mph.
- (8) Verify the torque converter clutch is applied mode using the RPM display of the DRB scan tool.
- (9) Torque converter clutch on pressure should be 60-90 psi.

TEST SIX-SELECTOR IN REVERSE

NOTE: This test checks the reverse clutch hydraulic circuit.

- (1) Attach gauge to the reverse and low/reverse clutch tap.
- (2) Move selector lever to the reverse position.
- (3) Read reverse clutch pressure with output stationary (foot on brake) and throttle opened to achieve 1500 rpm.
- (4) Reverse and low/reverse clutch pressure should read 165 to 235 psi.

DIAGNOSIS AND TESTING (Continued)

TEST RESULT INDICATIONS

(1) If proper line pressure is found in any one test, the pump and pressure regulator are working properly.

(2) Low pressure in all positions indicates a defective pump, a clogged filter, or a stuck pressure regulator valve.

(3) Clutch circuit leaks are indicated if pressures do not fall within the specified pressure range.

(4) If the overdrive clutch pressure is greater than 5 psi in Step 6 of Test Three, a worn reaction shaft seal ring or a defective solenoid assembly is indicated.

(5) If the underdrive clutch pressure is greater than 5 psi in Step 4 of Test Two-A, a defective solenoid/pressure switch assembly or TCM is the cause.

CLUTCH AIR PRESSURE TESTS

Inoperative clutches can be located by substituting air pressure for fluid pressure. The clutches may be tested by applying air pressure to their respective passages after the valve body has been removed. Use Special Tool 6599-1 and 6599-2 to perform test (Fig. 30).

To make air pressure tests, proceed as follows:

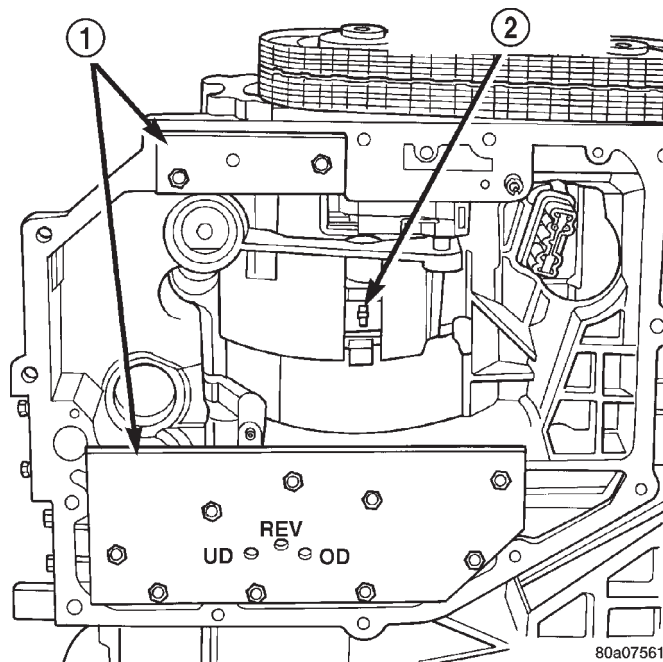

Fig. 30 Air Pressure Test Plate

- 1 - AIR PRESSURE TEST PLATES
- 2 - 2/4 CLUTCH RETAINER HOLE

ALL PRESSURE SPECIFICATIONS ARE PSI(ON HOIST, WITH FRONT WHEELS FREE TO TURN)

Gear Selector Position	Actual Gear	PRESSURE TAPS						
		Underdrive Clutch	Overdrive Clutch	Reverse Clutch	Torque Converter Clutch Off	2/4 CLUTCH	Low/Reverse Clutch	
PARK 0 mph	* PARK	0-2	0-5	0-2	60-110	0-2	X 115-145	
REVERSE 0 mph	* REVERSE	0-2	0-7	165-235	50-100	0-2	165-235	
NEUTRAL 0 mph	* NEUTRAL	0-2	0-5	0-2	60-110	0-2	115-145	
L 20 mph	# FIRST	110-145	0-5	0-2	60-110	0-2	115-145	
3 30 mph	# SECOND	110-145	0-5	0-2	60-110	115-145	0-2	
3 45 mph	# DIRECT	75-95	75-95	0-2	60-90	0-2	0-2	
OD 30 mph	# OVERDRIVE	0-2	75-95	0-2	60-90	75-95	0-2	
OD 50 mph	# OVERDRIVE WITH TCC	0-2	75-95	0-2	0-5	75-95	0-2	

*Engine speed at 1500 rpm

#CAUTION: Both front wheels must be turning at same speed.

42LE PRESSURE CHECK SPECIFICATIONS

DIAGNOSIS AND TESTING (Continued)

NOTE: The compressed air supply must be free of all dirt and moisture. Use a pressure of 30 psi.

Remove oil pan and valve body. See Valve body recondition.

Apply air pressure to the holes in the special tool, one at a time.

Listen for the clutch to apply. It will give a slight thud sound. If a large amount of air is heard escaping, the transaxle must be removed from vehicle, disassembled and all seals inspected.

OVERDRIVE CLUTCH

Apply air pressure to the overdrive clutch apply passage and watch for the push/pull piston to move forward. The piston should return to its starting position when the air pressure is removed.

UNDERDRIVE CLUTCH

Because this clutch piston cannot be seen, its operation is checked by function. Air pressure is applied to the low/reverse or the 2/4 clutches. This locks the output shaft. Use a piece of rubber hose wrapped around the input shaft and a pair of clamp-on pliers to turn the input shaft. Next apply air pressure to the underdrive clutch (Fig. 31). The input shaft should not rotate with hand torque. Release the air pressure and confirm that the input shaft will rotate.

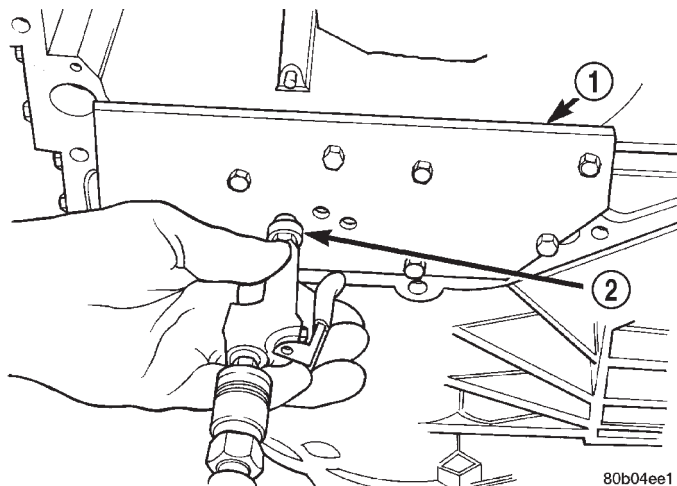

Fig. 31 Testing Underdrive Clutch

1 - AIR PRESSURE TEST PLATE 6599-1

2 - AIR NOZZLE

REVERSE CLUTCH

Apply air pressure to the reverse clutch apply passage and watch for the push/pull piston to move rearward. The piston should return to its starting position when the air pressure is removed.

2/4 CLUTCH

Apply air pressure to the feed hole located on the 2/4 clutch retainer. Look in the area where the 2/4 piston contacts the first separator plate and watch carefully for the 2/4 piston to move rearward. The piston should return to its original position after the air pressure is removed.

LOW/REVERSE CLUTCH

Apply air pressure to the low/reverse clutch feed hole passage. Look in the area where the low/reverse piston contacts the first separator plate. Watch carefully for the piston to move forward. The piston should return to its original position after the air pressure is removed.

FLUID LEAKAGE

The 42LE is a dual sump transaxle. The transaxle uses both automatic transaxle fluid (ATF) for the main sump and hypoid gear lube for the differential sump. When diagnosing a leak, it is important to distinguish which type of fluid is leaking. Factory fill ATF is dyed red, while differential hypoid oil is brown in color and has a distinctive odor.

There are two seals at the boundary of the two sumps. There is a weep hole in the right side of the transaxle case (Fig. 32) which vents the area between the two seals. If oil is leaking from the weep hole, there is at least one seal leaking. Never plug the weep hole to correct a leaking condition. Plugging the weep hole could result in contaminating one or both transaxle sumps, low oil level, poor transaxle performance or transaxle failure. In order to correctly repair this type of leak the transaxle must be removed from the vehicle and both transfer shaft seals replaced. Refer to Transfer Shaft Seal Replacement procedure in this section.

FLUID LEAKAGE-TORQUE CONVERTER HOUSING AREA

(1) Check for source of leakage. Fluid leakage from the torque converter area may originate from an engine oil leak, a differential oil leak or an ATF oil leak. The area should be examined closely.

(2) Prior to removing the transaxle, perform the following checks:

- When leakage is determined to be automatic transmission fluid, check fluid level prior to removal of the transaxle and torque converter.
- High oil level can result in oil leakage out the vent. If the fluid level is high, adjust to proper level.
- After performing this operation, inspect for leakage. If a leak persists, perform the following operation on the vehicle. This will determine if it is the torque converter or transaxle that is leaking.

DIAGNOSIS AND TESTING (Continued)

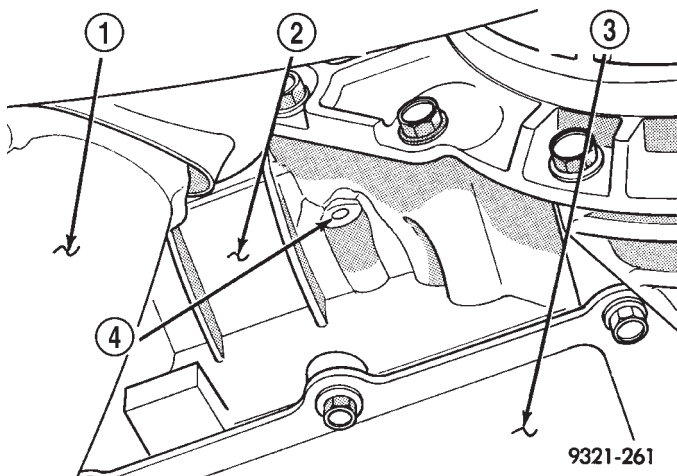

Fig. 32 Weep Hole Location

- 1 - RIGHT EXHAUST PIPE
- 2 - TRANSAXLE CASE
- 3 - TRANSAXLE OIL PAN
- 4 - WEEP HOLE

TORQUE CONVERTER LEAKAGE

Possible sources of torque converter leakage are:

- Torque converter weld leaks at the outside (peripheral) weld.
- Torque converter hub weld.

NOTE: Hub weld is inside and not visible. Do not attempt to repair. Replace torque converter.

FLUID LEAKAGE—DIFFERENTIAL HOUSING AREA

The differential uses Mopar® 75w-90 Fuel Saving petroleum based hypoid gear lube. It can be distinguished from ATF by its brown color (ATF is dyed red). Also gear lube has a distinctive odor (hypoid smell).

(1) If it is suspected that the leakage is gear lube, check the differential for proper fluid level. High oil level can result in leakage from the differential vent.

CAUTION: A crushed vent baffle will cause oil to leak from vent hose.

- (2) If fluid level is correct, add 1/4 to 1/2 ounce of leak detecting florescent dye to the differential.
- (3) Clean the suspect area of the transaxle with solvent.
- (4) Road test the vehicle until the leak reoccurs.
- (5) Using a black light determine the source of the leak and repair as required.
- (6) Do not add oil dye to both the ATF sump and the differential sump at the same time. This can cause confusion when trying to pinpoint a leak source.

FLUID LEAKAGE-TORQUE CONVERTER HOUSING AREA

When diagnosing converter housing fluid leaks, three actions must be taken before repair:

- (1) Verify proper transmission fluid level.
- (2) Verify that the leak originates from the converter housing area and is transmission fluid.
- (3) Determine the true source of the leak.

Fluid leakage at or around the torque converter area may originate from an engine oil leak (Fig. 33). The area should be examined closely. Factory fill fluid is red and, therefore, can be distinguished from engine oil.

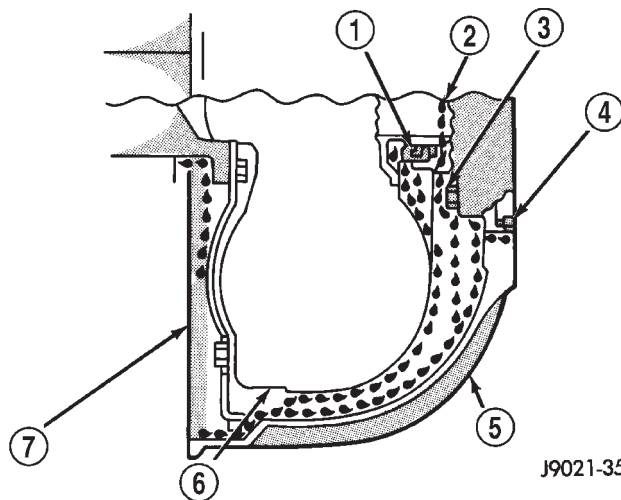

Fig. 33 Converter Housing Leak Paths

- 1 - PUMP SEAL
- 2 - PUMP VENT
- 3 - PUMP BOLT
- 4 - PUMP GASKET
- 5 - CONVERTER HOUSING
- 6 - CONVERTER
- 7 - REAR MAIN SEAL LEAK

Some suspected converter housing fluid leaks may not be leaks at all. They may only be the result of residual fluid in the converter housing, or excess fluid spilled during factory fill, or fill after repair. Converter housing leaks have several potential sources. Through careful observation, a leak source can be identified before removing the transmission for repair.

Pump seal leaks tend to move along the drive hub and onto the rear of the converter (Fig. 33). Pump o-ring or pump body leaks follow the same path as a seal leak. Pump attaching bolt leaks are generally deposited on the inside of the converter housing and not on the converter itself. Pump seal or gasket leaks usually travel down the inside of the converter housing (Fig. 33).

DIAGNOSIS AND TESTING (Continued)

TORQUE CONVERTER LEAKAGE

Possible sources of torque converter leakage are:

- Torque converter weld leaks at the outside diameter weld (Fig. 34).
- Torque converter hub weld (Fig. 34).

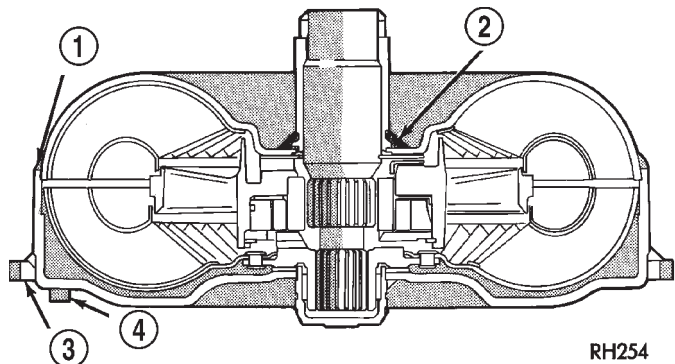

Fig. 34 Converter Leak Points—Typical

- 1 - OUTSIDE DIAMETER WELD
- 2 - TORQUE CONVERTER HUB WELD
- 3 - STARTER RING GEAR
- 4 - LUG

BRAKE/TRANSMISSION SHIFT INTERLOCK SYSTEM (COLUMN SHIFT)

The following chart describes the normal operation of the Brake Transmission Shift Interlock (BTSI) system. If the "expected response" differs from the vehicle's response, then system repair and/or adjustment is necessary.

Refer to the following chart that expected shifter response, depending on ignition key/switch (Fig. 35) and brake pedal positions.

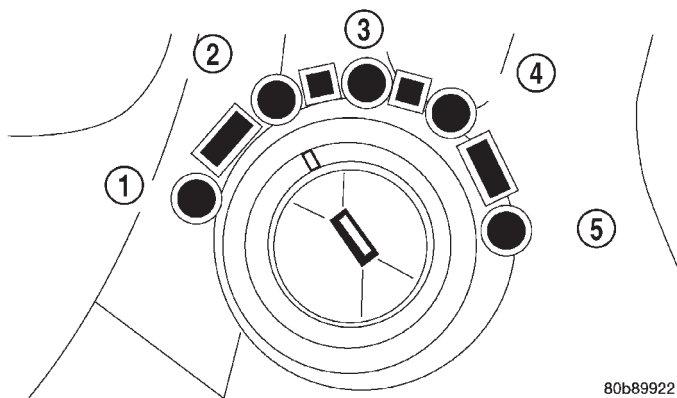

Fig. 35 Ignition Key/Switch Positions

- 1 - ACC
- 2 - LOCK
- 3 - OFF
- 4 - ON/RUN
- 5 - START

ACTION	EXPECTED RESPONSE
1. Turn key to the "OFF" position.	1. Shifter CAN be shifted out of park.
2. Turn key to the "ON/RUN" position.	2. Shifter CANNOT be shifted out of park.
3. Turn key to the "ON/RUN" position and depress the brake pedal.	3. Shifter CAN be shifted out of park.
4. Leave shifter in any gear and try to return key to the "LOCK" or "ACC" position.	4. Key cannot be returned to the "LOCK" or "ACC" position.
5. Return shifter to "PARK" and try to remove the key.	5. Key can be removed (after returning to "LOCK" position).
6. With the key removed, try to shift out of "PARK".	6. Shifter cannot be shifted out of "PARK".
NOTE: Any failure to meet these expected responses requires system adjustment or repair.	

If the shift lever cannot be moved out of the PARK position, refer to Shift Lever Locked In Place below. If the shift lever can be shifted out of PARK without the brake pedal depressed, refer to Circuit Test below.

SHIFT LEVER LOCKED IN PLACE

(1) Remove the instrument panel cover below the steering column, then remove the steering column shrouds to gain access to the brake transmission shift interlock (BTSI) solenoid.

(2) Disconnect the wire connector from the rear of the BTSI solenoid.

(3) Insert the ignition key and turn it to the ON position.

(4) With the brakes applied, try shifting the transmission shift lever out of the PARK position.

- If the lever now moves freely in and out of PARK, perform the Circuit Test below.

- If the shift lever still does not move from the PARK position, remove the BTSI solenoid from the shift lever assembly.

If the shift lever now moves freely in and out of the park position, the BTSI solenoid is faulty and must be replaced. If the shift lever still does not move from the park position, the problem is in the shift lever assembly or the ignition interlock cassette.

CIRCUIT TEST

(1) Check the system fuse in the junction block (An open or blown fuse would allow the shift lever to be moved in and out of the PARK position without the brake pedal applied).

DIAGNOSIS AND TESTING (Continued)

(2) Remove the instrument panel cover below the steering column, then remove the steering column shrouds to gain access to the brake transmission shift interlock (BTSI) solenoid.

(3) Disconnect the wire connector from the rear of the BTSI solenoid.

(4) Insert the ignition key and turn it to the ON position.

(5) Back-probe the wire connector's terminal number 2 with a test light. The test light should illuminate. If not, there is an open or short in the ignition feed circuit leading to the BTSI solenoid. Repair the open or short.

(6) Next, back-probe the wire connector with a test light, placing the test light in series between the two wires. At this point, the test light should illuminate. If not, there is an open in the ground circuit or brake lamp switch. Repair the open or replace brake lamp switch as necessary.

(7) Depress the brake pedal. The test light should go out. If it does not, there is a short in the ground circuit or brake lamp switch. Repair the short or replace brake lamp switch as necessary.

(8) Reconnect the wire connector to the solenoid.

If the circuit passes the above test and the shift lever can still be moved freely in and out of PARK without the brake pedal depressed, replace the BTSI solenoid.

BRAKE/TRANSMISSION SHIFT INTERLOCK SYSTEM (FLOOR SHIFT)

The following chart describes the normal operation of the Brake Transmission Shift Interlock (BTSI) system. If the "expected response" differs from the vehicle's response, then system repair and/or adjustment is necessary.

Refer to the following chart that expected shifter response, depending on ignition key/switch (Fig. 36) and brake pedal positions.

If the floor shifter cannot be moved out of the PARK position, refer to Shifter Locked In Place below. If the shift lever can be shifted out of PARK without the brake pedal depressed, refer to Circuit Test below.

SHIFTER LOCKED IN PLACE

(1) Remove the instrument panel cover below the steering column, then remove the steering column shrouds to gain access to the brake transmission shift interlock (BTSI) solenoid. The solenoid is part of the interlock cable assembly.

(2) Disconnect the wire connector from the rear of the BTSI solenoid.

(3) Insert the ignition key and turn it to the ON position.

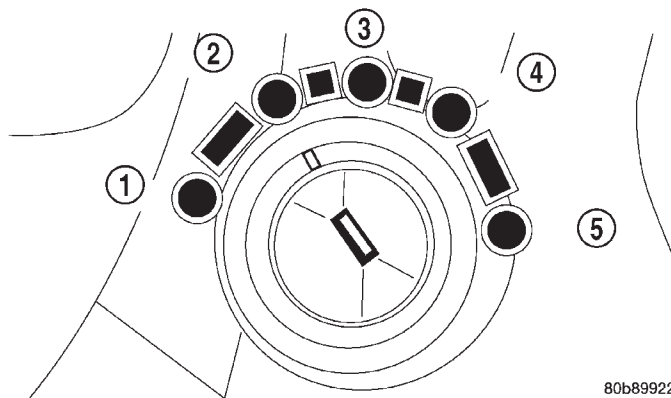

80b89922

Fig. 36 Ignition Key/Switch Positions

- 1 - ACC
- 2 - LOCK
- 3 - OFF
- 4 - ON/RUN
- 5 - START

ACTION	EXPECTED RESPONSE
1. Turn key to the "OFF" position.	1. Shifter CAN be shifted out of park.
2. Turn key to the "ON/RUN" position.	2. Shifter CANNOT be shifted out of park.
3. Turn key to the "ON/RUN" position and depress the brake pedal.	3. Shifter CAN be shifted out of park.
4. Leave shifter in any gear and try to return key to the "LOCK" or "ACC" position.	4. Key cannot be returned to the "LOCK" or "ACC" position.
5. Return shifter to "PARK" and try to remove the key.	5. Key can be removed (after returning to "LOCK" position).
6. With the key removed, try to shift out of "PARK".	6. Shifter cannot be shifted out of "PARK".
NOTE: Any failure to meet these expected responses requires system adjustment or repair.	

(4) With the brakes applied, try moving the shifter out of the PARK position.

- If the lever now moves freely in and out of PARK, perform the Circuit Test below.
- If the shift lever still does not move from the PARK position, remove the BTSI solenoid from the shift lever assembly.

If the shift lever now moves freely in and out of the park position, the BTSI solenoid is faulty and the interlock cable must be replaced. If the shift lever still does not move from the park position, the problem is in the shift lever assembly or the ignition interlock cassette.

DIAGNOSIS AND TESTING (Continued)

CIRCUIT TEST

(1) Check the system fuse in the junction block (An open or blown fuse would allow the shift lever to be moved in and out of the PARK position without the brake pedal applied).

(2) Remove the instrument panel cover below the steering column, then remove the steering column shrouds to gain access to the brake transmission shift interlock (BTSI) solenoid.

(3) Disconnect the wire connector from the rear of the BTSI solenoid.

(4) Insert the ignition key and turn it to the ON position.

(5) Back-probe the wire connector's terminal number 2 with a test light. The test light should illuminate. If not, there is an open or short in the ignition feed circuit leading to the BTSI solenoid. Repair the open or short.

(6) Next, back-probe the wire connector with a test light, placing the test light in series between the two wires. At this point, the test light should illuminate. If not, there is an open in the ground circuit or brake lamp switch. Repair the open or replace brake lamp switch as necessary.

(7) Depress the brake pedal. The test light should go out. If it does not, there is a short in the ground circuit or brake lamp switch. Repair the short or replace brake lamp switch as necessary.

(8) Reconnect the wire connector to the solenoid.

If the circuit passes the above test and the shifter can still be moved freely in and out of PARK without the brake pedal depressed, replace the interlock cable.

SHIFT POSITION INDICATOR

The transmission range sensor (on the valve body) sends a signal to the TCM on the position of the transaxle manual valve lever. The TCM receives the switch signal and processes the data. The TCM sends the Shift Lever Position (SLP) information to the BCM via the communication bus. The BCM then outlines the appropriate shifter position indicator in the instrument cluster.

If a problem arises with the shifter position indicator, consult the following chart for diagnostic information. If the malfunction cannot be corrected using the chart, consult the proper diagnostic manual.

To replace the shifter position indicator, refer to Group 8E, Instrument Panel And Gauges.

AUTOSTICK

The autostick feature will be deactivated if one of the following conditions occur:

CONDITION	POSSIBLE CAUSE
ALL PRND3L (PRND1234 if Autostick equipped) DISPLAY LIGHTS "ON" IN P&N GEAR POSITIONS	Check wiring and connectors
	Faulty TRS
	Faulty manual lever
ALL DISPLAY LIGHTS "ON" IN ALL GEAR POSITIONS	Check wiring & connectors
	Faulty trans. range sensor
	Faulty manual lever
ALL DISPLAY LIGHTS "OFF"	Normal transient condition between P&R and R&N gear positions
	Check shift lever linkage
	BCM malfunction
	Check wiring and connectors
ALL DISPLAY LIGHTS "OFF" ACCOMPANIED BY A "NO BUS" MESSAGE	Faulty instrument cluster
	Communication bus malfunction
DISPLAY LIGHTS OUT OF SEQUENCE WITH SHIFT LEVER	Communication bus malfunction
	Check wiring and connectors
	Faulty TRS
	Faulty manual lever
	Communication bus malfunction

- DTC P0705–Check Shifter Signal–usually accompanied by all PRNDL lights turning on in Park and Neutral. This will result in a DTC P0705 if three such errors are detected after any one “key-on”.

- DTC P1796–Autostick Input Circuit
- DTC P1797–Manual Shift Overheat–(Transmission oil temperature >275° F) or (Engine coolant temperature >255° F).

Acceptable powertrain temperature must be achieved to reactivate Autostick after a high temperature fault:

- Transmission Oil Temperature <255° F
- Engine Coolant Temperature <240° F

SERVICE PROCEDURES

FLUID LEVEL AND CONDITION CHECK

NOTE: The transmission and differential have separate oil sumps. The transmission sump requires automatic transmission fluid. The differential sump requires petroleum based hypoid gear lube.

TRANSMISSION SUMP

FLUID LEVEL CHECK

The transmission sump has a dipstick to check oil similar to most automatic transmissions. It is located on the left side of the engine. Be sure to wipe all dirt from dipstick handle before removing.

The torque converter fills in both the P Park and N Neutral positions. Place the selector lever in P Park to be sure that the fluid level check is accurate. **The engine should be running at idle speed for at least one minute, with the vehicle on level ground.** At normal operating temperature (approximately 82 C. or 180 F.), the fluid level is correct if it is in the HOT region (cross-hatched area) on the oil level indicator (Fig. 37). The fluid level will be approximately one-quarter inch above the lower hole of the dipstick at 70° F fluid temperature.

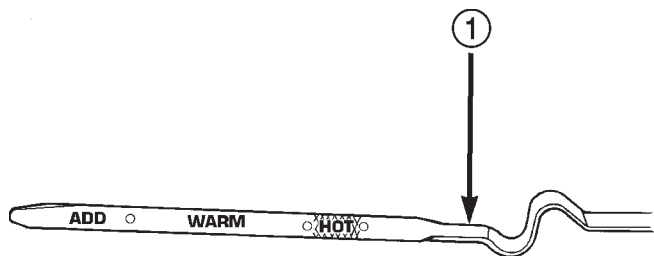

80b04ee2

Fig. 37 Dipstick Markings

1 – TRANSAXLE DIPSTICK

FLUID LEVEL CHECK USING DRB

NOTE: Engine and Transaxle should be at normal operating temperature before performing this procedure.

- (1) Start engine and apply parking brake.
- (2) Hook up DRBIII scan tool and select transmission.
- (3) Select sensors.
- (4) Read the transmission temperature value.

(5) Compare the fluid temperature value with the chart.

(6) Adjust transmission fluid level shown on the dipstick according to the chart.

(7) Check transmission for leaks.

Low fluid level can cause a variety of conditions because it allows the pump to take in air along with the fluid. As in any hydraulic system, air bubbles make the fluid spongy, therefore, pressures will be low and build up slowly.

Improper filling can also raise the fluid level too high. When the transaxle has too much fluid, the gears churn up foam and cause the same conditions which occur with a low fluid level.

In either case, air bubbles can cause overheating and/or fluid oxidation, and varnishing. This can interfere with normal valve, clutch, and accumulator operation. Foaming can also result in fluid escaping from the transaxle vent where it may be mistaken for a leak.

Along with fluid level, it is important to check the condition of the fluid. When the fluid smells burned, and is contaminated with metal or friction material particles, a complete transaxle recondition is needed. Be sure to examine the fluid on the dipstick closely. If there is any doubt about its condition, drain out a sample for a double check.

After the fluid has been checked, seat the dipstick fully to seal out water and dirt.

The transmission fluid level should be inspected at least every six months.

DIFFERENTIAL SUMP

The differential sump is checked separately from the transmission. A fill plug located on the side of the transaxle must be removed to check fluid level. The fluid should be level with the bottom of the fill hole. The differential capacity is .946 liters (32 ounces).

Inspect the differential area during engine oil changes for any leaks. If leakage is present, determine the source of the leak and repair as required. Remove the fill plug and verify the proper level. Adjust if needed.

FLUID AND FILTER SERVICE—TRANSMISSION

NOTE: Refer to Group 0, Lubrication and Maintenance, or the vehicle owner's manual, for the recommended maintenance (fluid/filter change) intervals for this transaxle.

NOTE: The 42LE Transaxle has separate transmission and differential fluid sumps. Refer to Fluid Drain and Refill—Differential for differential fluid service.

SERVICE PROCEDURES (Continued)

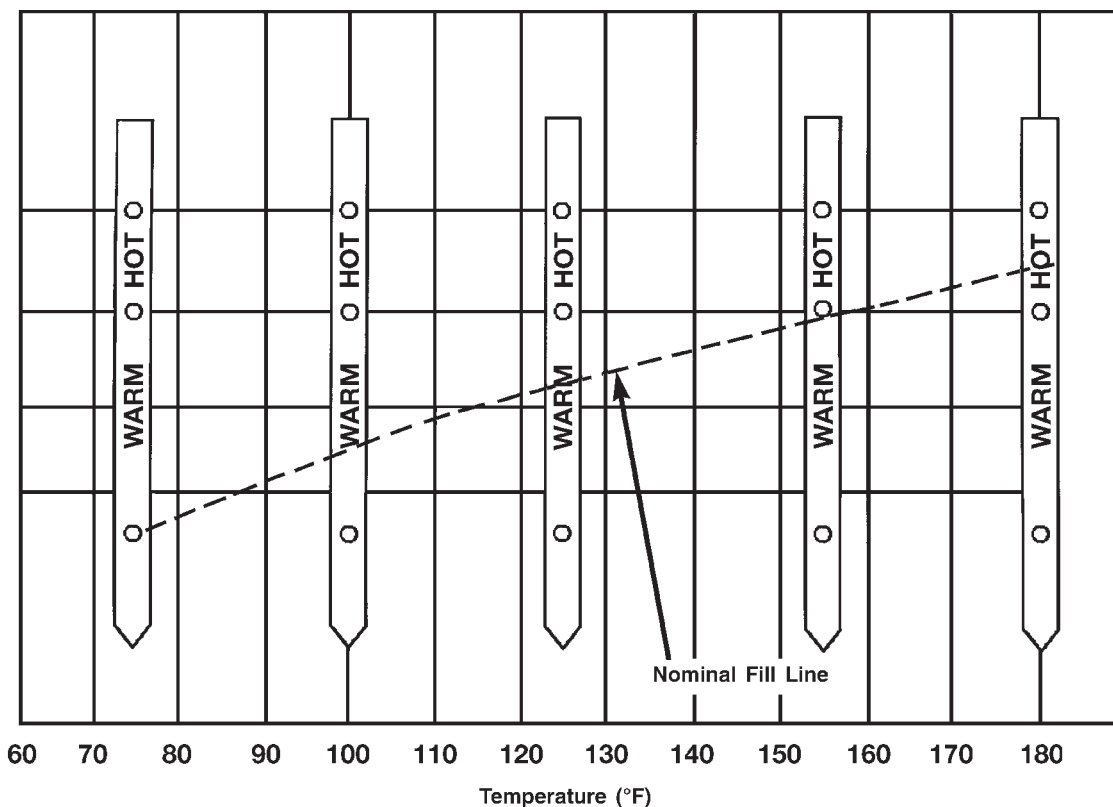

80a0141t

Transmission Fluid Temperature Chart

NOTE: Only fluids of the type labeled Mopar® ATF+4 (Automatic Transmission Fluid) Type 9602 should be used. A filter change should be made at the time of the transmission oil change. The magnet (on the inside of the oil pan) should also be cleaned with a clean, dry cloth.

NOTE: If the transaxle is disassembled for any reason, the fluid and filter should be changed.

FLUID/FILTER SERVICE (RECOMMENDED)

- (1) Raise vehicle on a hoist (See Lubrication, Group 0). Place a drain container with a large opening, under transaxle oil pan.
- (2) Loosen pan bolts and tap the pan at one corner to break it loose allowing fluid to drain, then remove the oil pan.
- (3) Install a new filter and o-ring on bottom of the valve body and tighten retaining screws to 5 N·m (40 in. lbs.).
- (4) Clean the oil pan and magnet. Reinstall pan using new Mopar Silicone Adhesive sealant. Tighten oil pan bolts to 19 N·m (165 in. lbs.).
- (5) Pour four quarts of Mopar® ATF+4 (Automatic Transmission Fluid) Type 9602 through the dipstick opening.

(6) Start engine and allow to idle for at least one minute. Then, with parking and service brakes applied, move selector lever momentarily to each position, ending in the park or neutral position.

(7) Check the transaxle fluid level and add an appropriate amount to bring the transaxle fluid level to 3mm (1/8 in.) below the “ADD” mark on the dipstick (Fig. 38).

(8) Recheck the fluid level after the transaxle has reached normal operating temperature (180°F).

(9) To prevent dirt from entering transaxle, make certain that dipstick is fully seated into the dipstick opening.

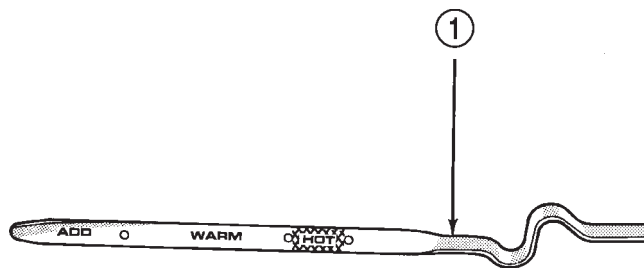

9321-323

Fig. 38 Dipstick Markings

1 - TRANSAXLE DIPSTICK

SERVICE PROCEDURES (Continued)

ALTERNATIVE MAINTENANCE METHODS

TRANSAXLE FLUID EXCHANGER METHOD

CAUTION: The use of any fluid exchanger that introduces additives into the transaxle is not recommended.

(1) To perform the transaxle fluid exchange, the transaxle must be at operating temperature. Drive the vehicle until it reaches full operating temperature.

(2) Obtain a suitable transaxle fluid exchanger and verify the tank is clean and dry.

(3) Fill the tank to the recommended fill capacity with Mopar® ATF+4 Type 9602.

(4) Connect the machine to the vehicle following the manufacturers instructions. Perform the exchange procedure following the instructions provided with the machine.

(5) Once machine has completed the fluid exchange. Check the fluid level and condition and fill to proper level with Mopar® ATF+4 Type 9602. Refer to Fluid Level and Condition Check in this group for the proper fluid "top-off" procedure.

NOTE: Verify that the transaxle cooler lines are tightened to proper specifications. Cooler line torque specification is 2 N•m (18 in. lbs.).

DIPSTICK TUBE FLUID SUCTION METHOD

(1) When performing the fluid suction method, make sure the transaxle is at full operating temperature.

(2) To perform the dipstick tube fluid suction method, use a suitable fluid suction device (Vacula™ or equivalent).

(3) Insert the fluid suction line into the dipstick tube.

NOTE: Verify that the suction line is inserted to the lowest point of the transaxle oil pan. This will ensure complete evacuation of the fluid in the pan.

(4) Follow the manufacturers recommended procedure and evacuate the fluid from the transaxle.

(5) Remove the suction line from the dipstick tube.

(6) Pour four quarts of Mopar® ATF+4 (Automatic Transmission Fluid) Type 9602 through the dipstick opening.

(7) Start engine and allow to idle for at least one minute. Then, with parking and service brakes applied, move selector lever momentarily to each position, ending in the park or neutral position.

(8) Check the transaxle fluid level and add an appropriate amount to bring the transaxle fluid level

to 3mm (1/8 in.) below the "ADD" mark on the dipstick (Fig. 38).

(9) Recheck the fluid level after the transaxle has reached normal operating temperature (180°F).

(10) To prevent dirt from entering transaxle, make certain that dipstick is fully seated into the dipstick opening.

FLUID DRAIN AND REFILL-DIFFERENTIAL SUMP

The differential fluid can be drained and filled without having to remove the transaxle from the vehicle. Use only Mopar® Fuel Saving 75W-90 petroleum based hypoid gear lubricant when replacing fluid.

REMOVAL

(1) Raise vehicle on hoist.

(2) Remove differential drain plug located on the bottom of the differential housing. Allow the fluid to drain into an oil drain pan.

(3) Remove differential fill plug located on the differential side cover. This will assist the flow of fluid from the drain plug hole.

INSTALLATION

(1) Install drain plug into differential housing. Tighten drain plug to 7 N•m (60 in. lbs.)

(2) Fill differential with Mopar® Fuel Saving 75W-90 petroleum based hypoid gear lubricant. The fluid should be level with the bottom of the fill hole. The differential capacity is .946 liters (32 ounces).

CAUTION: Overfilling the differential can result in oil foaming and/or oil loss from the differential vent.

(3) Install differential fill plug. Tighten fill plug to 47 N•m (35 ft. lbs.).

ALUMINUM THREAD REPAIR

Damaged or worn threads in the aluminum transaxle case and valve body can be repaired by the use of Heli-Coils, or equivalent. This repair consists of drilling out the worn-out damaged threads. Then tap the hole with a special Heli-Coil tap, or equivalent, and installing a Heli-Coil insert, or equivalent, into the hole. This brings the hole back to its original thread size.

Heli-Coil, or equivalent, tools and inserts are readily available from most automotive parts suppliers.

FLUSHING COOLERS AND TUBES

When a transaxle failure has contaminated the fluid, the oil cooler(s) must be flushed. The cooler bypass valve in the transaxle must be replaced also. The torque converter must also be replaced with an

SERVICE PROCEDURES (Continued)

exchange unit. This will insure that metal particles or sludged oil are not later transferred back into the reconditioned (or replaced) transaxle.

The recommended procedure for cooler flushing is to use Tool 6906 Cooler Flusher.

WARNING: WEAR PROTECTIVE EYEWEAR THAT MEETS THE REQUIREMENTS OF OSHA AND ANSI Z87.1-1968. WEAR STANDARD INDUSTRIAL RUBBER GLOVES.

KEEP LIGHTED CIGARETTES, SPARKS, FLAMES, AND OTHER IGNITION SOURCES AWAY FROM THE AREA TO PREVENT THE IGNITION OF COMBUSTIBLE LIQUIDS AND GASES. KEEP A CLASS (B) FIRE EXTINGUISHER IN THE AREA WHERE THE FLUSHER WILL BE USED.

KEEP THE AREA WELL VENTILATED.

DO NOT LET FLUSHING SOLVENT COME IN CONTACT WITH YOUR EYES OR SKIN: IF EYE CONTAMINATION OCCURS, FLUSH EYES WITH WATER FOR 15 TO 20 SECONDS. REMOVE CONTAMINATED CLOTHING AND WASH AFFECTED SKIN WITH SOAP AND WATER. SEEK MEDICAL ATTENTION.

(1) Remove cover plate filler plug on Tool 6906. Fill reservoir 1/2 to 3/4 full of fresh flushing solution. Flushing solvents are petroleum based solutions generally used to clean automatic transmission components. **DO NOT** use solvents containing acids, water, gasoline, or any other corrosive liquids.

(2) Reinstall filler plug on Tool 6906.

(3) Verify pump power switch is turned OFF. Connect red alligator clip to positive (+) battery post. Connect black (-) alligator clip to a good ground.

NOTE: When flushing transmission cooler and lines, ALWAYS reverse flush.

(4) Connect the BLUE pressure line to the OUTLET (From) cooler line.

(5) Connect the CLEAR return line to the INLET (To) cooler line

(6) Turn pump ON for two to three minutes to flush cooler and lines.

(7) Turn pump OFF.

(8) Disconnect CLEAR suction line from reservoir at cover plate. Disconnect CLEAR return line at cover plate, and place it in a drain pan.

(9) Turn pump ON for 30 seconds to purge flushing solution from cooler and lines. Turn pump OFF.

(10) Place CLEAR suction line into a one quart container of Mopar® ATF+4 (Automatic Transmission Fluid—Type 9602).

(11) Turn pump ON until all transmission fluid is removed from the one quart container and lines. This purges any residual cleaning solvent from the transmission cooler and lines. Turn pump OFF.

(12) Disconnect alligator clips from battery. Reconnect flusher lines to cover plate, and remove flushing adapters from cooler lines.

OIL PUMP VOLUME CHECK

Measuring oil pump output volume will determine if sufficient flow to the transmission oil cooler exists, and whether or not an internal transmission failure is present.

Verify that transmission fluid is at the proper level. Refer to Fluid Level and Condition in this Group. If adding fluid is necessary, fill to the proper level with Mopar® ATF+4 (Automatic Transmission Fluid—Type 9602). The following procedure is to check oil pump output volume:

(1) Disconnect the **To cooler** line at the oil cooler inlet and place a collecting container under the disconnected line (Fig. 39).

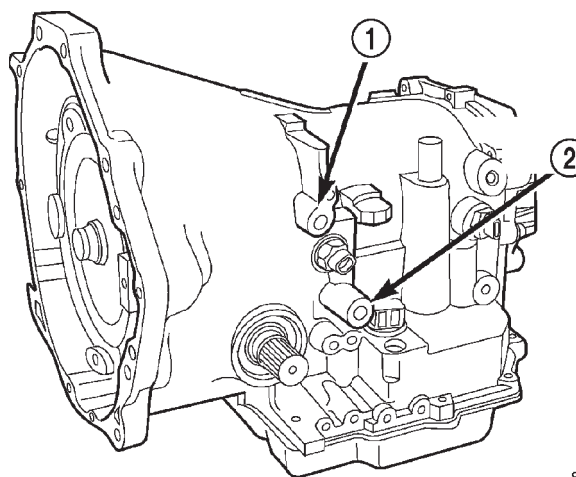

80ad0871

Fig. 39 Cooler Line Location

1 - FROM TRANSAXLE COOLER

2 - TO TRANSAXLE COOLER

CAUTION: With the fluid set at the proper level, fluid collection should not exceed (1) quart or internal damage to the transmission may occur.

(2) Start engine and run at **curb idle speed**, with the shift selector in neutral.

(3) If one quart of ATF is collected in 20 seconds or less, flow is within acceptable limits. If fluid flow is intermittent or it takes more than 20 seconds to collect one quart of ATF, refer to Hydraulic Pressure Tests in this Group.

(4) Inspect the cooler hose for damage. Replace if necessary.

(5) Connect the **To cooler** hose to the oil cooler inlet and torque clamp to 2 N·m (20 in. lbs.) torque.

(6) Refill the transaxle to proper level with Mopar® ATF+4 (Automatic Transmission Fluid—Type 9602).

SERVICE PROCEDURES (Continued)

TRANSAXLE QUICK LEARN PROCEDURE

The quick learn procedure requires the use of the DRB scan tool.

This program allows the electronic transaxle system to recalibrate itself. This will provide the best possible transaxle operation. The quick learn procedure should be performed if any of the following procedures are performed:

- Transaxle Assembly Replacement
- Transmission Control Module Replacement
- Solenoid/Pressure Switch Assembly Replacement
- Clutch Plate and/or Seal Replacement
- Valve Body Replacement or Recondition

To perform the Quick Learn Procedure, the following conditions must be met:

- The brakes must be applied
- The engine speed must be above 500 rpm
- The throttle angle (TPS) must be less than 3 degrees
- The shift lever position must stay until prompted to shift to overdrive
- The shift lever position must stay in overdrive after the Shift to Overdrive prompt until the DRB indicates the procedure is complete
- The calculated oil temperature must be above 60° and below 200°

(1) Plug the DRB scan tool into the data link connector. The connector is located under the instrument panel.

- (2) Go to the Transmission screen.
- (3) Go to the Miscellaneous screen.
- (4) Select Quick Learn Procedure. Follow the instructions of the DRB to perform the Quick Learn Procedure.

PINION FACTOR PROCEDURE

The vehicle speed readings for the speedometer are taken from the output speed sensor. The TCM must be calibrated to the different combinations of equipment available. Pinion Factor allows the technician to set the Transmission Control Module initial setting so that the speedometer readings will be correct.

Failure to perform this procedure will cause a No Speedometer Operation condition.

This procedure must be performed if the Transmission Control Module has been replaced.

To properly read or reset the Pinion Factor, it is necessary to use a DRB scan tool. Perform the following steps with the DRB scan tool to read or reset the Pinion Factor:

- (1) Plug the DRB scan tool into the data link connector located under the instrument panel.
- (2) Select the Transmission menu.
- (3) Select the Miscellaneous menu.
- (4) Select Pinion Factor. Then follow the instructions on the DRB scan tool screen.

REMOVAL AND INSTALLATION

GEARSHIFT CABLE-COLUMN SHIFT

REMOVAL

(1) Place vehicle in park, and turn ignition key to the "LOCK" position (Fig. 40).

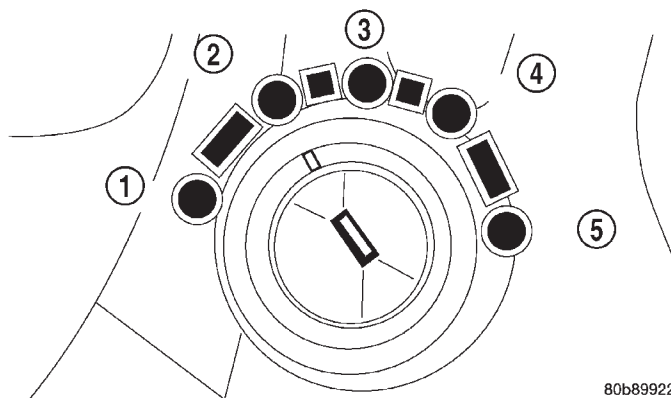

Fig. 40 Ignition Key/Switch Position

- 1 - ACC
- 2 - LOCK
- 3 - OFF
- 4 - ON/RUN
- 5 - START

(2) Remove under panel silencer/duct assembly (Fig. 41).

(3) Remove column cover screws (Fig. 42).

(4) Tilt column down and remove upper half of column cover (Fig. 43).

(5) Tilt the column to the uppermost position and remove the tilt lever (Fig. 44).

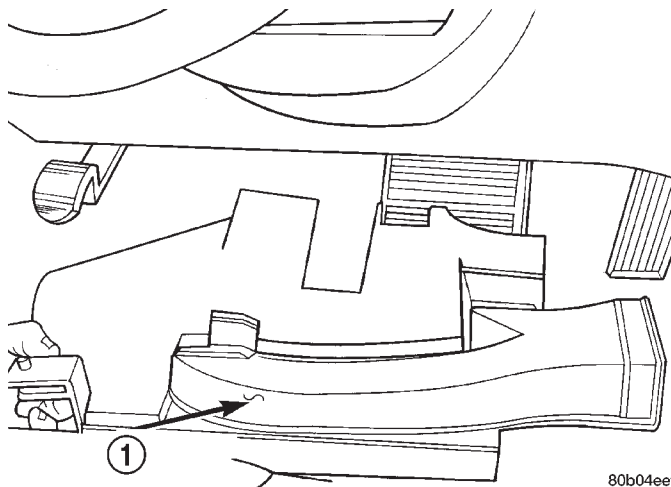

Fig. 41 Panel Removal/Installation

- 1 - SILENCER/DUCT ASSEMBLY

REMOVAL AND INSTALLATION (Continued)

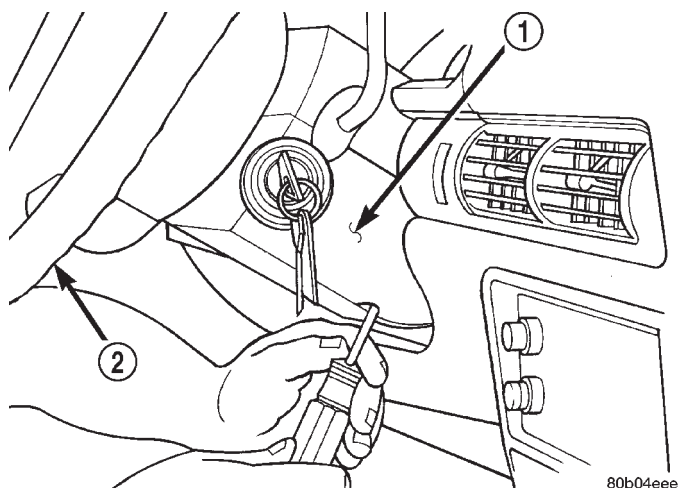

Fig. 42 Lower Column Cover Screw Removal/Installation

- 1 - LOWER COLUMN COVER
- 2 - STEERING WHEEL

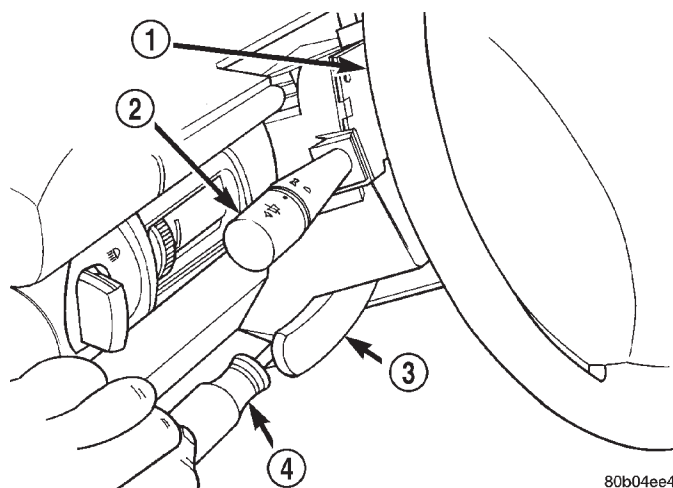

Fig. 44 Tilt Lever Screw Removal/Installation

- 1 - STEERING WHEEL
- 2 - TURN SIGNAL LEVER
- 3 - TILT LEVER
- 4 - SCREWDRIVER

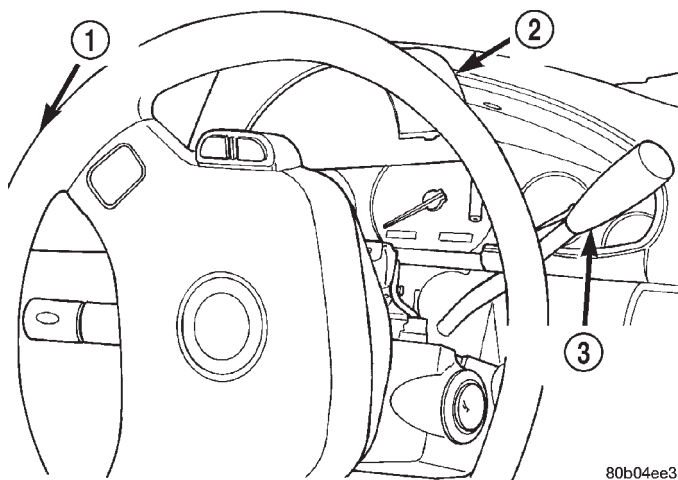

Fig. 43 Upper Column Removal/Installation

- 1 - STEERING WHEEL
- 2 - UPPER COLUMN COVER
- 3 - GEAR SHIFT HANDLE

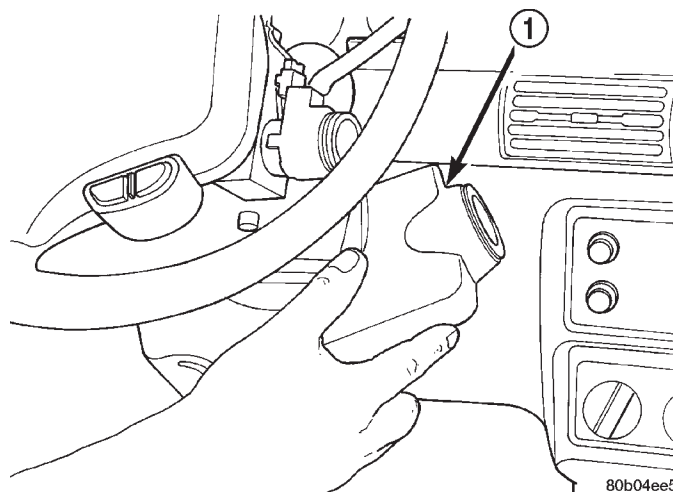

Fig. 45 Lower Column Cover Removal/Installation

- 1 - LOWER COLUMN COVER

(6) Remove the ignition key and remove lower column cover (Fig. 45).

(7) Remove cable from shift pin (Fig. 46).

(8) Remove cable retainer clip from shift cable conduit bracket (Fig. 46).

CAUTION: Column must be tilted fully upward to remove cable retainer clip.

(9) Raise hood. From inside the engine compartment, remove the gear shift cable from the cable bracket (Fig. 47).

(10) Unseat the cable grommet from the firewall (Fig. 49) and pull the shift cable from the interior of the vehicle.

(11) Raise vehicle on hoist and unbolt fill tube bracket. Rotate fill tube to gain access to the integrated shift cable clamp.

(12) Disconnect cable from routing bracket as shown in (Fig. 48).

(13) Remove shift cable retaining nut and slide cable assy. off of mounting stud (Fig. 49).

(14) Disconnect shifter cable from shift lever assembly at transaxle (Fig. 49).

(15) Remove cable from vehicle.

REMOVAL AND INSTALLATION (Continued)

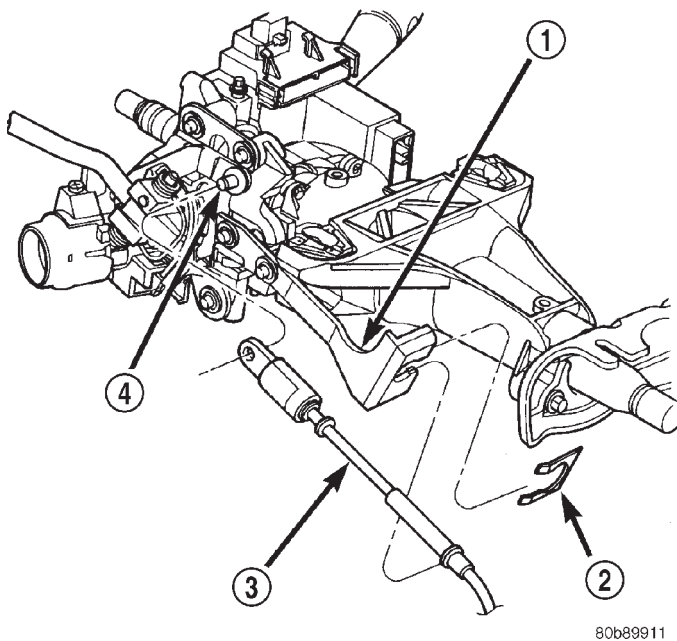

Fig. 46 Column Gear Shift Cable—Removal/Installation

- 1 - CONDUIT BRACKET
- 2 - RETAINER CLIP
- 3 - GEARSHIFT CABLE
- 4 - SHIFT PIN

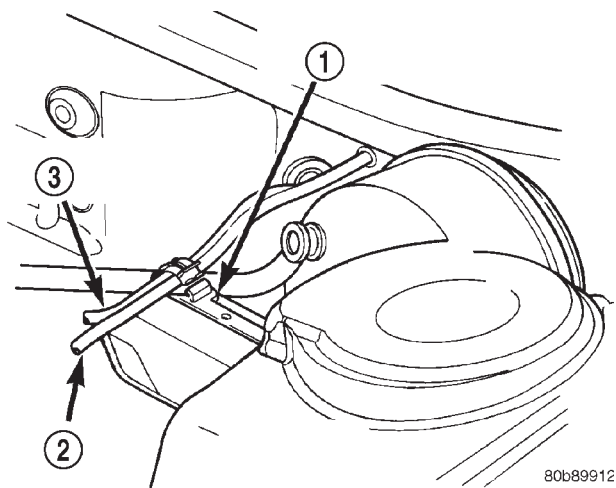

Fig. 47 Throttle/Gearshift Cable Bracket

- 1 - CABLE BRACKET
- 2 - GEARSHIFT CABLE
- 3 - THROTTLE CABLE

INSTALLATION

(1) Make sure transaxle shift lever is in "park." This is the most rearward position. Verify park sprag is fully engaged by rotating either a tire or an axle shaft.

(2) Position cable in vehicle and connect cable end to the transaxle shift lever (Fig. 49).

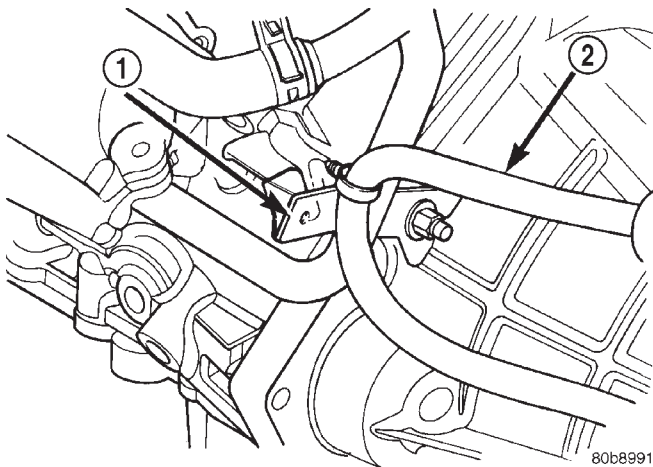

Fig. 48 Cable Routing Bracket—(3.2L/3.5L Shown/2.7L Similar)

- 1 - BRACKET
- 2 - CABLE

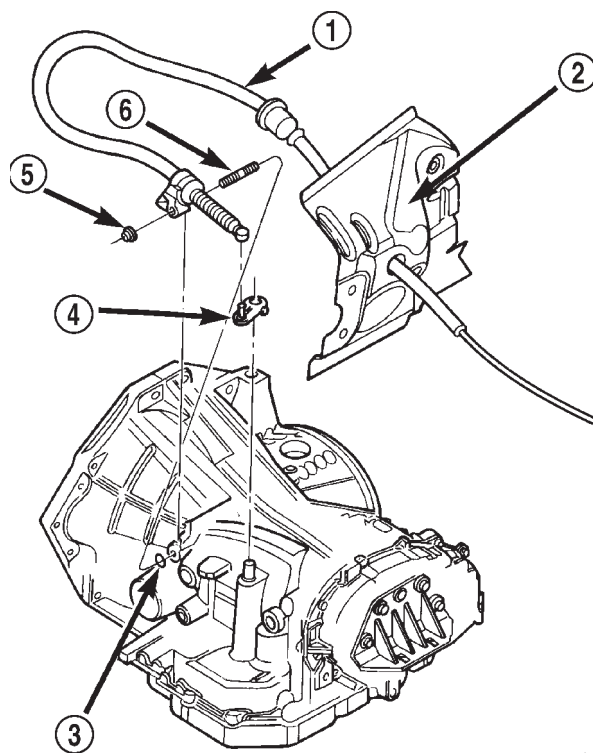

Fig. 49 Gearshift Cable Removal

- 1 - CABLE
- 2 - FIREWALL
- 3 - WASHER
- 4 - SHIFT LEVER
- 5 - NUT
- 6 - STUD

(3) Verify that the washer (Fig. 49) is still in place on the cable mounting stud. Install cable to transaxle and tighten nut to 28 N·m (250 in. lbs.).

REMOVAL AND INSTALLATION (Continued)

(4) Rotate fill tube to original location. Install and tighten fill tube bracket bolt.

(5) Install cable "push pin" into bracket as shown in (Fig. 48).

(6) Route transaxle shift cable through hole in dash panel (Fig. 49) (Fig. 50).

(7) Lubricate cable grommet with a synthetic lubricant (or equivalent) and secure to hole. Verify that it is seated by pulling outward on cable.

(8) Install cable into throttle/gearshift cable bracket (Fig. 47).

(9) Inside the vehicle, route the gearshift between the left a/c duct and the left lower heat duct (Fig. 50) and up to the steering column.

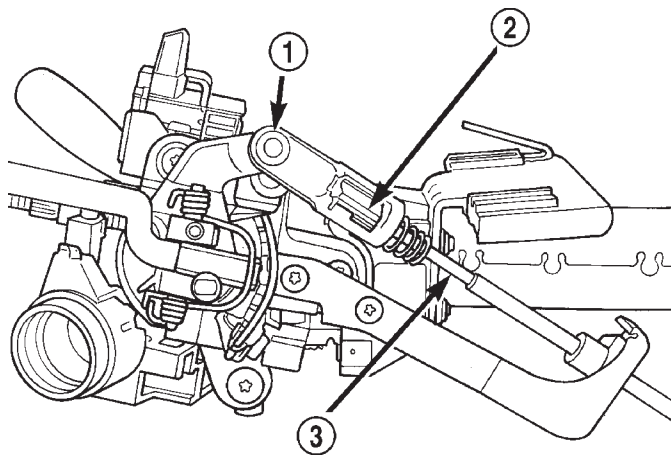

80b04eea

Fig. 51 Shift Cable Adjuster Lock

- 1 - SHIFTER PIN
- 2 - CABLE ADJUSTER LOCK
- 3 - SHIFT CABLE

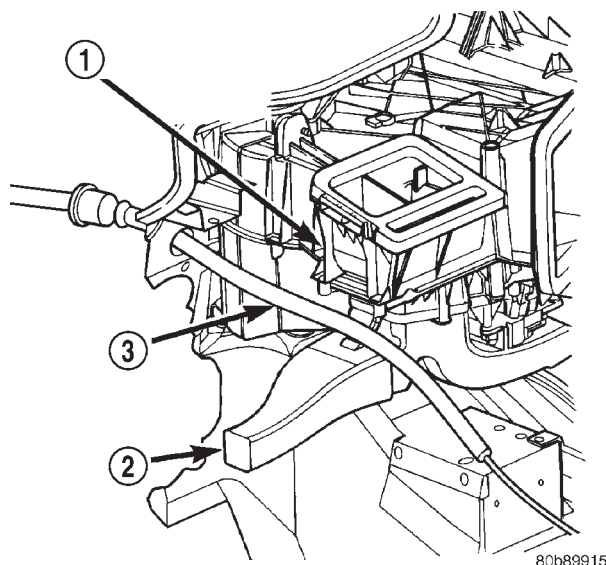

80b99915

Fig. 50 Shift Cable Routing

- 1 - LH A/C DUCT OUTLET
- 2 - LH LOWER HEAT DUCT
- 3 - GEARSHIFT CABLE

(10) Tilt steering column all the way up and make sure shift lever is still in "park."

(11) Connect transaxle shift cable to shift cable conduit bracket and secure with new clip (Fig. 46).

(12) Attach shift cable to attaching stud (pin) (Fig. 46) by snapping into place.

(13) Move the steering column to full tilt downward. Put the column shifter in park with key removed.

(14) Adjust cable by rotating the adjuster into lock position (Fig. 51). The adjuster will click when lock is fully adjusted.

(15) Reinstall upper and lower steering column shrouds (Fig. 43) (Fig. 45). Then install underpanel silencer/duct.

(16) Check shifter for proper operation. It should operate smoothly without binding. The engine starter should crank in park or Neutral positions only.

GEARSHIFT CABLE-FLOOR SHIFT

REMOVAL

(1) Using suitable size allen wrench, remove the shift handle retaining screw (Fig. 52).

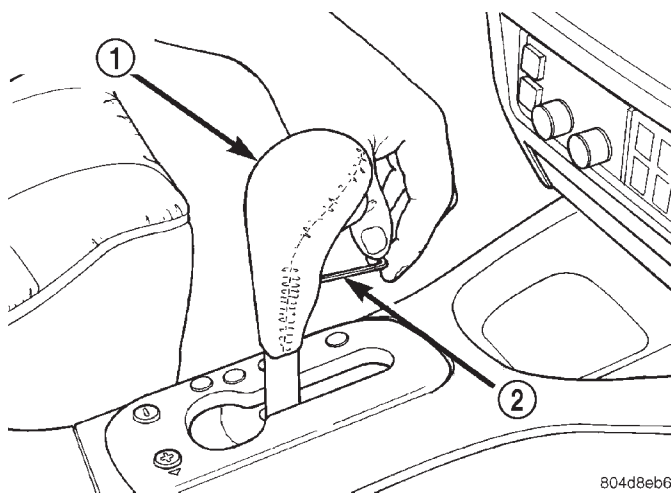

804d8eb6

Fig. 52 Shift Handle Retaining Screw

- 1 - GEARSHIFT KNOB
- 2 - HEX WRENCH

- (2) Remove shift handle from shifter assy.
- (3) Remove console bezel from vehicle.
- (4) Loosen nut on shift cable adjust lever (Fig. 53).
- (5) Remove retaining clip from shift cable conduit bracket (Fig. 54).
- (6) Disconnect shifter cable from cable attach stud (pin) (Fig. 54).
- (7) Remove cable from center console routing. Leave flat on floor for ease of removal.

REMOVAL AND INSTALLATION (Continued)

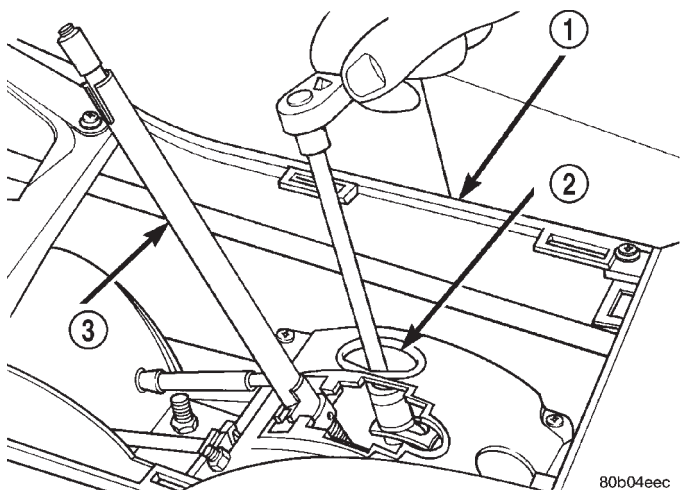

Fig. 53 Shift Cable Adjust Lever Nut

- 1 - CONSOLE
- 2 - ACCESS HOLE
- 3 - SHIFTER HANDLE

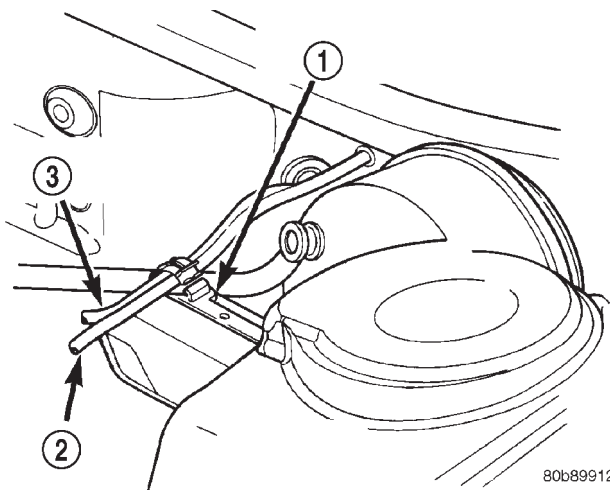

Fig. 55 Throttle/Gearshift Cable Bracket

- 1 - CABLE BRACKET
- 2 - GEARSHIFT CABLE
- 3 - THROTTLE CABLE

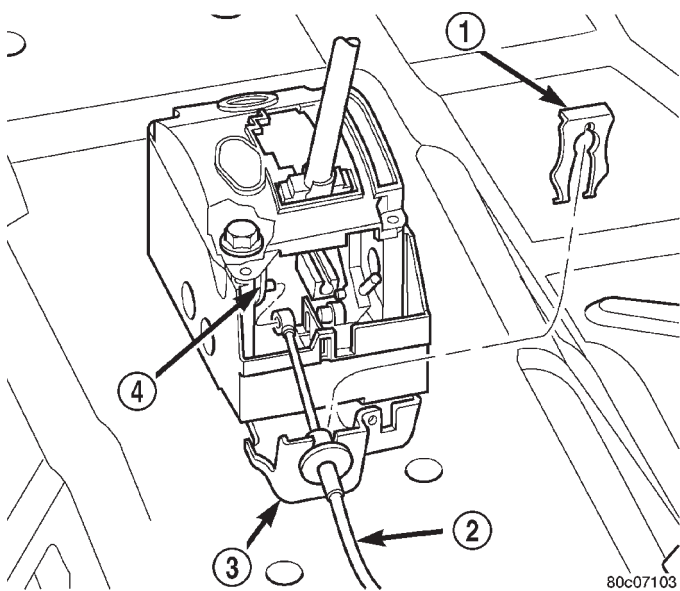

Fig. 54 Floor Gearshift Cable Removal/Installation

- 1 - CUP
- 2 - CABLE
- 3 - CONDUIT BRACKET
- 4 - PIN

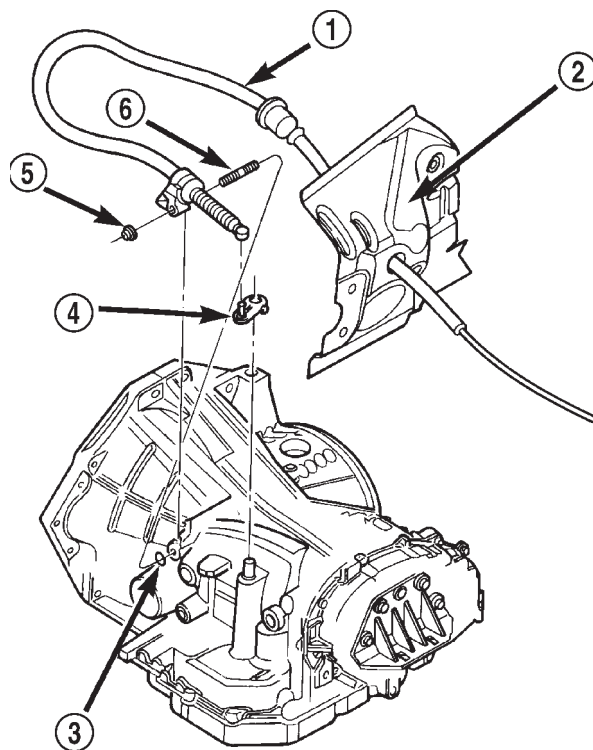

Fig. 56 Gearshift Cable Removal/Installation

- 1 - CABLE
- 2 - FIREWALL
- 3 - WASHER
- 4 - SHIFT LEVER
- 5 - NUT
- 6 - STUD

(8) Raise hood. Remove gearshift cable from throttle/gearshift cable bracket (Fig. 55)

(9) Unseat cable grommet at firewall and remove cable from interior of vehicle (Fig. 56).

(10) Raise vehicle on hoist and disconnect fill tube bracket from transaxle. Rotate fill tube to gain access to shift cable clamp.

(11) Remove cable from routing bracket (Fig. 57).

(12) Remove cable-to-transaxle nut and slide cable off of stud (Fig. 56).

(13) Disconnect shifter cable from shift lever assembly at transaxle (Fig. 56).

(14) Remove cable from underneath vehicle.

REMOVAL AND INSTALLATION (Continued)

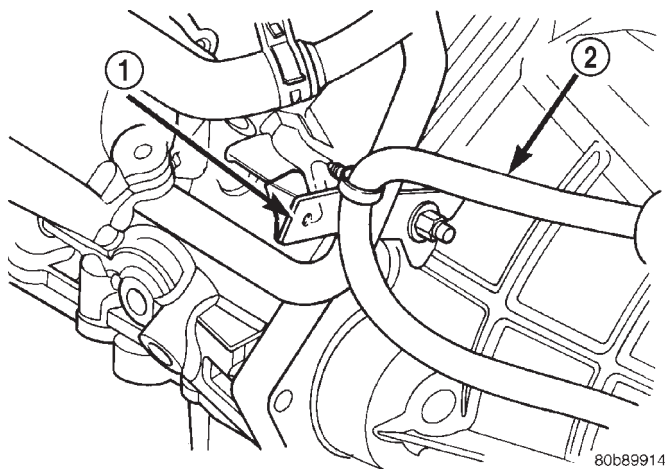

Fig. 57 Gearshift Cable Routing Bracket

- 1 - BRACKET
- 2 - CABLE

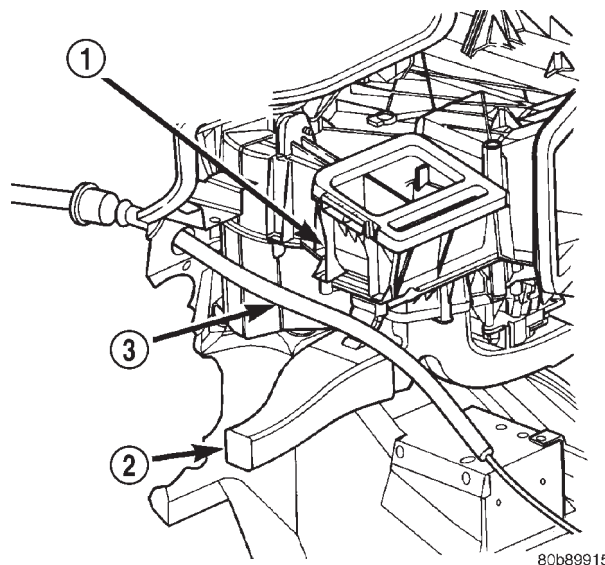

Fig. 58 Gearshift Cable Routing

- 1 - LH A/C DUCT OUTLET
- 2 - LH LOWER HEAT DUCT
- 3 - GEARSHIFT CABLE

INSTALLATION

(1) Make sure transaxle shift lever is in "Park." This is the most rearward position. Verify park sprag is fully engaged by rotating either a tire or an axle shaft.

(2) Position cable in vehicle and connect cable end to the transaxle shift lever (Fig. 56).

(3) Verify that the washer (Fig. 56) is still in place on the cable mounting stud. Install cable to transaxle and tighten nut to 28 N·m (250 in. lbs.).

(4) Rotate fill tube to original location. Install and tighten fill tube bracket bolt.

(5) Install cable "push pin" into bracket as shown in (Fig. 55).

(6) Route transaxle shift cable through hole in dash panel (Fig. 56) (Fig. 58).

(7) Lubricate cable grommet with a synthetic lubricant (or equivalent) and secure to hole. Verify that it is seated by gently pulling outward on cable.

(8) Install cable into throttle/gearshift cable bracket (Fig. 55).

(9) Inside the vehicle, route the gearshift cable between the left a/c duct and the left lower heat duct (Fig. 58) and towards the gearshift mechanism.

(10) Route cable through hole in shifter conduit bracket and attach to cable attaching shift pin by snapping into place (Fig. 54).

(11) Install a new clip onto the cable at the shifter bracket (Fig. 54).

(12) Tighten the adjuster nut (Fig. 53).

(13) Reinstall console bezel and shifter handle. Firmly press the shifter handle downward and tighten the screw (Fig. 52).

(14) Check shifter for proper operation. It should operate smoothly without binding. The starter should crank in Park or Neutral only.

FLOOR SHIFTER

REMOVAL

(1) Remove shifter handle and console bezel.

(2) If equipped with Autostick, disconnect the Autostick switch connector.

(3) Loosen adjuster nut on shifter adjuster (Fig. 59).

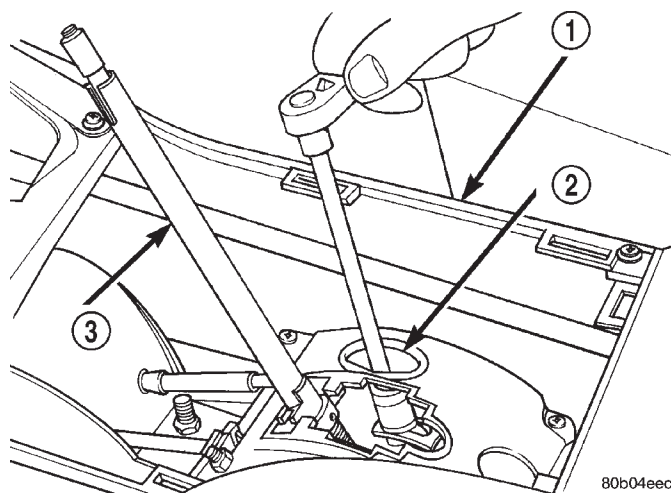

Fig. 59 Shift Cable Adjust Lever Nut

- 1 - CONSOLE
- 2 - ACCESS HOLE
- 3 - SHIFTER HANDLE

(4) Disconnect shifter cable from shift pin (Fig. 60) and disconnect cable from shifter assembly bracket.

REMOVAL AND INSTALLATION (Continued)

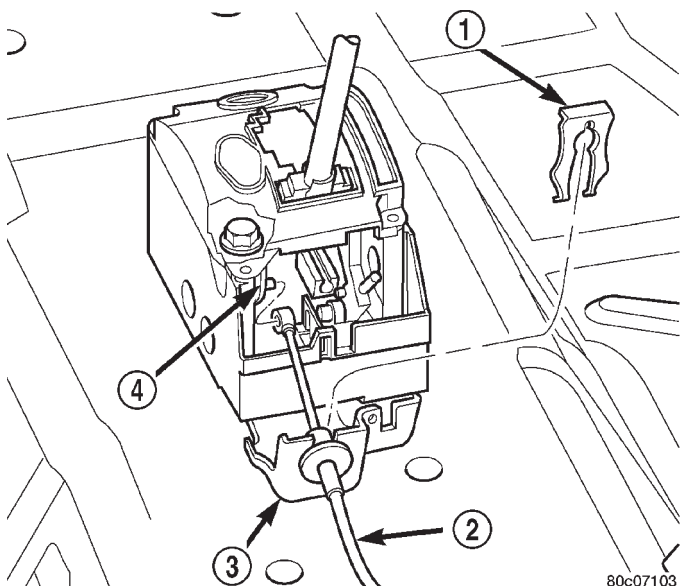

Fig. 60 Shift Cable Removal/Installation

- 1 - CUP
- 2 - CABLE
- 3 - CONDUIT BRACKET
- 4 - PIN

(5) Disconnect interlock cable from shifter base slot (Fig. 61). Be careful not to break tab on interlock cable conduit end fitting.

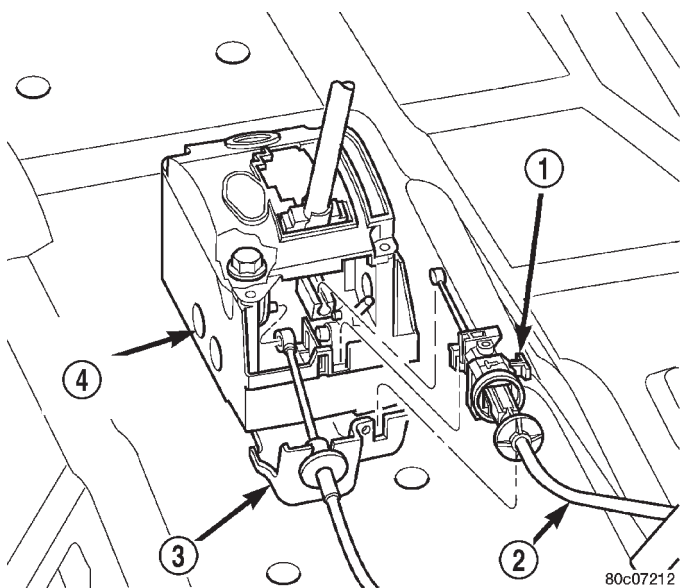

Fig. 61 Interlock Cable Removal/Installation

- 1 - LOCKING CLIP
- 2 - INTERLOCK CABLE
- 3 - BRACKET
- 4 - SHIFTER ASSEMBLY

(6) Remove the five floor pan attaching nuts from the shifter base and shift cable bracket (Fig. 62).
 (7) Remove shifter assembly from vehicle (Fig. 62).

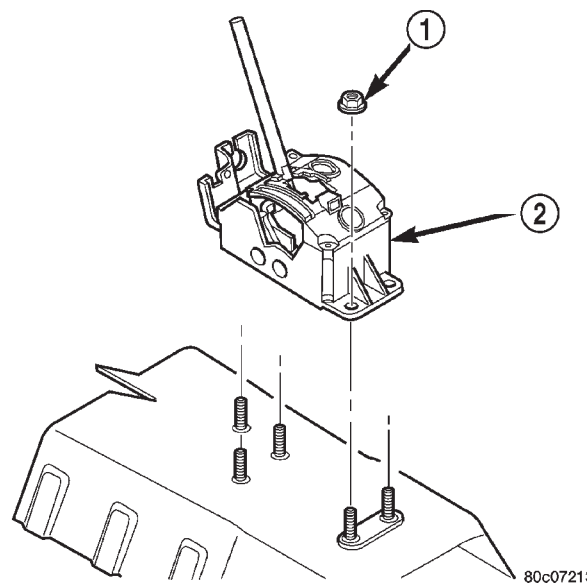

Fig. 62 Shifter Assembly Removal/Installation

- 1 - NUT
- 2 - SHIFTER ASSEMBLY

INSTALLATION

- (1) Install shifter assembly (Fig. 62).
- (2) Install five shifter/cable bracket to floor pan nuts and tighten to 31 N·m (23 ft. lbs.).
- (3) Make sure shift lever and transaxle are in "Park."

CAUTION: Park sprag must be engaged when adjusting linkage. Rock vehicle back and forth to ensure that park sprag is fully engaged.

- (4) With the ignition in the lock position, attach shift cable eyelet to shift pin (Fig. 60).
- (5) Install shift cable to shifter assembly bracket (Fig. 60).
- (6) Slip interlock cable core wire into interlock adjustment lever groove (Fig. 61). Make sure the interlock cable slug is seated in the groove.
- (7) Slip interlock cable conduit end fitting into bracket and snap into place (Fig. 61).
- (8) If equipped with Autostick, connect the Auto-stick connector.
- (9) Adjust gear shift and interlock cables.

NOTE: Gearshift and interlock cables **MUST** be adjusted. Refer to the Adjustments section in this Group for the correct procedures.

INTERLOCK CASSETTE

The interlock cassette slides into the housing behind the lock cylinder (Fig. 63). The cable at the rear of the cassette attaches to a locking arm on the shifter mechanism. **The column shift interlock**

REMOVAL AND INSTALLATION (Continued)

system is only adjusted after installing a new cassette. It can't be adjusted more than once. If the system operates incorrectly, install and adjust a new interlock cassette.

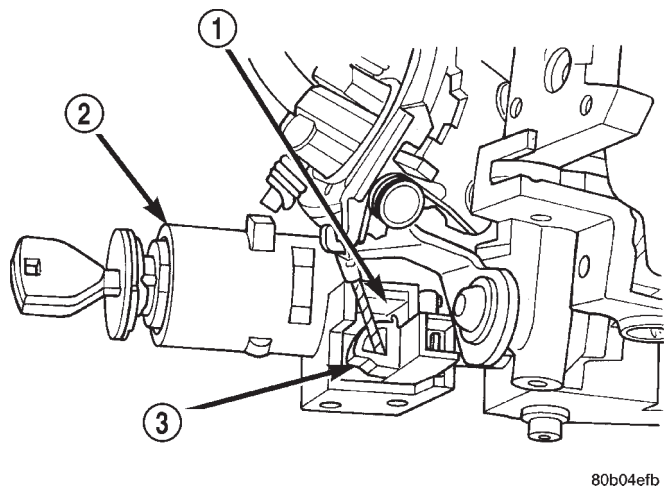

Fig. 63 Ignition Interlock Cassette—Column Shift

- 1 - RELEASE TAB
- 2 - LOCK CYLINDER
- 3 - INTERLOCK CASSETTE

REMOVAL

- (1) Depress the tab on the top of the cassette.
- (2) Slide the interlock cassette out of the housing.
- (3) Remove the cable from the locking arm on the shifter mechanism.

INSTALLATION

- (1) Ensure the latch rotates freely on the shifter gate (Fig. 64).

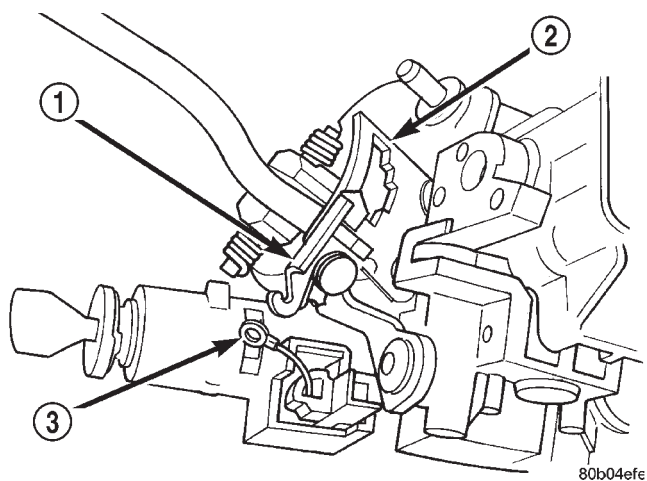

Fig. 64 Latch and Shifter Gate

- 1 - LATCH
- 2 - SHIFTER GATE
- 3 - CASSETTE CABLE

- (2) With the shifter in Park and the key removed, install the cable over the hook on locking arm of the shifter mechanism.

- (3) Slide the cassette into the housing until it locks in place.

- (4) To adjust the interlock system, push the adjustment tab in until it stops (Fig. 65). The adjustment tab will click as it moves into position. Ensure the tab is fully depressed.

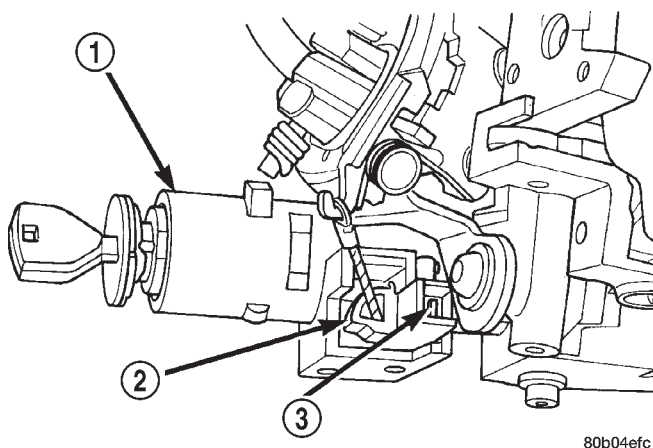

Fig. 65 Ignition Interlock Adjustment Tab—Column Shift

- 1 - LOCK CYLINDER HOUSING
- 2 - INTERLOCK CASSETTE
- 3 - ADJUSTMENT TAB

BRAKE TRANSMISSION SHIFT INTERLOCK SOLENOID (COLUMN)

NOTE: The following procedure applies to vehicles with steering column mounted shift levers only.

REMOVAL

- (1) Remove the fuse panel cover from the left end of the instrument panel (Fig. 66).
- (2) Remove the two screws behind the fuse panel cover attaching the lower instrument panel cover to the instrument panel (Fig. 67).
- (3) Remove the lower instrument panel cover. The lower instrument panel cover is attached by retaining clips along the top and right edge.

NOTE: The upper shroud on this steering column is retained to the steering column by a snap fit to the lower shroud. When removing the upper shroud from the steering column lower shroud, DO NOT use a hard or sharp tool. This will damage the shrouds. If a tool must be used, use a soft tool such as a trim stick.

REMOVAL AND INSTALLATION (Continued)

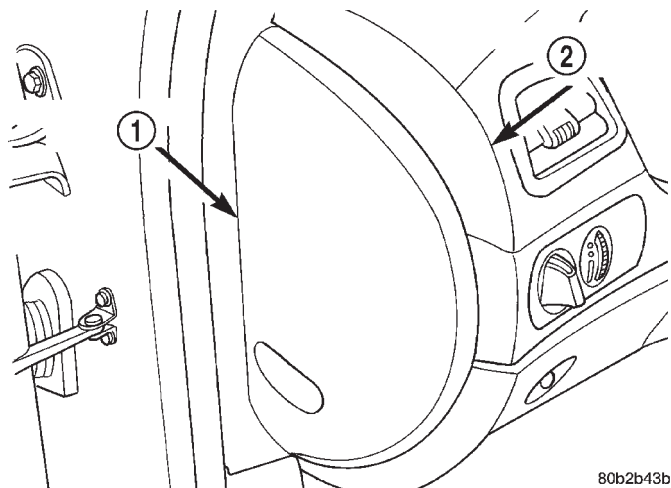

Fig. 66 Fuse Panel Cover

- 1 - FUSE PANEL COVER
- 2 - INSTRUMENT PANEL

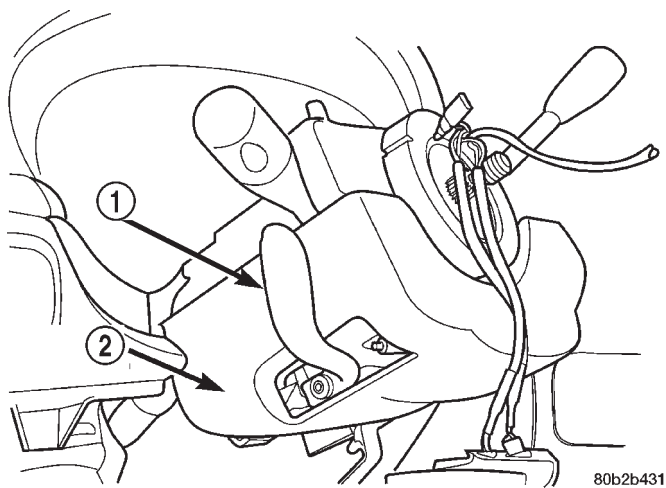

Fig. 68 Tilt Lever

- 1 - TILT LEVER
- 2 - LOWER SHROUD

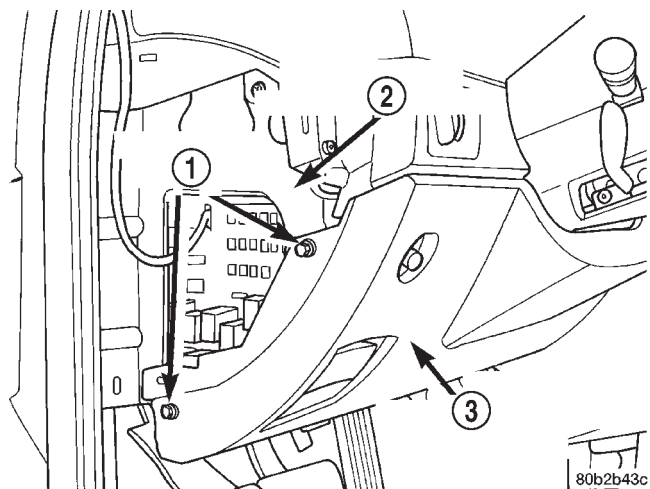

Fig. 67 Lower Instrument Panel Cover Mounting Screws

- 1 - MOUNTING SCREWS
- 2 - INSTRUMENT PANEL BRACKET
- 3 - LOWER INSTRUMENT PANEL COVER

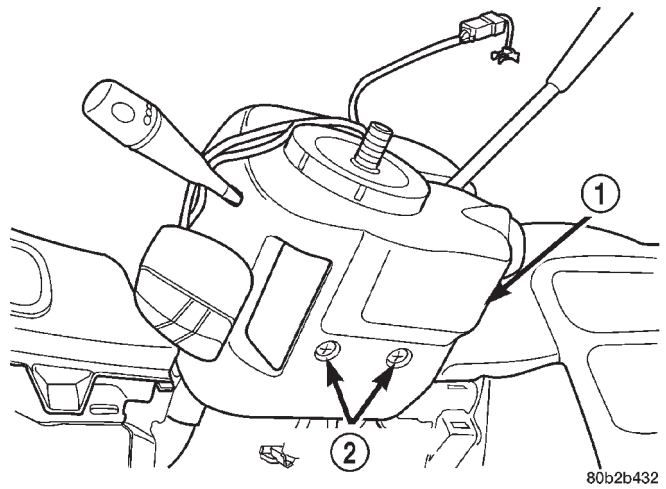

Fig. 69 Lower Shroud Attaching Screws

- 1 - LOWER SHROUD
- 2 - MOUNTING SCREWS

(4) Remove the steering column upper shroud from the steering column using the following procedure: First, on the right seam between the upper and lower shrouds, push in on seam at the forward end. When the upper shroud unsnaps, pull the upper shroud upward away from the lower. Repeat this procedure on the opposite side of the column to release the upper shroud from the lower. Remove the upper shroud from the steering column.

(5) Remove the tilt lever (Fig. 68) from the steering column.

(6) Remove the 2 screws attaching the lower shroud to the steering column (Fig. 69). Remove the lower shroud from the steering column.

(7) Disconnect the wiring harness connector from the brake transmission shift interlock (BTISI) solenoid (Fig. 70).

(8) Remove the retainer clip from the end of the BTISI solenoid (Fig. 71).

(9) Slide the BTISI solenoid straight off the shift lever mounting stud.

INSTALLATION

(1) Align the flat inside the brake transmission shift interlock (BTISI) solenoid (Fig. 72) with the flat on the shift lever mounting stud.

(2) Slide the solenoid completely onto the shift lever mounting stud aligning the plastic guide formed into the solenoid housing with the flange on the shift lever mechanism bracket (Fig. 73).

REMOVAL AND INSTALLATION (Continued)

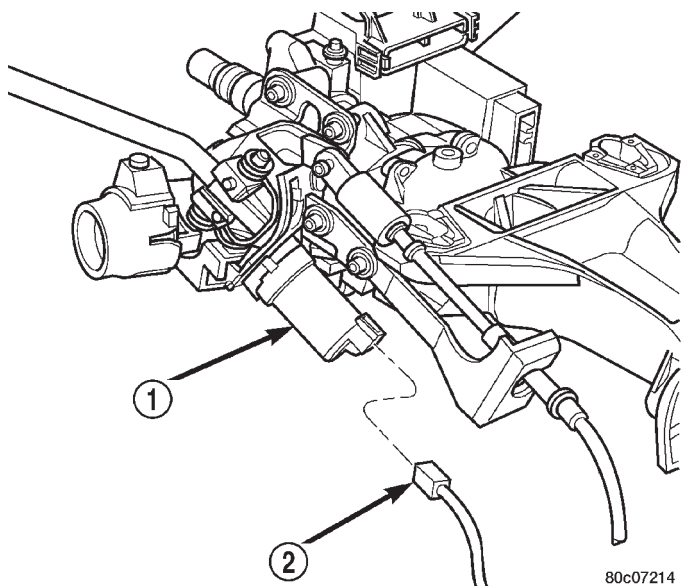

Fig. 70 Solenoid Connector

- 1 - BTSI SOLENOID
- 2 - CONNECTOR

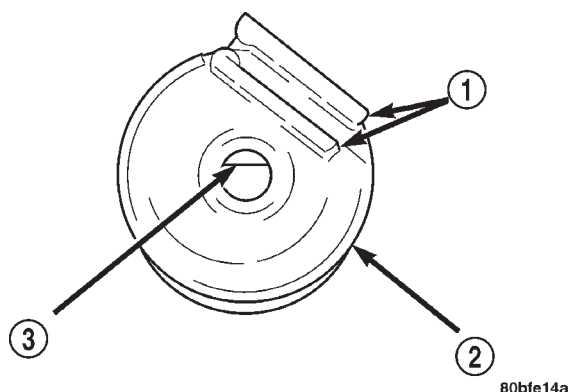

Fig. 72 Flat Inside BTSI Solenoid

- 1 - GUIDES
- 2 - SOLENOID
- 3 - FLAT

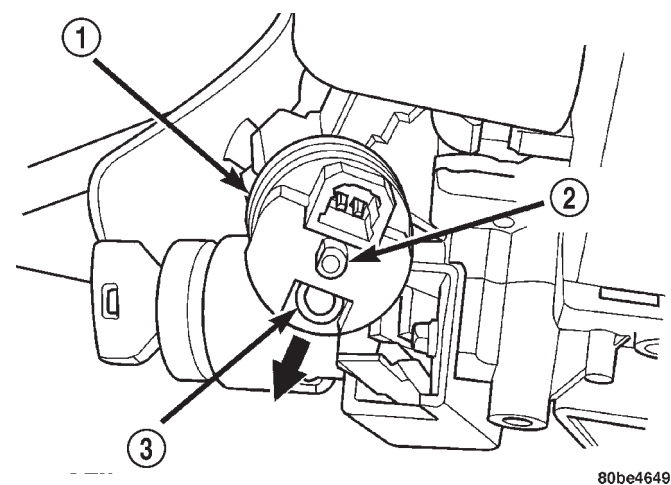

Fig. 71 Solenoid Retainer Clip Removal

- 1 - SOLENOID
- 2 - MOUNTING STUD
- 3 - RETAINER CLIP

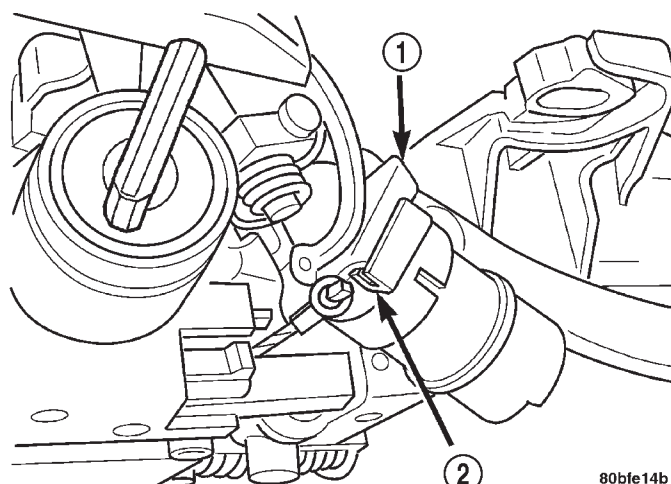

Fig. 73 Guide And Flange Alignment

- 1 - BRACKET FLANGE
- 2 - GUIDE

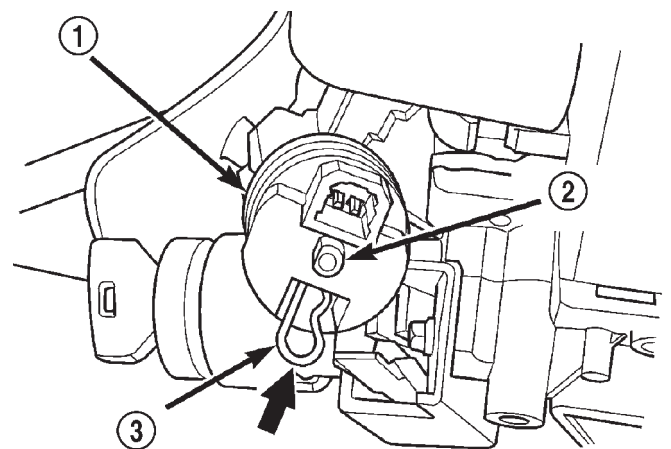

Fig. 74 Solenoid Retainer Clip Installation

- 1 - SOLENOID
- 2 - MOUNTING STUD
- 3 - RETAINER CLIP

(3) Install the retainer clip until it snaps into place in the slot cut into the shift lever mounting stud (Fig. 74).

(4) Verify the BTSI solenoid is locked in place and will not slide off the mounting stud.

(5) Connect the wiring harness connector to the BTSI solenoid.

(6) Verify the BTSI is operating properly. With the ignition on (engine not running) and the parking brake applied, try shifting the transmission shift lever out of the PARK position with and without the brake pedal being applied. The shift lever should

REMOVAL AND INSTALLATION (Continued)

only shift out of PARK with the brake pedal being depressed.

(7) Install the lower shroud (Fig. 69) on the steering column. Install and securely tighten the 2 screws attaching the lower shroud to the steering column.

(8) Install the tilt lever (Fig. 68) on the steering column.

(9) Install the upper shroud on the steering column by snapping it onto the lower shroud.

(10) Install the lower instrument panel cover.

(11) Install the two screws behind the fuse panel cover attaching the lower instrument panel cover to the instrument panel (Fig. 67).

(12) Install the fuse panel cover on the left end of the instrument panel (Fig. 66).

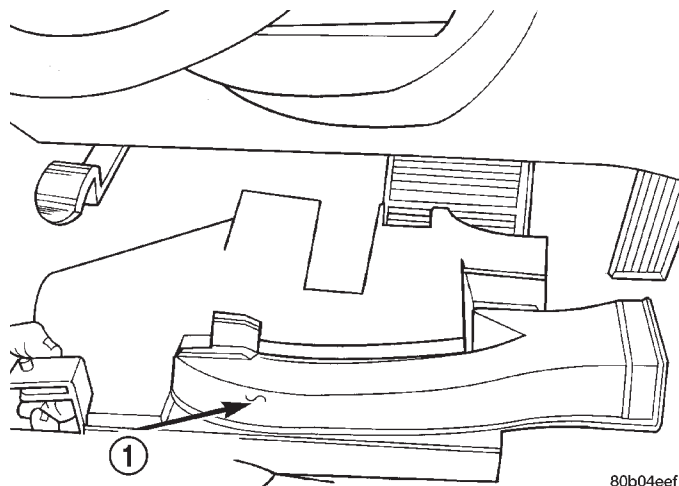

Fig. 76 Panel Removal/Installation

1 - SILENCER/DUCT ASSEMBLY

BRAKE/TRANSMISSION SHIFT INTERLOCK CABLE (FLOOR)

REMOVAL

(1) Using suitable size allen wrench, remove the gearshift knob retaining screw (Fig. 75).

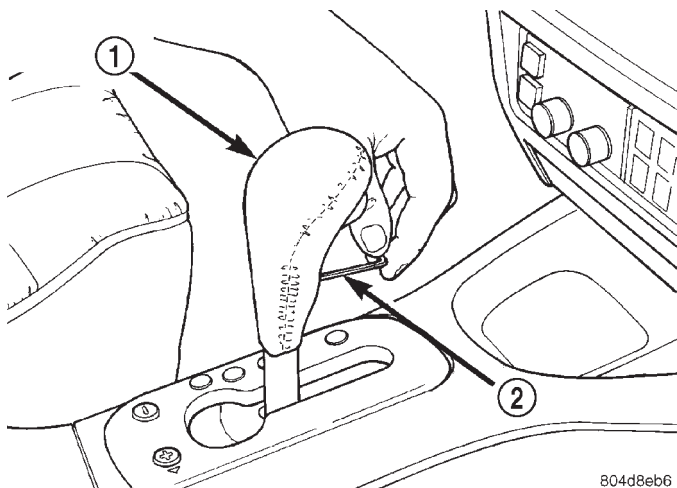

Fig. 75 Shift Handle Retaining Screw

1 - GEARSHIFT KNOB
2 - HEX WRENCH

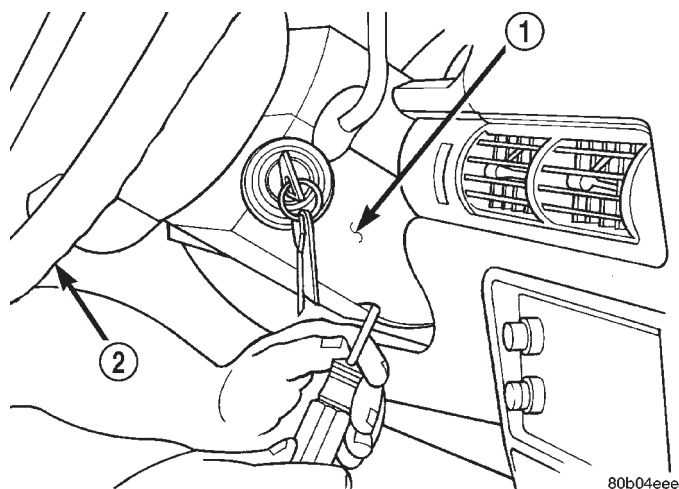

Fig. 77 Lower Column Cover Screw Removal/Installation

1 - LOWER COLUMN COVER
2 - STEERING WHEEL

- (2) Remove gearshift knob from shifter assy.
- (3) Remove console bezel from vehicle.
- (4) Remove under panel silencer/duct assembly (Fig. 76).
- (5) Remove column cover screws (Fig. 77).
- (6) Tilt column down and remove upper half of column cover (Fig. 78).
- (7) Tilt the column to the uppermost position and remove the tilt lever (Fig. 79).
- (8) Remove the ignition key and remove lower column cover (Fig. 80).
- (9) Remove the interlock cable from the shifter housing. Slide the cable out of the groove in the interlock lever (Fig. 81).

- (10) Disconnect the BTSI solenoid connector.
- (11) Depress the lock tab (Fig. 82) on the interlock cable and pull the cable out of the lock cylinder housing (Fig. 83).
- (12) Remove interlock cable. Note cable routing so it can be installed in the same manner.

INSTALLATION

- (1) Ensure ignition switch is in the "ON/RUN" position (Fig. 84).
- (2) Route the interlock cable into position as previously removed.
- (3) Slide the steering column end of the interlock cable into the lock cylinder housing until it snaps into place (Fig. 83).
- (4) Connect BTSI solenoid connector.

REMOVAL AND INSTALLATION (Continued)

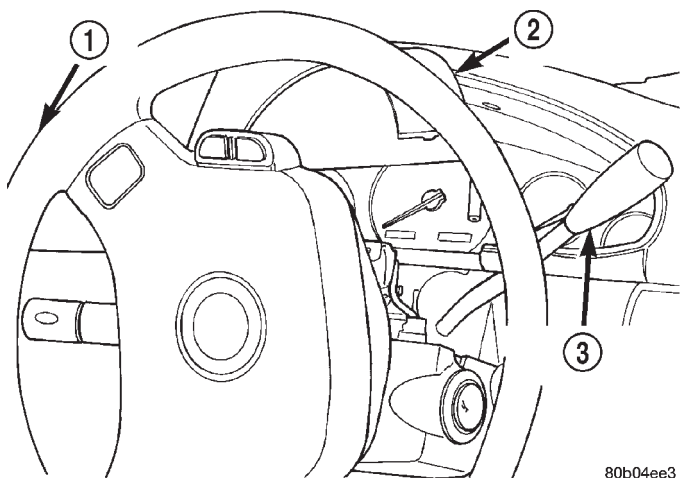

80b04ee3

Fig. 78 Upper Column Removal/Installation

- 1 - STEERING WHEEL
- 2 - UPPER COLUMN COVER
- 3 - GEAR SHIFT HANDLE

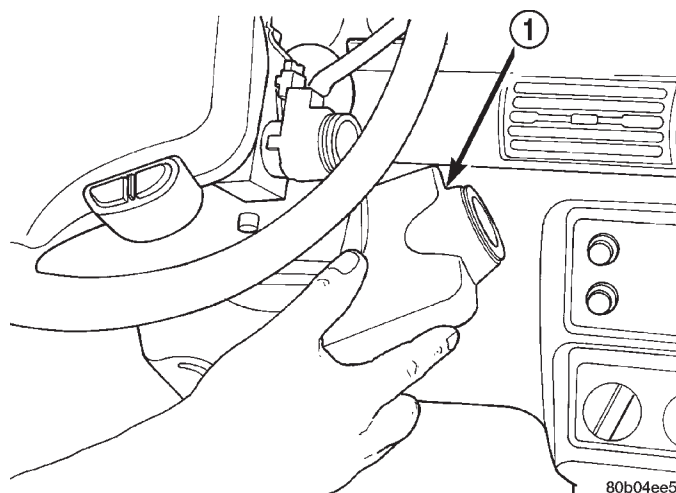

80b04ee5

Fig. 80 Lower Column Cover Removal/Installation

- 1 - LOWER COLUMN COVER

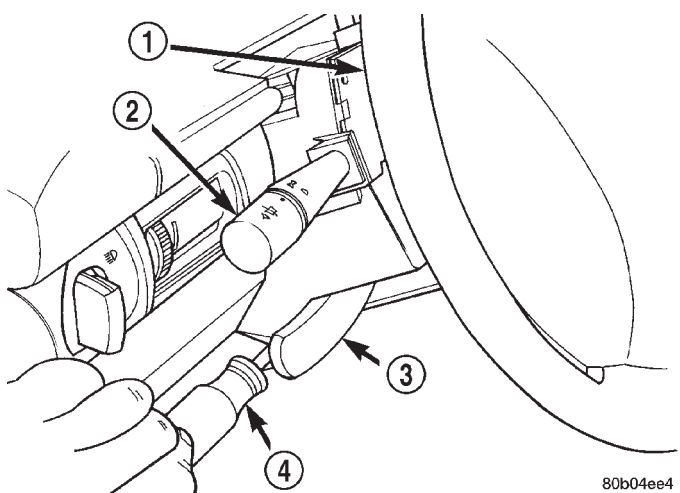

80b04ee4

Fig. 79 Tilt Lever Screw Removal/Installation

- 1 - STEERING WHEEL
- 2 - TURN SIGNAL LEVER
- 3 - TILT LEVER
- 4 - SCREWDRIVER

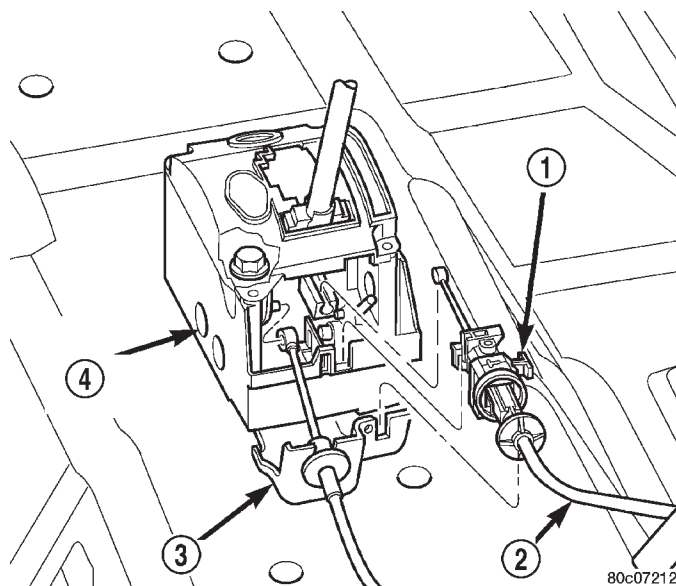

80c07212

Fig. 81 Interlock Cable at Shifter

- 1 - LOCKING CLIP
- 2 - INTERLOCK CABLE
- 3 - BRACKET
- 4 - SHIFTER ASSEMBLY

(5) Turn the ignition key to the "LOCK" position (Fig. 84).

(6) Put the shifter in the PARK position.

(7) Slide the interlock cable core wire into the groove on the lever (Fig. 81). Ensure the cable end seats in the groove.

(8) Slip the cable into the shifter housing until it snaps into place.

(9) Ensure the shift lever remains in PARK. Move the ignition key to the "LOCK" position and remove the key. Tilt the steering column to the full UP position.

(10) If the interlock cable is being replaced, remove the lock pin. Allow the cable to adjust itself to the correct position. Tighten the locking clip (Fig. 81) by pushing it down.

(11) If the interlock cable is being re-used, the lock pin will not exist. Free adjustment by pulling outward on locking clip. The cable will index itself to the correct position. Tighten the locking clip by pushing it down.

(12) Insert the ignition key and verify the ignition interlock adjustment/operation. Refer to Description

REMOVAL AND INSTALLATION (Continued)

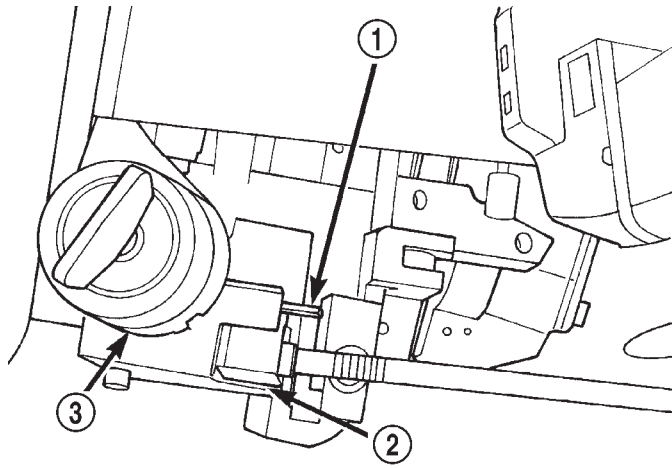

80b04ef9

Fig. 82 Interlock Cable Locking Tab

- 1 - TAB
- 2 - INTERLOCK CABLE
- 3 - LOCK CYLINDER HOUSING

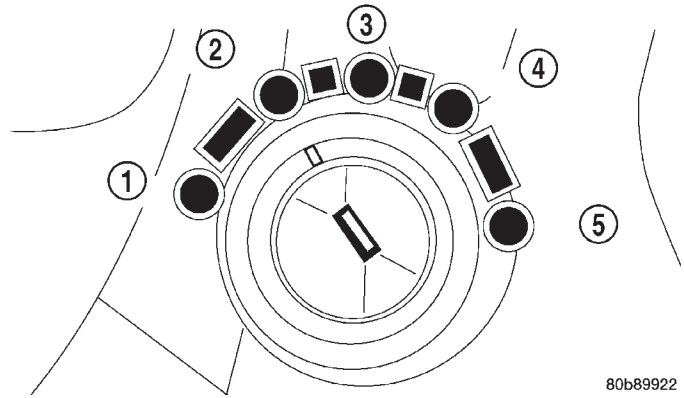

80b89922

Fig. 84 Ignition Key/Switch Positions

- 1 - ACC
- 2 - LOCK
- 3 - OFF
- 4 - ON/RUN
- 5 - START

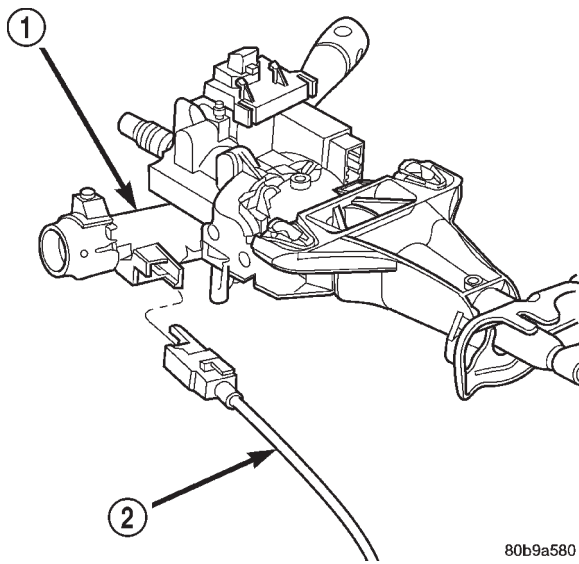

80b9a580

Fig. 83 Interlock Cable Removal/Installation

- 1 - LOCK CYLINDER HOUSING
- 2 - INTERLOCK CABLE

and Operation to determine intended operation. If adjustment is necessary, refer to Adjustments.

(13) Install the bezel on the shifter console.

(14) Install gearshift knob (Fig. 75).

(15) Install upper and lower covers from the steering column (Fig. 77).

(16) Install tilt lever (Fig. 79).

(17) Install the lower silencer panel (Fig. 76).

TRANSMISSION RANGE SENSOR

REMOVAL

- (1) Disconnect the TRS connector.

- (2) Remove valve body assembly from vehicle. Refer to Valve Body removal and Installation in this group.

- (3) Remove the manual shaft seal (Fig. 85).

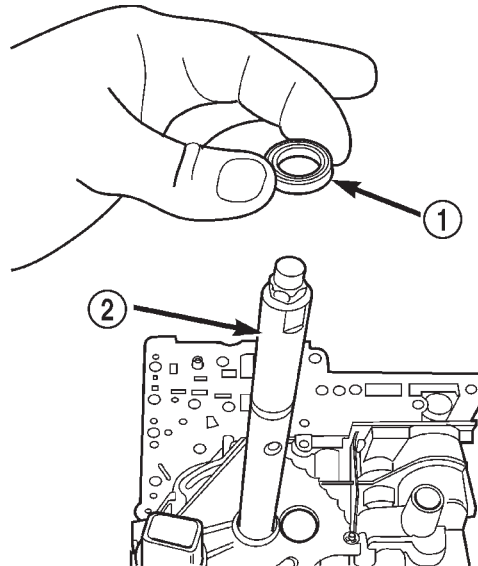

80be4707

Fig. 85 Manual Shaft Seal—Typical

- 1 - SEAL
- 2 - MANUAL SHAFT

- (4) Remove manual shaft/TRS retaining screw (Fig. 86).

- (5) Slide TRS off of manual valve shaft.

INSTALLATION

- (1) Install the TRS to the manual shaft. Make sure TRS locating pin rests in manual valve bore slot.

REMOVAL AND INSTALLATION (Continued)

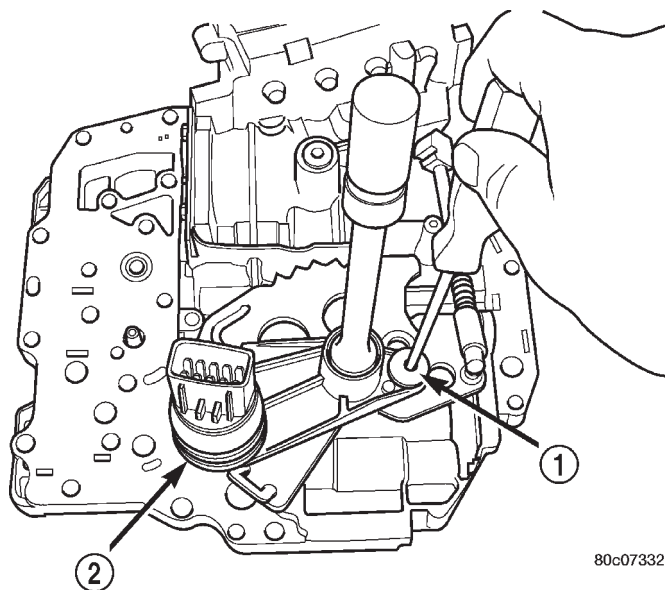

Fig. 86 Manual Shaft Retaining Screw

- 1 - SCREW
- 2 - TRS

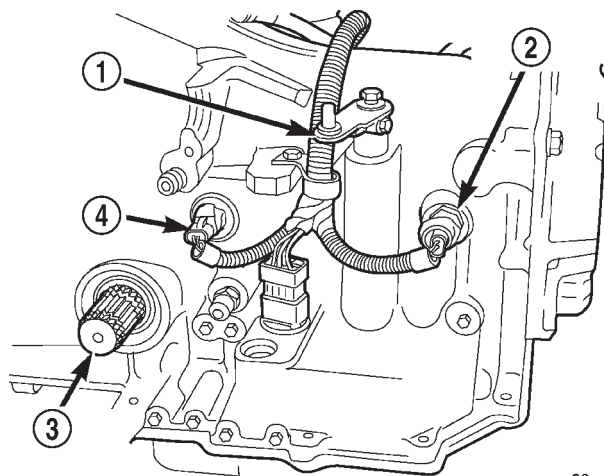

Fig. 87 Speed Sensor/Connector Location

- 1 - MANUAL SHIFT LEVER
- 2 - OUTPUT SPEED SENSOR
- 3 - LONG STUB SHAFT
- 4 - INPUT SPEED SENSOR

(2) Install the TRS/manual shaft retaining screw and torque to 5 N·m (45 in. lbs.) torque (Fig. 86).

(3) Install the manual shaft seal (Fig. 85).

(4) Install valve body to transaxle. Refer to Valve Body Removal and Installation in this group.

INPUT SPEED SENSOR

CAUTION: When disconnecting speed sensor connector, be sure that the weather seal does not fall off or remain in the old sensor.

NOTE: The input speed sensor is not interchangeable with the output speed sensor.

REMOVAL

(1) Disconnect the input speed sensor connector (Fig. 87).

(2) Unscrew and remove the input speed sensor.

(3) Inspect the speed sensor o-ring and replace if necessary (Fig. 88).

INSTALLATION

(1) Verify o-ring is installed into position (Fig. 88).

(2) Install and tighten input speed sensor to 27 N·m (20 ft. lbs.) torque.

(3) Connect speed sensor connector (Fig. 87).

(4) Connect battery negative cable.

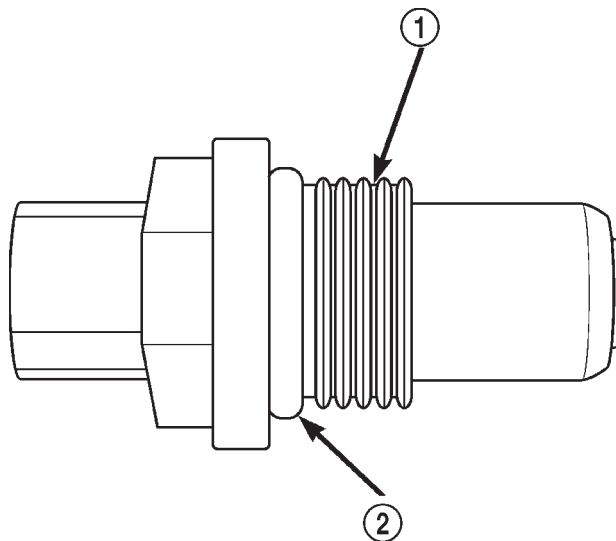

Fig. 88 O-Ring Location

- 1 - INPUT SPEED SENSOR
- 2 - O-RING

OUTPUT SPEED SENSOR

CAUTION: When disconnecting speed sensor connector, be sure that the weather seal does not fall off or remain in the old sensor.

NOTE: The output speed sensor is not interchangeable with the input speed sensor.

REMOVAL AND INSTALLATION (Continued)

REMOVAL

(1) Disconnect the output speed sensor connector (Fig. 89).

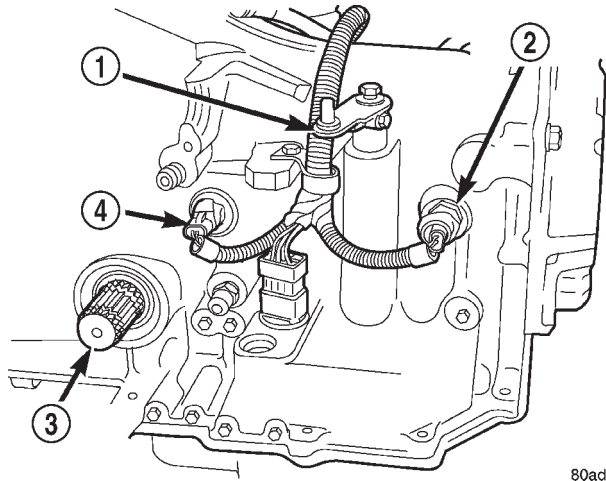

80ac8402

Fig. 89 Speed Sensor/Connector Location

- 1 - MANUAL SHIFT LEVER
- 2 - OUTPUT SPEED SENSOR
- 3 - LONG STUB SHAFT
- 4 - INPUT SPEED SENSOR

(2) Unscrew and remove the output speed sensor.
 (3) Inspect the speed sensor o-ring and replace if necessary (Fig. 90).

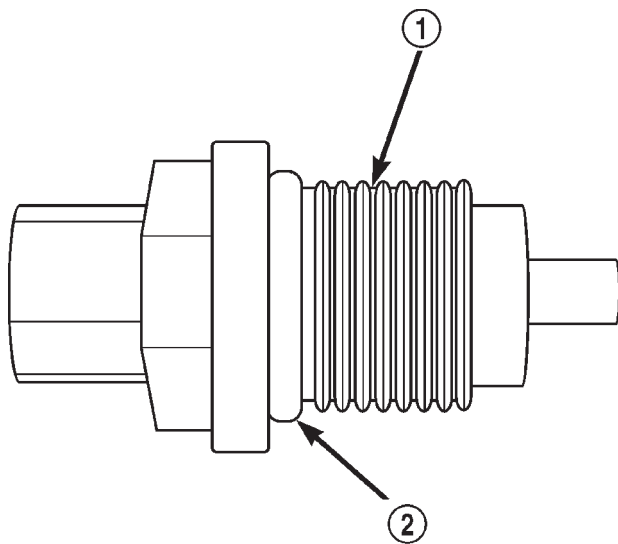

80be46b9

Fig. 90 O-Ring Location

- 1 - OUTPUT SPEED SENSOR
- 2 - O-RING

INSTALLATION

(1) Verify o-ring is installed into position (Fig. 90).
 (2) Install and tighten output speed sensor to 27 N·m (20 ft. lbs.) torque.

(3) Connect speed sensor connector (Fig. 89).
 (4) Connect battery negative cable.

TRANSMISSION CONTROL MODULE

REMOVAL

(1) Remove speed control servo (three fasteners).
 (2) Remove windshield washer reservoir fill tube fastener.
 (3) Remove one nut and screw holding transmission control module bracket to vehicle.
 (4) Lift control module and bracket to gain access to 60-way connector.
 (5) Loosen 60-way connector retaining screw, located in the center of the 60 way connector. Then disconnect the 60-way connector on transmission control module.
 (6) Remove transmission control module mounting screws and lift module from vehicle (Fig. 91).

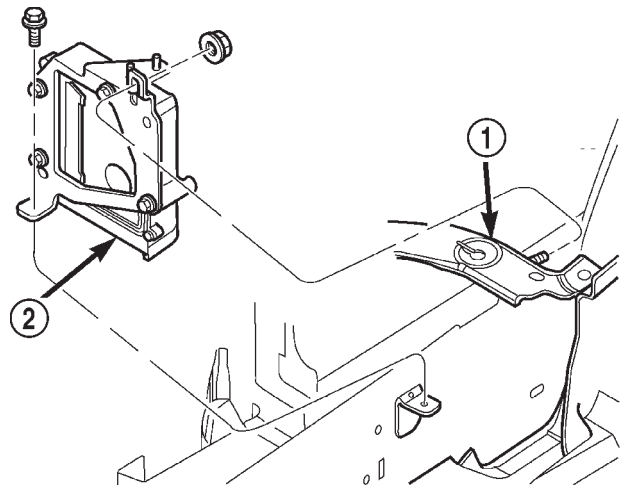

80c07331

**Fig. 91 Transmission Control Module (TCM)—
Removal/Installation**

- 1 - RADIATOR UPPER SUPPORT
- 2 - TCM

INSTALLATION

(1) Install transmission control module and tighten mounting screws.
 (2) Install 60 way connector. Tighten 60-way retaining screw to 4 N·m (35 in. lbs.).
 (3) Install one nut and screw holding transmission control module bracket to vehicle (Fig. 91). Torque screw to 6 N·m (45 in. lbs.). Torque nut to 12 N·m (107 in. lbs.) torque.
 (4) Install windshield washer reservoir fill tube fastener.
 (5) Install speed control servo (three fasteners).

REMOVAL AND INSTALLATION (Continued)

TRANSMISSION CONTROL RELAY

REMOVAL

- (1) Open hood and locate power distribution center in the engine compartment.
- (2) Remove power distribution center plastic cover.
- (3) Pull relay out of power distribution center (Fig. 92).

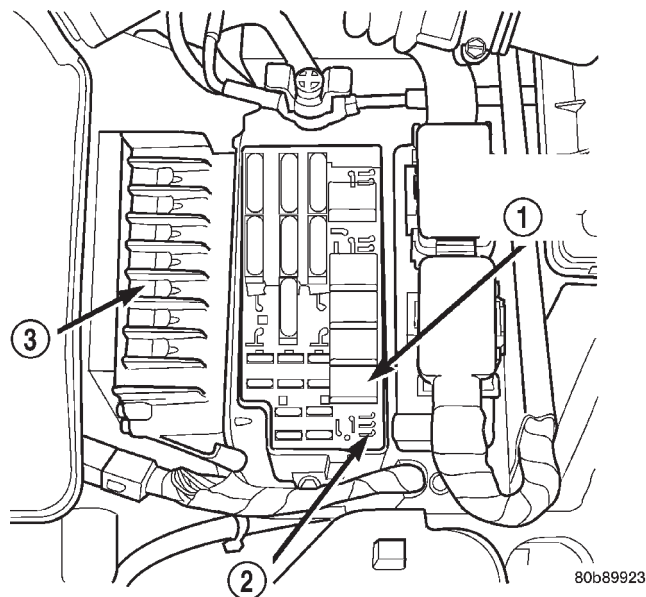
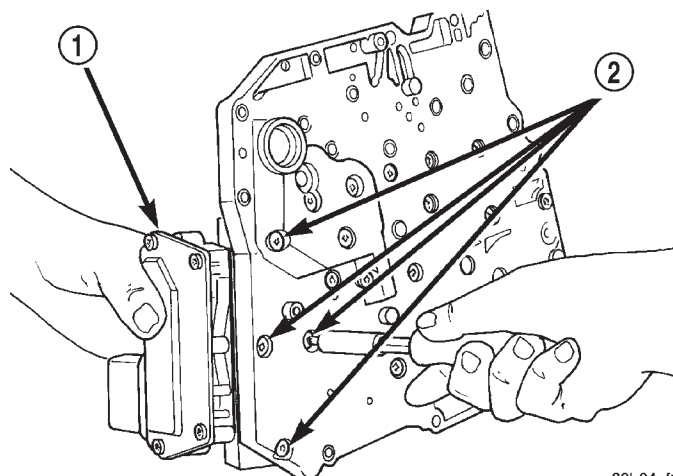

Fig. 92 Transmission Control Relay Location

- 1 - TRANSMISSION CONTROL RELAY
- 2 - PDC
- 3 - TCM



80b04ef1

Fig. 93 Solenoid Retaining Screws

- 1 - SOLENOID PACK
- 2 - SOLENOID RETAINING SCREWS

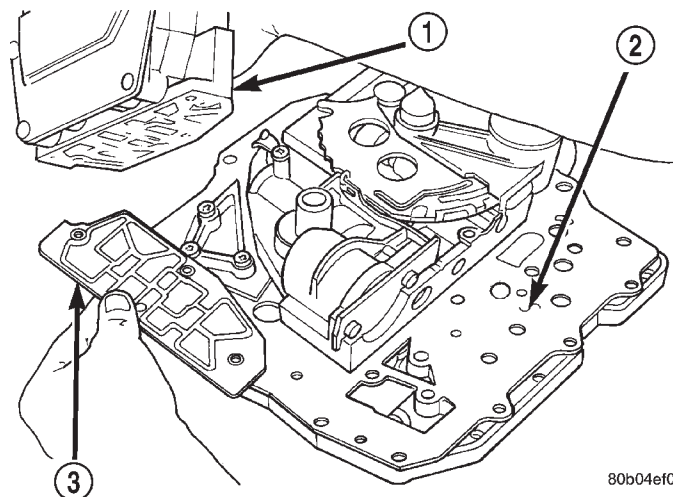

80b04ef0

Fig. 94 Solenoid/Pressure Switch Assembly and Screen

- 1 - SOLENOID PACK
- 2 - VALVE BODY
- 3 - SCREEN

INSTALLATION

- (1) To install, reverse removal procedure.

SOLENOID/PRESSURE SWITCH ASSEMBLY

REMOVAL

- (1) Raise vehicle on hoist.
- (2) Remove valve body assembly from transaxle. Refer to Valve Body Removal and Installation in this section for procedure.
- (3) Remove Solenoid/Pressure Switch Assembly retaining screws from solenoid (Fig. 93).
- (4) Remove Solenoid/Pressure Switch Assembly and screen from valve body (Fig. 94).

INSTALLATION

- (1) Install Solenoid/Pressure Switch Assembly and screen to the separator and transfer plates (Fig. 94).
- (2) Install and tighten retaining screws (Fig. 93) to 6 N·m (53 in. lbs.) torque.
- (3) Install valve body. Refer to Valve Body Removal and Installation.

VALVE BODY

REMOVAL

- (1) Disconnect the TRS wiring connector. The solenoid wiring connector can remain attached to the case.
- (2) Disconnect the shift cable from the shift lever (at the transaxle).
- (3) Move the shift lever clockwise as far as it will go. This should be one position past the L position. Then remove the shift lever.
- (4) Remove transaxle pan bolts (Fig. 95).

REMOVAL AND INSTALLATION (Continued)

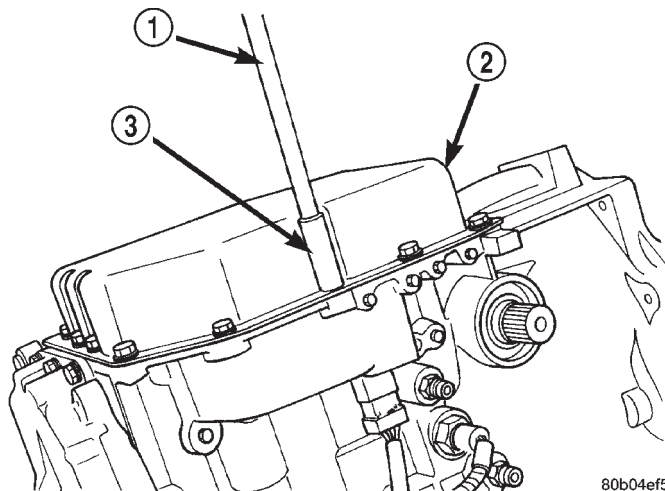

Fig. 95 Transaxle Oil Pan Bolts

- 1 - EXTENSION
- 2 - TRANSAXLE OIL PAN
- 3 - SOCKET

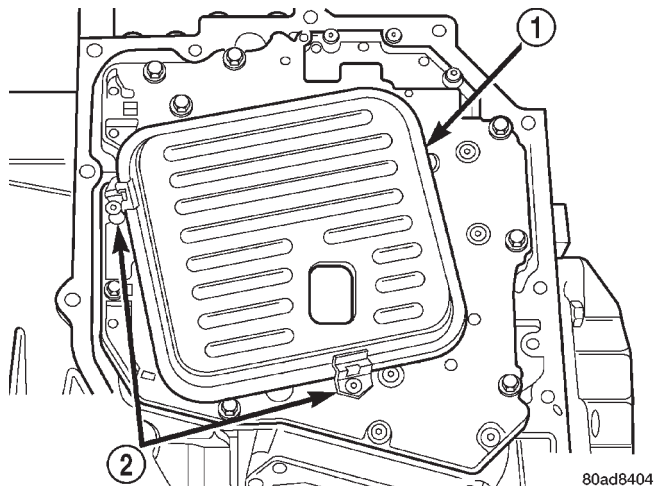

Fig. 97 Transaxle Oil Filter

- 1 - TRANSAXLE FILTER
- 2 - FILTER RETAINING CLIPS

(5) Remove transaxle oil pan (Fig. 96). When reinstalling oil pan be sure that pan flange is clean and oil free. Apply a 1/8 inch bead of Mopar Silicone Sealer onto oil pan flange before installing.

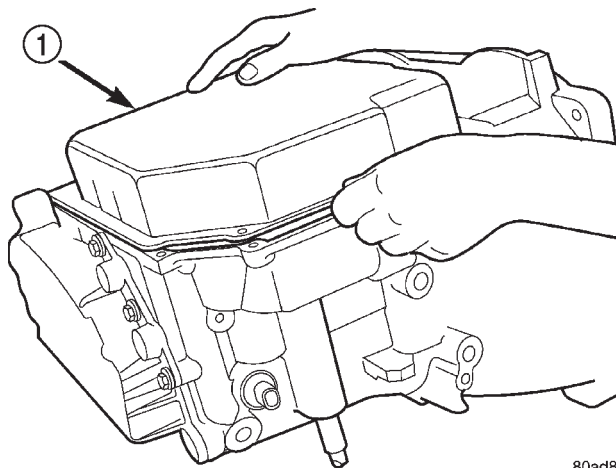

Fig. 96 Transaxle Oil Pan

- 1 - TRANSAXLE OIL PAN

(6) Remove oil filter from valve body (Fig. 97). It is held in place by two clips.

CAUTION: The 42LE transaxle oil filter is not interchangeable with the 41TE transaxle filter. Installation of a 41TE oil filter in a 42LE may cause transaxle damage.

(7) Remove valve body bolts-to-case (Fig. 98).

(8) Carefully remove valve body assembly from transaxle (Fig. 99).

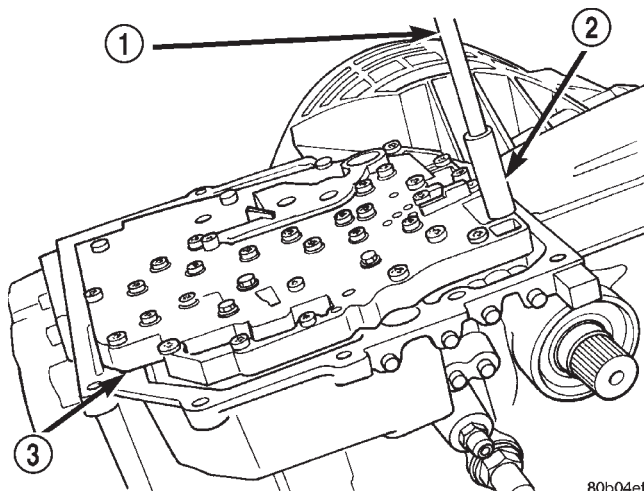

Fig. 98 Valve Body Bolts

- 1 - EXTENSION
- 2 - SOCKET
- 3 - VALVE BODY

CAUTION: The overdrive and underdrive accumulators and springs may fall out when removing the valve body.

INSTALLATION

(1) Install valve body into position and start bolts (Fig. 99).

(2) Torque valve body to transaxle case bolts (Fig. 98) to 12 N·m (105 in. lbs.) torque.

(3) Install transaxle oil filter (Fig. 97).

(4) Make sure oil pan and case rail are clean and dry. Install an 1/8" bead of RTV to the transaxle oil pan and install to case. Tighten bolts (Fig. 95) to 23 N·m (17 ft. lbs.).

REMOVAL AND INSTALLATION (Continued)

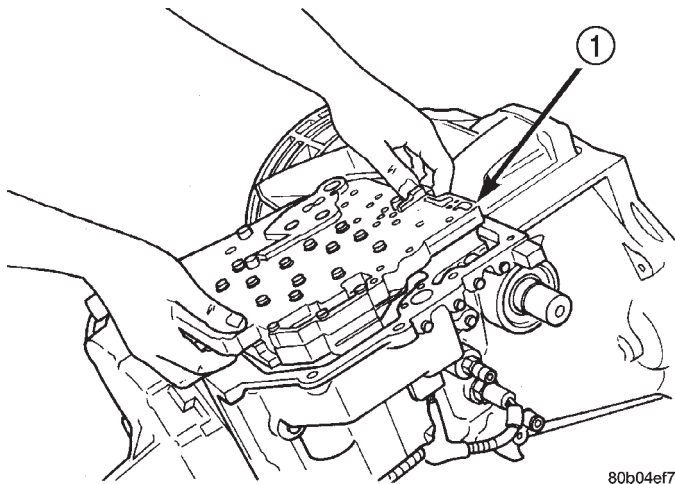

80b04ef7

Fig. 99 Valve Body From Transaxle

1 - VALVE BODY

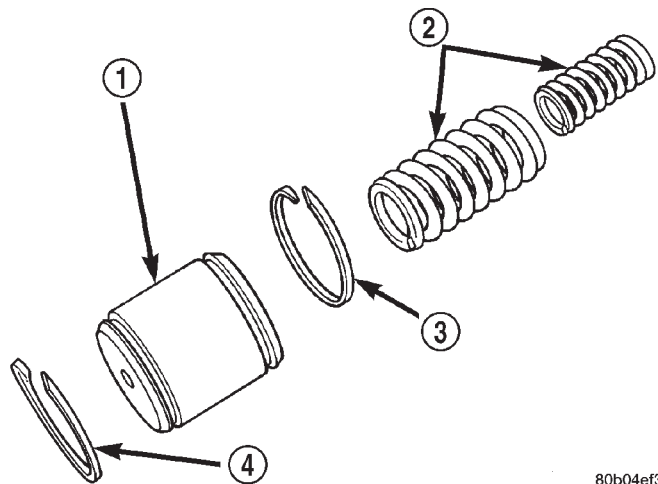

80b04ef3

Fig. 101 Overdrive Accumulator and Springs

1 - OVERDRIVE ACCUMULATOR PISTON
 2 - RETURN SPRINGS
 3 - SEAL RING
 4 - SEAL RING

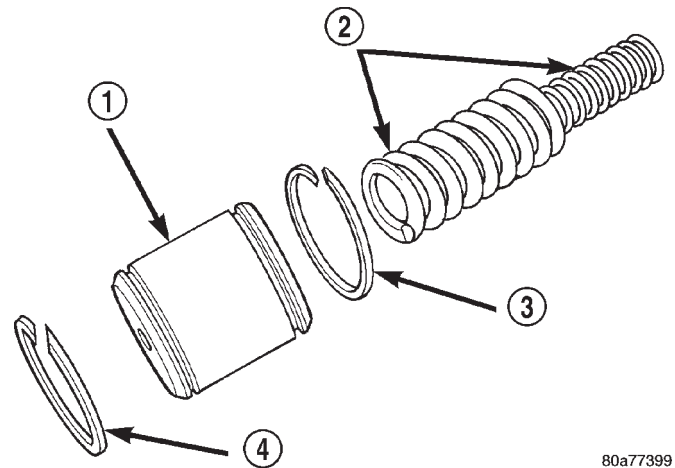

80a77399

Fig. 100 Underdrive Accumulator and Spring

1 - ACCUMULATOR PISTON (UNDERDRIVE)
 2 - RETURN SPRINGS
 3 - SEAL RING
 4 - SEAL RING

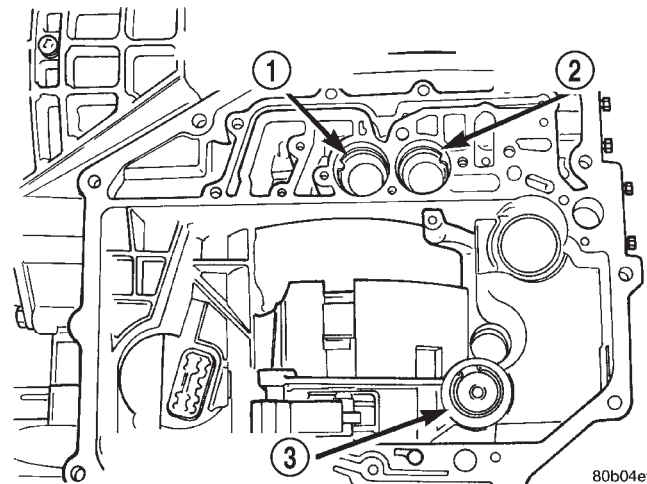

80b04ef8

Fig. 102 Accumulator Locations

1 - OVERDRIVE ACCUMULATOR LOCATION
 2 - UNDERDRIVE ACCUMULATOR LOCATION
 3 - LOW/REVERSE ACCUMULATOR

(5) Lower vehicle and connect the TRS connector.

TRANSAXLE

REMOVAL

The transaxle can be removed **without** having to remove the engine.

- (1) Disconnect battery.
- (2) Remove wiper blades.
- (3) Remove right and left wiper module covers.
- (4) Remove steel cowl/strut support.

CAUTION: Be careful of sharp edges around cowl/wiper area.

(5) Remove engine air inlet tube.

(6) Remove transaxle harness connectors at cowl area.

(7) Remove upper bell housing stud nuts from bell housing studs. Detach heater hose tube and throttle body support bracket.

(8) Remove upper bell housing studs.

(9) Lift vehicle on hoist.

(10) Loosen clamps at intersection of rear exhaust system to front catalytic converter pipes.

(11) Separate rear exhaust from left catalytic converter pipe and right extension pipe.

(12) Remove rear exhaust system.

REMOVAL AND INSTALLATION (Continued)

(13) Remove nuts retaining exhaust pipes to transmission mount.

(14) Loosen clamp at right extension at right catalytic converter. Remove right extension.

(15) Disconnect crankshaft position sensor connector and remove sensor (Fig. 103). The sensor is located on the upper right side of the transaxle bell housing.

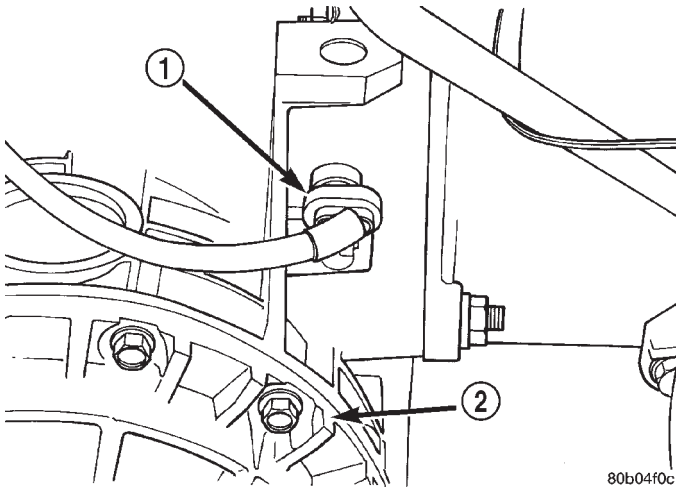

Fig. 103 Crankshaft Position Sensor Location

- 1 - CRANKSHAFT POSITION SENSOR
- 2 - DIFFERENTIAL COVER

- (16) Remove dipstick tube.
- (17) Disconnect the gear selector cable from the transaxle.
- (18) Disconnect transmission range sensor connector. Disconnect input and output speed sensor connector.
- (19) Disconnect and plug transaxle cooler lines at the transaxle.
- (20) Remove lower control arm pinch bolts.
- (21) Pry lower control arms down and out of steering knuckles.

CAUTION: Do not allow drive shaft or CV joint to hang freely. Internal joint damage may occur if allowed to hang freely.

CAUTION: Drive shaft retainer clips and seals located on the stub shafts must be replaced before reinstalling drive shafts.

- (22) Using a pry bar, disconnect the inner tripod joints from the transaxle (Fig. 104).
- (23) Pull bottom of knuckles and drive shafts outward to allow clearance during transaxle removal. The drive shafts do not have to be completely removed from the vehicle. **Do not allow the inner tripod joints to hang unsupported or joint damage may occur.**

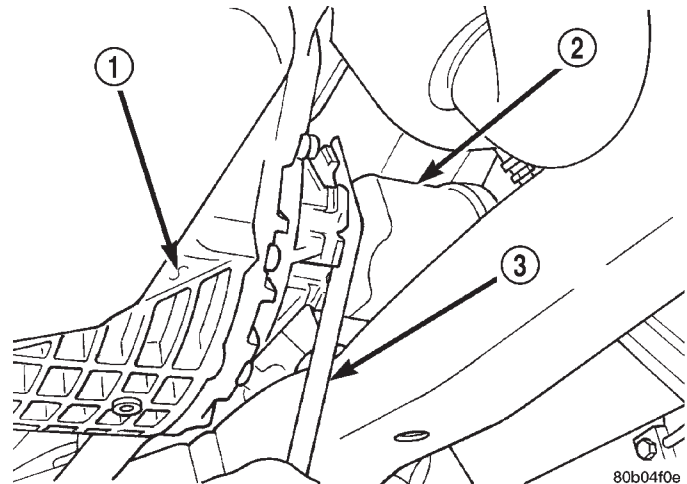

Fig. 104 Drive Shaft Removal

- 1 - TRANSAXLE DIFFERENTIAL
- 2 - DRIVE SHAFT
- 3 - PRY BAR

(24) Disconnect O2 sensor wiring and remove left catalytic converter pipe.

(25) Unbolt starter assembly. Do not disconnect wiring or completely remove the starter from the vehicle. Allow the starter to sit between the engine and the frame.

(26) Remove engine oil pan collar.

(27) Remove torque converter bolts. The torque converter is indexed to the flex plate. Mark the torque converter location to ensure that the torque converter is reinstalled correctly.

CAUTION: The drive plate to torque converter bolts and the drive plate to crankshaft bolts must not be reused. Install new bolts whenever these bolts are removed.

(28) Place a transmission jack under the transaxle. Secure the transaxle to the jack.

(29) Raise transaxle slightly to relieve the weight on the rear transaxle mount.

NOTE: Bolts for the crossmember bridge are different lengths, side to side.

- (30) Remove rear crossmember bridge bolts.
- (31) Remove rear mount adapter plate mounting bolts.
- (32) Remove the rear crossmember bridge, mount, and adapter plate as an assembly.
- (33) Lower the rear of the transaxle to gain access to the bell housing bolts.
- (34) Remove side bell housing bolts.
- (35) Remove dipstick tube from transaxle. Be prepared to plug the dipstick hole when removing dipstick to prevent fluid from spilling out of the transaxle.

REMOVAL AND INSTALLATION (Continued)

(36) Remove connector on top of transaxle for solenoid pack.

(37) The transaxle can now be lowered from the vehicle.

INSTALLATION

(1) When installing transaxle, reverse the above procedure.

CAUTION: To prevent damage to the structural collar, hand tighten all fasteners. This will ensure that the collar is flush against transmission and oil pan before torquing to specifications.

(2) If the torque converter is being replaced, apply a light coating of grease to the crankshaft pilot hole.

(3) Inspect the drive plate for cracks before reinstalling transaxle. If any cracks are found replace the drive plate. Do not attempt to repair a cracked drive plate.

CAUTION: The bolts for the torque converter are a new short-headed design. Bolts from previous year vehicles cannot be used.

(4) Always use new torque converter to drive plate bolts.

NOTE: If the transaxle assembly, TCM, solenoid pack or clutch plates have been replaced, refer to Quick Learn Procedure. This program will allow the transmission control module to compensate for any parts replaced in the electronic transaxle system.

(5) Check and/or adjust gearshift cable. Refer to Shift Linkage in this section for procedure.

(6) Refill transaxle with Mopar ATF Plus 3 (Automatic Transmission Fluid) Type 7176.

OIL PUMP SEAL REPLACEMENT

The transaxle must be removed from the vehicle to replace this oil seal.

REMOVAL

- (1) Remove the transaxle from the vehicle.
- (2) Remove the torque converter from the transaxle bellhousing.
- (3) Use special tool C-3981B to remove oil pump seal (Fig. 105).

INSTALLATION

- (1) Clean and inspect oil pump seal seat. Then install seal using special tool C-4193A (Fig. 106).
- (2) Clean and inspect torque converter hub. If nicks, scratches or hub wear are found, torque converter replacement will be required.

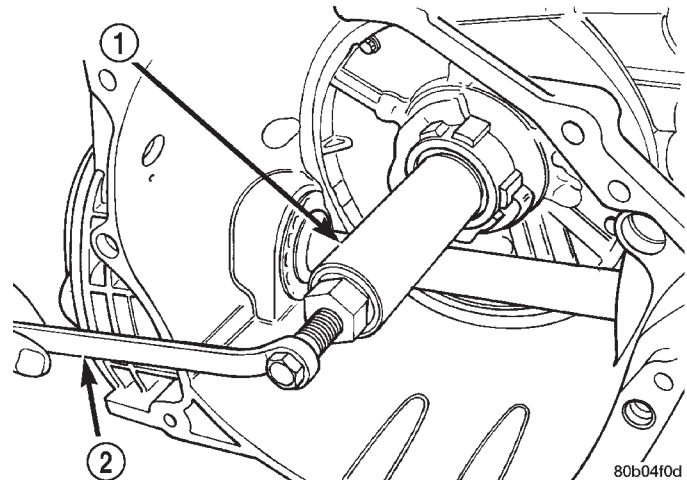

Fig. 105 Oil Seal Removal

- 1 - SPECIAL TOOL C-3981B
- 2 - WRENCH

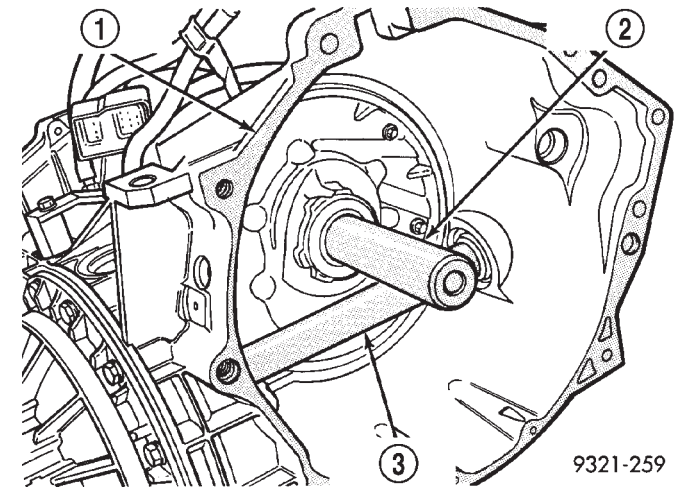

Fig. 106 Oil Seal Installation

- 1 - TRANSAXLE BELL HOUSING
- 2 - SPECIAL TOOL C-4193A
- 3 - LONG STUB SHAFT

CAUTION: If the torque converter is being replaced, apply a light coating of grease to the crankshaft pilot hole. Also inspect the engine drive plate for cracks. If any cracks are found replace the drive plate. Do not attempt to repair a cracked drive plate. Always use new torque converter to drive plate bolts.

- (3) Apply a light film of transmission oil to the torque converter hub and oil seal lips. Then install torque converter into transaxle. Be sure that the hub lugs mesh with the front pump lugs when installing.
- (4) Reinstall the transaxle into the vehicle.

REMOVAL AND INSTALLATION (Continued)

TRANSFER SHAFT SEAL REPLACEMENT

If it has been diagnosed that one or both of the transfer shaft seals are leaking, the following procedure can be used to replace failed seals. This procedure will allow the technician to replace the seals without having to set backlash and measure differential bearing turning torque.

CAUTION: The transfer shaft rear shim, bearing cups and cones, differential bearings and the differential adjusters must be reused to use this procedure. If any of the items listed above require replacement, refer to Differential Recondition section of this manual.

- (1) Remove transaxle from vehicle. Refer to Transaxle Removal and Installation procedure in this section.
- (2) Remove valve body from transaxle.
- (3) Remove solenoid connector from transaxle case.
- (4) Remove long stub shaft from transaxle (Fig. 107).

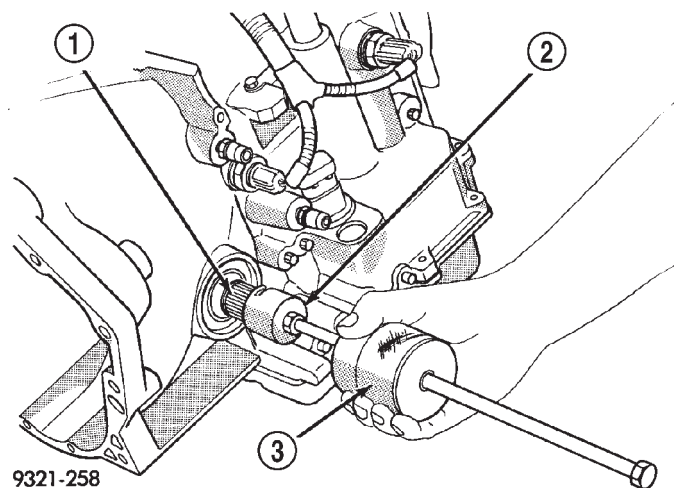

Fig. 107 Long Stub Shaft Removal

- 1 - LONG STUB SHAFT
- 2 - SPECIAL TOOL 6669
- 3 - SLIDE HAMMER C-3752

- (5) Index the inner differential adjuster with a cross hair as shown in (Fig. 108).

CAUTION: If short stub shaft has corrosion, use caution when removing differential cover. Inspect seal and shaft for damage after removal of cover. Replace shaft and/or seal as required.

- (6) Index outer adjuster (Fig. 109). Remove lock bracket and back out adjuster exactly one revolution. Then remove differential cover.

- (7) Remove The inner adjuster lock bracket. Then remove the inner adjuster.

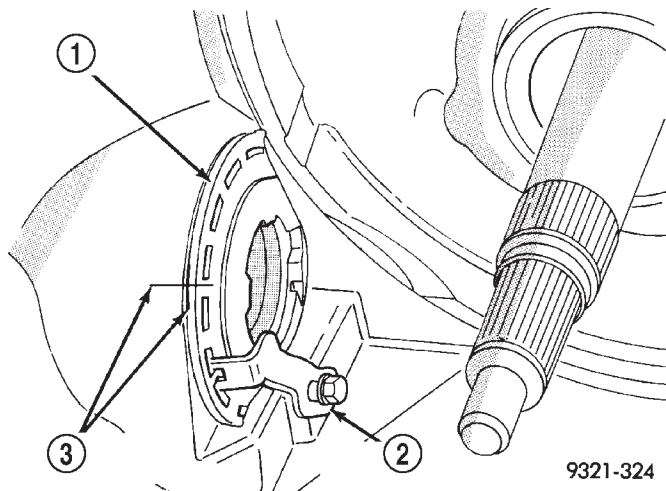

Fig. 108 Indexing Inner Adjuster

- 1 - INNER ADJUSTER
- 2 - ADJUSTER LOCK
- 3 - CROSS HAIR MARKS

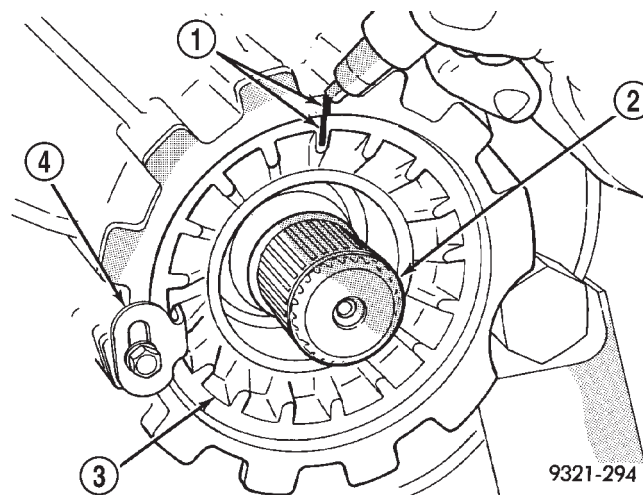

Fig. 109 Indexing Outer Adjuster

- 1 - INDEXING MARKS
- 2 - STUB SHAFT
- 3 - OUTER ADJUSTER
- 4 - ADJUSTER LOCK

CAUTION: Keep the inner adjuster for reinstallation.

- (8) Remove the transfer shaft nut, rear cone, rear cup, oil baffle, rear shim, transfer shaft and transfer shaft seals. Refer to appropriate procedures within this section for detailed removal and installation procedures if required.

CAUTION: Keep rear shim and rear bearing cup cone for reinstallation.

REMOVAL AND INSTALLATION (Continued)

(9) Install transfer shaft, transfer shaft seals, oil baffle, rear cup, rear shim, rear cone and a new nut. Refer to appropriate procedures within this section for detailed removal and installation procedures if required.

(10) Install a new o-ring onto the inner adjuster.

(11) Lube inner adjuster threads and o-ring with gear oil and reinstall to the cross haired index marks.

(12) Reinstall the inner adjuster locking bracket.

(13) Install the differential carrier. Install stub shaft seal protector.

(14) Install the differential cover/outer adjuster assembly with Mopar Silicone Sealant applied. Install and tighten differential cover bolts.

(15) Tighten the outer adjuster 3/4 of a turn. Seat bearings by turning differential carrier three or four turns in both directions. Finish tightening the adjuster 1/4 turn to its index mark (original location).

(16) Reinstall the outer adjuster locking bracket.

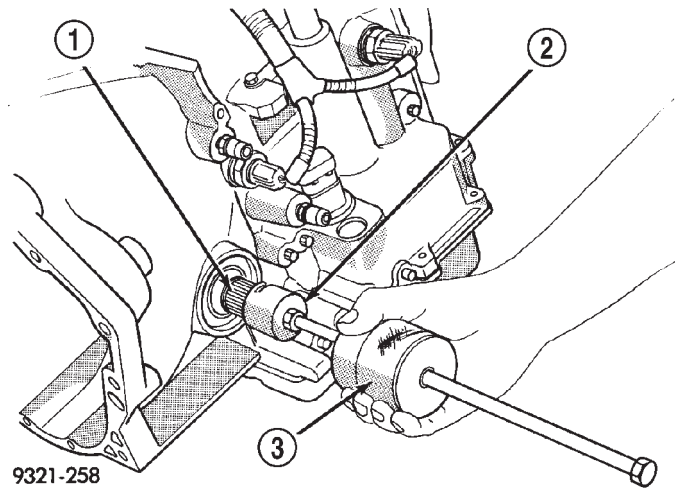

9321-258

Fig. 110 Long Stub Shaft Removal

- 1 - LONG STUB SHAFT
- 2 - SPECIAL TOOL 6669
- 3 - SLIDE HAMMER C-3752

LONG STUB SHAFT SEAL REPLACEMENT

If it has been diagnosed that the long stub shaft seal is leaking, the following procedure can be used to replace failed seal. This procedure will allow the replacement of the seals without having to set backlash and measure differential bearing turning torque.

CAUTION: The differential bearings and the differential adjusters must be reused in order to use this procedure. If any of the items listed above require replacement, this procedure cannot be used. Refer to Differential Recondition section of this manual.

(1) Remove transaxle from vehicle. Refer to Transaxle Removal and Installation procedure in this section.

(2) Remove long stub shaft from transaxle (Fig. 110).

To replace the long stub shaft bearing, install stub shaft in soft-jawed vise. Remove the stub shaft bearing C-clip (Fig. 111). Install bearing splitter onto the shaft. Install Special Tool # P-334 under the bearing. Using a shop press, remove the bearing from the stub shaft (Fig. 112).

To install the stub shaft bearing, position new bearing onto the stub shaft. Install stub shaft into shop press. Position Special Tool # 6558 above bearing. Press bearing onto shaft (Fig. 113).

(3) Index the inner differential adjuster with a cross hair as shown in (Fig. 114).

CAUTION: If short stub shaft has corrosion, use caution when removing differential cover. Inspect seal and shaft for damage after removal of cover. Replace shaft and/or seal as required.

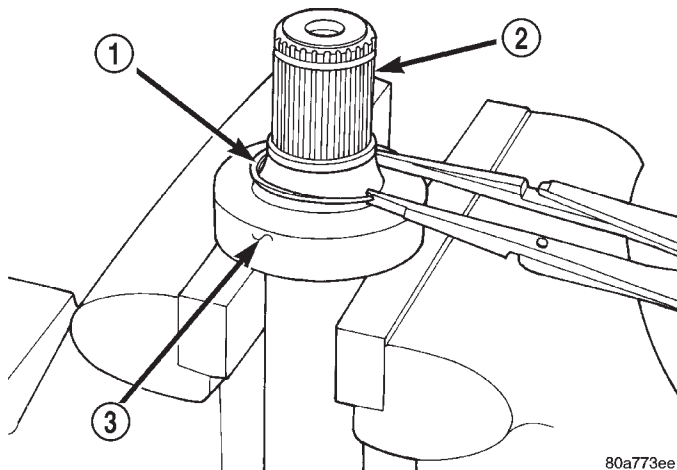

80a773ee

Fig. 111 Stub Shaft Bearing C-clip

- 1 - C-CLIP
- 2 - LONG STUB SHAFT
- 3 - STUB SHAFT BEARING

(4) Index outer adjuster (Fig. 115). Remove lock bracket and back out adjuster exactly one revolution. Then remove differential cover.

(5) Remove The inner adjuster lock bracket. Then remove the inner adjuster.

CAUTION: Keep the inner adjuster for reinstallation.

(6) Lube inner adjuster threads with gear oil and reinstall to the cross haired index marks.

(7) Install the differential carrier. Then install stub shaft seal protector.

(8) Install the differential cover/outer adjuster assembly with sealant applied. Install and tighten differential cover bolts.

REMOVAL AND INSTALLATION (Continued)

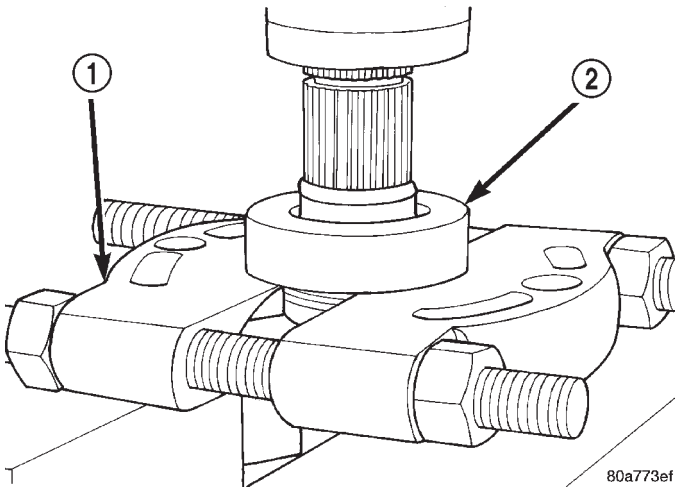

Fig. 112 Remove Stub Shaft Bearing C-clip

- 1 - BEARING SPLITTER
- 2 - STUB SHAFT BEARING

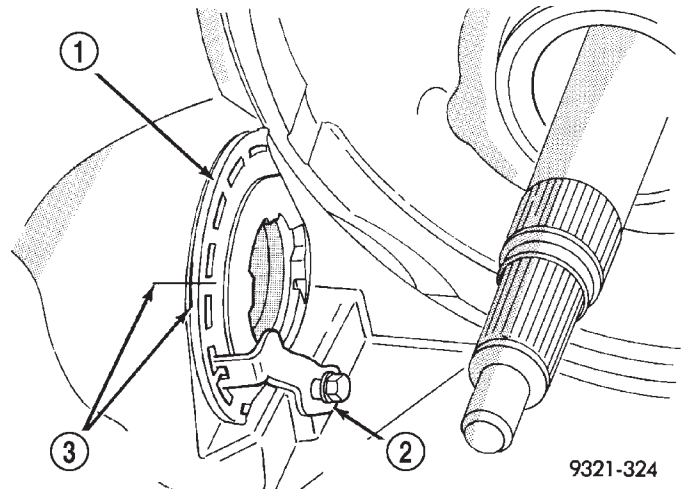

Fig. 114 Indexing Inner Adjuster

- 1 - INNER ADJUSTER
- 2 - ADJUSTER LOCK
- 3 - CROSS HAIR MARKS

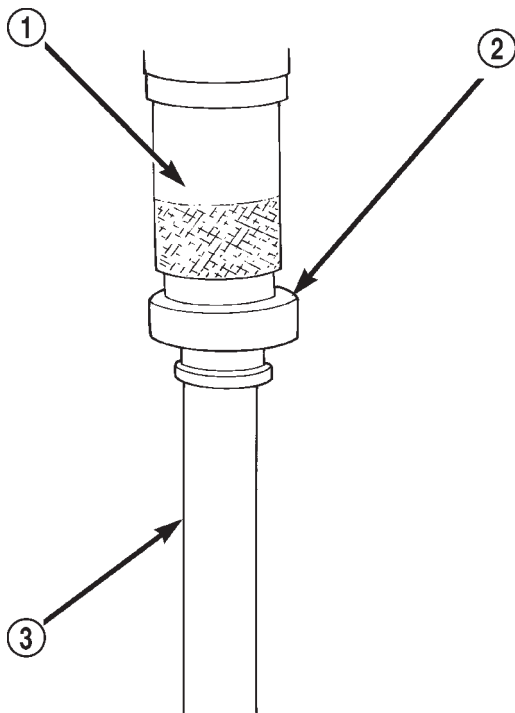

Fig. 113 Install Bearing Onto Shaft

- 1 - TOOL 6558
- 2 - STUB SHAFT BEARING
- 3 - STUB SHAFT

(9) Tighten the outer adjuster 3/4 of a turn. Seat bearings by turning differential carrier three or four turns in both directions. Finish tightening the adjuster 1/4 turn to its index mark (original location).

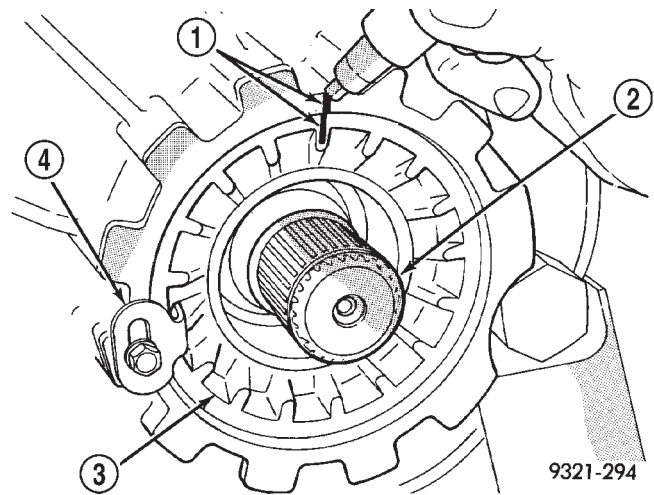

Fig. 115 Indexing Outer Adjuster

- 1 - INDEXING MARKS
- 2 - STUB SHAFT
- 3 - OUTER ADJUSTER
- 4 - ADJUSTER LOCK

(10) Reinstall long stub shaft, fill differential with fluid and reinstall transaxle.

(11) After installing transaxle check transmission side fluid level.

SHORT STUB SHAFT SEAL REPLACEMENT

The following procedure can be used to replace the short stub shaft seal without having to remove the transaxle from the vehicle. If the adjuster or bearing located behind the adjuster require replacement, do not use this procedure. Refer to Differential Recondition section of this manual.

REMOVAL AND INSTALLATION (Continued)

- (1) Place vehicle in neutral and lift vehicle on hoist.
- (2) Remove short driveshaft.
- (3) Index the outer adjuster (Fig. 116).

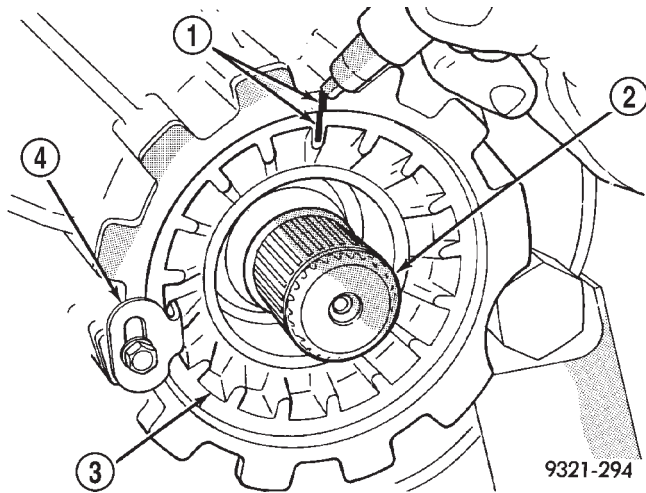

Fig. 116 Indexing Outer Adjuster

- 1 - INDEXING MARKS
- 2 - STUB SHAFT
- 3 - OUTER ADJUSTER
- 4 - ADJUSTER LOCK

- (4) Remove outer adjuster lock (Fig. 117).

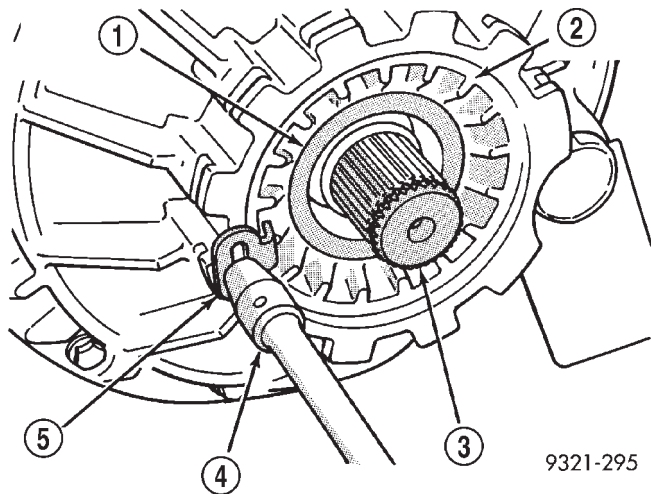

Fig. 117 Outer Adjuster Lock Removal

- 1 - OIL SEAL
- 2 - OUTER ADJUSTER
- 3 - STUB SHAFT
- 4 - SOCKET
- 5 - ADJUSTER LOCK

- (5) Using special tool 6503 loosen outer adjuster, then retighten to the index mark using a torque wrench. Record the amount of torque required to return the index marks to their original location. Remove the adjuster.

- (6) Use special tool 6558 to remove old seal and install new seal (Fig. 118).

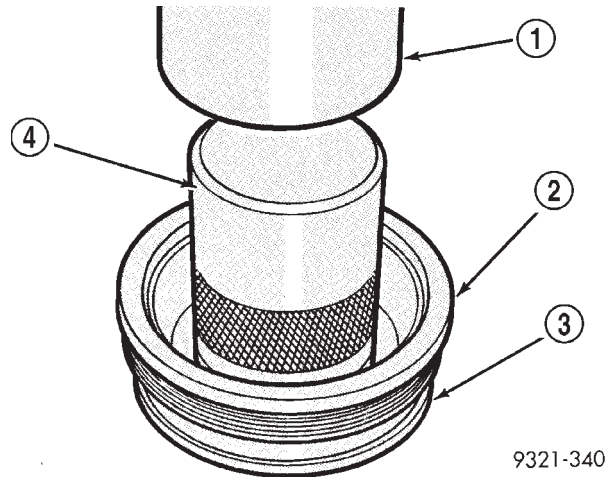

Fig. 118 Seal Removal and Installation

- 1 - ARBOR PRESS
- 2 - OUTER DIFFERENTIAL ADJUSTER
- 3 - O-RING
- 4 - SPECIAL TOOL 6558

- (7) Inspect stub shaft for corrosion (Fig. 119). If corrosion exists, wrap stub shaft with wax paper and install seal protector over wax paper.

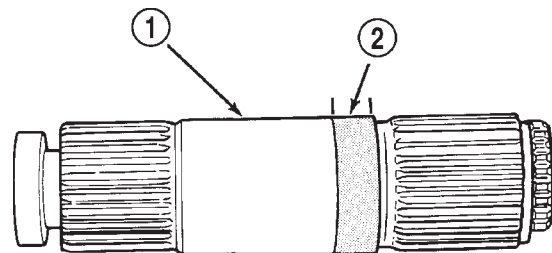

Fig. 119 Stub Shaft Corrosion

- 1 - STUB SHAFT
- 2 - CORROSION AREA

- (8) Lube O-ring, threads on adjuster, seal protector and seal lips with gear oil before installing.

- (9) Install outer adjuster into transaxle case and tighten adjuster within 10 ft. lbs. of the torque reading recorded in step five.

- (10) Rotate ring gear three or four revolutions in both directions to seat differential bearings.

- (11) Continue tightening outer adjuster until index marks line up (original location).

- (12) Install adjuster lock.

- (13) Install new driveshaft retaining circlip and O-ring on stub shaft. Then reinstall driveshaft.

- (14) Check fluid level in differential and adjust as required.

- (15) Road test and recheck for leaks as required.

DISASSEMBLY AND ASSEMBLY

VALVE BODY

DISASSEMBLY

- (1) Remove manual shaft seal.
- (2) Remove manual shaft screw (Fig. 120).

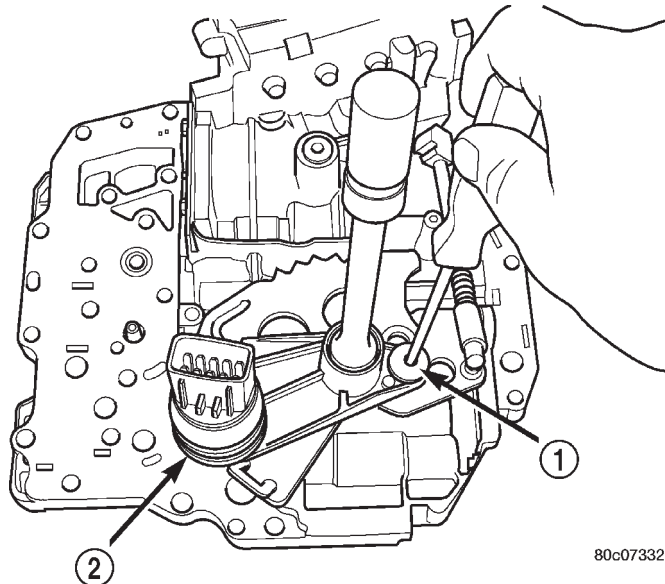

Fig. 120 TRS/Manual Shaft Retaining Screw

- 1 - SCREW
- 2 - TRS

- (3) Remove Transmission Range Sensor (TRS) and manual shaft (Fig. 121).

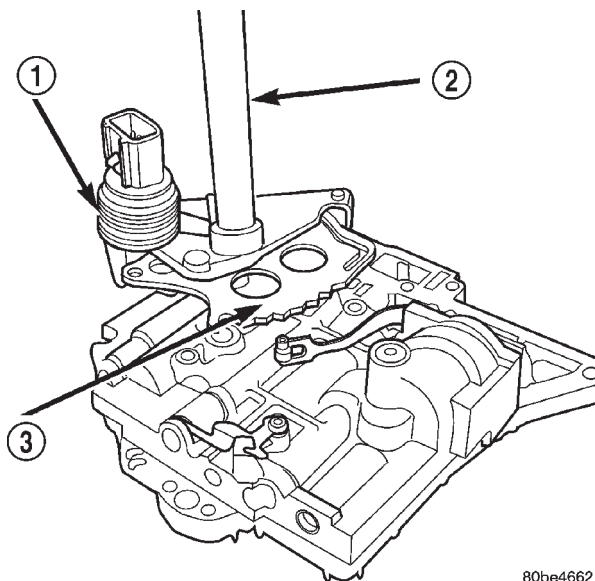

Fig. 121 Manual Shaft/Rooster Comb and Transmission Range Sensor

- 1 - TRANSMISSION RANGE SENSOR
- 2 - MANUAL SHAFT
- 3 - ROOSTER COMB

- (4) Remove Solenoid/Pressure Switch Assembly from valve body (Fig. 122).

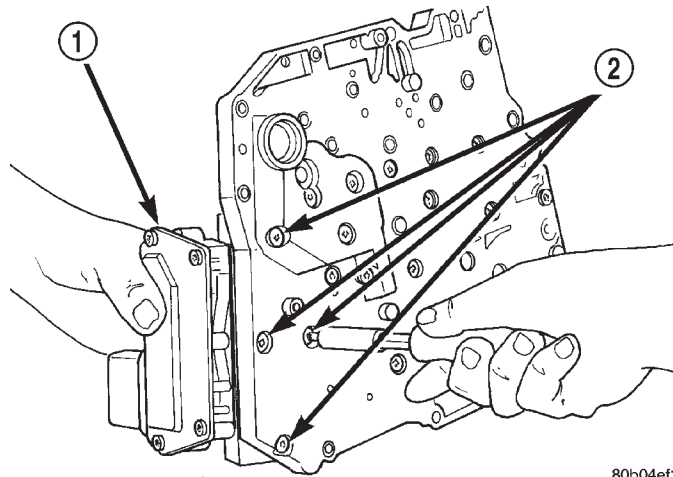

Fig. 122 Solenoid/Pressure Switch Assembly Location

- 1 - SOLENOID PACK
- 2 - SOLENOID RETAINING SCREWS

- (5) Remove valve body stiffener plate (Fig. 123).

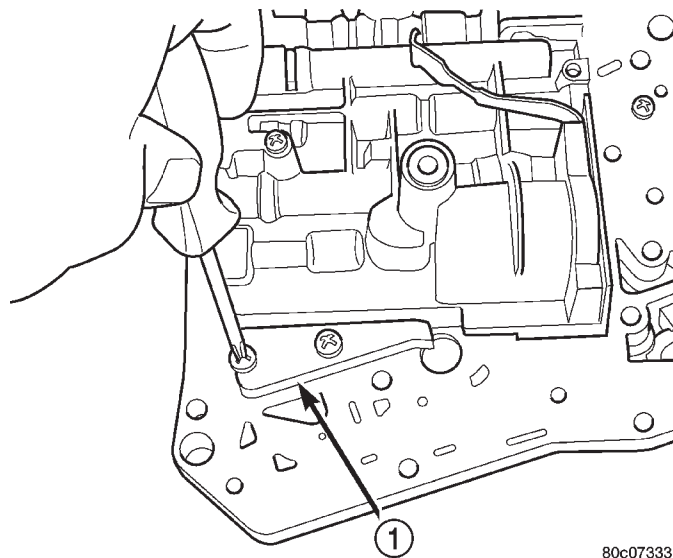

Fig. 123 Stiffener Plate

- 1 - STIFFENER PLATE

- (6) Invert valve body assembly and remove transfer plate-to-valve body screws (Fig. 124).

- (7) Remove transfer/separator plate from valve body (Fig. 125)

- (8) Remove separator plate-to-transfer plate screws (Fig. 126).

- (9) Remove separator plate from transfer plate (Fig. 127).

- (10) Remove oil screen (Fig. 128) from transfer plate.

DISASSEMBLY AND ASSEMBLY (Continued)

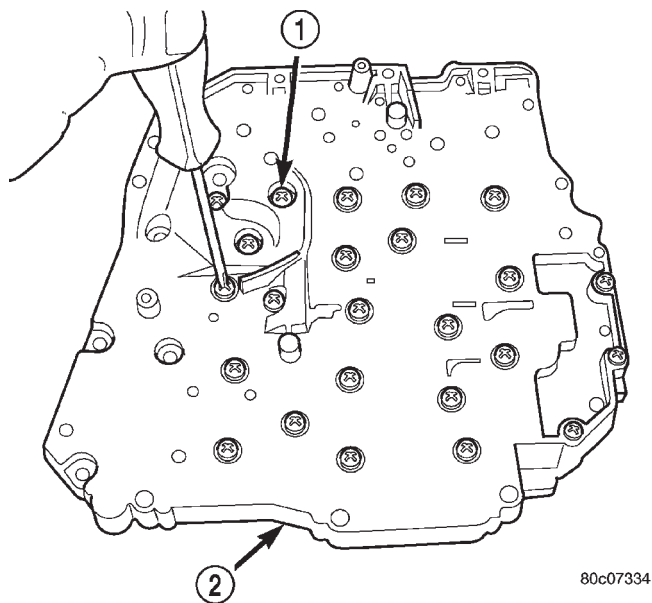

Fig. 124 Transfer Plate-to-Valve Body Screws

- 1 - SCREW (24)
- 2 - TRANSFER PLATE

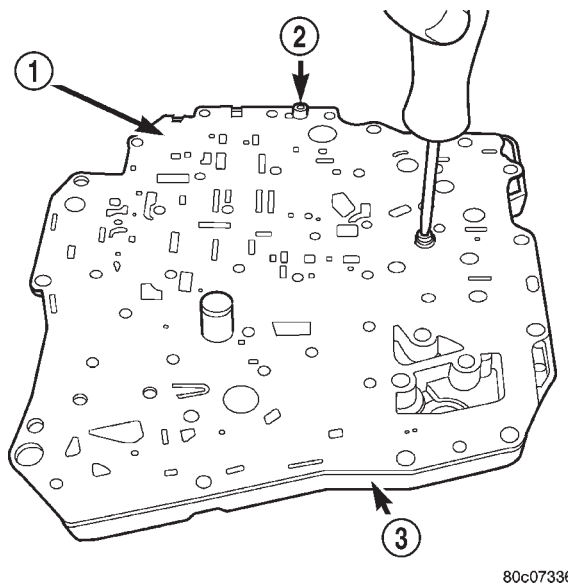

Fig. 126 Separator Plate-to-Transfer Plate Screws

- 1 - SEPARATOR PLATE
- 2 - SCREW (2)
- 3 - TRANSFER PLATE

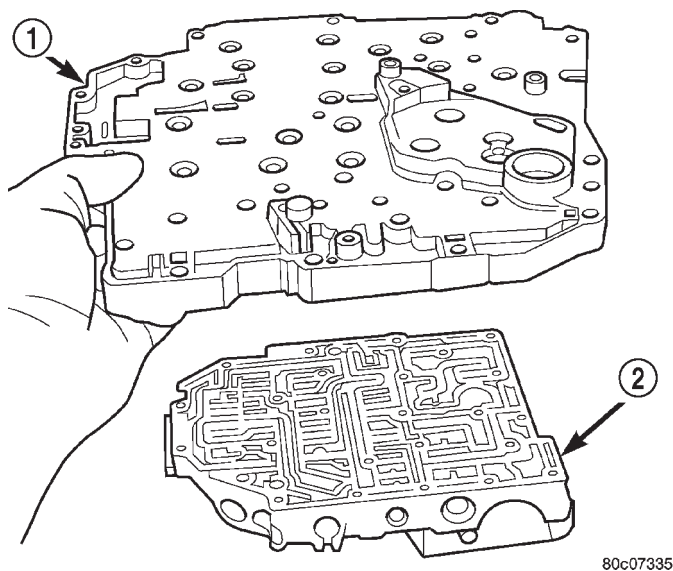

Fig. 125 Transfer Plate and Valve Body

- 1 - TRANSFER PLATE
- 2 - VALVE BODY

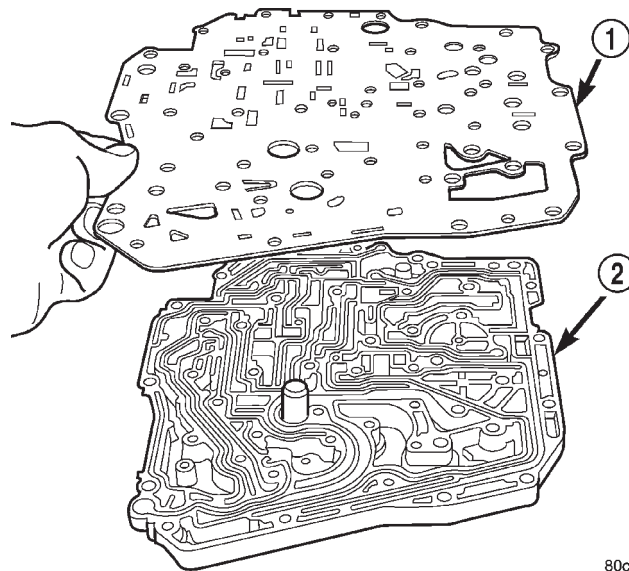

Fig. 127 Separator Plate

- 1 - SEPARATOR PLATE
- 2 - TRANSFER PLATE

(11) Remove thermal valve (Fig. 129) from transfer plate.

(12) Remove valve body check balls. Note their location for assembly ease (Fig. 130).

(13) Remove 2/4 accumulator assembly as shown in (Fig. 131).

(14) Remove dual retainer plate from valve body. Use special tool 6301 to remove plate (Fig. 132).

DISASSEMBLY AND ASSEMBLY (Continued)

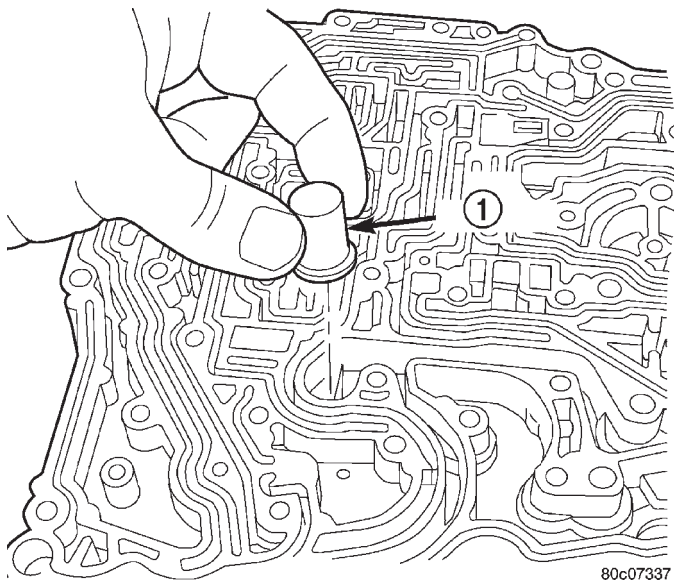
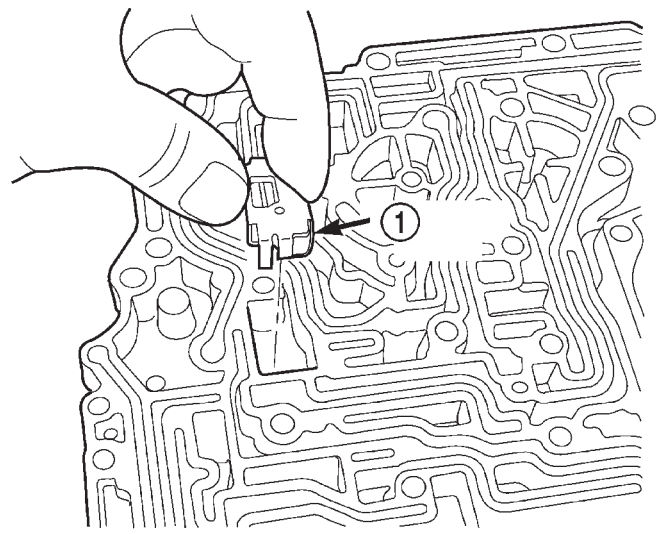

Fig. 128 Oil Screen

80c07337



80c07338

Fig. 129 Thermal Valve

1 - OIL SCREEN

1 - THERMAL VALVE

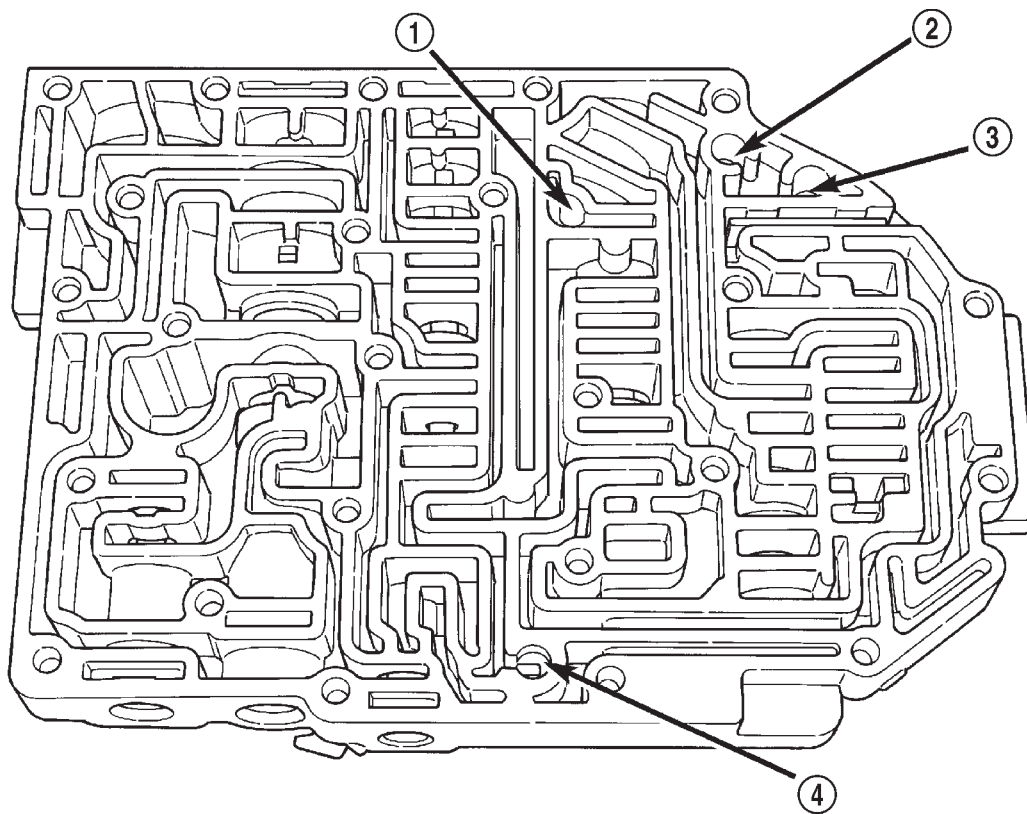

80c07030

Fig. 130 Ball Check Location

1 - (#4) BALL CHECK LOCATION
2 - (#2) BALL CHECK LOCATION

3 - (#5) BALL CHECK LOCATION
4 - (#3) BALL CHECK LOCATION

DISASSEMBLY AND ASSEMBLY (Continued)

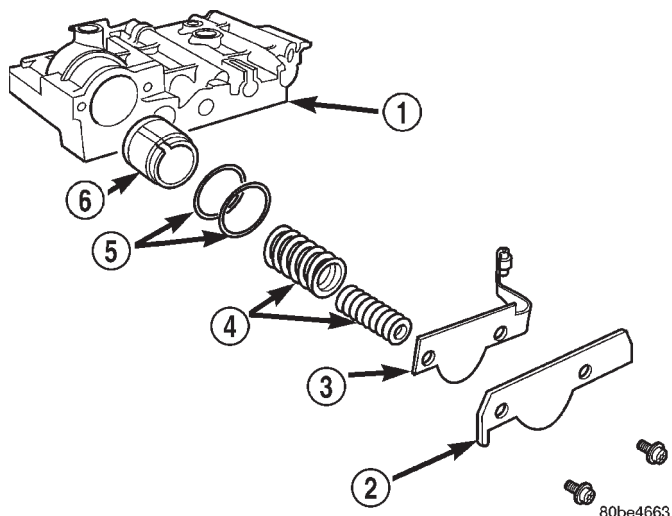

Fig. 131 2/4 Accumulator Assembly

- 1 - VALVE BODY
- 2 - RETAINER PLATE
- 3 - DETENT SPRING
- 4 - SPRINGS
- 5 - SEALS
- 6 - PISTON

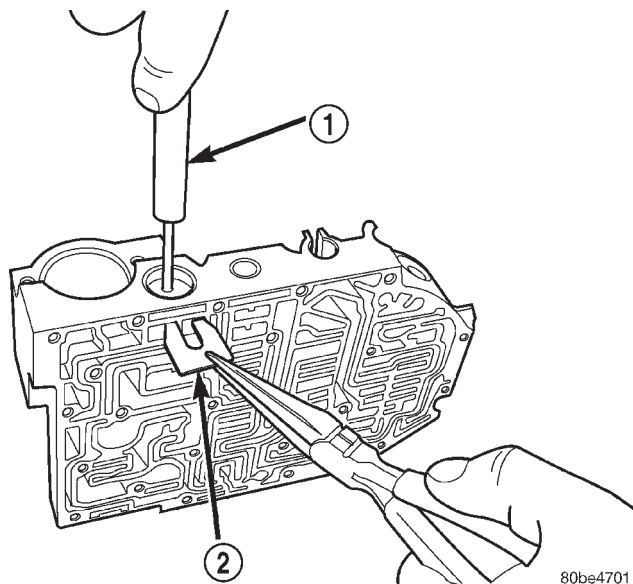

Fig. 133 Remove Regulator Valve Spring Retainer using Tool 6302

- 1 - TOOL 6302
- 2 - RETAINER

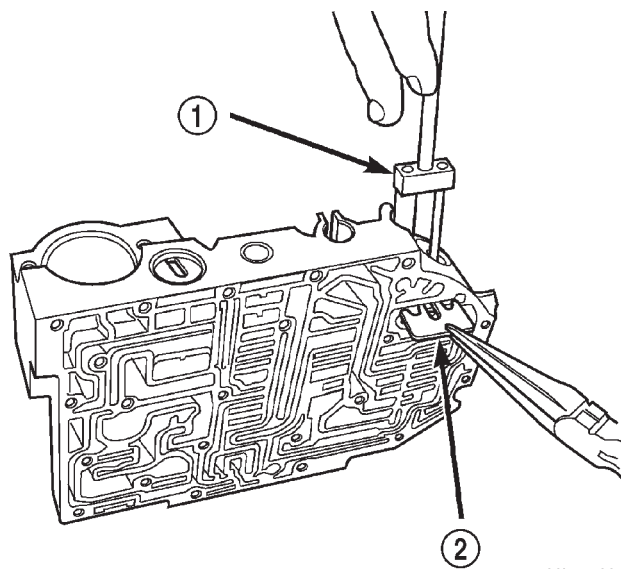

Fig. 132 Remove or Install Dual Retainer Plate

- 1 - TOOL 6301
- 2 - RETAINER

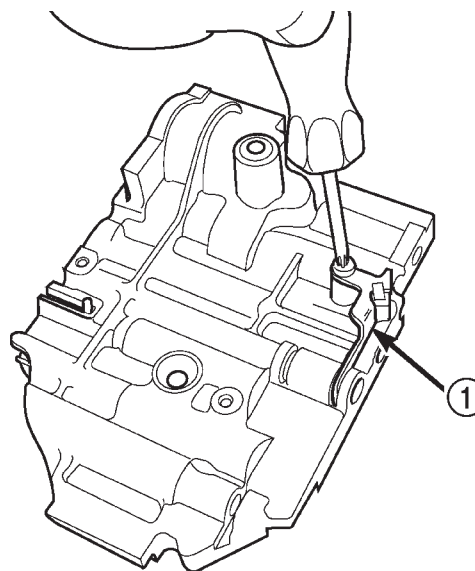

Fig. 134 Remove Vent Reservoir Check Valve Retainer

- 1 - RETAINER

(15) Remove regulator valve spring retainer (Fig. 133).

(16) Remove the vent reservoir check valve retainer (Fig. 134).

(17) Remove vent reservoir check valve and spring (Fig. 135).

(18) Remove remaining retainers as shown in (Fig. 136).

(19) Remove valves and springs as shown in (Fig. 137).

(20) Cleanliness through entire disassembly and assembly of the valve body cannot be overemphasized. When disassembling, each part should be washed in a suitable solvent, then dried by compressed air. **Do not wipe parts with shop towels.** All mating surfaces in the valve body are accurately machined; therefore, careful handling of all parts must be exercised to avoid nicks or burrs.

DISASSEMBLY AND ASSEMBLY (Continued)

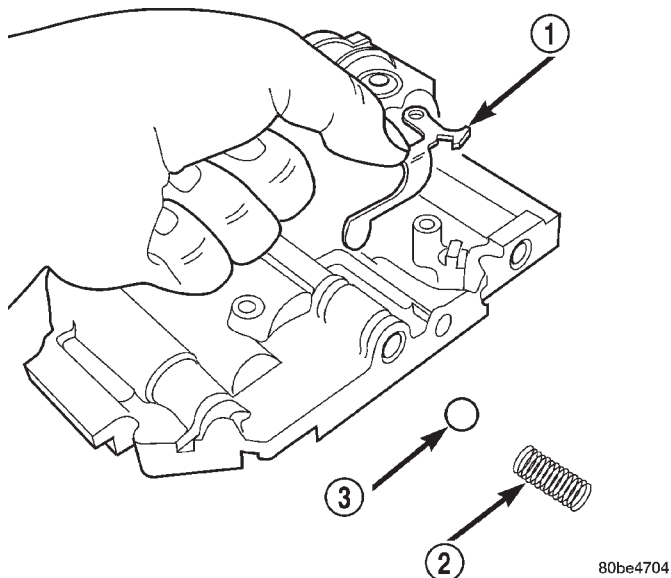

Fig. 135 Vent Reservoir Check Valve and Spring

- 1 - RETAINER
- 2 - SPRING
- 3 - BALL

80be4704

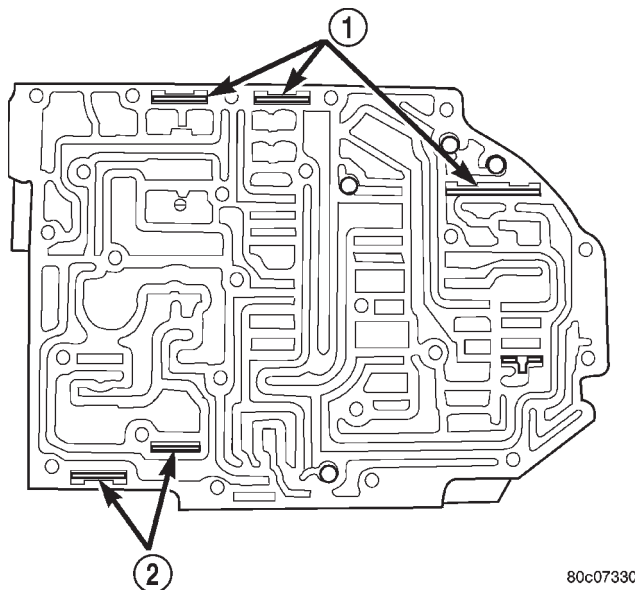

Fig. 136 Valve Retainer Location

- 1 - RETAINER
- 2 - RETAINER

80c07330

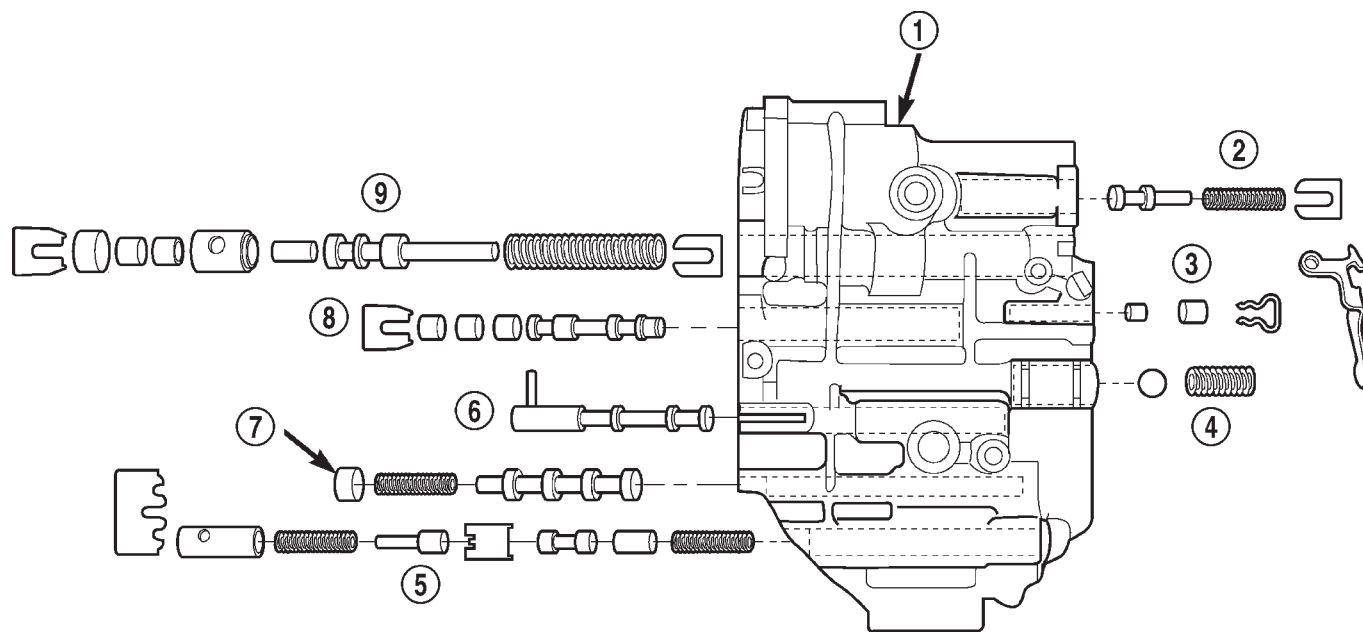

Fig. 137 Springs and Valves Location

- 1 - VALVE BODY
- 2 - T/C REGULATOR VALVE
- 3 - L/R SWITCH VALVE
- 4 - VENT RESERVOIR CHECK VALVE
- 5 - CONVERTER CLUTCH CONTROL VALVE
- 6 - MANUAL VALVE
- 7 - CONVERTER CLUTCH SWITCH VALVE
- 8 - SOLENOID SWITCH VALVE
- 9 - REGULATOR VALVE

80bdbd80

DISASSEMBLY AND ASSEMBLY (Continued)

ASSEMBLY

- (1) Install valves and springs as shown in (Fig. 137).
- (2) Install regulator valve spring retainer (Fig. 138).

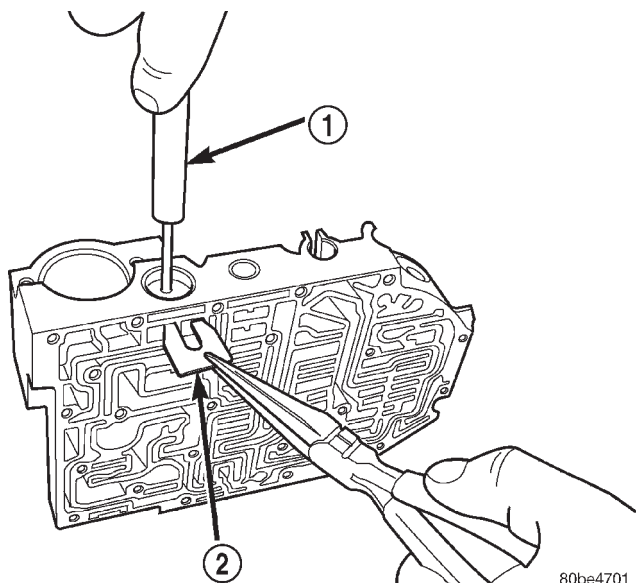

Fig. 138 Install Regulator Valve Spring Retainer using Tool 6302

- 1 - TOOL 6302
- 2 - RETAINER

- (3) Install dual retainer plate using Tool 6301 (Fig. 139).

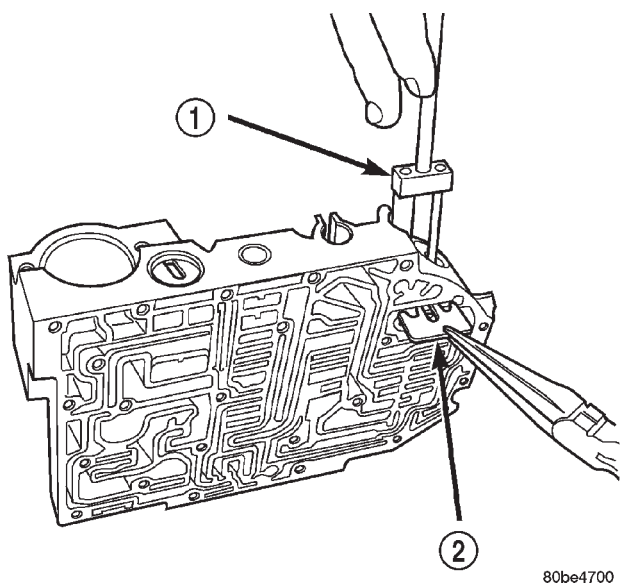

Fig. 139 Install Dual Retainer Plate using Tool 6301

- 1 - TOOL 6301
- 2 - RETAINER

- (4) Install vent reservoir check valve and spring (Fig. 140).

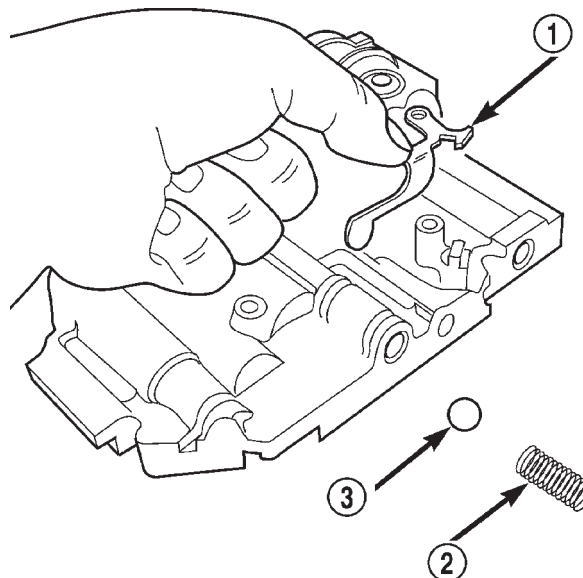

Fig. 140 Vent Reservoir Check Valve and Spring

- 1 - RETAINER
- 2 - SPRING
- 3 - BALL

- (5) Install the vent reservoir check valve retainer (Fig. 141).

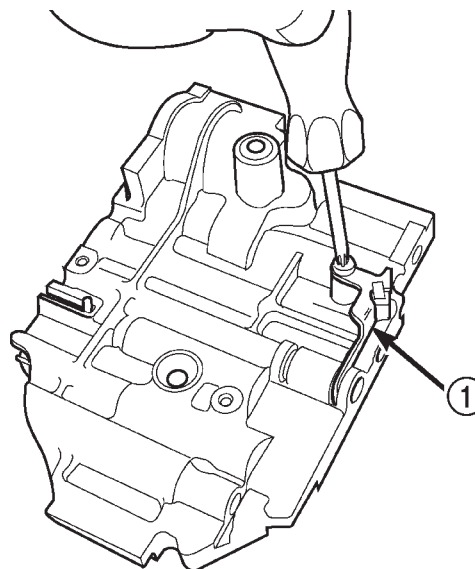

Fig. 141 Install Vent Reservoir Check Valve Retainer

- 1 - RETAINER

- (6) Verify that all retainers are installed as shown in (Fig. 142). Retainers should be flush or below valve body surface.

- (7) Install 2/4 Accumulator components as shown in (Fig. 143). Torque 2/4 Accumulator retainer plate to 5 N·m (45 in. lbs.).

- (8) Install check balls into position as shown in (Fig. 144). If necessary, secure them with petrolatum or transmission assembly gel for assembly ease.

DISASSEMBLY AND ASSEMBLY (Continued)

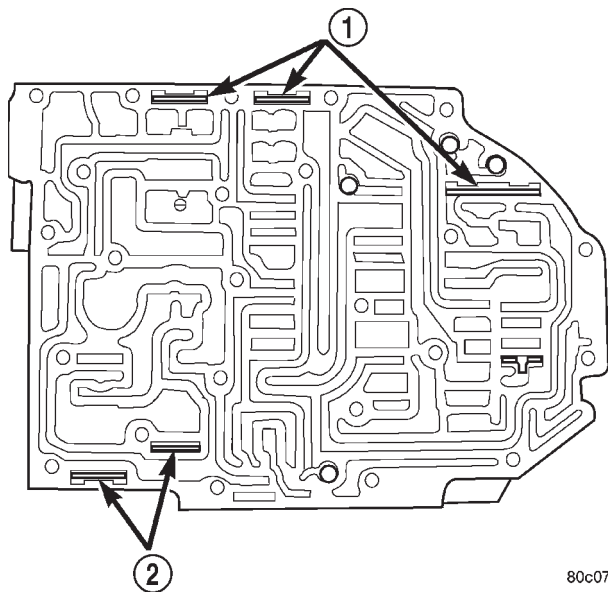

Fig. 142 Valve Retainer Location

- 1 - RETAINER
- 2 - RETAINER

80c07330

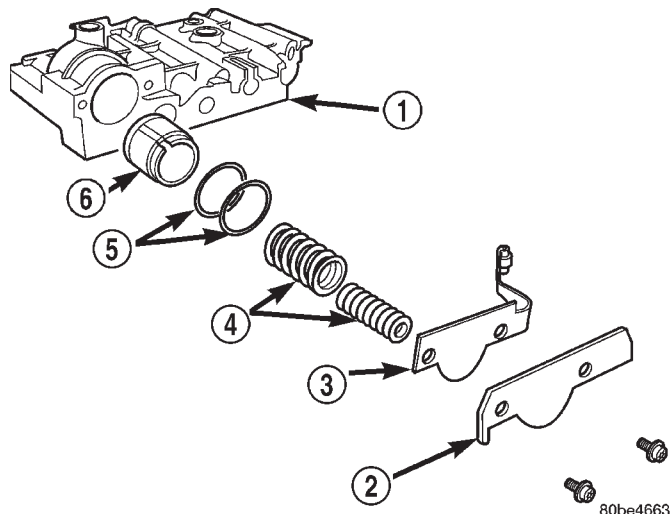

Fig. 143 2/4 Accumulator Assembly

- 1 - VALVE BODY
- 2 - RETAINER PLATE
- 3 - DETENT SPRING
- 4 - SPRINGS
- 5 - SEALS
- 6 - PISTON

80be4663

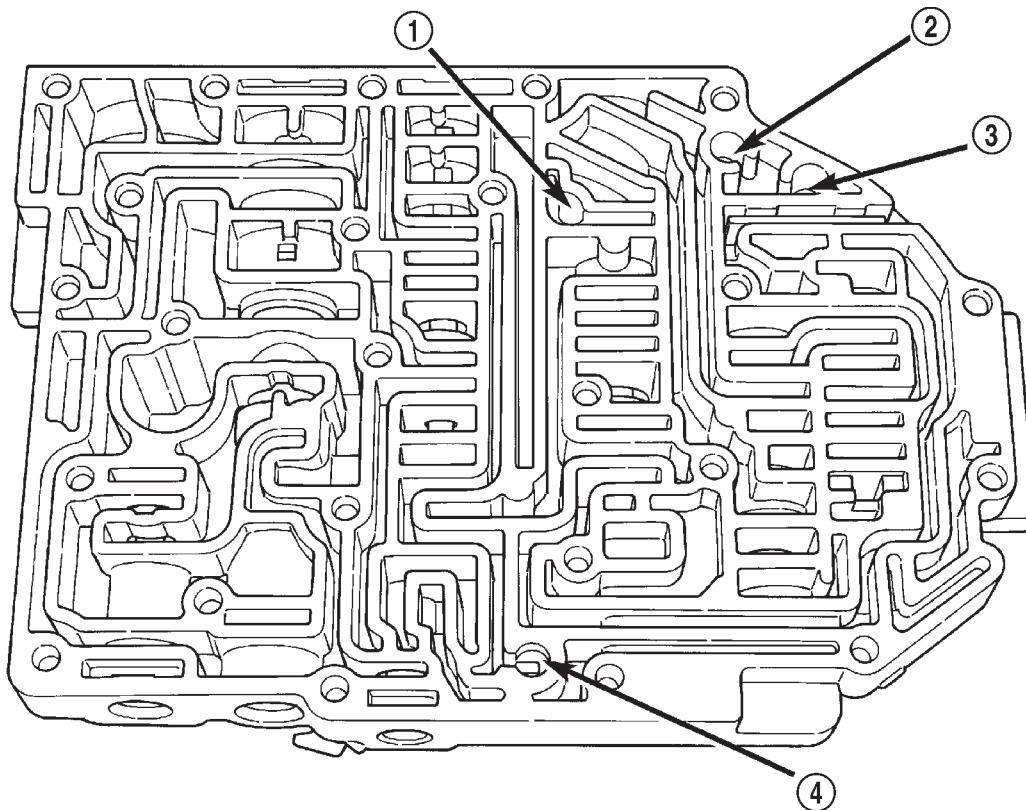

Fig. 144 Ball Check Location

- 1 - (#4) BALL CHECK LOCATION
- 2 - (#2) BALL CHECK LOCATION
- 3 - (#5) BALL CHECK LOCATION
- 4 - (#3) BALL CHECK LOCATION

80c07030

DISASSEMBLY AND ASSEMBLY (Continued)

(9) Install thermal valve to the transfer plate (Fig. 145).

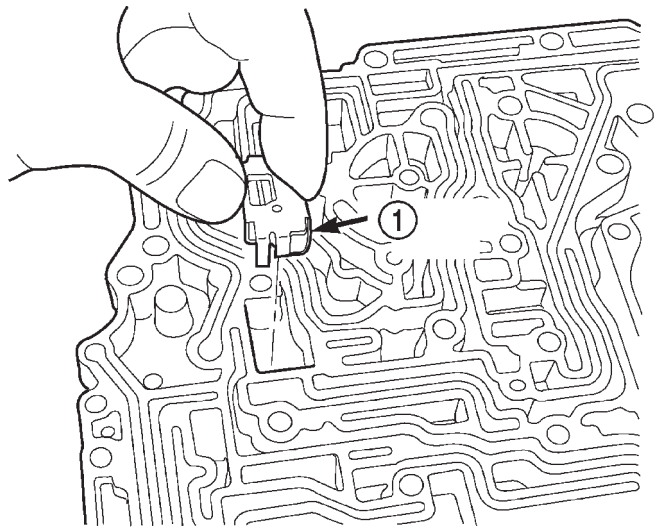

80c07338

Fig. 145 Install Thermal Valve to Transfer Plate

1 - THERMAL VALVE

(10) Install oil screen to transfer plate (Fig. 146).

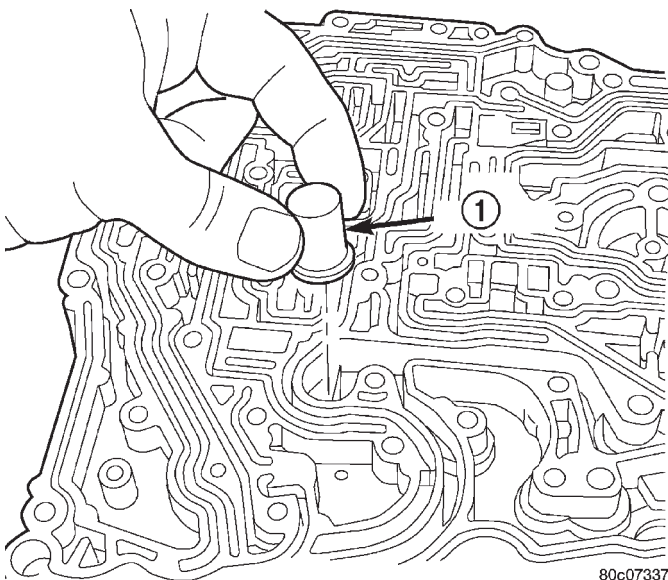

80c07337

Fig. 146 Install Oil Screen to Transfer Plate

1 - OIL SCREEN

(11) Install separator plate to transfer plate (Fig. 147).

(12) Install the two separator plate-to-transfer plate screws (Fig. 148).

(13) Install the transfer plate to the valve body (Fig. 149).

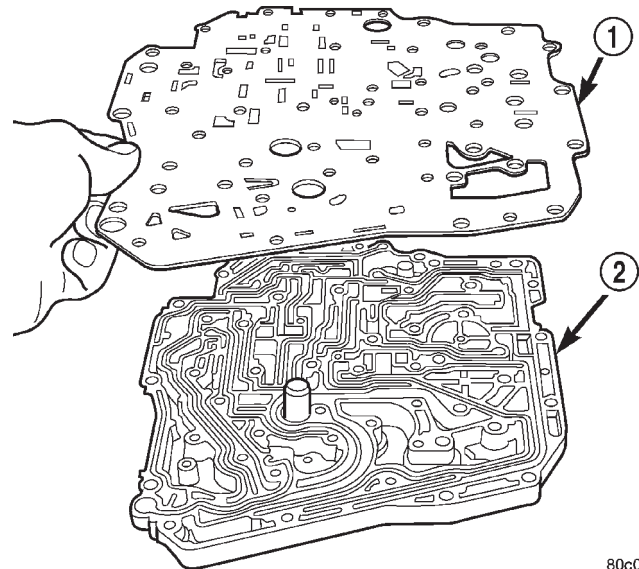

80c07339

Fig. 147 Install Separator Plate to Transfer Plate

1 - SEPARATOR PLATE
2 - TRANSFER PLATE

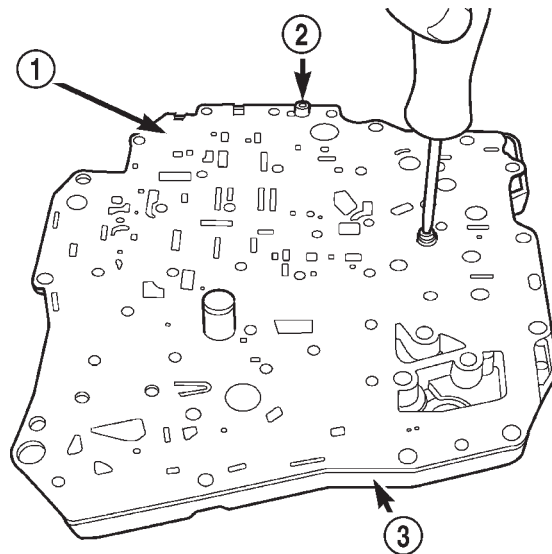

80c07336

Fig. 148 Install Separator Plate-to-Transfer Plate Screws

1 - SEPARATOR PLATE
2 - SCREW (2)
3 - TRANSFER PLATE

(14) Install the transfer plate-to-valve body screws (Fig. 150) and torque to 5 N·m (45 in. lbs.).

(15) Install the stiffener plate (Fig. 151).

(16) Install the solenoid/pressure switch assembly and to the transfer plate (Fig. 152) and torque to 6 N·m (53 in. lbs.).

DISASSEMBLY AND ASSEMBLY (Continued)

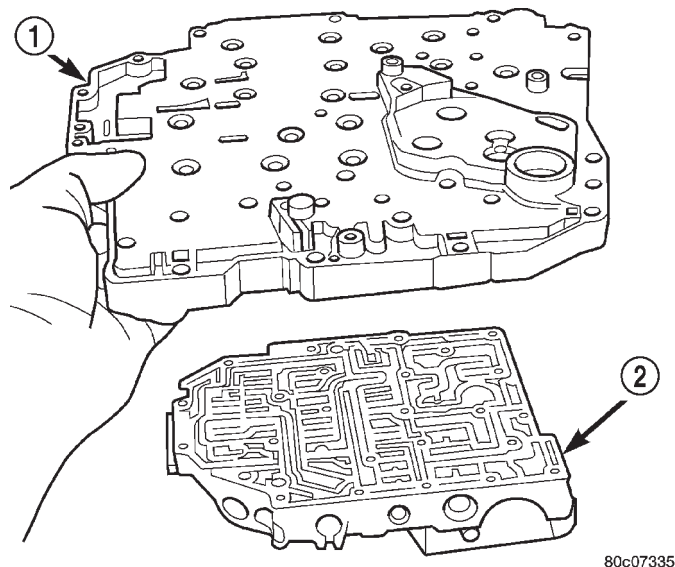

80c07335

Fig. 149 Install Transfer Plate to Valve Body

- 1 - TRANSFER PLATE
- 2 - VALVE BODY

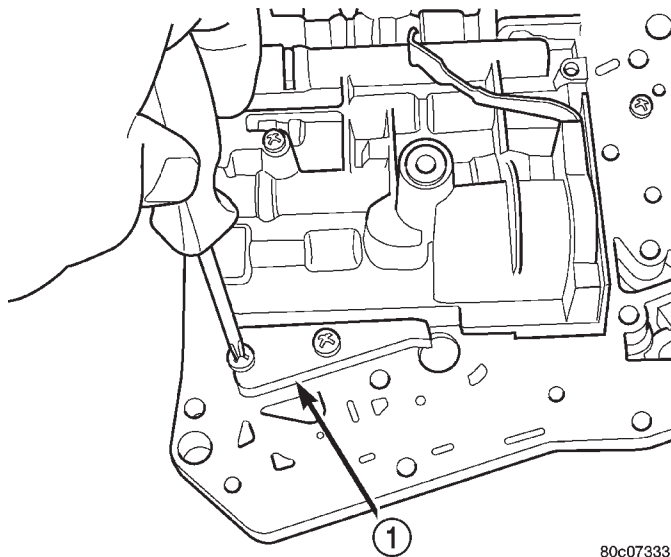

80c07333

Fig. 151 Install Stiffener Plate

- 1 - STIFFENER PLATE

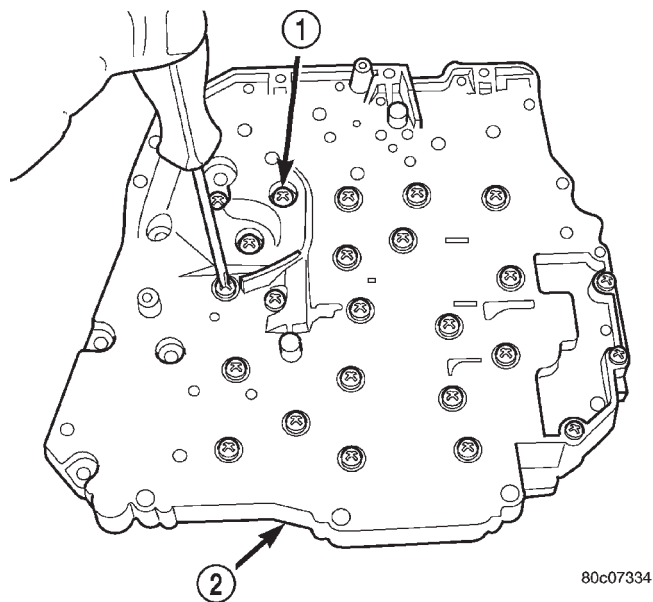

80c07334

Fig. 150 Install Transfer Plate-to-Valve Body Screws

- 1 - SCREW (24)
- 2 - TRANSFER PLATE

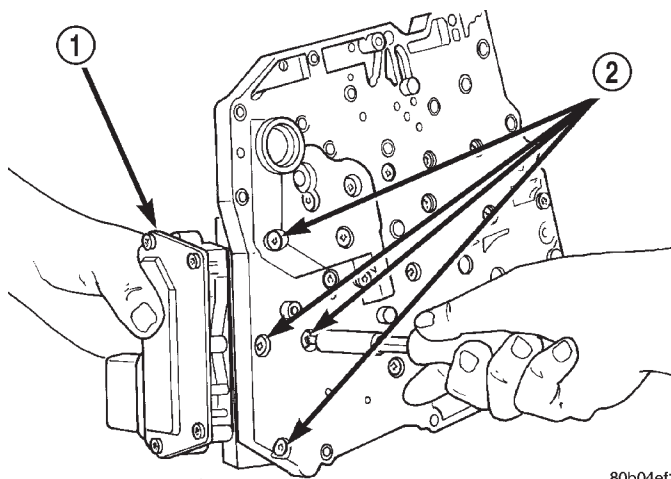

80b04ef1

Fig. 152 Solenoid/Pressure Switch Assembly

- 1 - SOLENOID PACK
- 2 - SOLENOID RETAINING SCREWS

TRANSAXLE—DISASSEMBLY

Before disassembling transaxle, move the shift lever clockwise as far as it will go. This should be one position past the L position. Then remove the shift lever.

NOTE: Tag all clutch pack assemblies, as they are removed, for reassembly identification.

CAUTION: Do not intermix clutch discs or plates as the unit might then fail.

(17) Install the manual shaft/rooster comb and transmission range sensor to the valve body (Fig. 153).

(18) Install the TRS/manual shaft retaining screw (Fig. 154) and torque to 5 N·m (45 in. lbs.).

(19) Install manual shaft seal.

DISASSEMBLY AND ASSEMBLY (Continued)

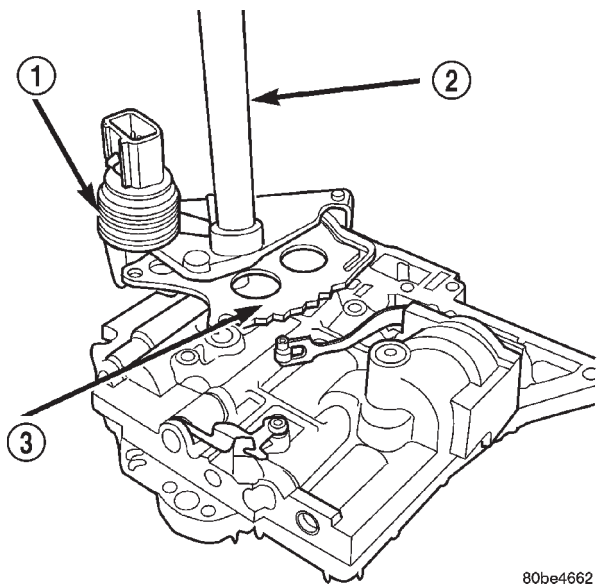

80be4662

Fig. 153 Manual Shaft/Rooster Comb and Transmission Range Sensor

- 1 - TRANSMISSION RANGE SENSOR
- 2 - MANUAL SHAFT
- 3 - ROOSTER COMB

End play specifications are .13 to .64 mm (.005 to .025 inch). Record indicator reading for reference when reassembling the transaxle.

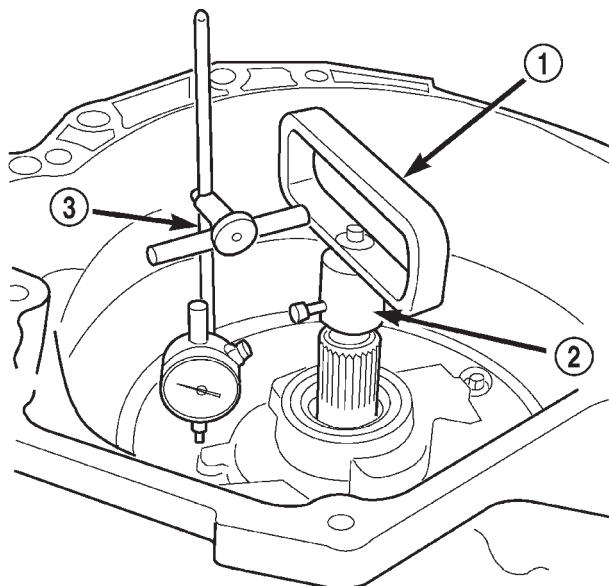

80bcd18

Fig. 155 Measure Input Shaft End Play Using Tool 8266—Typical

- 1 - TOOL 8266-8
- 2 - TOOL 8266-2
- 3 - TOOL C-3339

Remove both speed sensors from transaxle case (Fig. 156).

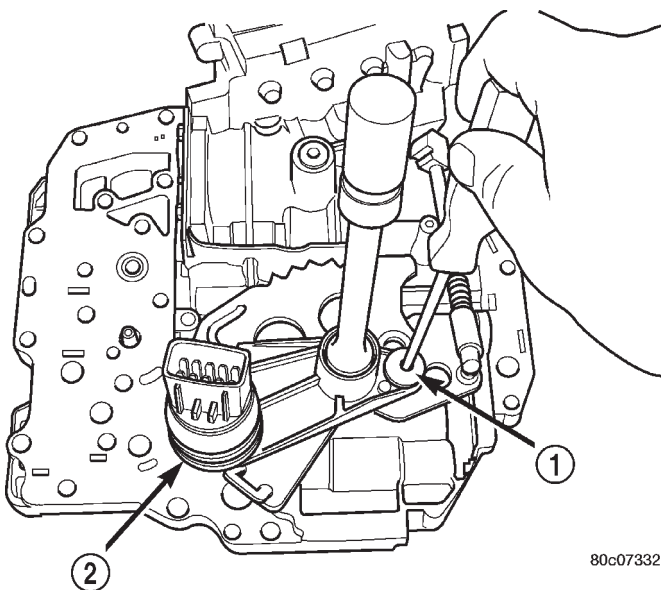

80c07332

Fig. 154 TRS/Manual Shaft Retaining Screw

- 1 - SCREW
- 2 - TRS

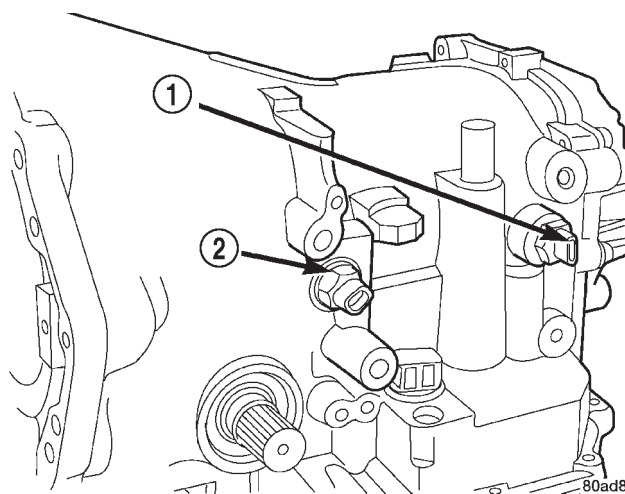

80ad8405

Fig. 156 Remove Input and Output Speed Sensor

- 1 - OUTPUT SPEED SENSOR
- 2 - INPUT SPEED SENSOR

Measuring input shaft end play before disassembly will usually indicate when a #4 thrust plate change is required. The number 4 thrust plate is located behind the overdrive clutch hub. Attach a dial indicator to transaxle bell housing with its plunger seated against end of input shaft (Fig. 155). Move input shaft in and out to obtain end play reading.

CAUTION: Do not handle the valve body by the manual shaft. Damage could result.

DISASSEMBLY AND ASSEMBLY (Continued)

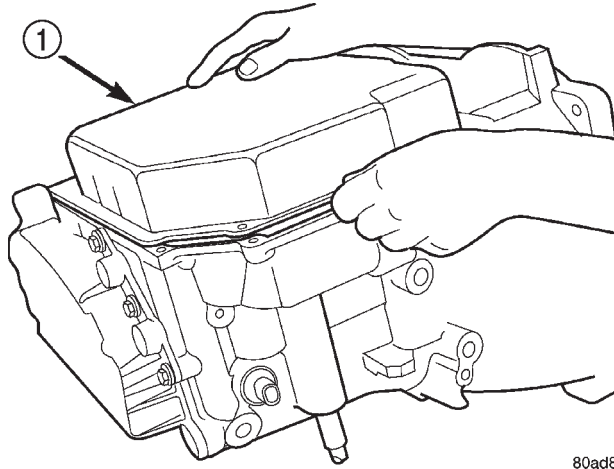

80ad8403

Fig. 157 Remove Transaxle Oil Pan

1 - TRANSAXLE OIL PAN

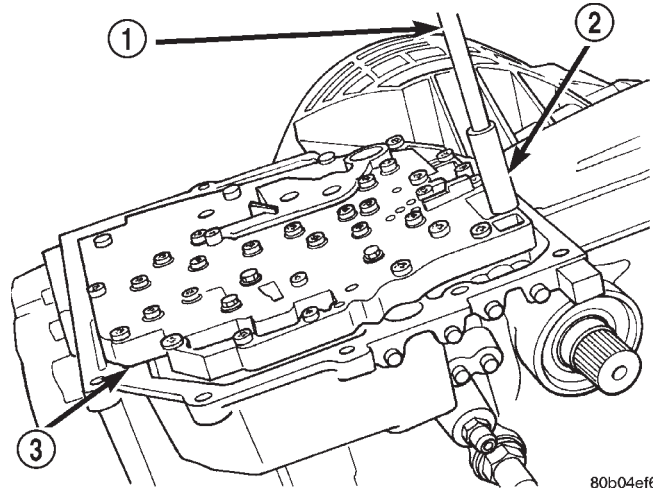

80b04ef6

Fig. 159 Remove Valve Body Bolts (17)

1 - EXTENSION
2 - SOCKET
3 - VALVE BODY

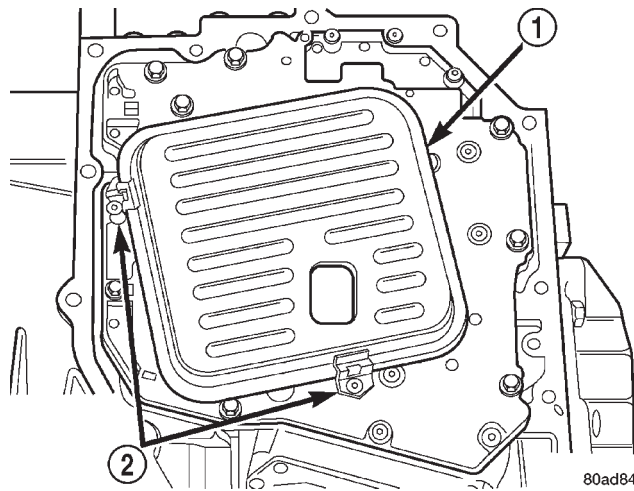

80ad8404

Fig. 158 Remove Transaxle Oil Filter

1 - TRANSAXLE FILTER
2 - FILTER RETAINING CLIPS

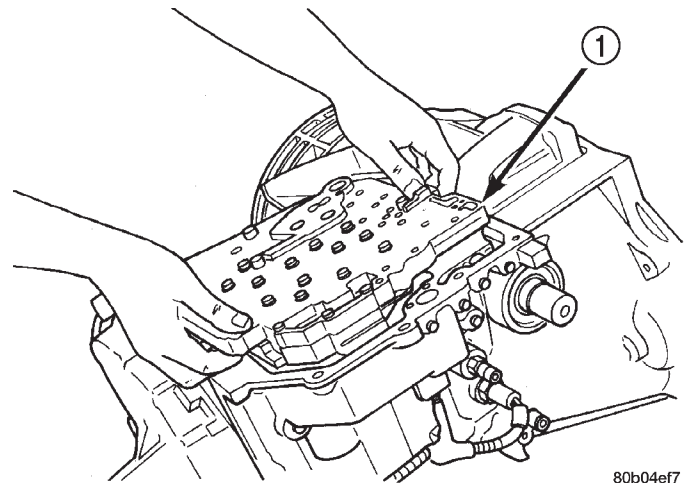

80b04ef7

Fig. 160 Remove Valve Body From Transaxle

1 - VALVE BODY

NOTE: For valve body recondition procedure, refer to Valve Body in this section.

DISASSEMBLY AND ASSEMBLY (Continued)

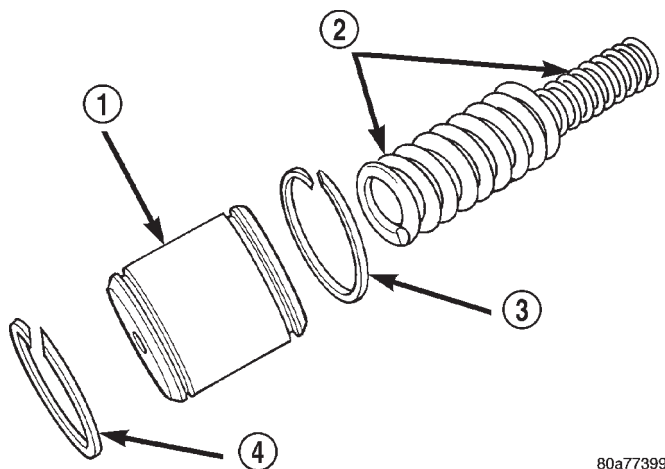

80a77399

Fig. 161 Remove Underdrive Accumulator and Spring

- 1 - ACCUMULATOR PISTON (UNDERDRIVE)
- 2 - RETURN SPRINGS
- 3 - SEAL RING
- 4 - SEAL RING

CAUTION: Tag the springs for the Overdrive Accumulator so that they are not confused with the springs in the Low/Reverse Accumulator.

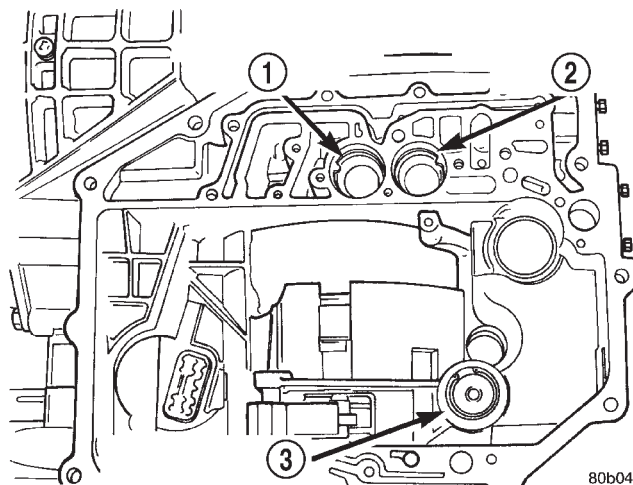

80b04ef8

Fig. 163 Accumulator Locations

- 1 - OVERDRIVE ACCUMULATOR LOCATION
- 2 - UNDERDRIVE ACCUMULATOR LOCATION
- 3 - LOW/REVERSE ACCUMULATOR

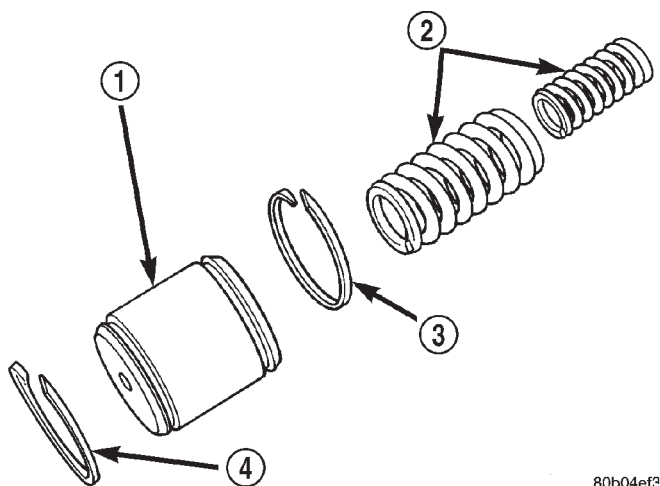

80b04ef3

Fig. 162 Remove Overdrive Accumulator and Springs

- 1 - OVERDRIVE ACCUMULATOR PISTON
- 2 - RETURN SPRINGS
- 3 - SEAL RING
- 4 - SEAL RING

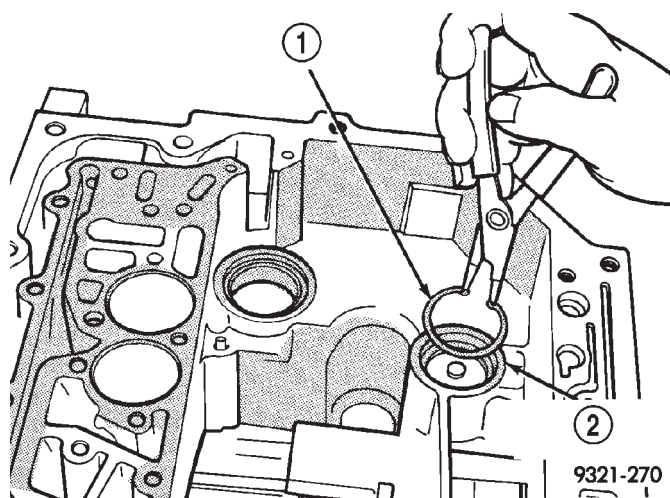

9321-270

Fig. 164 Remove Low/Reverse Accumulator

- 1 - SNAP RING
- 2 - LOW/REVERSE ACCUMULATOR

DISASSEMBLY AND ASSEMBLY (Continued)

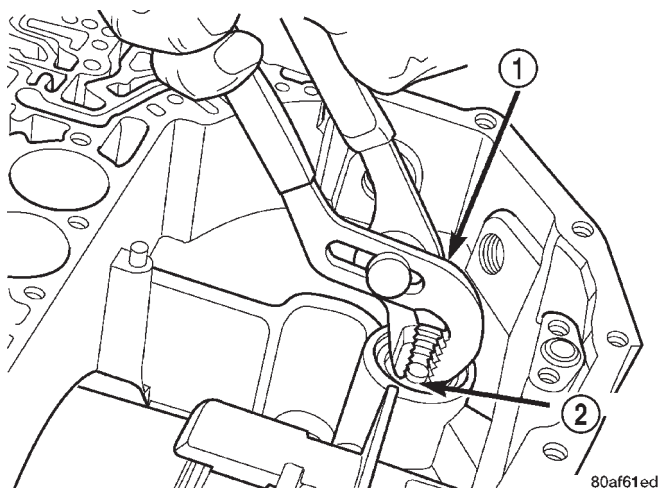

80af61ed

Fig. 165 Remove Low/Reverse Accumulator Plug (Cover)

- 1 - ADJUSTABLE PLIERS
- 2 - PLUG

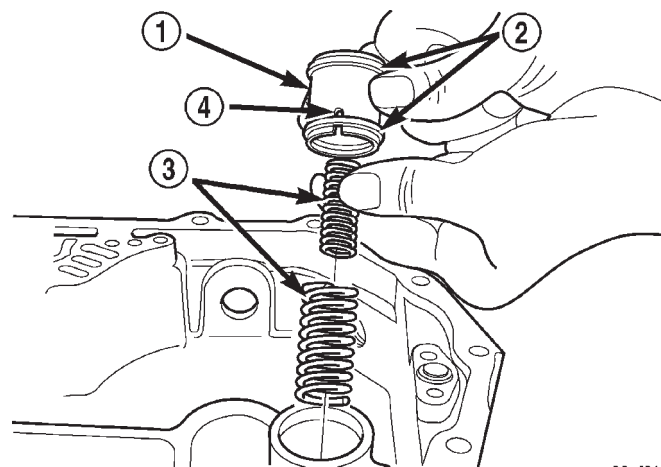

80af61ef

Fig. 167 Low/Reverse Accumulator

- 1 - ACCUMULATOR PISTON
- 2 - SEAL RINGS
- 3 - RETURN SPRINGS
- 4 - (NOTE NOTCH)

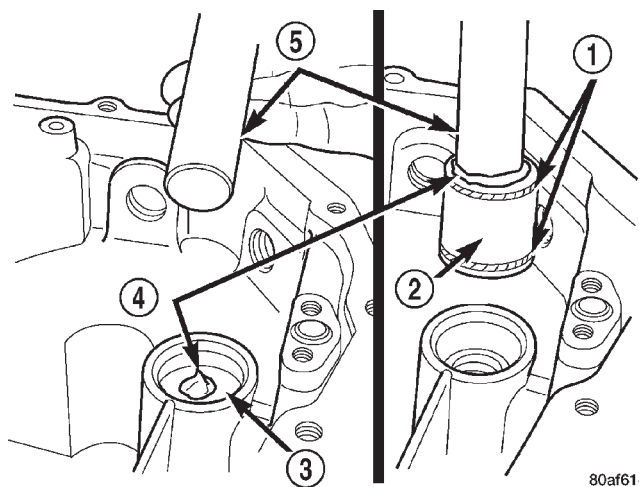

80af61ee

Fig. 166 Remove Low/Reverse Accumulator Piston

- 1 - SEAL RINGS
- 2 - PISTON
- 3 - PISTON
- 4 - PETROLATUM
- 5 - SUITABLE TOOL

NOTE: Remove driveshaft retainer clips from drive-shafts.

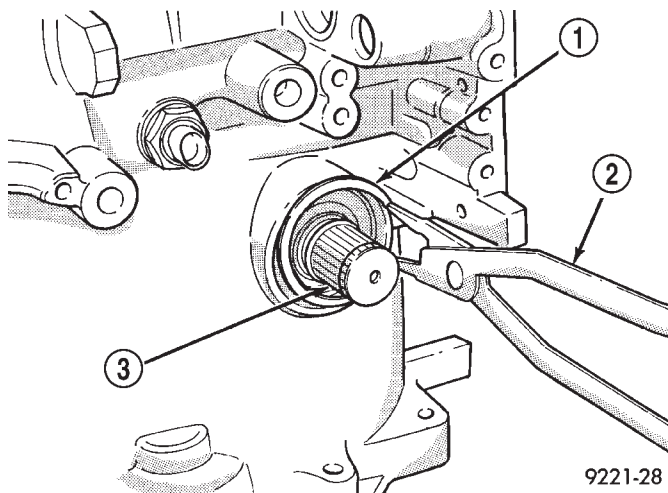

9221-28

Fig. 168 Remove Long Stub Shaft Snap Ring

- 1 - SNAP RING
- 2 - SNAP RING PLIERS
- 3 - LONG STUB SHAFT

DISASSEMBLY AND ASSEMBLY (Continued)

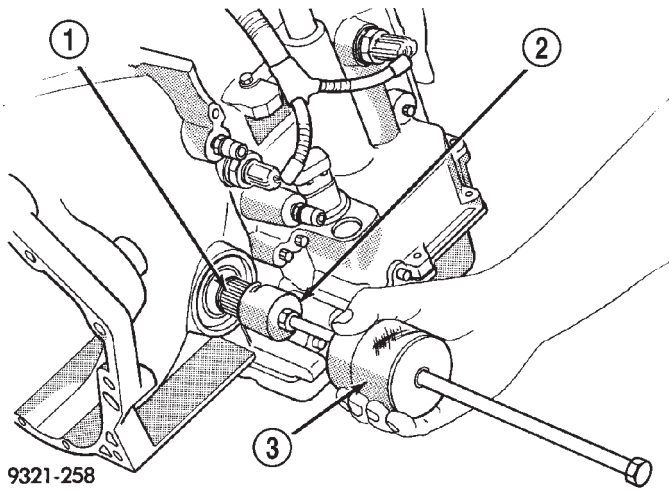

Fig. 169 Remove Long Stub Shaft From Bellhousing

- 1 - LONG STUB SHAFT
- 2 - SPECIAL TOOL 6669
- 3 - SLIDE HAMMER C-3752

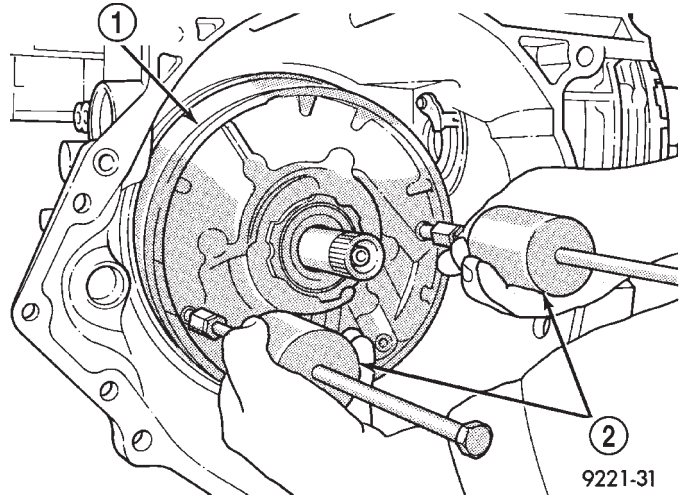

Fig. 171 Oil Pump Pullers

- 1 - OIL PUMP
- 2 - PULLERS

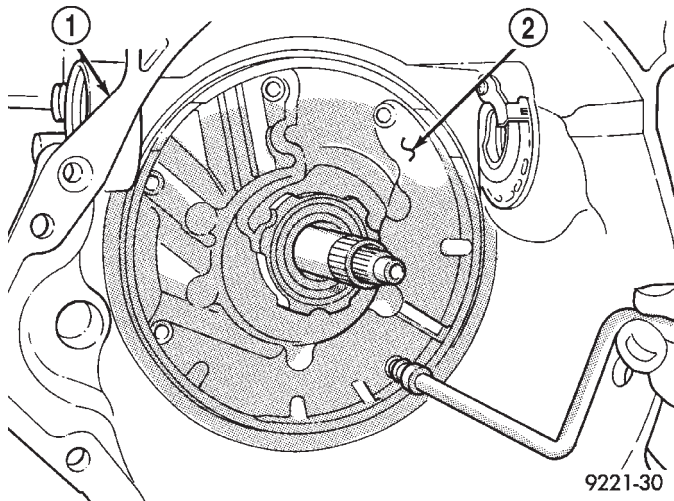

Fig. 170 Remove Oil Pump Attaching Bolts

- 1 - BELLHOUSING
- 2 - OIL PUMP

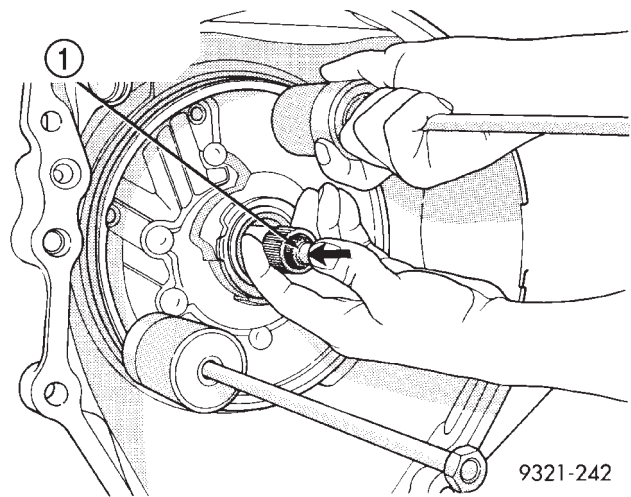

Fig. 172 Remove Oil Pump

- 1 - "PUSH IN" ON INPUT SHAFT WHILE REMOVING PUMP

NOTE: To align oil pump during installation, use threaded dowels or phillips screwdrivers.

DISASSEMBLY AND ASSEMBLY (Continued)

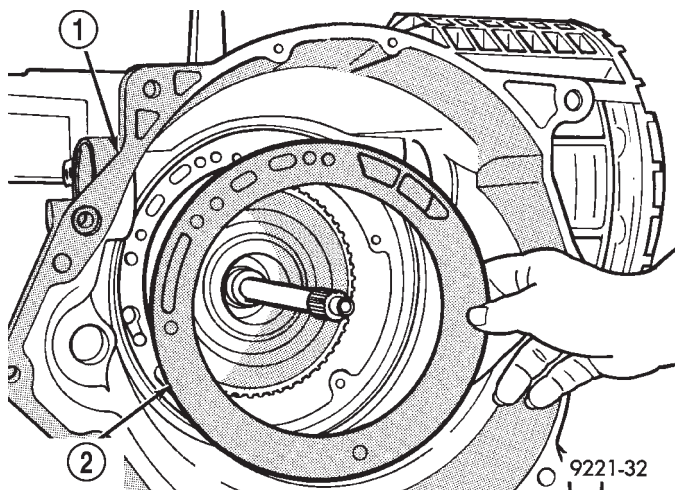

Fig. 173 Remove Oil Pump Gasket

- 1 - BELL HOUSING
- 2 - OIL PUMP GASKET

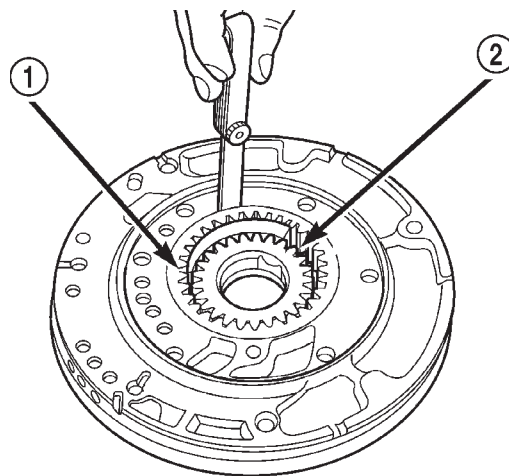

Fig. 175 Measure Outer Gear to Pocket

- 1 - OUTER GEAR
- 2 - POCKET

OIL PUMP INSPECTION

When disassembling the transaxle it is necessary to inspect the oil pump for wear and damage.

- (1) Remove the reaction shaft support bolts.
- (2) Remove reaction shaft support from pump housing (Fig. 174).

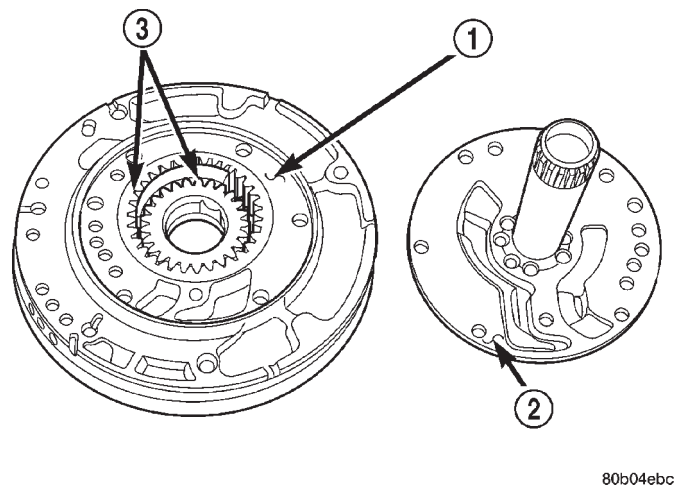

Fig. 174 Reaction Shaft Support

- 1 - PUMP HOUSING
- 2 - REACTION SHAFT SUPPORT
- 3 - PUMP GEARS

(3) Remove the pump gears and check for wear and damage.

(4) Install the gears and check clearances.

(5) Measure the clearance between the outer gear and the pump pocket (Fig. 175). Clearance should be 0.045-0.141mm (0.0018-0.0056 in.)

(6) Position an appropriate piece of Plastigage across both pump gears.

(7) Align the Plastigage to a flat area on the reaction shaft support housing.

(8) Install the reaction shaft to the pump housing. Tighten the bolts to 27 N. M (20 ft. lbs.)

(9) Remove bolts and carefully separate the housings. Measure the Plastigage following the instructions supplied.

(10) Clearance between outer gear side and the reaction shaft support should be 0.020-0.046mm (0.008-0.0018 in.). Clearance between inner gear side and the reaction shaft support should be 0.020-0.046mm (0.008-0.0018 in.).

CAUTION: By-pass valve must be replaced if transmission failure occurs.

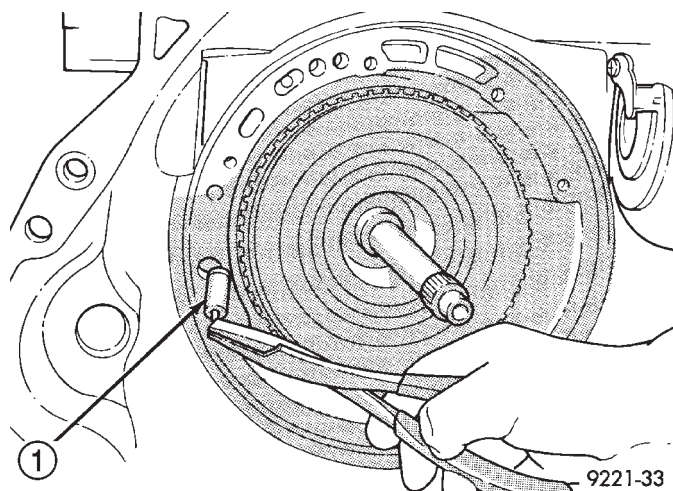
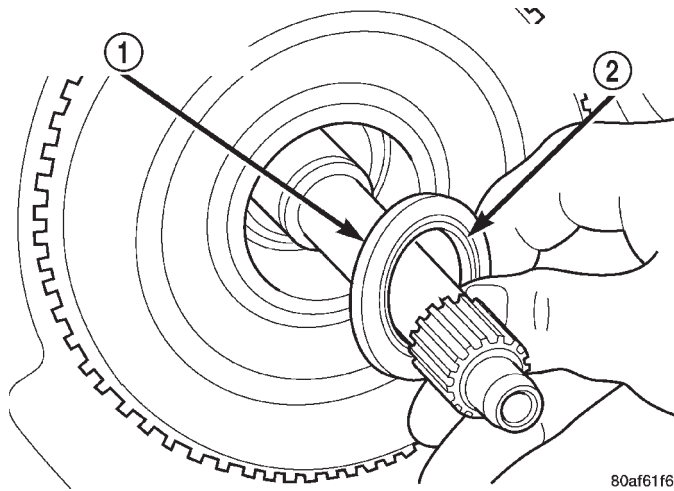

Fig. 176 Remove By-Pass Valve

- 1 - BY-PASS VALVE

DISASSEMBLY AND ASSEMBLY (Continued)



80af61f6

Fig. 177 Remove No. 1 Caged Needle Bearing

- 1 - #1 CAGED NEEDLE BEARING
- 2 - NOTE: TANGED SIDE OUT

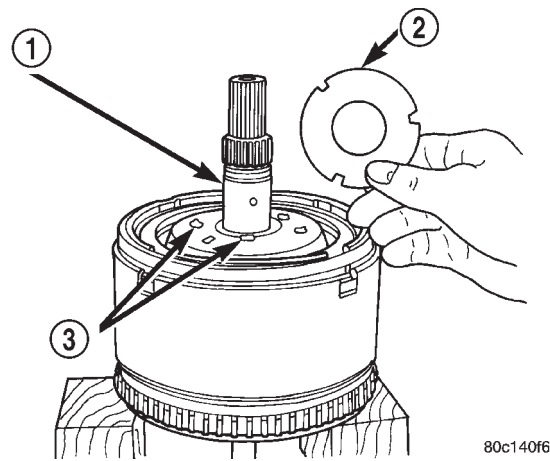

80c140f6

Fig. 179 Remove No. 4 Thrust Plate

- 1 - OVERDRIVE SHAFT ASSEMBLY
- 2 - #4 THRUST PLATE (SELECT)
- 3 - 3 DABS OF PETROLATUM FOR RETENTION

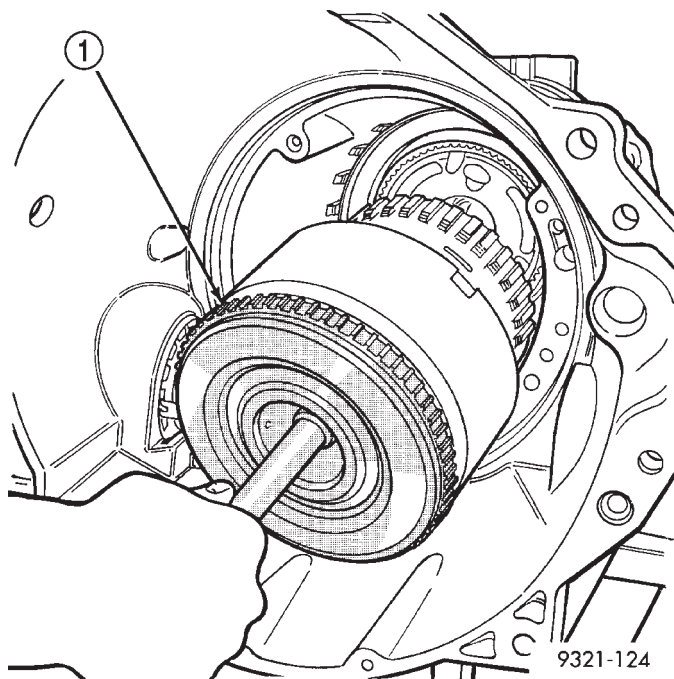

9321-124

Fig. 178 Remove Input Clutch Assembly

- 1 - INPUT CLUTCH ASSEMBLY

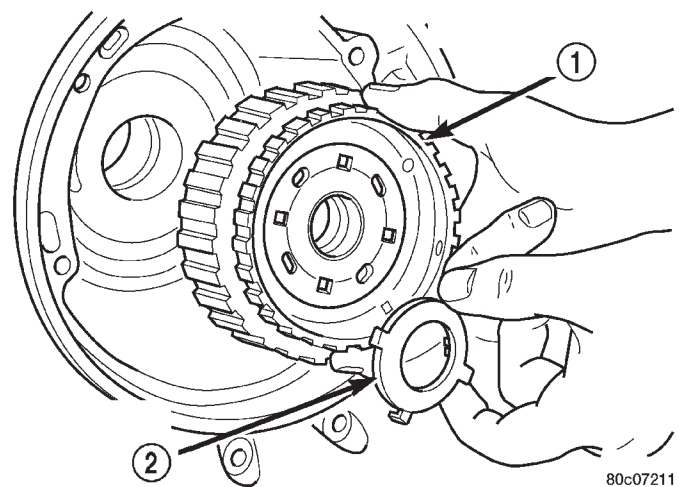

80c07211

Fig. 180 Remove Front Sun Gear Assembly

- 1 - FRONT SUN GEAR ASSEMBLY
- 2 - #4 THRUST WASHER (FOUR TABS)

DISASSEMBLY AND ASSEMBLY (Continued)

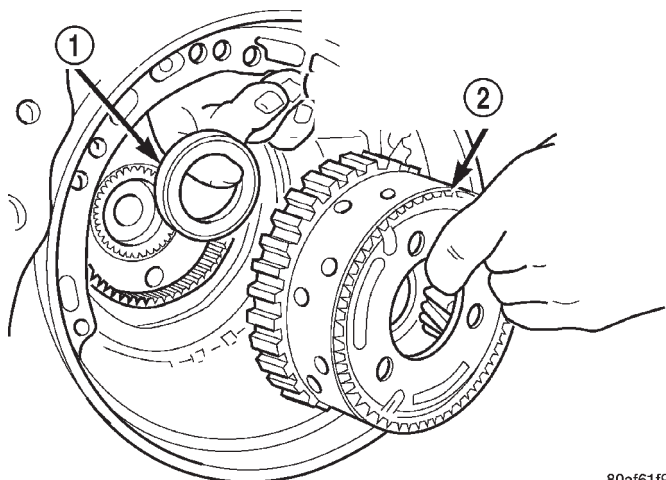

80af61f9

Fig. 181 Remove Front Carrier and Rear Annulus Assembly

- 1 - #6 NEEDLE BEARING
- 2 - FRONT CARRIER AND REAR ANNULUS ASSEMBLY (TWIST AND PULL OR PUSH TO REMOVE OR INSTALL).

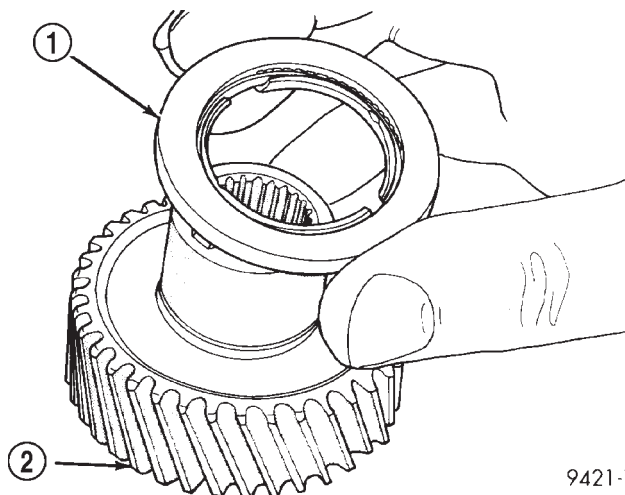

9421-71

Fig. 183 Number 7 Bearing

- 1 - #7 BEARING
- 2 - REAR SUN GEAR

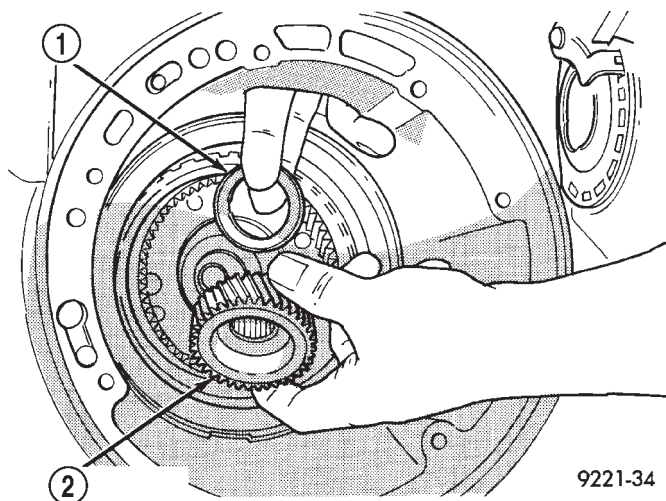

9221-34

Fig. 182 Remove Rear Sun Gear

- 1 - #7 NEEDLE BEARING
- 2 - REAR SUN GEAR

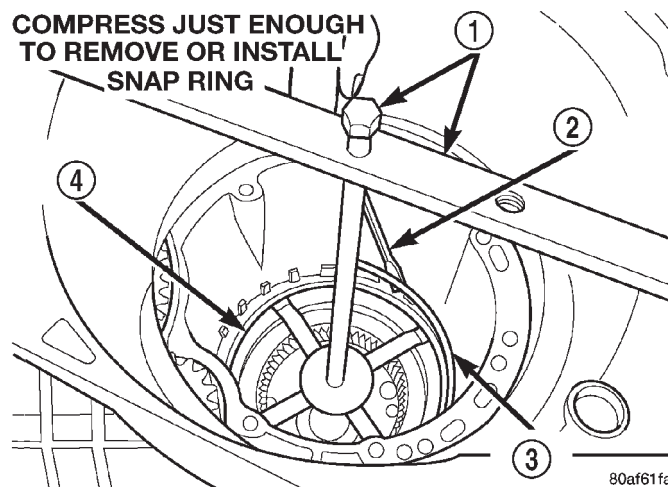

80af61fa

COMPRESS JUST ENOUGH TO REMOVE OR INSTALL!
SNAP RING

Fig. 184 Remove 2/4 Clutch Retainer Snap Ring

- 1 - TOOL 5058
- 2 - SCREWDRIVER
- 3 - SNAP RING
- 4 - 2/4 CLUTCH RETAINER

The number seven needle bearing has three antireversal tabs and is common with the number five and number two position. The orientation should allow the bearing to seat flat against the rear sun gear (Fig. 183). A small amount of petrolatum can be used to hold the bearing to the rear sun gear.

Stand trans upright on bellhousing.
Chain cover must be free of old sealant, dirt and oil before applying new sealant. Apply a 1/8 inch bead of sealant to flange of cover.

DISASSEMBLY AND ASSEMBLY (Continued)

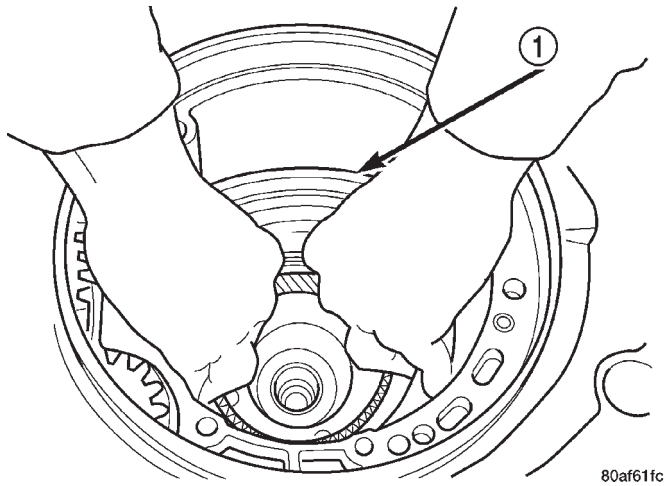

80af61fc

Fig. 185 Remove 2/4 Clutch Retainer

1 - 2/4 CLUTCH RETAINER

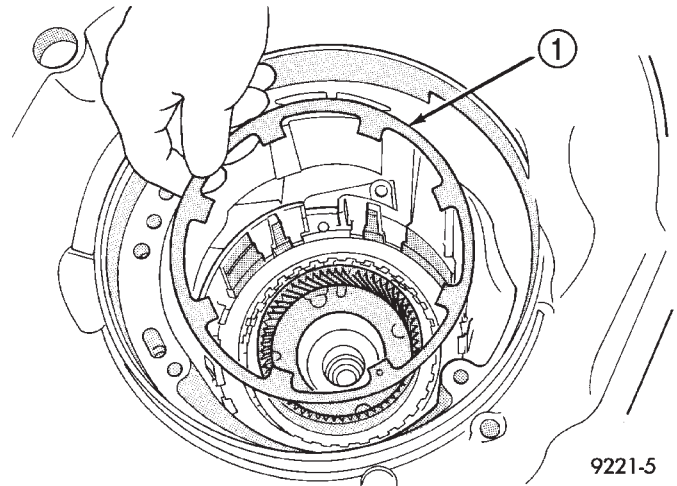

9221-5

Fig. 187 Remove 2/4 Clutch Return Spring

1 - 2/4 CLUTCH RETURN SPRING

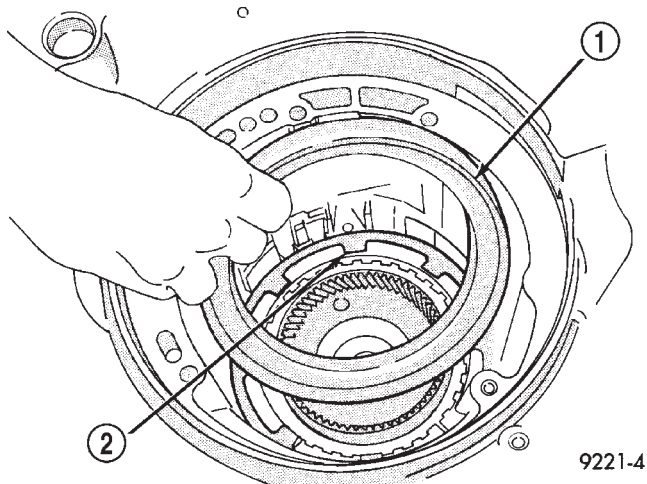

9221-4

Fig. 186 2/4 Clutch Retainer

1 - 2/4 CLUTCH RETAINER
2 - 2/4 CLUTCH RETURN SPRING

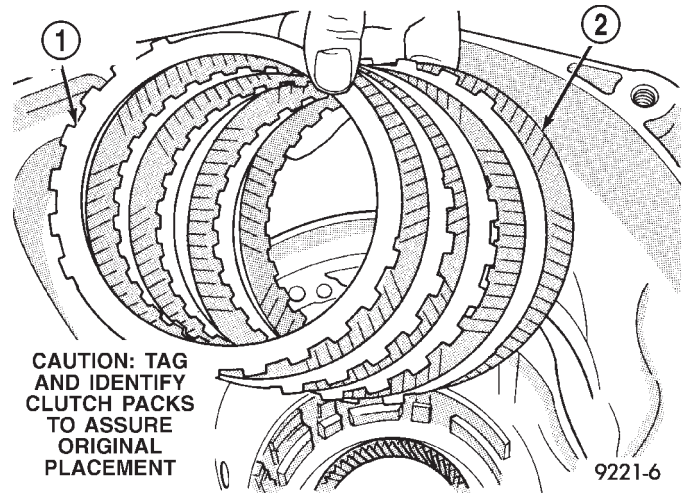

9221-6

CAUTION: TAG AND IDENTIFY CLUTCH PACKS TO ASSURE ORIGINAL PLACEMENT

Fig. 188 Remove 2/4 Clutch Pack

1 - CLUTCH PLATE (4)
2 - CLUTCH DISC (4)

DISASSEMBLY AND ASSEMBLY (Continued)

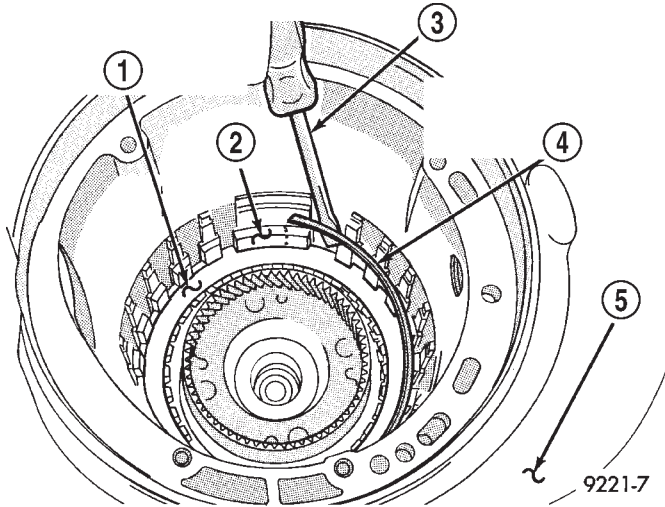

Fig. 189 Remove Tapered Snap Ring

- 1 - LOW/REVERSE CLUTCH REACTION PLATE
- 2 - LONG TAB
- 3 - SCREWDRIVER
- 4 - LOW/REVERSE TAPERED SNAP RING (TAPERED SIDE UP)
- 5 - OIL PAN FACE

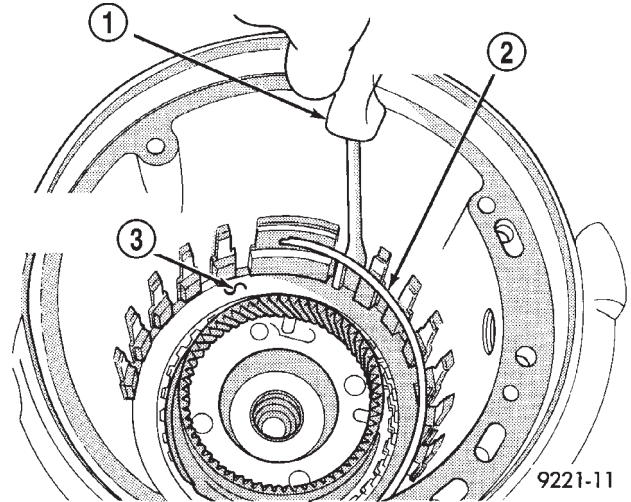

Fig. 191 Remove Low/Reverse Reaction Plate Snap Ring

- 1 - SCREWDRIVER
- 2 - LOW/REVERSE REACTION PLATE FLAT SNAP RING
- 3 - DO NOT SCRATCH CLUTCH PLATE

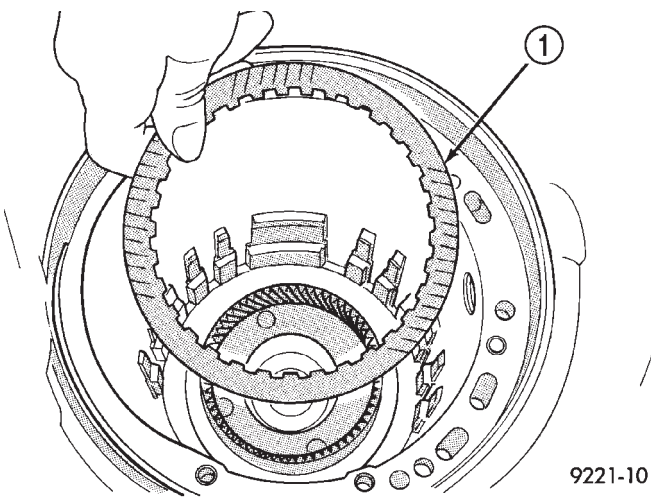

Fig. 190 Remove One Disc

- 1 - ONE DISC FROM LOW/REVERSE CLUTCH

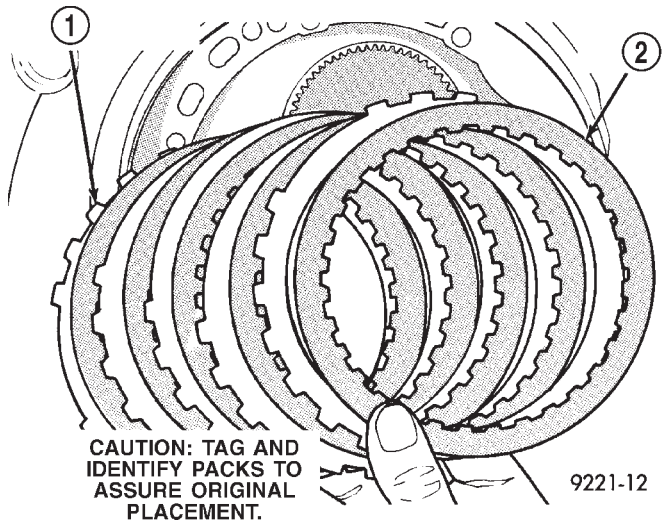
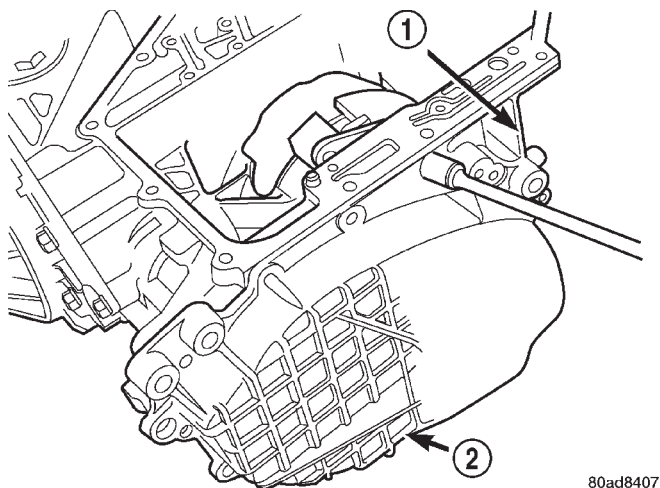

Fig. 192 Remove Low/Reverse Clutch Pack

- 1 - CLUTCH PLATES (5)
- 2 - CLUTCH DISCS (5)

DISASSEMBLY AND ASSEMBLY (Continued)



80ad8407

Fig. 193 Remove Chain Cover

- 1 - TRANSAXLE CASE
- 2 - CHAIN COVER

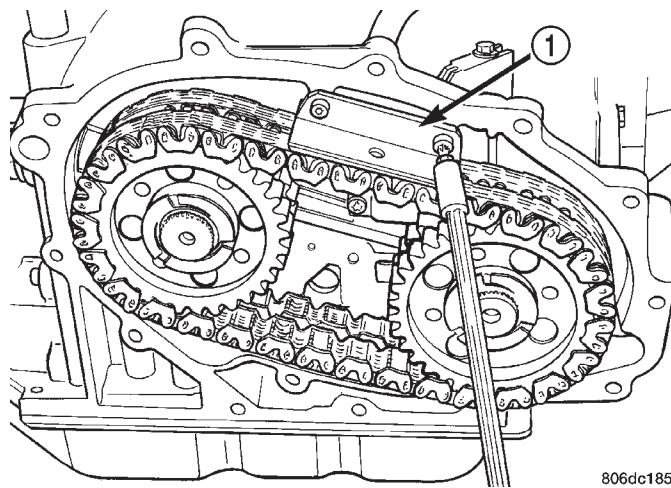

806dc185

Fig. 195 Remove Chain Snubber

- 1 - CHAIN SNUBBER

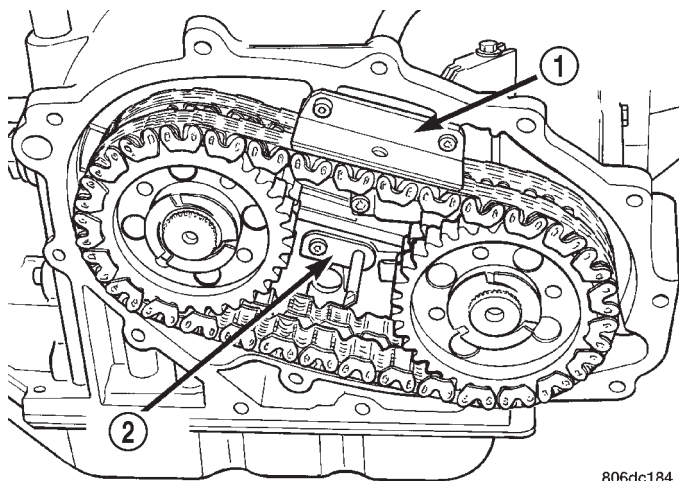

806dc184

Fig. 194 Remove Chain Oiler

- 1 - CHAIN SNUBBER
- 2 - CHAIN OILER

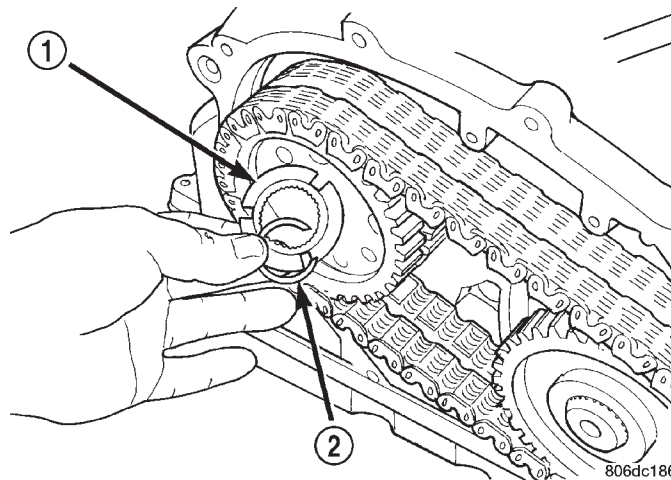

806dc186

Fig. 196 Remove Output Shaft Sprocket Snap Ring and Wave Washer

- 1 - WAVE WASHER
- 2 - SNAP RING

CAUTION: Be sure to reinstall the chain snubber and chain oiler when reassembling.

DISASSEMBLY AND ASSEMBLY (Continued)

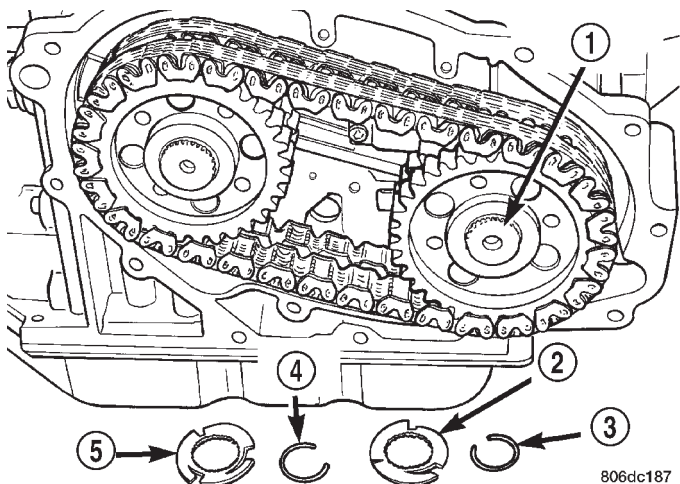

Fig. 197 Remove Transfer Shaft Sprocket Snap Ring and Wave Washer

- 1 - TRANSFER SHAFT
- 2 - WAVE WASHER
- 3 - SNAP RING
- 4 - SNAP RING
- 5 - WAVE WASHER

CAUTION: The chain sprockets have a slip fit onto the shafts. Apply only a slight amount of pressure to the chain spreader to release the chain pressure. If chain sprockets are not spread slightly, removal or installation will be difficult. Overspreading of the chain sprockets will also make sprocket removal difficult.

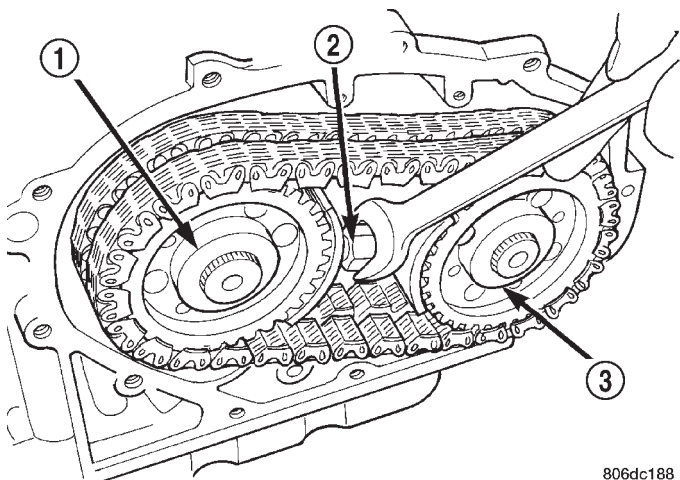

Fig. 198 Install Chain Spreader

- 1 - OUTPUT SPROCKET
- 2 - SPECIAL TOOL 6550
- 3 - TRANSFER SPROCKET

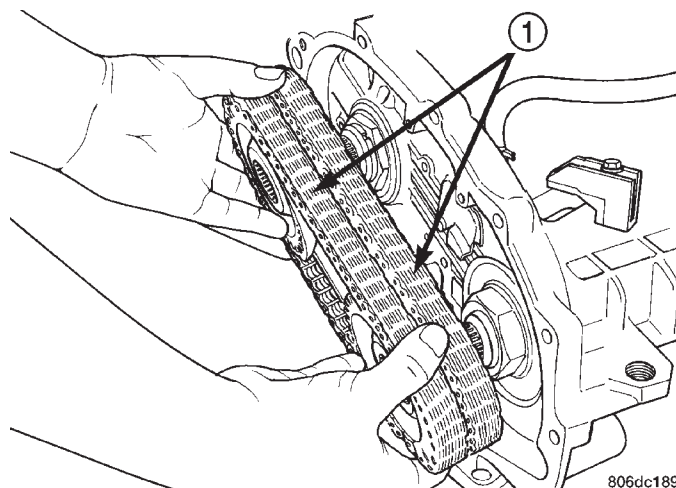

Fig. 199 Remove Chains and Both Sprockets as an Assembly

- 1 - CHAINS

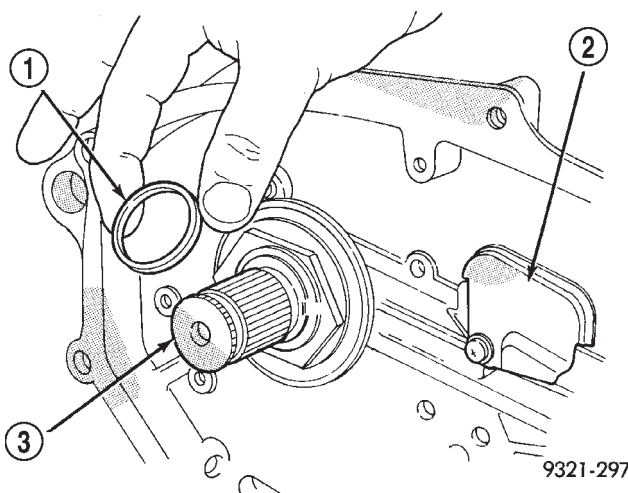

Fig. 200 Output Sprocket Spacer

- 1 - OUTPUT SPROCKET SPACER
- 2 - VENT BAFFLE
- 3 - OUTPUT SHAFT

Remove main sump baffle from transaxle case (Fig. 201).

CAUTION: Failure to grind and open stakes of the output shaft nut and transfer shaft nut will result in thread damage to the shafts during nut removal.

WARNING: WEAR SAFETY GOGGLES WHILE GRINDING STAKE NUTS.

DISASSEMBLY AND ASSEMBLY (Continued)

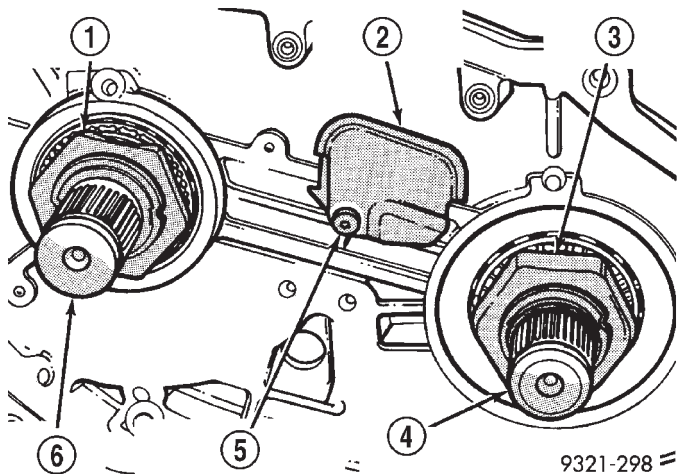

Fig. 201 Main Sump Vent Baffle Location

- 1 - OUTPUT SHAFT NUT
- 2 - MAIN SUMP VENT BAFFLE
- 3 - TRANSFER SHAFT NUT
- 4 - TRANSFER SHAFT
- 5 - VENT BAFFLE RETAINING SCREW
- 6 - OUTPUT SHAFT

Using a die grinder or equivalent, grind the stakes in the shoulder of the shaft nuts as shown in (Fig. 202) and (Fig. 203). Do not grind all the way through the nut and into the shaft. There are two stakes on each nut.

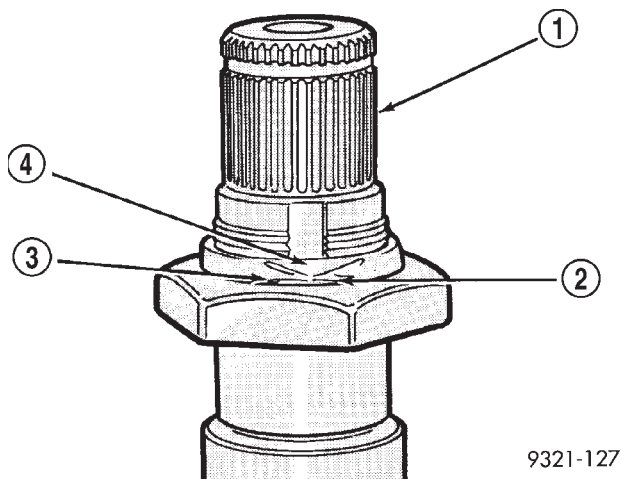

Fig. 202 Grinding Stakes

- 1 - TRANSFER SHAFT
- 2 - GRIND HERE
- 3 - GRIND HERE
- 4 - NUT STAKE

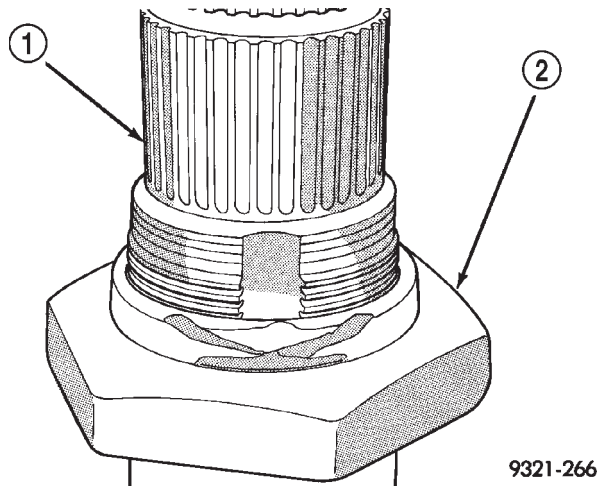

Fig. 203 Stake Grinding Pattern

- 1 - TRANSFER SHAFT
- 2 - TRANSFER SHAFT NUT

Using a small chisel, carefully open stakes on nut (Fig. 204).

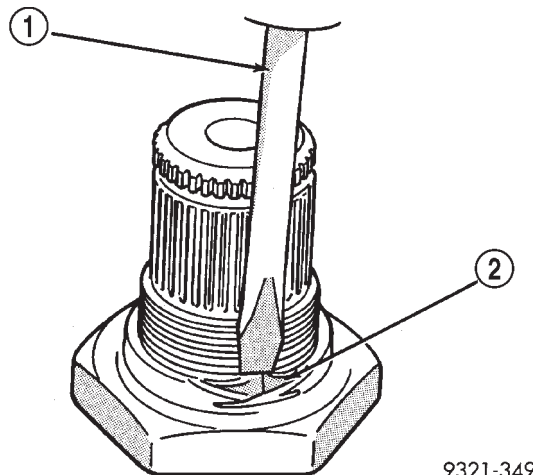

Fig. 204 Opening Nut Stakes

- 1 - CHISEL
- 2 - NUT STAKE

Use special tool 6497 and 6498 to remove the transfer shaft nut or the output shaft nut (Fig. 205). Note that your breaker bar will turn clockwise to remove the nut and counter clockwise to install the nut.

Use special tool 6596 to remove front output shaft bearing cup (Fig. 207).

DISASSEMBLY AND ASSEMBLY (Continued)

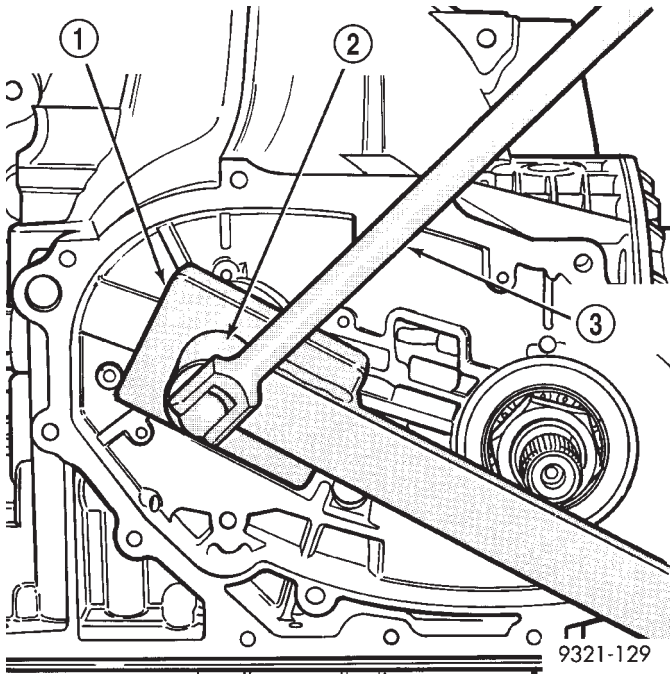

Fig. 205 Remove Output Shaft Nut

- 1 - SPECIAL TOOL 6497
- 2 - SPECIAL TOOL 6498
- 3 - BREAKER BAR

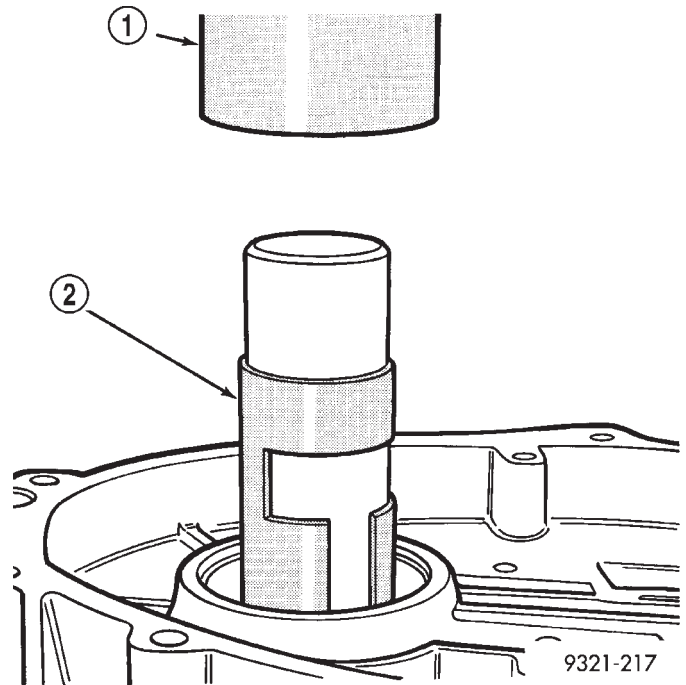

Fig. 207 Remove Front Bearing Cup

- 1 - ARBOR PRESS
- 2 - SPECIAL TOOL 6596

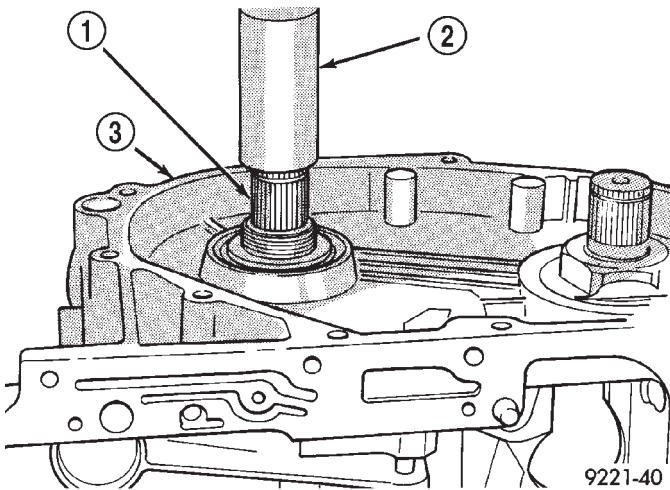

Fig. 206 Use Arbor Press to Remove Output Shaft from Case

- 1 - OUTPUT SHAFT
- 2 - ARBOR PRESS
- 3 - TRANSAXLE CASE

Use special tool 6597 and handle C-4171 and C-4171-2 to press rear output shaft bearing cup rearward (Fig. 208).

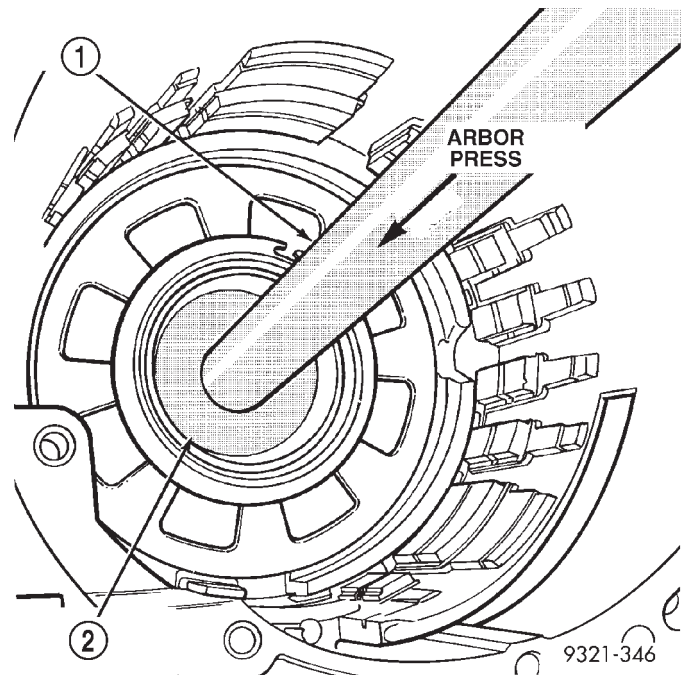

Fig. 208 Remove Rear Bearing Cup

- 1 - SPECIAL TOOL 4171 AND 4171-2
- 2 - SPECIAL TOOL 6597

DISASSEMBLY AND ASSEMBLY (Continued)

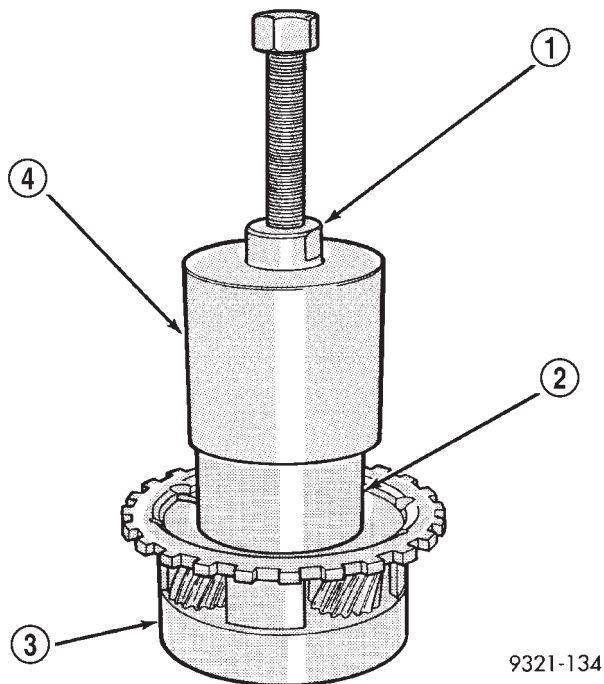

Fig. 209 Remove Rear Carrier Front Bearing Cone

- 1 - SPECIAL TOOL 5048-1
- 2 - SPECIAL TOOL 6545
- 3 - REAR CARRIER
- 4 - SPECIAL TOOL 5048

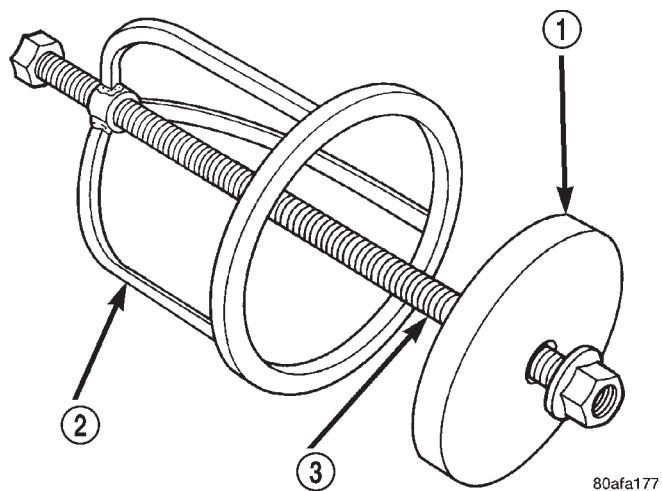

Fig. 210 Low/Reverse Spring Compressor Tool

- 1 - TOOL 6057
- 2 - TOOL 5059
- 3 - TOOL 5058-3

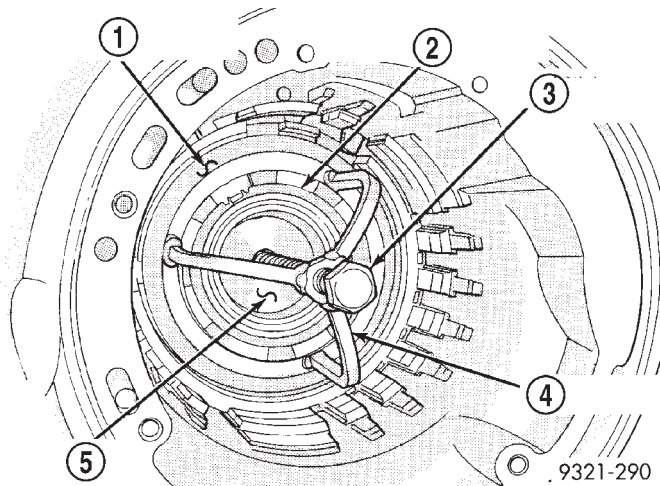

Fig. 211 Compressor Tool in Use

- 1 - LOW/REVERSE CLUTCH RETURN SPRING
- 2 - SNAP RING (INSTALL AS SHOWN)
- 3 - TOOL 5058A-3
- 4 - TOOL 5059A
- 5 - SPECIAL TOOL 6057

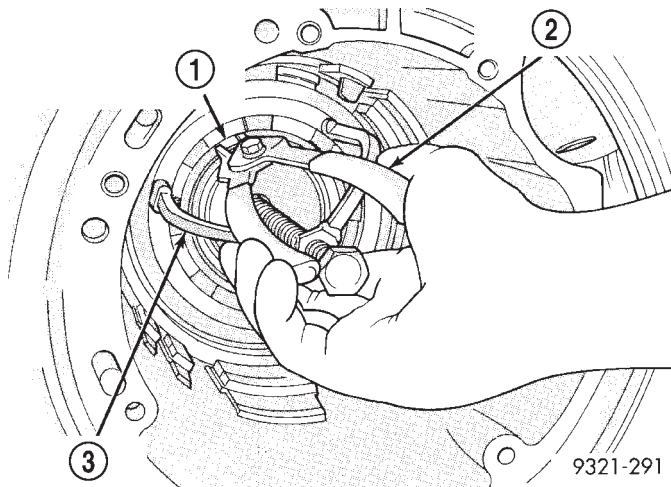

Fig. 212 Remove Snap Ring

- 1 - SNAP RING OPENING MUST BE BETWEEN SPRING LEVERS (AS SHOWN)
- 2 - SNAP RING PLIERS
- 3 - SPECIAL TOOL 5059A

DISASSEMBLY AND ASSEMBLY (Continued)

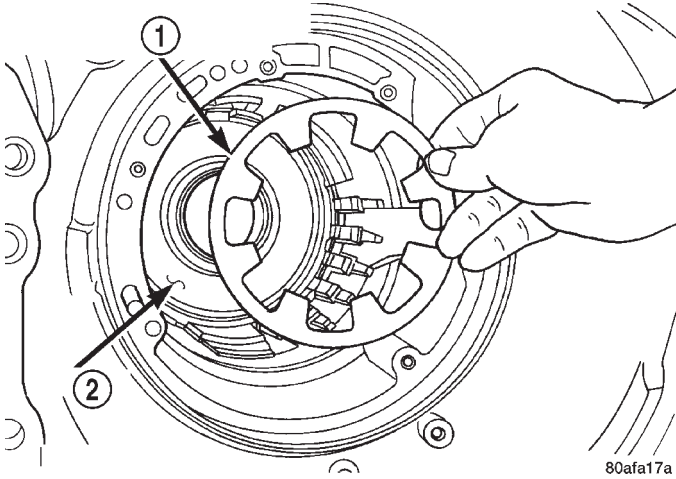

Fig. 213 Low/Reverse Piston Return Spring

- 1 - LOW/REVERSE PISTON RETURN SPRING
- 2 - PISTON

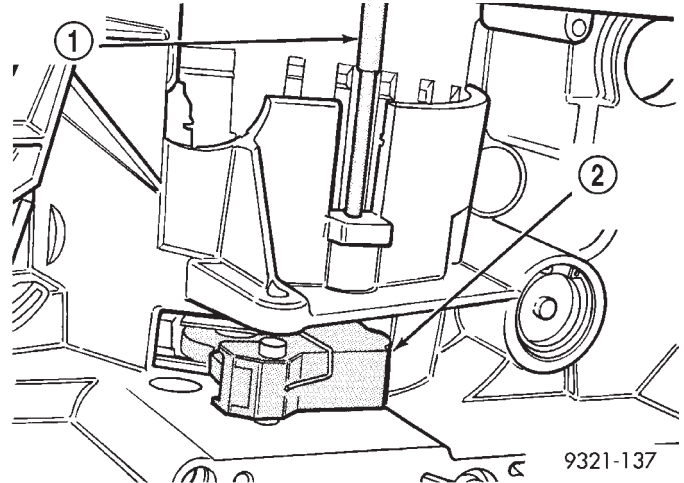

Fig. 215 Anchor Shaft Removal

- 1 - PIN PUNCH
- 2 - GUIDE BRACKET ASSEMBLY

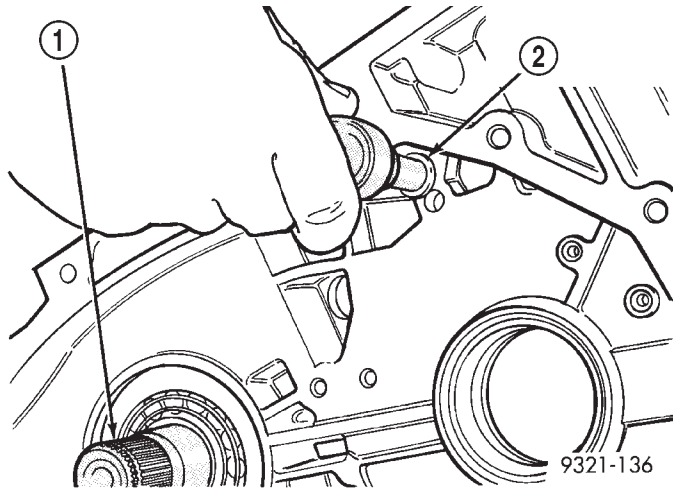

Fig. 214 Remove Parking Sprag Pivot Retaining Screw

- 1 - TRANSFER SHAFT
- 2 - PARKING SPRAG PIVOT RETAINING SCREW

NOTE: Using a pin punch, drive out guide bracket pivot shaft.

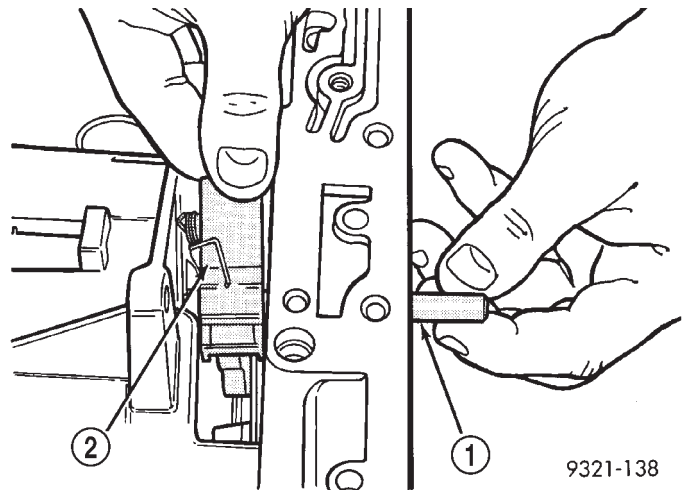

Fig. 216 Guide Bracket Pivot Shaft

- 1 - PIVOT PIN
- 2 - GUIDE BRACKET ASSEMBLY

DISASSEMBLY AND ASSEMBLY (Continued)

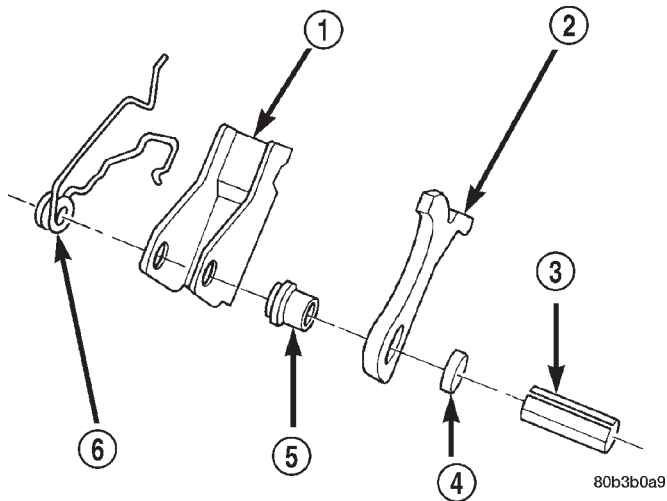

Fig. 217 Guide Bracket Disassembled

- 1 - GUIDE BRACKET
- 2 - PAWL
- 3 - SPLIT SLEEVE
- 4 - SPACER
- 5 - STEPPED SPACER
- 6 - ANTIRATCHET SPRING

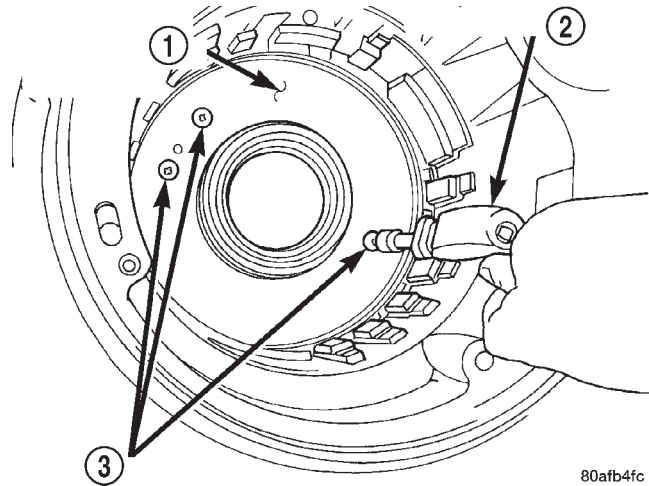

Fig. 219 Remove Piston Retainer Attaching Screws

- 1 - LOW/REVERSE CLUTCH PISTON RETAINER
- 2 - SCREWDRIVER
- 3 - TORX-LOC SCREWS

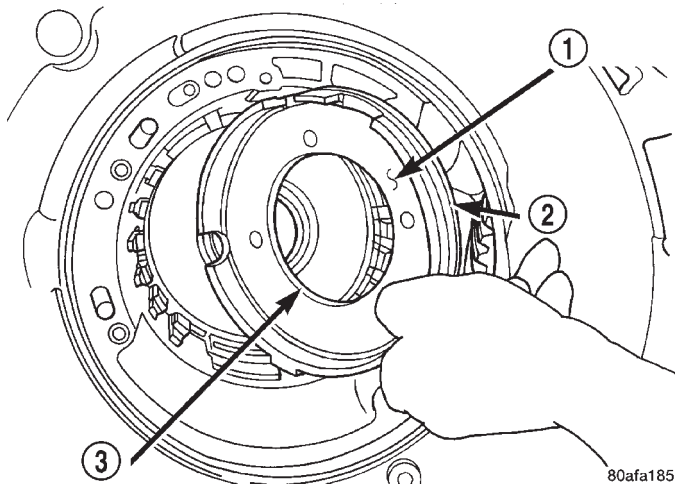

Fig. 218 Remove Low/Reverse Clutch Piston

- 1 - LOW/REVERSE CLUTCH PISTON
- 2 - LIP SEAL
- 3 - LIP SEAL

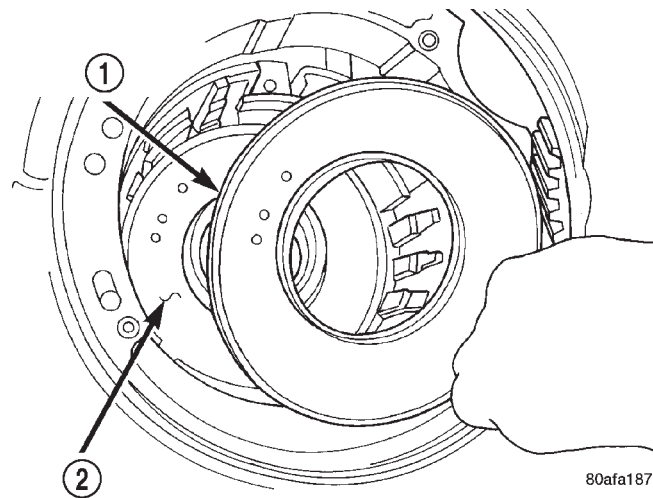
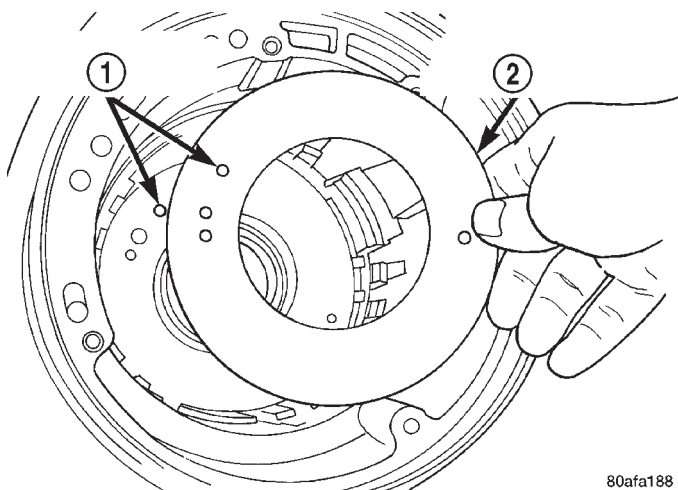

Fig. 220 Remove Piston Retainer

- 1 - LOW/REVERSE CLUTCH PISTON RETAINER
- 2 - GASKET

DISASSEMBLY AND ASSEMBLY (Continued)



80afa188

Fig. 221 Remove Piston Retainer Gasket

- 1 - GASKET HOLES MUST LINE UP
- 2 - LOW/REVERSE CLUTCH PISTON RETAINER GASKET

At this point the Centerline of the transaxle has been removed. If the condition for disassembly did not pertain to the differential, it's disassembly may not be required. Inspect the rear transfer shaft area and the transfer shaft seal area for contamination. If evidence of contamination is present, replace the rear transfer shaft bearing and/or the transfer shaft seal.

OIL PUMP

DISASSEMBLY, INSPECTION, & ASSEMBLY

When disassembling the transaxle it is necessary to inspect the oil pump for wear and damage.

- (1) Remove the reaction shaft support bolts.
- (2) Remove reaction shaft support from pump housing (Fig. 222).

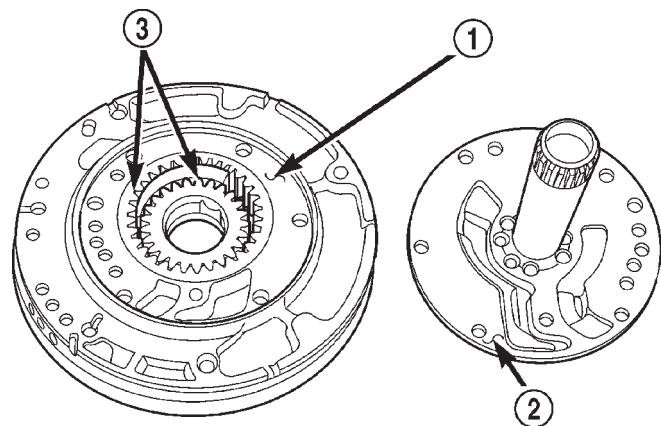

80b04ebc

Fig. 222 Reaction Shaft Support

- 1 - PUMP HOUSING
- 2 - REACTION SHAFT SUPPORT
- 3 - PUMP GEARS

- (3) Remove the pump gears (Fig. 223) and check for wear and damage.

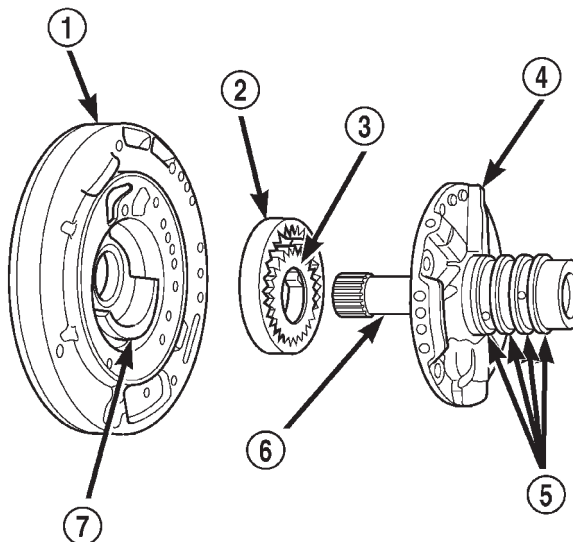

80be46c4

Fig. 223 Oil Pump Assembly

- 1 - PUMP HOUSING
- 2 - OUTER PUMP GEAR
- 3 - INNER PUMP GEAR
- 4 - REACTION SHAFT SUPPORT
- 5 - SEAL RINGS (4)
- 6 - REACTION SHAFT
- 7 - CRESCENT

- (4) Re-install the gears and check clearances.
- (5) Measure the clearance between the outer gear and the pump pocket (Fig. 224). Clearance should be 0.045-0.141mm (0.0018-0.0056 in.).

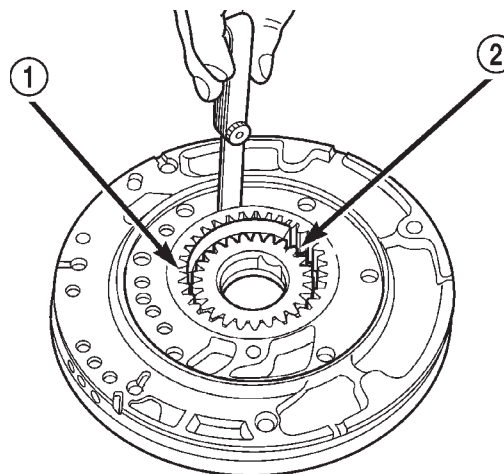

80b04ebb

Fig. 224 Measure Outer Gear to Pocket

- 1 - OUTER GEAR
- 2 - POCKET

DISASSEMBLY AND ASSEMBLY (Continued)

(6) Position an appropriate piece of Plastigage across both pump gears.

(7) Align the Plastigage to a flat area on the reaction shaft support housing.

(8) Install the reaction shaft to the pump housing. Tighten the bolts to 27 N·M (20 ft. lbs.).

(9) Remove bolts and carefully separate the housings. Measure the Plastigage following the instructions supplied.

(10) Clearance between outer gear side and the reaction shaft support should be 0.020-0.046 mm (0.008-0.0018 in.). Clearance between inner gear side and the reaction shaft support should be 0.020-0.046 mm (0.008-0.0018 in.).

INPUT CLUTCH ASSEMBLY

DISASSEMBLY

(1) Mount input clutch assembly to Input Clutch Pressure Fixture (Tool 8391).

(2) Tap down reverse clutch reaction plate to release pressure from snap ring (Fig. 225).

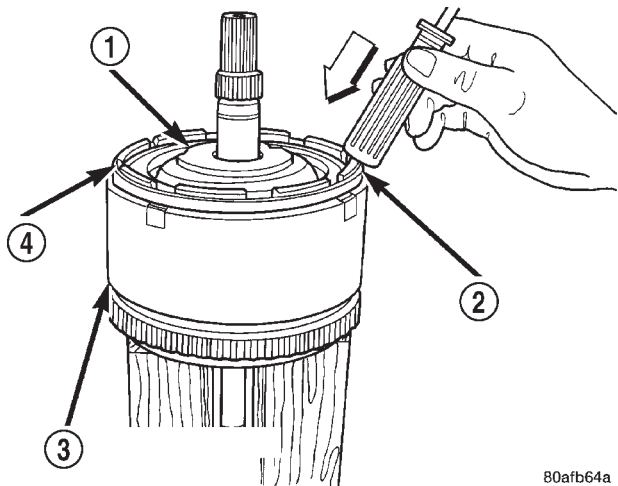

80afb64a

Fig. 225 Tapping Reaction Plate

- 1 - #4 THRUST PLATE (SELECT)
- 2 - TAP DOWN REVERSE CLUTCH REACTION PLATE TO REMOVE OR INSTALL SNAP RING
- 3 - INPUT SHAFT CLUTCHES RETAINER ASSEMBLY
- 4 - REVERSE CLUTCH REACTION PLATE

(3) Remove reverse clutch snap ring (Fig. 226).
 (4) Pry up and remove reverse clutch reaction plate (Fig. 227) (Fig. 228).

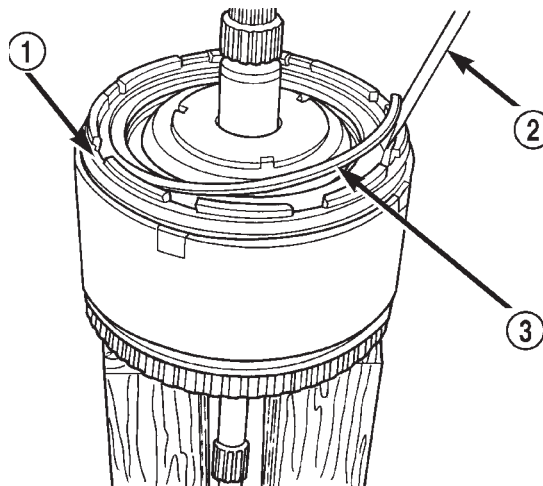

80afb64b

Fig. 226 Reverse Clutch Snap Ring

- 1 - REACTION PLATE
- 2 - SCREWDRIVER
- 3 - REVERSE CLUTCH SNAP RING (SELECT)

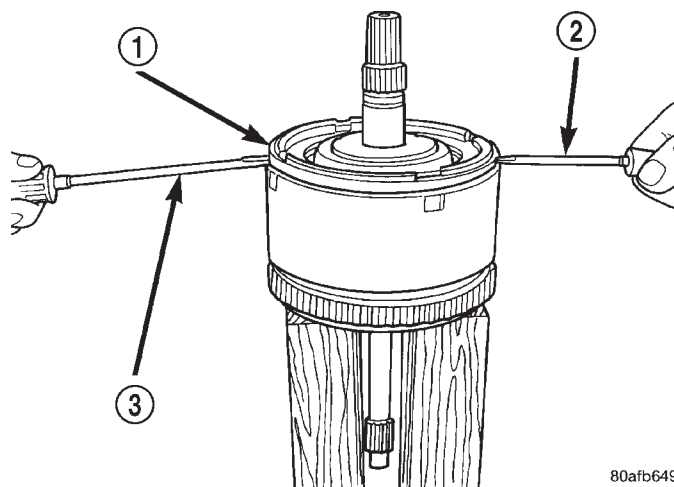

80afb649

Fig. 227 Pry Reverse Clutch Reaction Plate

- 1 - REVERSE CLUTCH REACTION PLATE
- 2 - SCREWDRIVER
- 3 - SCREWDRIVER

(5) Remove the reverse clutch pack (two fibers/one steel) (Fig. 229).

NOTE: Tag reverse clutch pack for reassembly identification.

DISASSEMBLY AND ASSEMBLY (Continued)

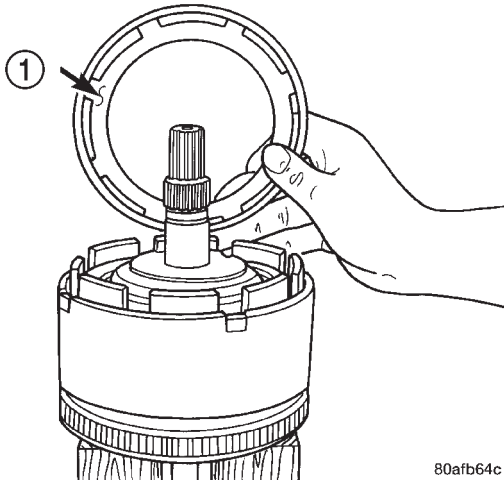

80afb64c

Fig. 228 Reverse Clutch Reaction Plate

- 1 - REVERSE CLUTCH REACTION PLATE (INSTALL FLAT SIDE DOWN)

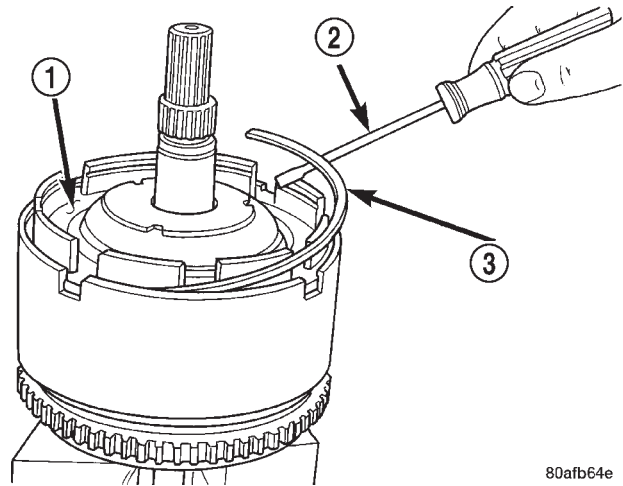

80afb64e

Fig. 230 OD/Reverse Reaction Plate Snap Ring

- 1 - OD/REVERSE PRESSURE PLATE
2 - SCREWDRIVER
3 - OD/REVERSE PRESSURE PLATE SNAP RING

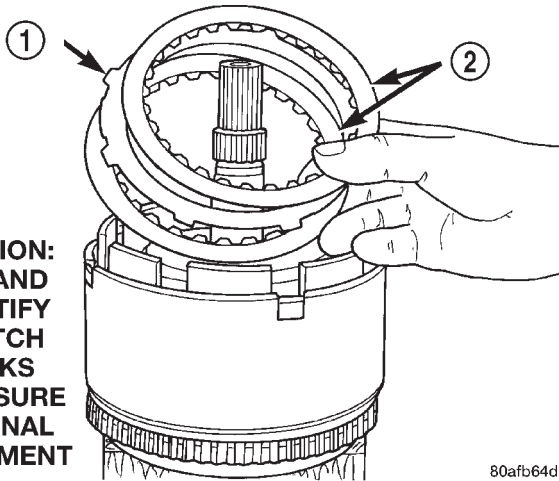

80afb64d

**CAUTION:
TAG AND
IDENTIFY
CLUTCH
PACKS
TO ASSURE
ORIGINAL
PLACEMENT**

Fig. 229 Reverse Clutch Pack

- 1 - REVERSE CLUTCH PLATE
2 - REVERSE CLUTCH DISC

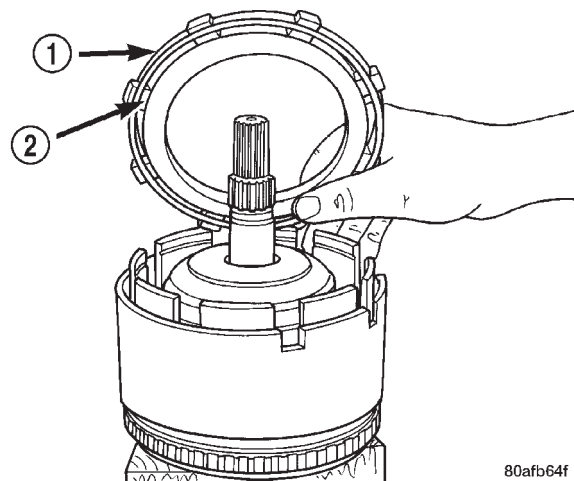

80afb64f

Fig. 231 OD/Reverse Reaction Plate

- 1 - OD/REVERSE PRESSURE PLATE (STEP SIDE DOWN)
2 - (STEP SIDE DOWN)

- (6) Remove the OD/Reverse reaction plate snap ring (Fig. 230).
(7) Remove OD/Reverse reaction plate (Fig. 231).

- (8) Remove OD/Reverse reaction plate wave snap ring (Fig. 232).

DISASSEMBLY AND ASSEMBLY (Continued)

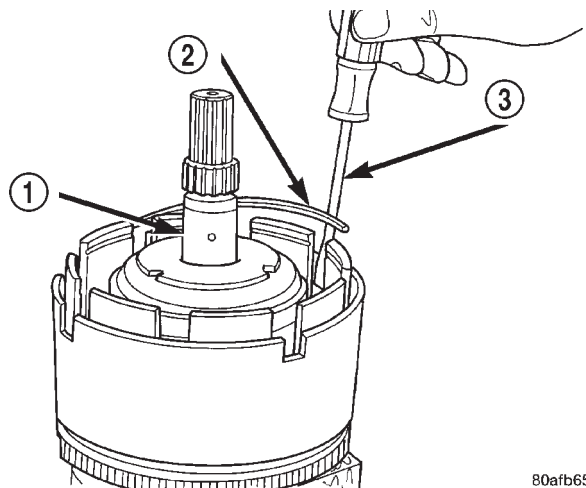

80afb650

Fig. 232 Waved Snap Ring

- 1 - OVERDRIVE SHAFT ASSEMBLY
- 2 - OD/REVERSE CLUTCH WAVED SNAP RING
- 3 - SCREWDRIVER

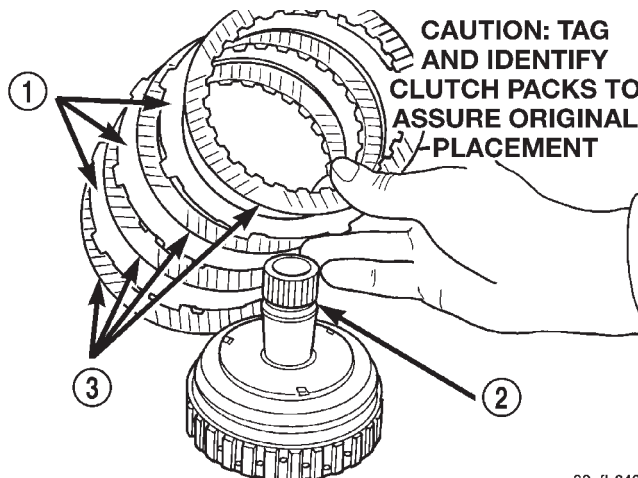

80afb648

Fig. 234 Overdrive Clutch Pack

- 1 - OVERDRIVE CLUTCH PLATE
- 2 - OVERDRIVE SHAFT ASSEMBLY
- 3 - OVERDRIVE CLUTCH DISC

(9) Remove OD shaft/hub and OD clutch pack (Fig. 233) (Fig. 234).

NOTE: Tag overdrive clutch pack for reassembly identification.

(10) Remove and inspect #3 & #4 thrust washers (Fig. 235).

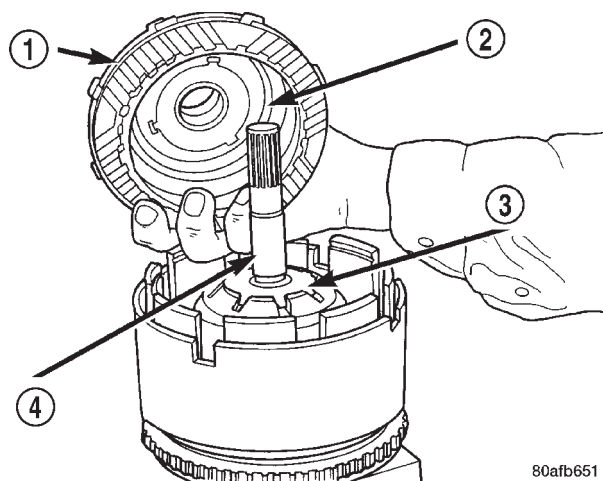

80afb651

Fig. 233 Remove OD Clutch Pack

- 1 - OVERDRIVE SHAFT ASSEMBLY AND OD CLUTCH PACK
- 2 - #3 THRUST PLATE
- 3 - #3 THRUST WASHER
- 4 - UNDERDRIVE SHAFT ASSEMBLY

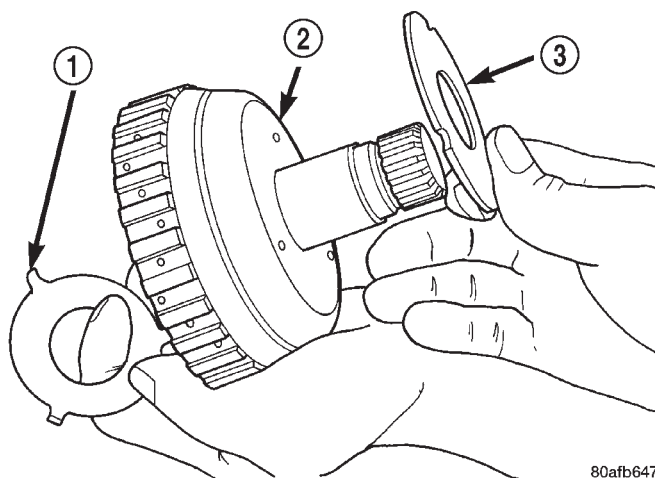

80afb647

Fig. 235 #3&4 Thrust Washers

- 1 - #3 THRUST PLATE (3 TABS)
- 2 - OD SHAFT ASSEMBLY
- 3 - #4 THRUST PLATE (3 SLOTS)

(11) Remove the underdrive shaft assembly (Fig. 236).

(12) Remove the #2 needle bearing (Fig. 237).

DISASSEMBLY AND ASSEMBLY (Continued)

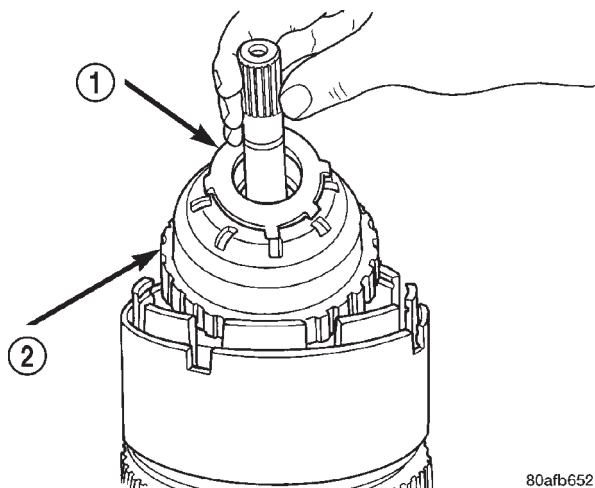

80afb652

Fig. 236 Underdrive Shaft Assembly

- 1 - #3 THRUST WASHER (5 TABS)
- 2 - UNDERDRIVE SHAFT ASSEMBLY

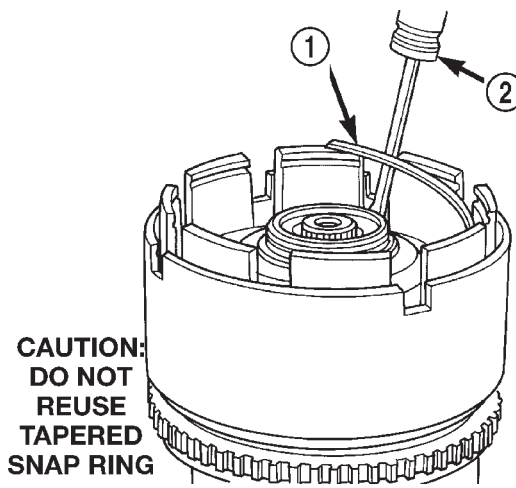

80afb654

Fig. 238 OD/UD Reaction Plate Tapered Snap Ring

- 1 - OVERDRIVE/UNDERDRIVE CLUTCHES REACTION PLATE TAPERED SNAP RING
- 2 - SCREWDRIVER (DO NOT SCRATCH REACTION PLATE)

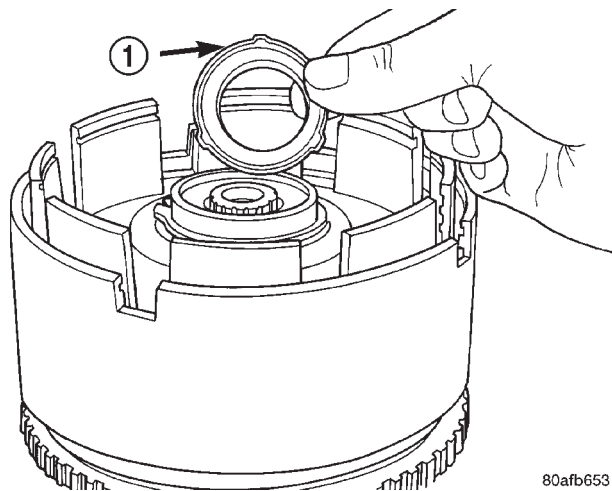

80afb653

Fig. 237 No. 2 Needle Bearing

- 1 - #2 NEEDLE BEARING (NOTE 3 TABS)

NOTE: The OD/UD Reaction Plate, Snap Rings, and Input Clutches Retainer is not interchangeable with previous year 41TE components. The snap rings are thicker and the position of the ring lands have changed.

(13) Remove the OD/UD reaction plate tapered snap ring (Fig. 238).

NOTE: The OD/UD clutch reaction plate has a step on both sides. Install the OD/UD clutches reaction plate tapered step side up.

(14) Remove the OD/UD reaction plate (Fig. 239).

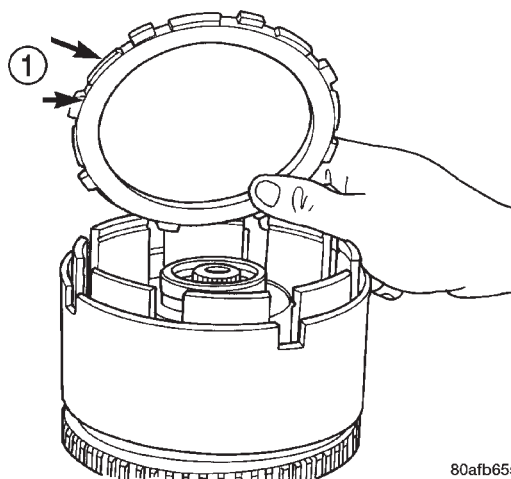

80afb655

Fig. 239 OD/UD Reaction Plate

- 1 - OD/UD CLUTCH REACTION PLATE (STEP SIDE DOWN)

(15) Remove the first UD clutch disc (Fig. 240).
 (16) Remove the UD clutch flat snap ring (Fig. 241).

DISASSEMBLY AND ASSEMBLY (Continued)

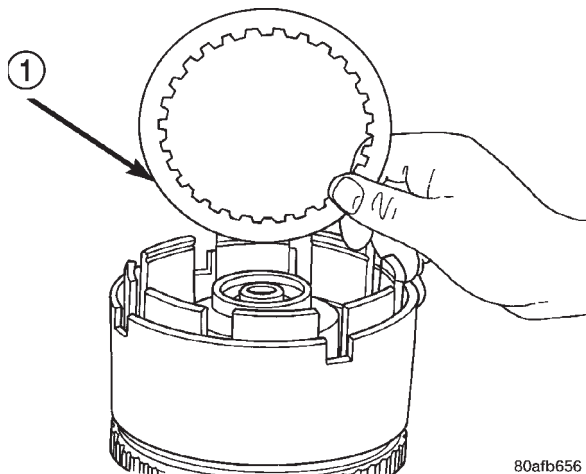

80afb656

Fig. 240 Remove One UD Clutch Disc

1 - ONE UNDERDRIVE CLUTCH DISC

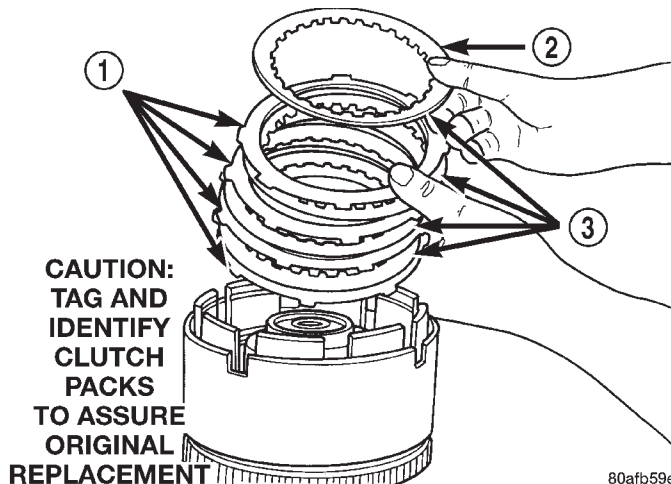

80afb59e

Fig. 242 Underdrive Clutch Pack

1 - CLUTCH PLATE
2 - ONE UD CLUTCH DISC
3 - CLUTCH DISC

**CAUTION:
TAG AND
IDENTIFY
CLUTCH
PACKS
TO ASSURE
ORIGINAL
REPLACEMENT**

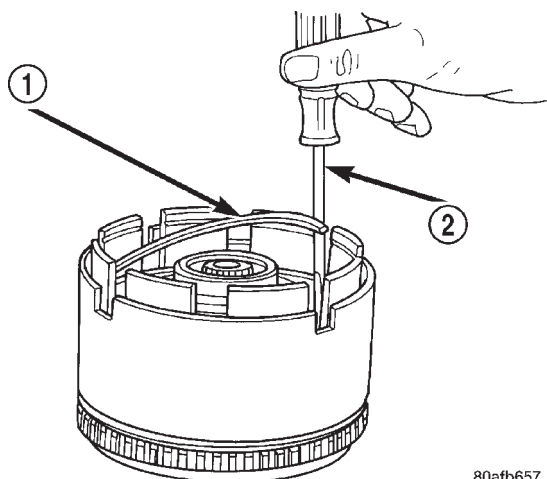

80afb657

Fig. 241 UD Clutch Flat Snap Ring

1 - UNDERDRIVE CLUTCH REACTION PLATE FLAT SNAP RING
2 - SCREWDRIVER

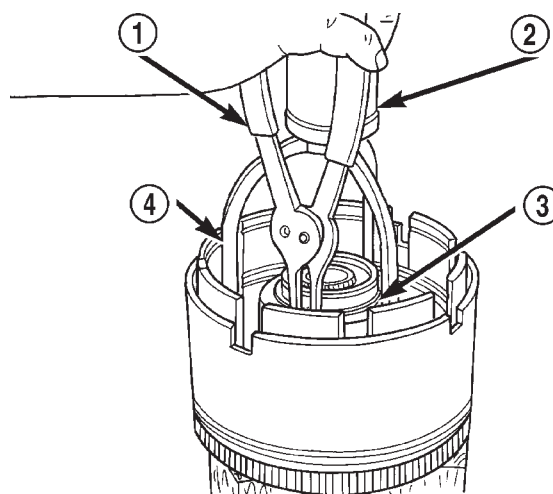

80afb5a3

Fig. 243 UD Spring Retainer Snap Ring

1 - SNAP RING PLIERS
2 - ARBOR PRESS RAM
3 - SNAP RING
4 - SPECIAL TOOL 5059A

NOTE: Tag underdrive clutch pack for reassembly identification.

(17) Remove the UD clutch pack (Fig. 242).

CAUTION: Compress return spring just enough to remove or install snap ring.

(18) Using Tool 5059A and an arbor press, compress UD clutch piston enough to remove snap ring (Fig. 243) (Fig. 244).

(19) Remove spring retainer (Fig. 244).
(20) Remove UD clutch piston (Fig. 245).
(21) Remove input hub tapered snap ring (Fig. 246).
(22) Tap on input hub with soft faced hammer and separate input hub from OD/Reverse piston and clutch retainer (Fig. 247) (Fig. 248).

DISASSEMBLY AND ASSEMBLY (Continued)

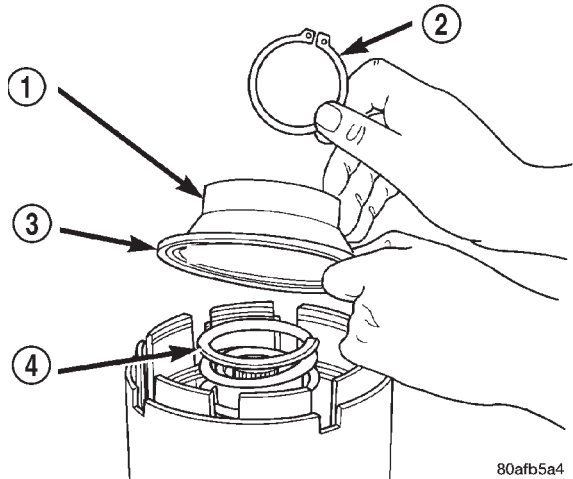

80afb5a4

Fig. 244 UD Return Spring and Retainer

- 1 - UNDERDRIVE SPRING RETAINER
- 2 - SNAP RING
- 3 - SEAL
- 4 - PISTON RETURN SPRING

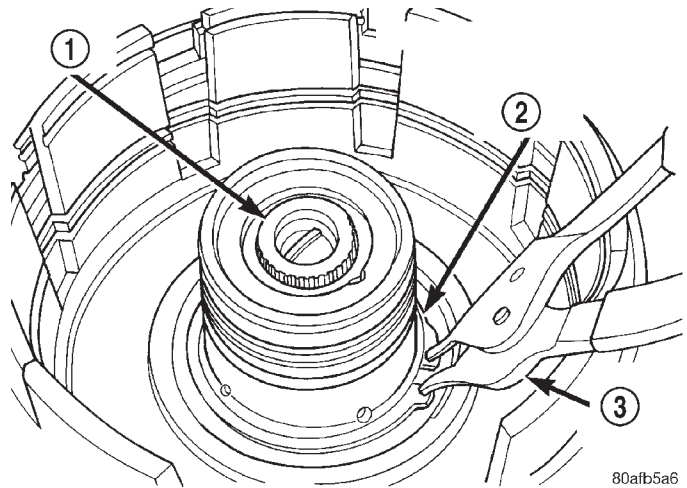

80afb5a6

Fig. 246 Input Hub Tapered Snap Ring

- 1 - INPUT SHAFT
- 2 - INPUT HUB SNAP RING (TAPERED SIDE UP WITH TABS IN CAVITY)
- 3 - SNAP RING PLIERS

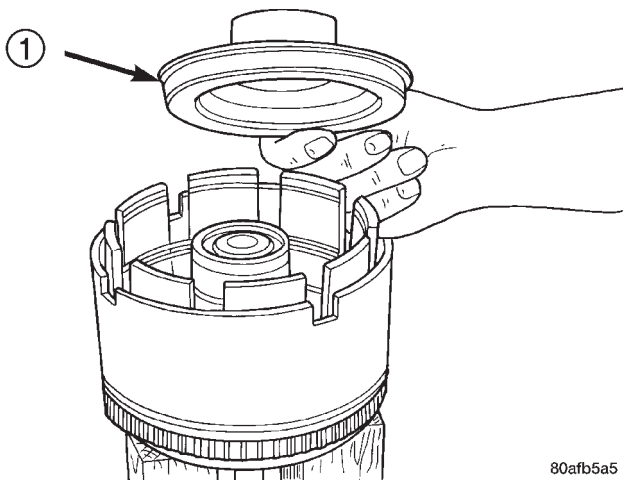

80afb5a5

Fig. 245 Underdrive Clutch Piston

- 1 - PISTON

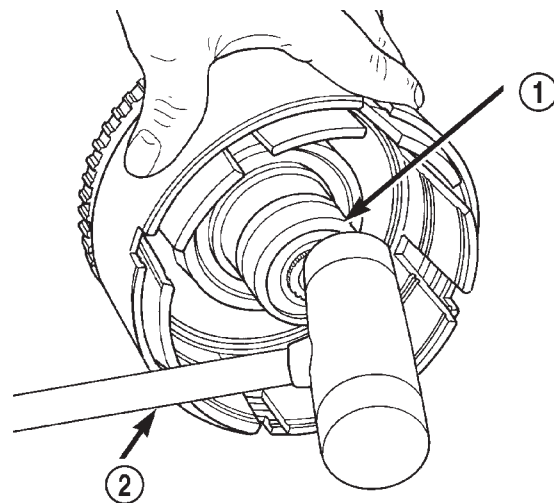

80afb5a7

Fig. 247 Tap on Input Hub

- 1 - INPUT SHAFT AND HUB ASSEMBLY
- 2 - PLASTIC HAMMER

(23) Separate clutch retainer from OD/Reverse piston (Fig. 249).

DISASSEMBLY AND ASSEMBLY (Continued)

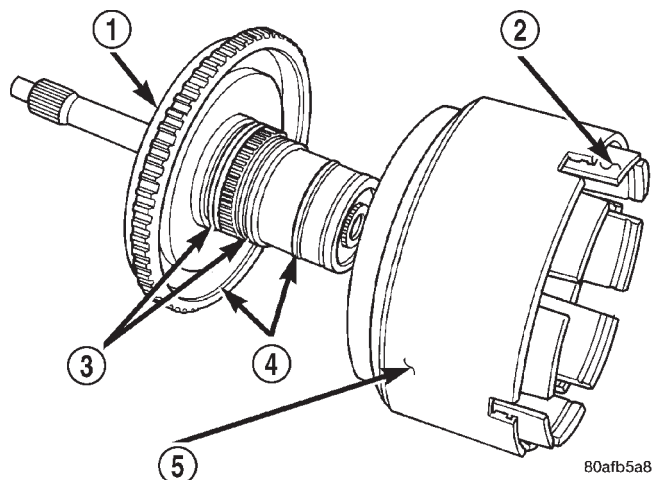

Fig. 248 Input Hub Removed

- 1 - INPUT SHAFT AND HUB ASSEMBLY
- 2 - INPUT CLUTCHES RETAINER
- 3 - O-RING
- 4 - SEAL
- 5 - OVERDRIVE/REVERSE PISTON

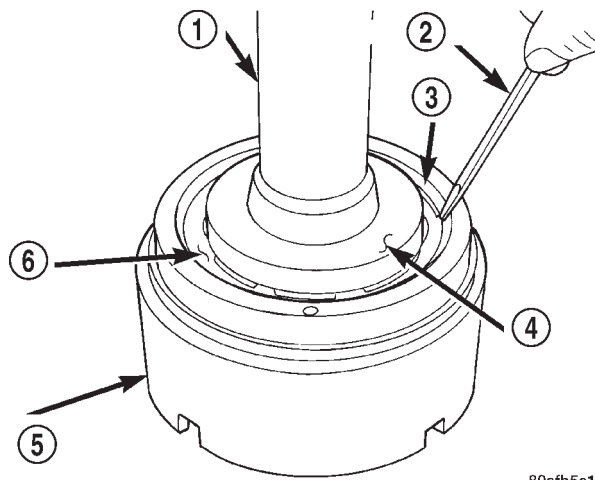

Fig. 250 Remove Snap Ring

- 1 - ARBOR PRESS RAM (COMPRESS RETURN SPRING JUST ENOUGH TO REMOVE OR INSTALL SNAP RING)
- 2 - SCREWDRIVER
- 3 - SNAP RING
- 4 - SPECIAL TOOL 6057
- 5 - OD/REVERSE PISTON
- 6 - RETURN SPRING

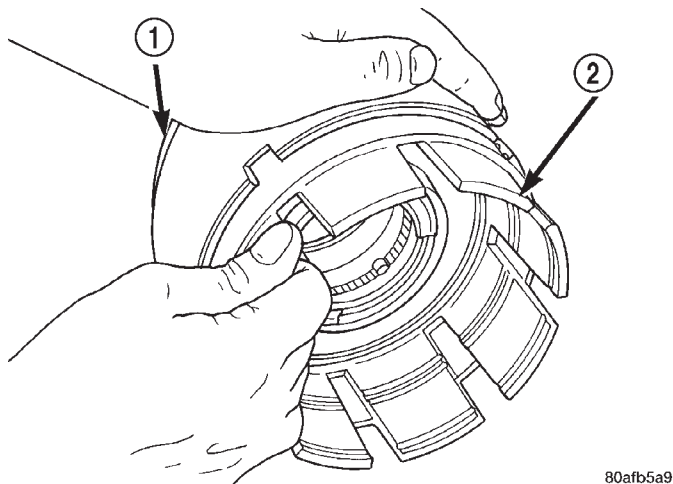

Fig. 249 Pull Retainer from Piston

- 1 - OVERDRIVE/REVERSE PISTON
- 2 - INPUT CLUTCHES RETAINER

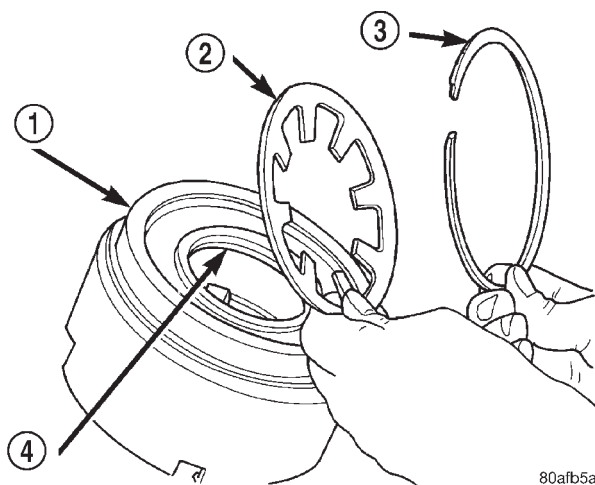

Fig. 251 Snap Ring and Return Spring

- 1 - OD/REVERSE PISTON
- 2 - RETURN SPRING
- 3 - SNAP RING
- 4 - O-RING

(24) Using Tool 6057 and an arbor press, compress return OD/Reverse piston return spring just enough to remove snap ring (Fig. 250) (Fig. 251).

DISASSEMBLY AND ASSEMBLY (Continued)

(25) Remove input shaft to input clutch hub snap ring (Fig. 252).

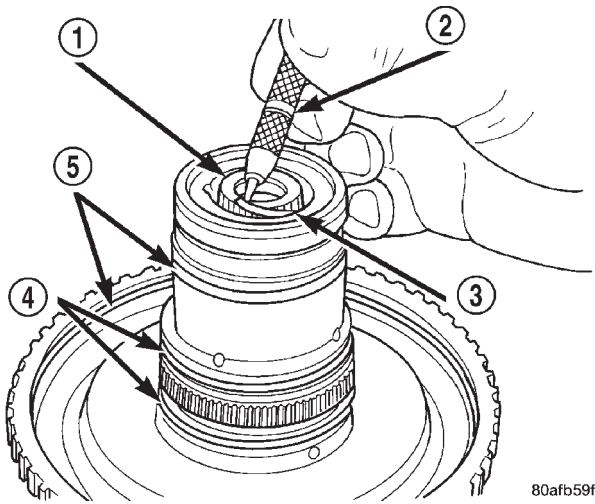

80afb59f

Fig. 252 Remove Input Shaft Snap Ring

- 1 - INPUT SHAFT
- 2 - SHARP-POINTED TOOL
- 3 - SNAP RING
- 4 - O-RINGS
- 5 - SEALS

ASSEMBLY

Use petrolatum on all seals to ease assembly of components.

(1) Using an arbor press, install input shaft to input shaft hub (Fig. 254).

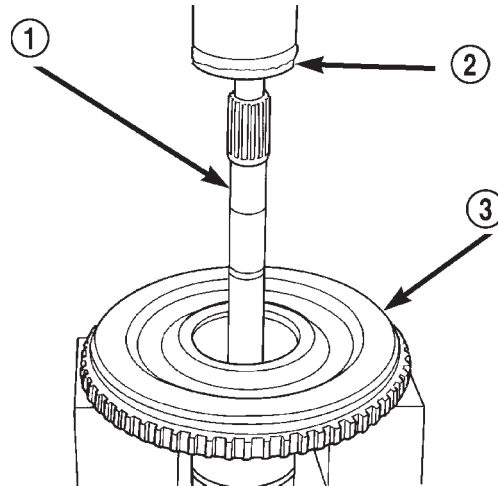

80afb5aa

Fig. 254 Install Input Shaft

- 1 - INPUT SHAFT
- 2 - ARBOR PRESS RAM
- 3 - INPUT SHAFT HUB ASSEMBLY

(26) Using a suitably sized socket and an arbor press, remove input shaft from input shaft hub (Fig. 253).

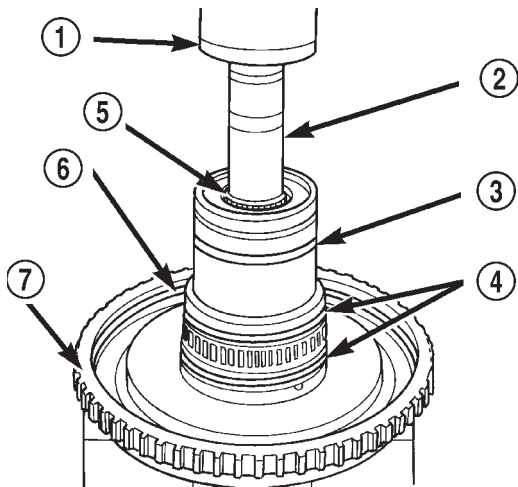

80afb5a0

Fig. 253 Remove Input Shaft

- 1 - ARBOR PRESS RAM
- 2 - SOCKET
- 3 - SEAL
- 4 - O-RINGS
- 5 - INPUT SHAFT
- 6 - SEAL
- 7 - INPUT SHAFT HUB ASSEMBLY

(2) Install input shaft snap ring (Fig. 255).

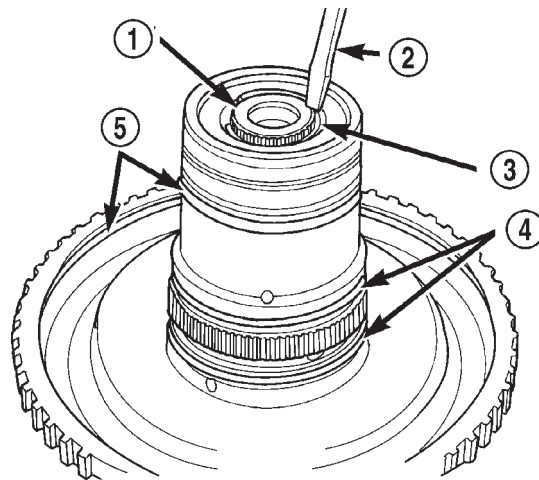

80afb5ab

Fig. 255 Install Input Shaft Snap Ring

- 1 - INPUT SHAFT
- 2 - SCREWDRIVER (DO NOT SCRATCH BEARING SURFACE)
- 3 - SNAP RING
- 4 - O-RINGS
- 5 - SEALS

(3) Using an arbor press and Tool 6057, Install OD/Reverse piston return spring and snap ring (Fig. 256) (Fig. 257).

DISASSEMBLY AND ASSEMBLY (Continued)

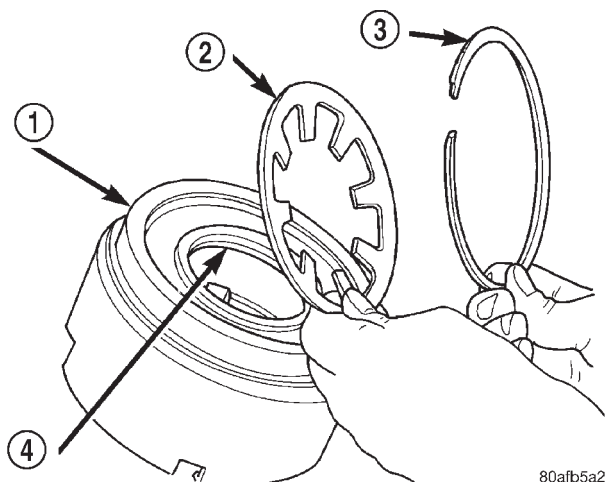

Fig. 256 Return Spring and Snap Ring

- 1 - OD/REVERSE PISTON
- 2 - RETURN SPRING
- 3 - SNAP RING
- 4 - O-RING

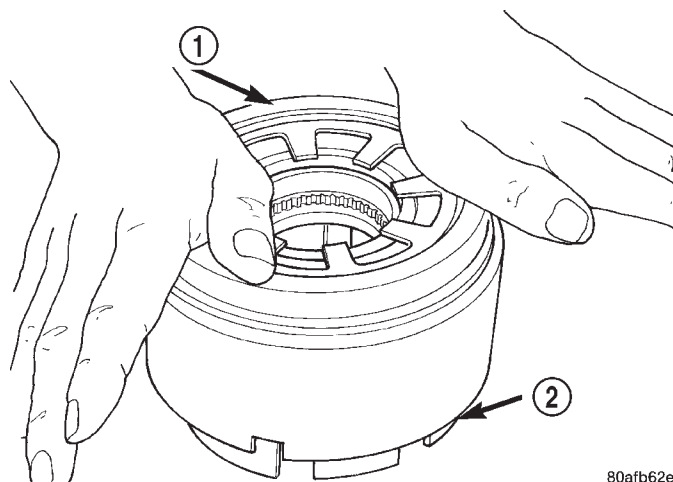

Fig. 258 Install OD/Reverse Piston

- 1 - PUSH DOWN TO INSTALL OVERDRIVE/REVERSE PISTON
- 2 - INPUT CLUTCHES RETAINER

(5) Install the input hub/shaft assy. to the OD/Reverse piston/clutch retainer assy. (Fig. 259).

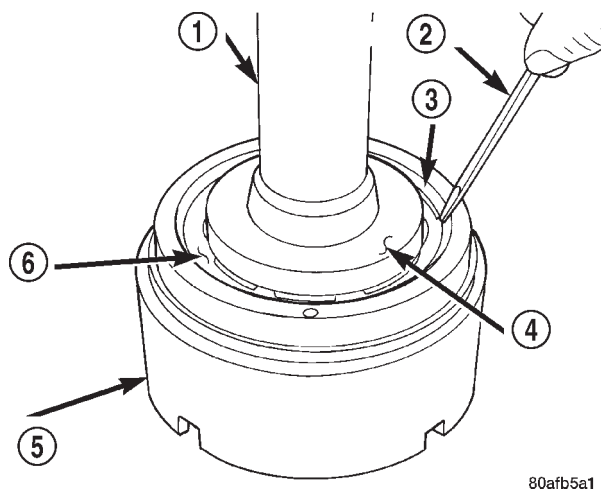

Fig. 257 Install Snap Ring

- 1 - ARBOR PRESS RAM (COMPRESS RETURN SPRING JUST ENOUGH TO REMOVE OR INSTALL SNAP RING)
- 2 - SCREWDRIVER
- 3 - SNAP RING
- 4 - SPECIAL TOOL 6057
- 5 - OD/REVERSE PISTON
- 6 - RETURN SPRING

(4) Install the OD/Reverse piston assembly to the input clutch retainer as shown in (Fig. 258).

NOTE: The OD/UD Reaction Plate, Snap Rings, and Input Clutches Retainer is not interchangeable with previous year 41TE components. The snap rings are thicker and the position of the ring lands have changed.

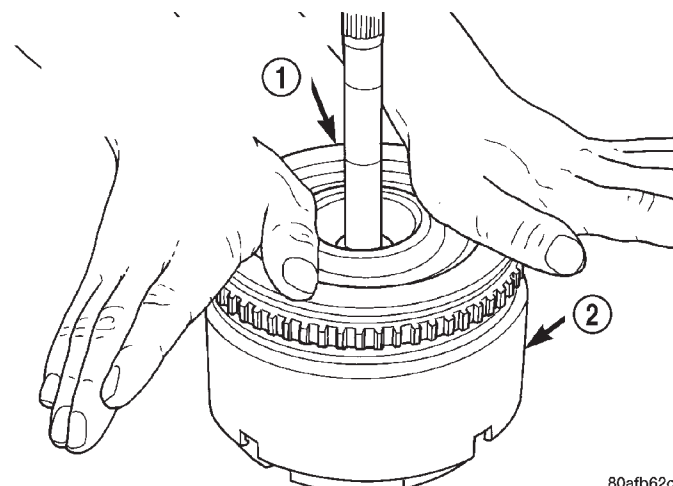

Fig. 259 Install Input Shaft Hub Assembly

- 1 - PUSH DOWN TO INSTALL INPUT SHAFT HUB ASSEMBLY (ROTATE TO ALIGN SPLINES)
- 2 - OD/REV. PISTON

- (6) Install input hub tapered snap ring (Fig. 260).
- (7) Install UD clutch piston (Fig. 261).
- (8) Install UD piston return spring and Tool 5067 as shown in (Fig. 262).
- (9) Using Tool 5059A and an arbor press, Install the UD spring retainer and snap ring. (Fig. 263) (Fig. 264) Compress just enough to install snap ring.

CAUTION: Compress return spring just enough to install snap ring.

DISASSEMBLY AND ASSEMBLY (Continued)

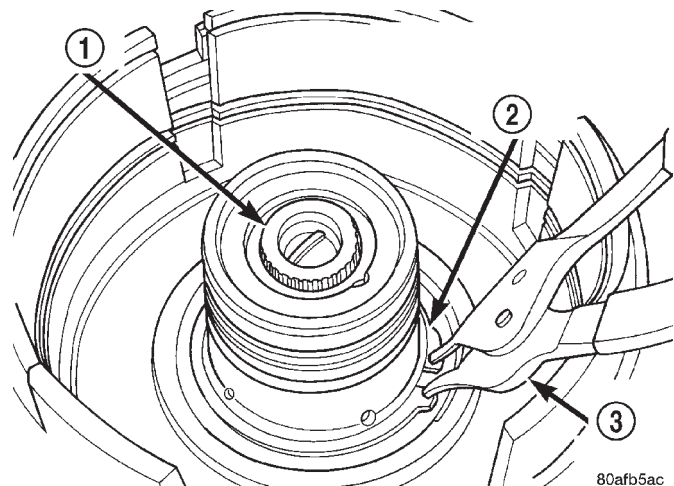

Fig. 260 Install Input Hub Tapered Snap Ring

- 1 - INPUT SHAFT
- 2 - INPUT HUB SNAP RING (TAPERED SIDE UP WITH TABS IN CAVITY)
- 3 - SNAP RING PLIERS

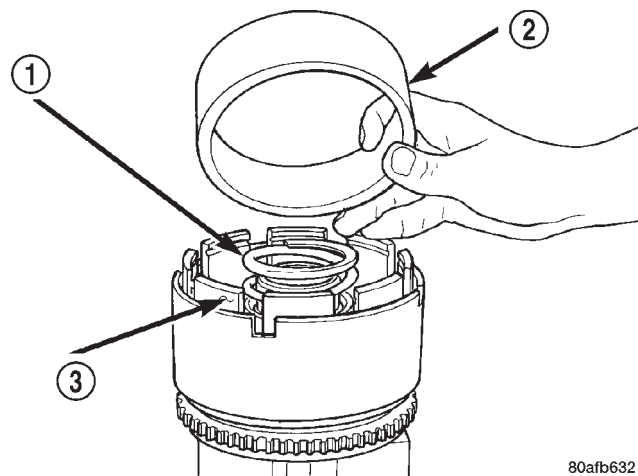

Fig. 262 Seal Compressor Special Tool 5067

- 1 - PISTON RETURN SPRING
- 2 - SPECIAL TOOL 5067
- 3 - INPUT SHAFT CLUTCHES RETAINER ASSEMBLY

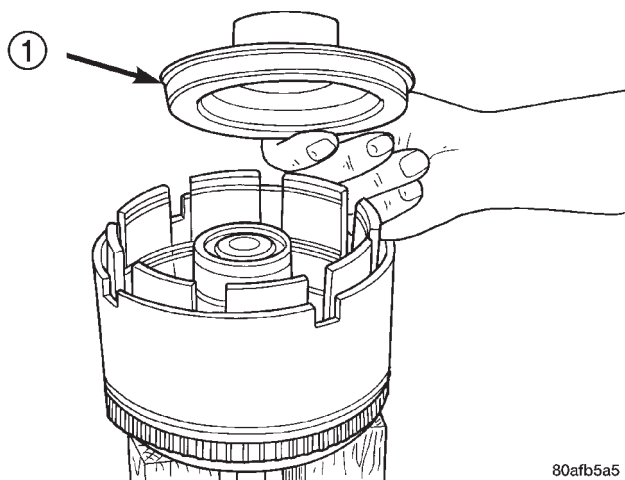

Fig. 261 Underdrive Clutch Piston

- 1 - PISTON

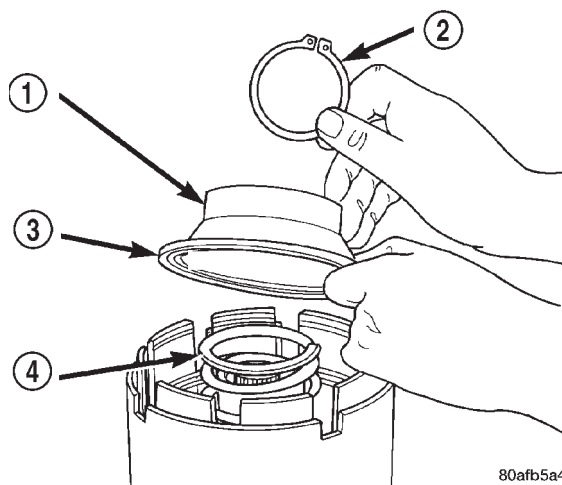

Fig. 263 UD Return Spring and Retainer

- 1 - UNDERDRIVE SPRING RETAINER
- 2 - SNAP RING
- 3 - SEAL
- 4 - PISTON RETURN SPRING

(10) Install the UD clutch pack (four fibers/four steels) (Fig. 265).

(11) Install the UD clutch flat snap ring (Fig. 266).

(12) Install the last UD clutch disc (Fig. 267).

DISASSEMBLY AND ASSEMBLY (Continued)

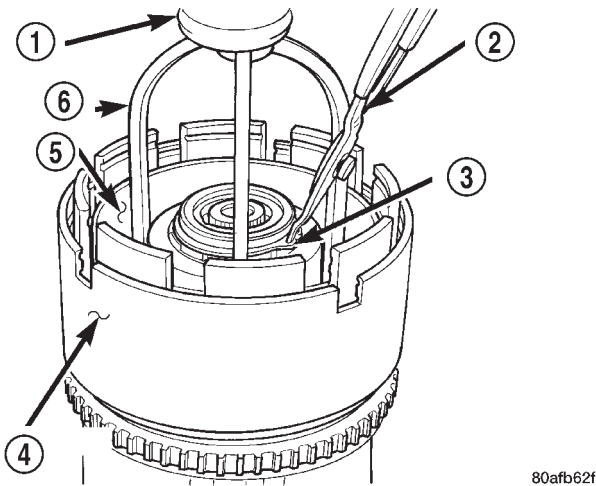

80afb62f

Fig. 264 Install UD Spring Retainer and Snap Ring

- 1 - ARBOR PRESS RAM
- 2 - SNAP RING PLIERS
- 3 - SNAP RING
- 4 - OD/REVERSE PISTON
- 5 - TOOL 5067
- 6 - TOOL 5059A

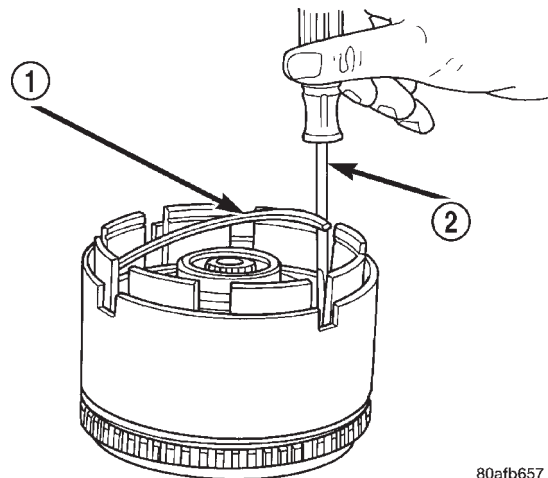

80afb657

Fig. 266 UD Clutch Flat Snap Ring

- 1 - UNDERDRIVE CLUTCH REACTION PLATE FLAT SNAP RING
- 2 - SCREWDRIVER

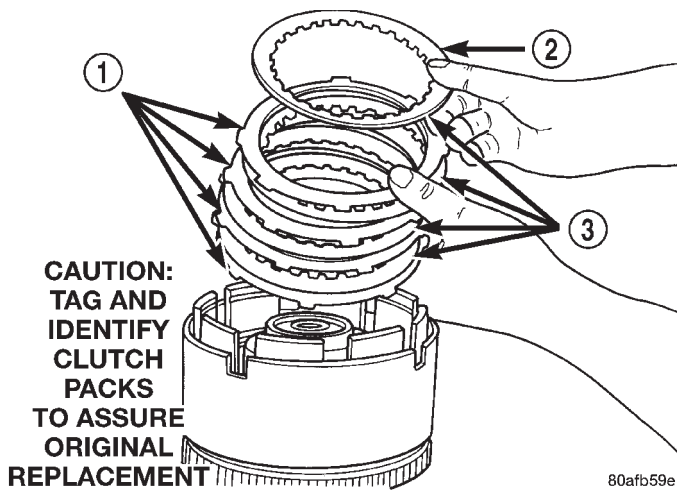

80afb59e

**CAUTION:
TAG AND
IDENTIFY
CLUTCH
PACKS
TO ASSURE
ORIGINAL
REPLACEMENT**

Fig. 265 Underdrive Clutch Pack

- 1 - CLUTCH PLATE
- 2 - ONE UD CLUTCH DISC
- 3 - CLUTCH DISC

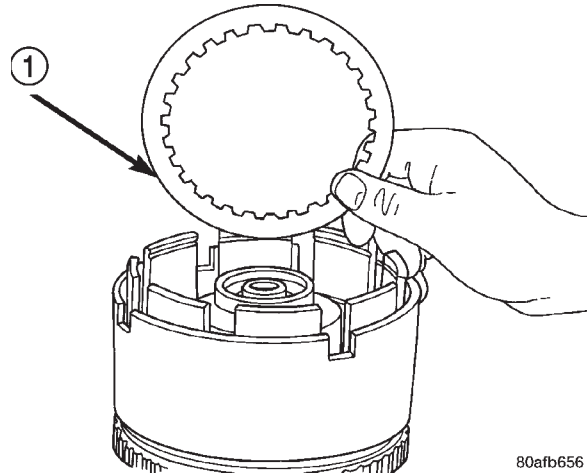

80afb656

Fig. 267 Install Last UD Clutch Disc

- 1 - ONE UNDERDRIVE CLUTCH DISC

(13) Install the OD/UD clutch reaction plate and snap ring (Fig. 268) (Fig. 269). The OD/UD clutches reaction plate has a step on both sides. Install the OD/UD clutches reaction plate tapered step side up.

DISASSEMBLY AND ASSEMBLY (Continued)

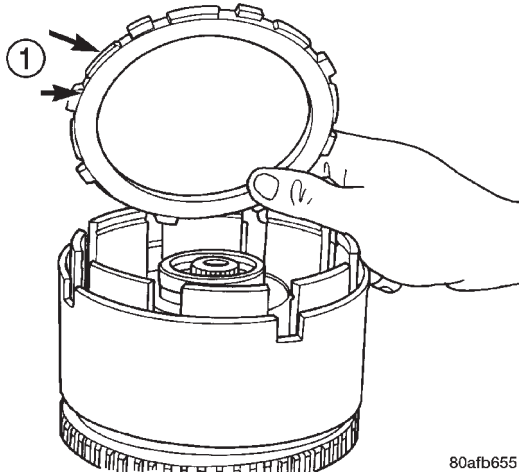

80afb655

Fig. 268 OD/UD Reaction Plate

- 1 - OD/UD CLUTCH REACTION PLATE (STEP SIDE DOWN)

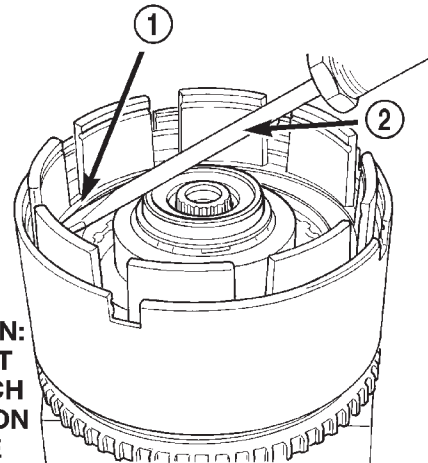

80afb630

USE CAUTION: DO NOT SCRATCH REACTION PLATE

Fig. 270 Seating Tapered Snap Ring

- 1 - OVERDRIVE/UNDERDRIVE CLUTCHES REACTION PLATE TAPERED SNAP RING
2 - SCREWDRIVER

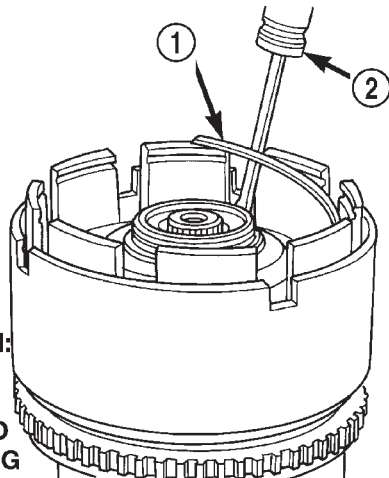

80afb654

CAUTION: DO NOT REUSE TAPERED SNAP RING

Fig. 269 Tapered Snap Ring

- 1 - OVERDRIVE/UNDERDRIVE CLUTCHES REACTION PLATE TAPERED SNAP RING
2 - SCREWDRIVER (DO NOT SCRATCH REACTION PLATE)

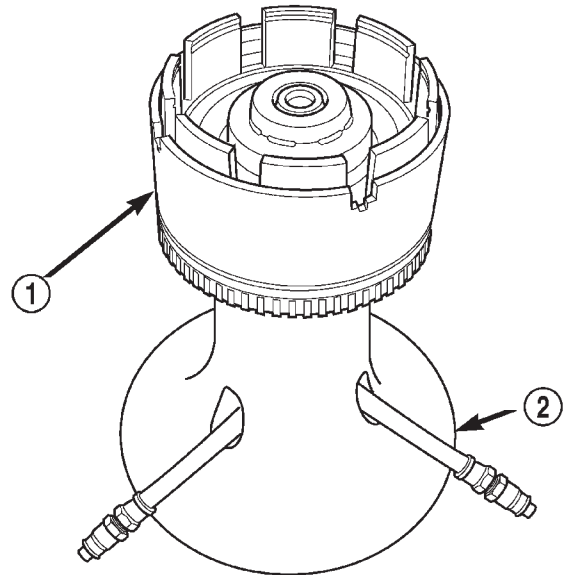

80c07260

Fig. 271 Input Clutch Assembly on Pressure Fixture Tool 8391

- 1 - INPUT CLUTCH ASSEMBLY
2 - INPUT CLUTCH PRESSURE FIXTURE 8391

NOTE: Snap ring ends must be located within one finger of the input clutch hub. Be sure that snap ring is fully seated, by pushing with screwdriver, into snap ring groove all the way around.

(14) Seat tapered snap ring to ensure proper installation (Fig. 270).

(15) Install input clutch assembly to the Input Clutch Pressure Fixture-Tool 8391 (Fig. 271).

(16) Set up dial indicator on the UD clutch pack as shown in (Fig. 272).

(17) Using moderate pressure, press down and hold (near indicator) the UD clutch pack with screwdriver or suitable tool and zero dial indicator (Fig. 273). When releasing pressure on clutch pack, indicator reading should advance 0.005-0.010.

CAUTION: Do not apply more than 30 psi (206 kPa) to the underdrive clutch pack.

(18) Apply 30 psi (206 kPa) to the underdrive hose on Tool 8391 and measure UD clutch clearance. Measure and record UD clutch pack measurement in four (4) places, 90° apart.

DISASSEMBLY AND ASSEMBLY (Continued)

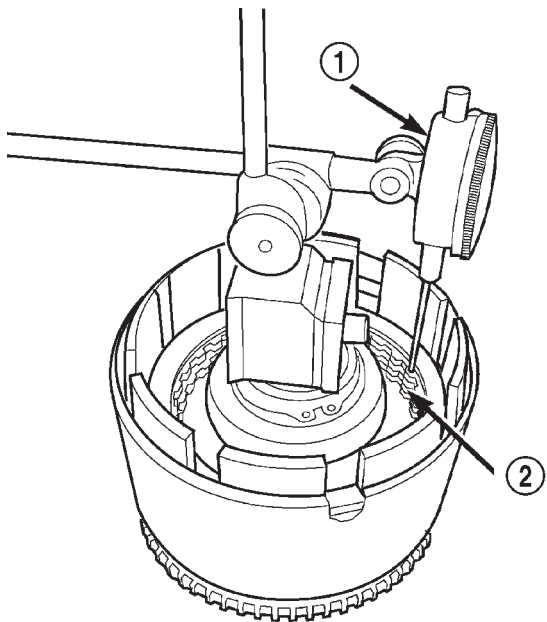

80c07261

Fig. 272 Set Up Dial Indicator to Measure UD Clutch Clearance

- 1 - DIAL INDICATOR
- 2 - UNDERDRIVE CLUTCH

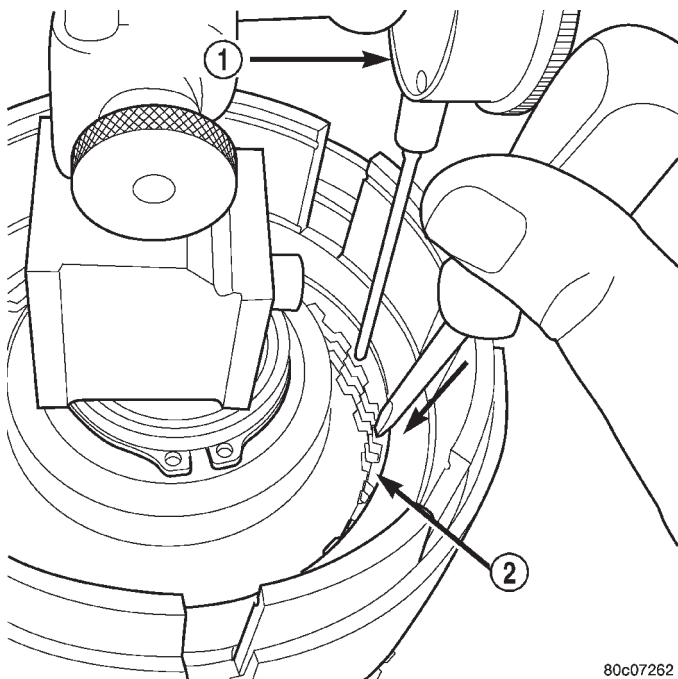

80c07262

Fig. 273 Press Down on UD Clutch Pack and Zero Dial Indicator

- 1 - DIAL INDICATOR
- 2 - UNDERDRIVE CLUTCH

(19) Take average of four measurements and compare with UD clutch pack clearance specification. **Underdrive clutch pack clearance must be 0.94-1.50 mm (0.037-0.059 in.).**

(20) If necessary, select the proper reaction plate to achieve specifications:

UNDERDRIVE REACTION PLATE THICKNESS	
4659939AB	5.837-5.937 mm (0.230-0.234 in.)
4659940AB	6.147-6.248 mm (0.242-0.246 in.)
4659941AB	6.457-6.557 mm (0.254-0.258 in.)

(21) Install the OD clutch pack (four fibers/four steels) (Fig. 274).

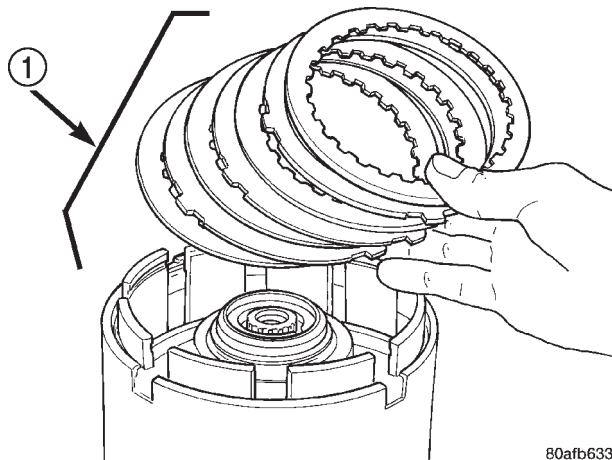

80afb633

Fig. 274 Install OD Clutch Pack

- 1 - OVERDRIVE CLUTCH PACK

(22) Install OD reaction plate waved snap ring (Fig. 275).

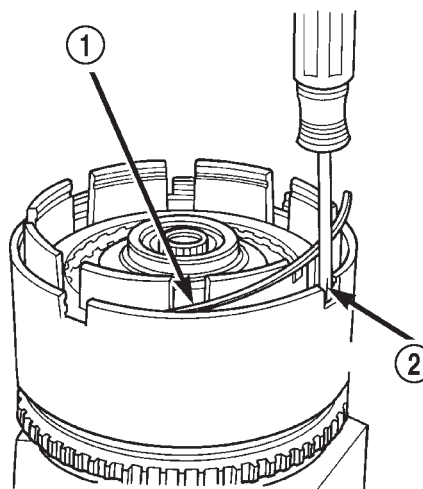

80aff57b

Fig. 275 Install Waved Snap Ring

- 1 - OVERDRIVE REACTION PLATE WAVED SNAP RING
- 2 - SCREWDRIVER

(23) Install the OD/Reverse reaction plate with large step down (towards OD clutch pack) (Fig. 276).

(24) Install OD reaction plate flat snap ring (Fig. 277).

DISASSEMBLY AND ASSEMBLY (Continued)

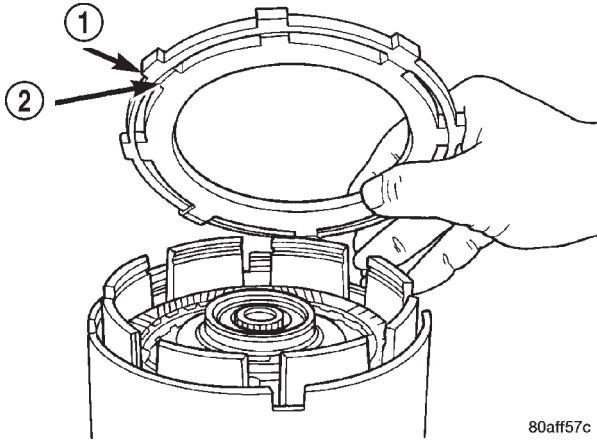

80aff57c

Fig. 276 OD/Reverse Reaction Plate

- 1 - OVERDRIVE/REVERSE PRESSURE PLATE
- 2 - (STEP SIDE DOWN)

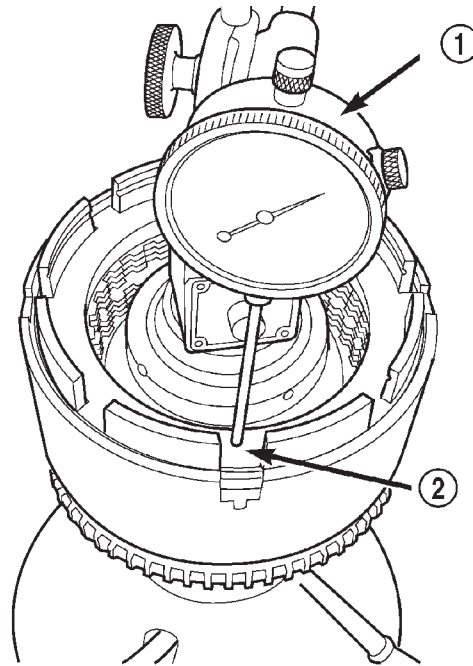

80c07263

Fig. 278 Measure OD Clutch Pack Clearance

- 1 - DIAL INDICATOR
- 2 - OD/REVERSE REACTION PLATE

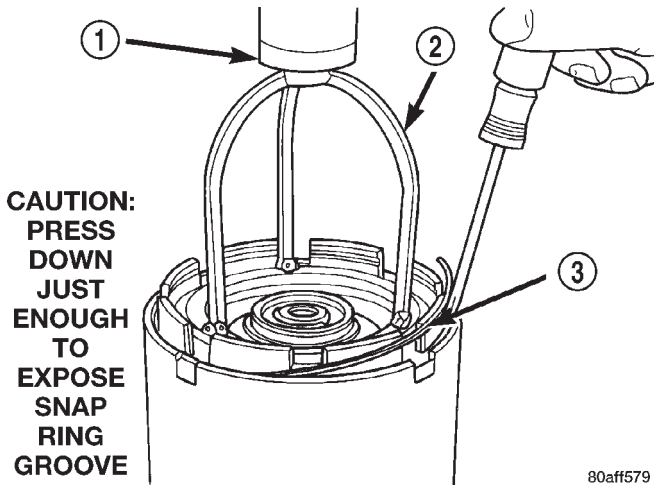

**CAUTION:
PRESS
DOWN
JUST
ENOUGH
TO
EXPOSE
SNAP
RING
GROOVE**

80aff579

Fig. 277 Install Flat Snap Ring

- 1 - ARBOR PRESS RAM
- 2 - TOOL 5059A
- 3 - FLAT SNAP RING

(25) Measure OD clutch pack clearance. Set up dial indicator on top of the OD/Reverse reaction plate as shown in (Fig. 278).

(26) Zero dial indicator and apply 30 psi (206 kPa) air pressure to the overdrive clutch hose on Tool 8391. Measure and record OD clutch pack measurement in four (4) places, 90° apart.

(27) Take average of four measurements and compare with OD clutch pack clearance specification. **The overdrive (OD) clutch pack clearance is 1.07-3.25 mm (0.042-0.128 in.).**

If not within specifications, the clutch is not assembled properly. There is no adjustment for the OD clutch clearance.

(28) Install reverse clutch pack (two fibers/one steel) (Fig. 279).

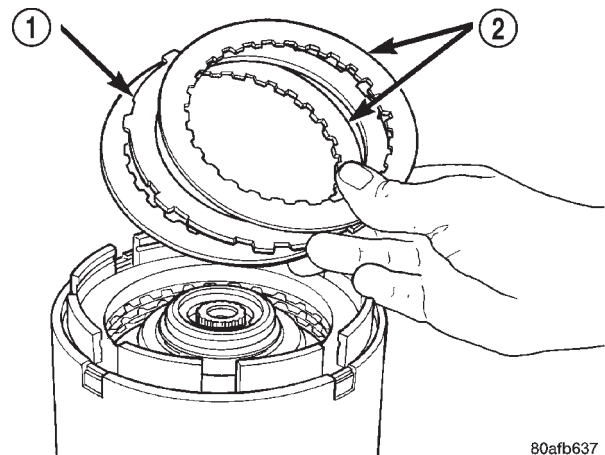

80afb637

Fig. 279 Install Reverse Clutch Pack

- 1 - REVERSE CLUTCH PLATE
- 2 - REVERSE CLUTCH DISCS

DISASSEMBLY AND ASSEMBLY (Continued)

(29) Install reverse clutch reaction plate with the flat side down towards reverse clutch (Fig. 280).

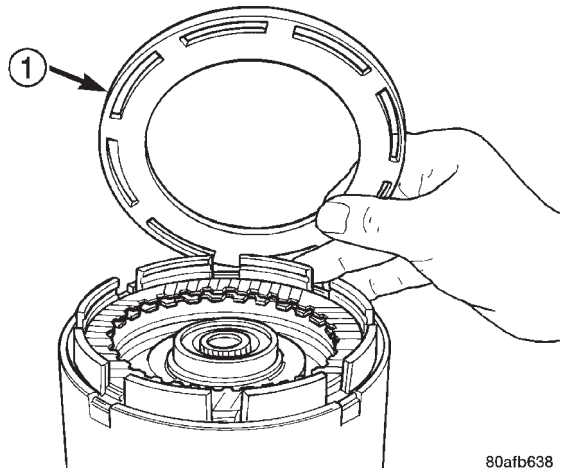

80afb638

Fig. 280 Install Reaction Plate

- 1 - REVERSE CLUTCH REACTION PLATE (FLAT SIDE DOWN)

(30) Tap reaction plate down to allow installation of the reverse clutch snap ring. Install reverse clutch snap ring (Fig. 281).

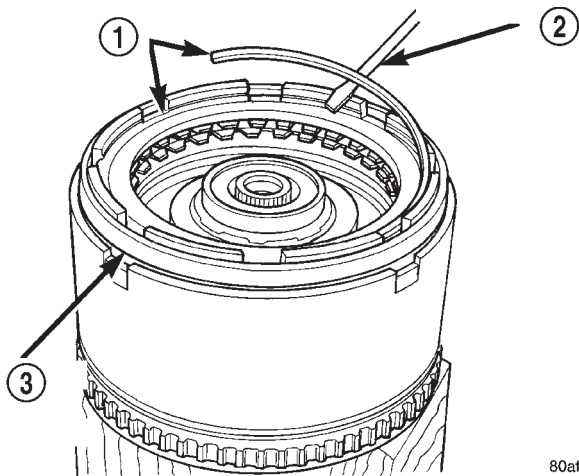

80afb639

Fig. 281 Install Reverse Clutch Snap Ring

- 1 - REVERSE CLUTCH SNAP RING (SELECT)
- 2 - SCREWDRIVER
- 3 - REVERSE CLUTCH REACTION PLATE

(31) Pry up reverse reaction plate to seat against snap ring (Fig. 282).

(32) Set up a dial indicator on the reverse clutch pack as shown in (Fig. 283).

(33) Using moderate pressure, press down and hold (near indicator) reverse clutch disc with screwdriver or suitable tool and zero dial indicator (Fig. 284). When releasing pressure, indicator should advance 0.005-0.010. as clutch pack relaxes.

(34) Apply 30 psi (206 kPa) air pressure to the reverse clutch hose on Tool 8391. Measure and record

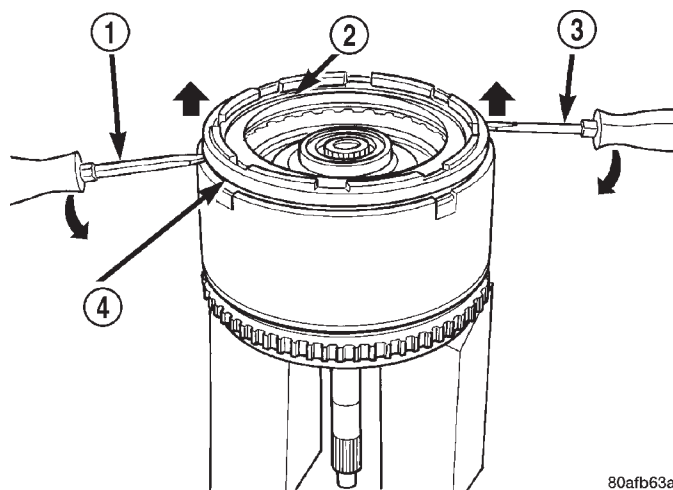

80afb63a

Fig. 282 Pry Up Reaction Plate to Seat Against Snap Ring

- 1 - SCREWDRIVER
- 2 - SNAP RING
- 3 - SCREWDRIVER
- 4 - MUST RAISE REVERSE REACTION PLATE TO RAISE SNAP RING

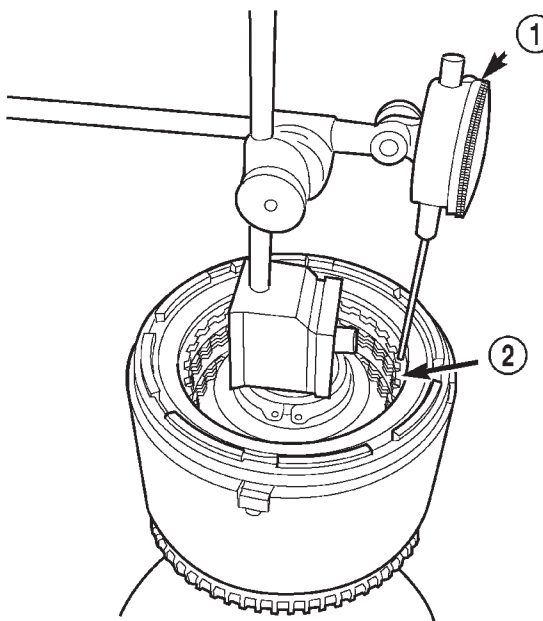

80c07264

Fig. 283 Measure Reverse Clutch Pack Clearance

- 1 - DIAL INDICATOR
- 2 - REVERSE CLUTCH

reverse clutch pack measurement in four (4) places, 90° apart.

(35) Take average of four measurements and compare with reverse clutch pack clearance specification. **The reverse clutch pack clearance is 0.89-1.37 mm (0.035-0.054 in.).** Select the proper reverse clutch snap ring to achieve specifications:

DISASSEMBLY AND ASSEMBLY (Continued)

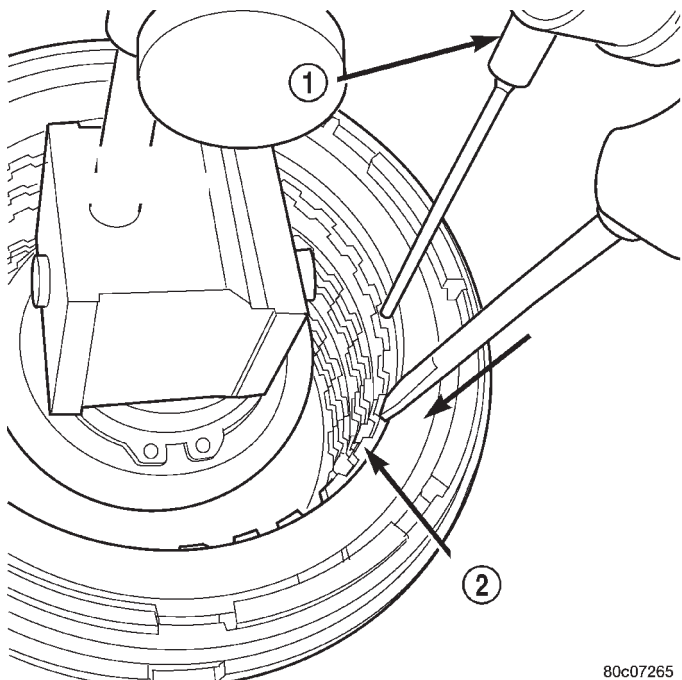

Fig. 284 Press Down on Reverse Clutch and Zero Indicator

- 1 - DIAL INDICATOR
- 2 - REVERSE CLUTCH

REVERSE CLUTCH SNAP RING THICKNESS	
4377195	1.53-1.58 mm (0.060-0.062 in.)
4412871	1.77-1.83 mm (0.070-0.072 in.)
4412872	2.02-2.07 mm (0.080-0.082 in.)
4412873	2.27-2.32 mm (0.090-0.091 in.)

(36) To complete the assembly, reverse clutch and overdrive clutch must be removed.

(37) Install the #2 needle bearing (Fig. 285).

(38) Install the underdrive shaft assembly (Fig. 286).

(39) Install the #3 thrust washer to the underdrive shaft assembly. Be sure five tabs are seated properly (Fig. 287).

(40) Install the #3 thrust plate to the bottom of the overdrive shaft assembly. Retain with petrolatum or transmission assembly gel (Fig. 288).

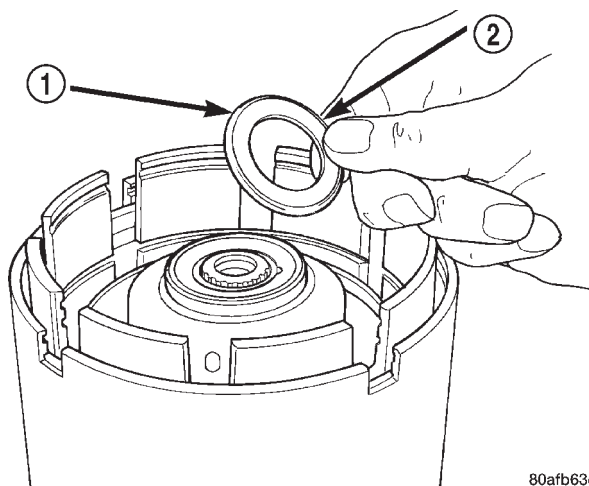

Fig. 285 Install No. 2 Needle Bearing

- 1 - #2 NEEDLE BEARING (NOTE 3 SMALL TABS)
- 2 - TABS UP

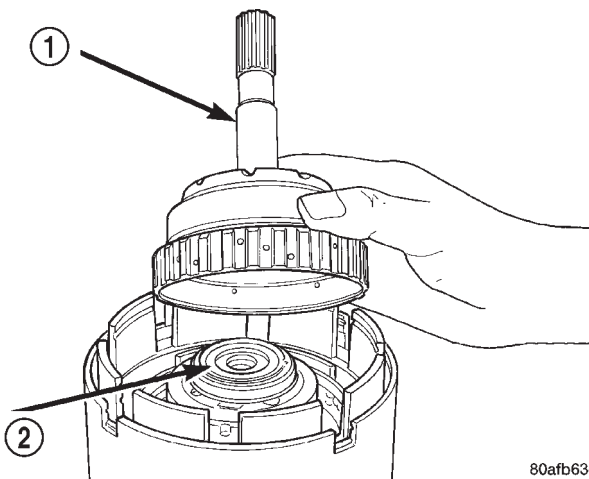

Fig. 286 Install Underdrive Shaft Assembly

- 1 - UNDERDRIVE SHAFT ASSEMBLY
- 2 - #2 NEEDLE BEARING

(41) Install the overdrive shaft assembly (Fig. 289).

(42) Reinstall overdrive and reverse clutch as shown. **Rechecking these clutch clearances is not necessary.**

DISASSEMBLY AND ASSEMBLY (Continued)

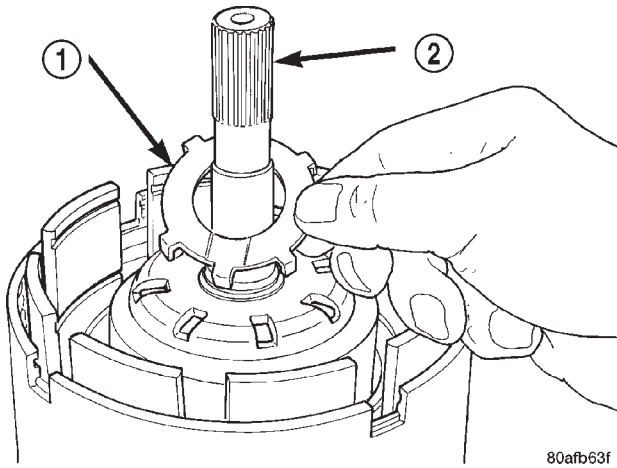

Fig. 287 Install No. 3 Thrust Washer

- 1 - #3 THRUST WASHER (NOTE 5 TABS)
- 2 - UNDERDRIVE SHAFT ASSEMBLY

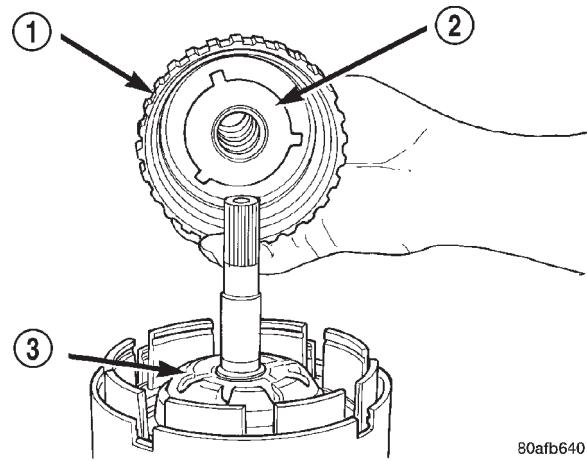

Fig. 289 Install Overdrive Shaft Assembly

- 1 - OVERDRIVE SHAFT ASSEMBLY
- 2 - #3 THRUST PLATE
- 3 - #3 THRUST WASHER

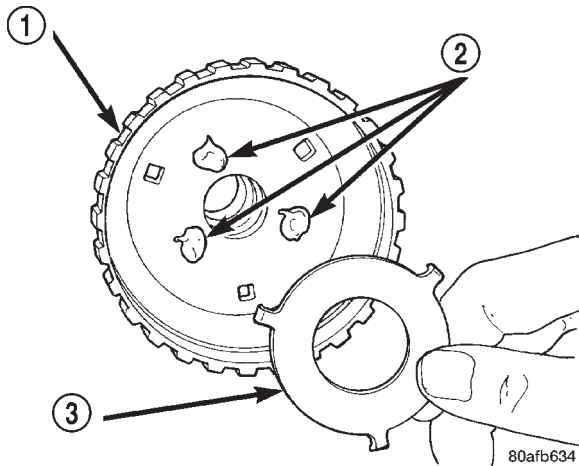

Fig. 288 Install No. 3 Thrust Plate

- 1 - OVERDRIVE SHAFT ASSEMBLY
- 2 - DABS OF PETROLATUM (FOR RETENTION)
- 3 - #3 THRUST PLATE (NOTE 3 TABS)

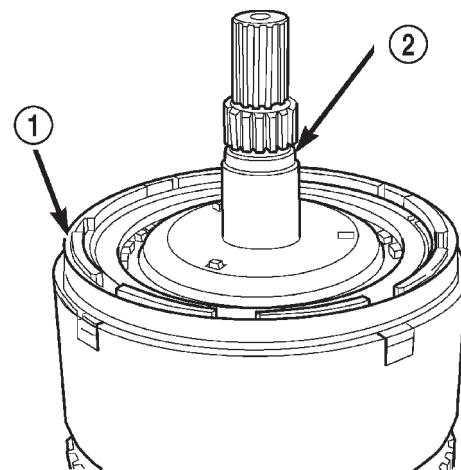

Fig. 290 Input Clutch Assembly

- 1 - INPUT CLUTCH ASSEMBLY
- 2 - OVERDRIVE SHAFT ASSEMBLY

DISASSEMBLY AND ASSEMBLY (Continued)

TRANSAXLE—ASSEMBLY

To install the output bearing cups, use Special Tool # 5050A.

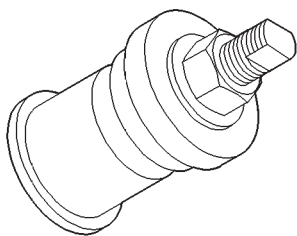

Fig. 291 Bearing Cup Installation Special Tool 5050A

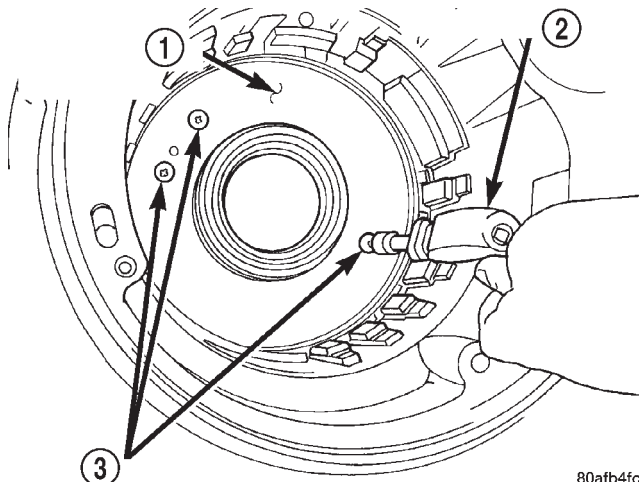

Fig. 294 Install Retainer Attaching Screws

- 1 - LOW/REVERSE CLUTCH PISTON RETAINER
- 2 - SCREWDRIVER
- 3 - TORX-LOC SCREWS

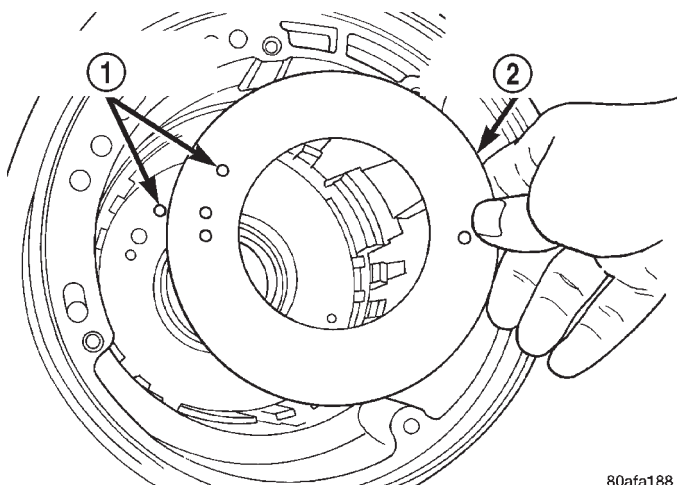

Fig. 292 Install Piston Retainer Gasket

- 1 - GASKET HOLES MUST LINE UP
- 2 - LOW/REVERSE CLUTCH PISTON RETAINER GASKET

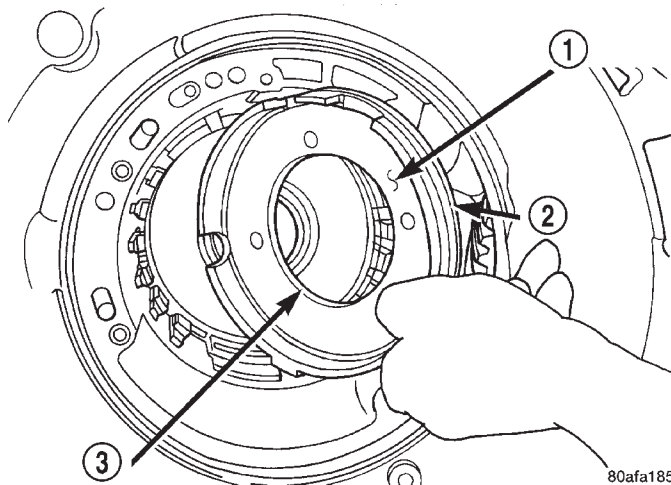

Fig. 295 Install Low/Reverse Clutch Piston

- 1 - LOW/REVERSE CLUTCH PISTON
- 2 - LIP SEAL
- 3 - LIP SEAL

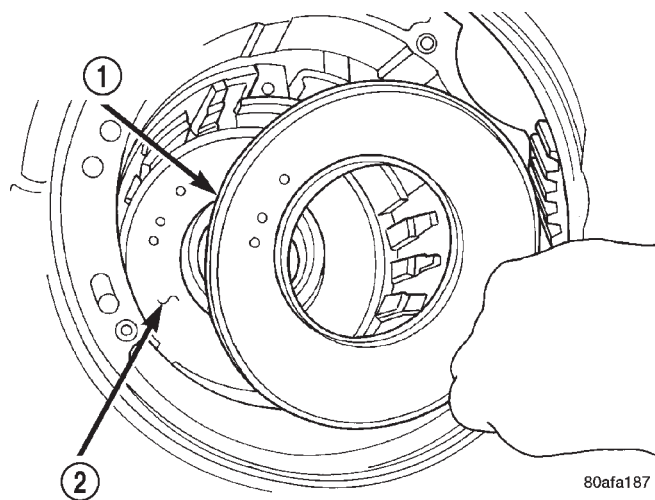

Fig. 293 Install Piston Retainer

- 1 - LOW/REVERSE CLUTCH PISTON RETAINER
- 2 - GASKET

DISASSEMBLY AND ASSEMBLY (Continued)

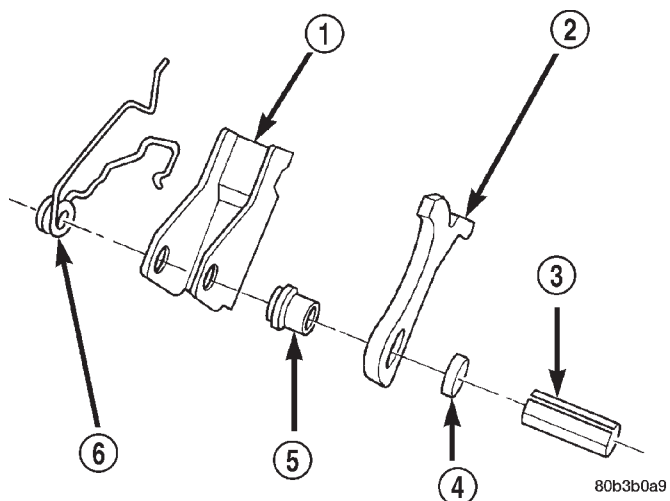

Fig. 296 Guide Bracket Disassembled

- 1 - GUIDE BRACKET
- 2 - PAWL
- 3 - SPLIT SLEEVE
- 4 - SPACER
- 5 - STEPPED SPACER
- 6 - ANTIRATCHET SPRING

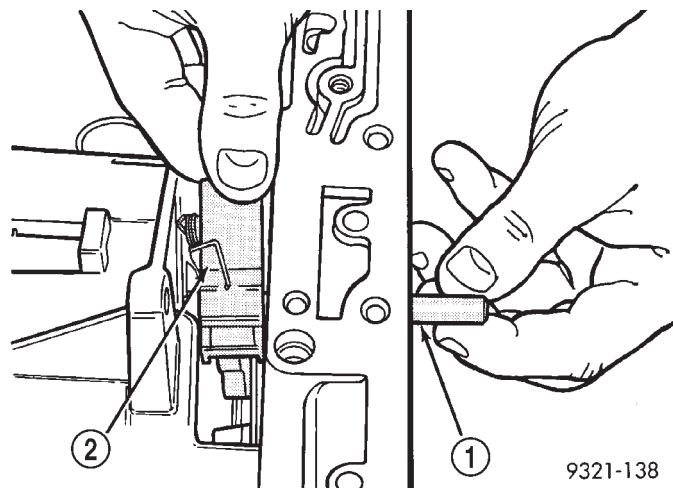

Fig. 298 Install Guide Bracket Pivot Shaft

- 1 - PIVOT PIN
- 2 - GUIDE BRACKET ASSEMBLY

CAUTION: When installing, be sure guide bracket and split sleeve touch the rear of the transaxle case.

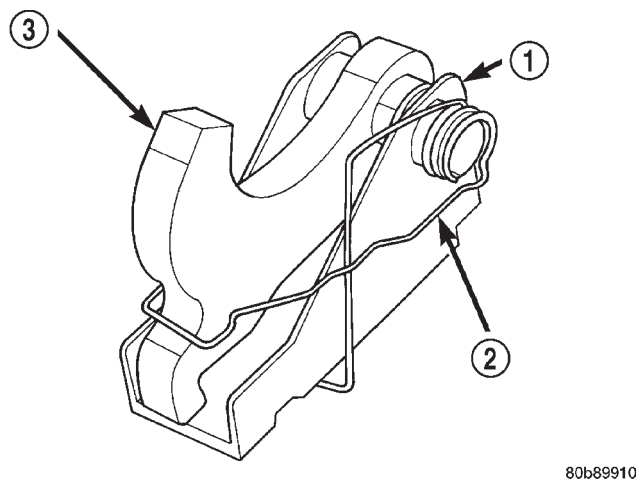

Fig. 297 Guide Bracket

- 1 - GUIDE BRACKET
- 2 - ANTIRATCHET SPRING (MUST BE ASSEMBLED AS SHOWN)
- 3 - PAWL

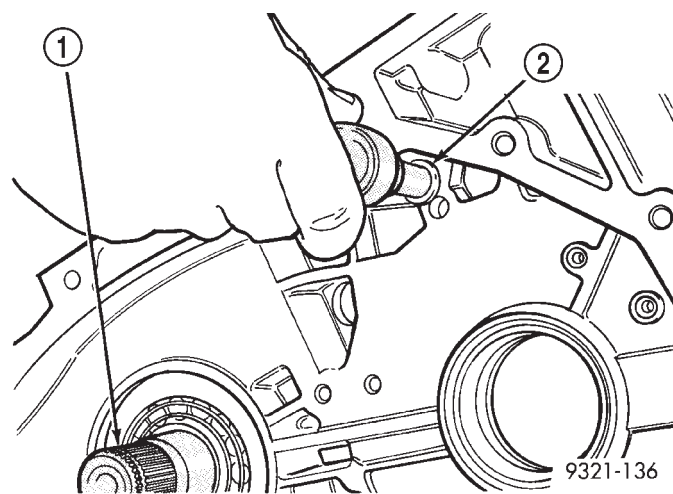
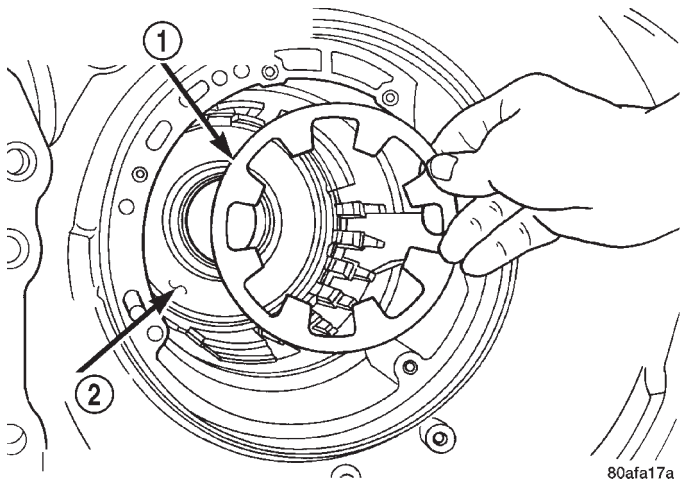

Fig. 299 Install Parking Sprag Pivot Retaining Screw

- 1 - TRANSFER SHAFT
- 2 - PARKING SPRAG PIVOT RETAINING SCREW

DISASSEMBLY AND ASSEMBLY (Continued)



80afa17a

Fig. 300 Install Low/Reverse Piston Return Spring

- 1 - LOW/REVERSE PISTON RETURN SPRING
- 2 - PISTON

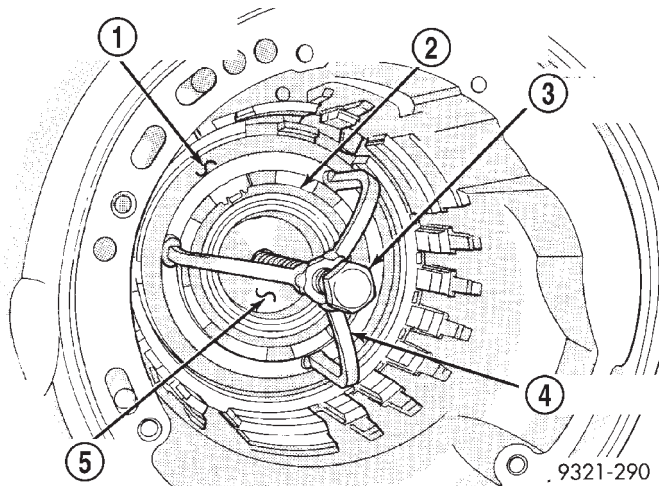

.9321-290

Fig. 302 Compressor Tool in Use

- 1 - LOW/REVERSE CLUTCH RETURN SPRING
- 2 - SNAP RING (INSTALL AS SHOWN)
- 3 - TOOL 5058A-3
- 4 - TOOL 5059A
- 5 - SPECIAL TOOL 6057

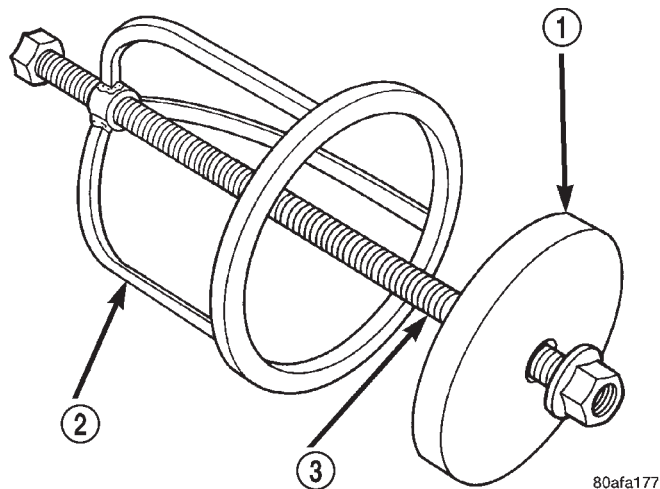

80afa177

Fig. 301 Low/Reverse Spring Compressor Tool

- 1 - TOOL 6057
- 2 - TOOL 5059
- 3 - TOOL 5058-3

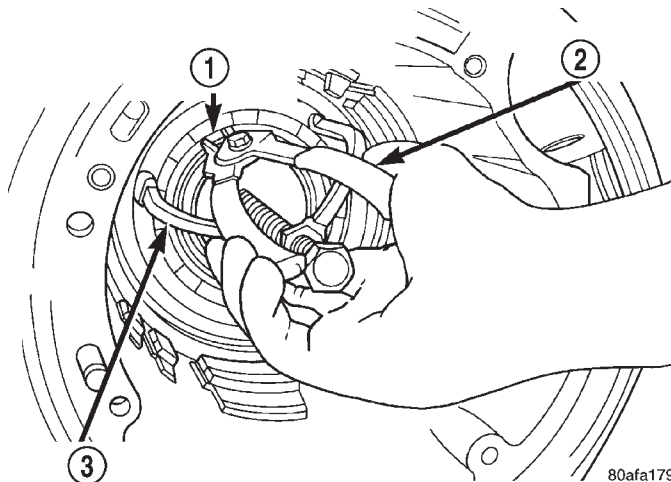

80afa179

Fig. 303 Install Snap Ring

- 1 - SNAP RING OPENING MUST BE BETWEEN SPRING LEVERS (AS SHOWN)
- 2 - SNAP RING PLIERS
- 3 - TOOL 6057

DISASSEMBLY AND ASSEMBLY (Continued)

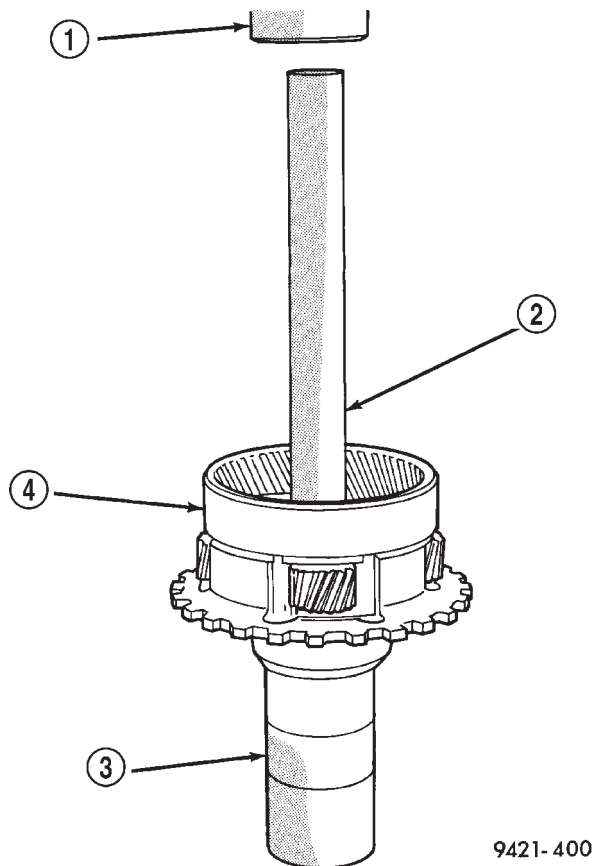

Fig. 304 Install Rear Carrier Front Bearing Cone

- 1 - ARBOR PRESS
- 2 - SPECIAL TOOL C-4171
- 3 - SPECIAL TOOL 6052
- 4 - REAR CARRIER

OUTPUT SHAFT BEARING PRELOAD SHIM SELECTION

When assembling, the output bearing preload must be checked and/or adjusted if any of the following items have been replaced:

- Output shaft (rear carrier assembly)
- Output shaft bearings
- Transaxle case

SHIM SELECTION

- (1) Install rear output shaft bearing cone and special tool 6618A (Fig. 305).
- (2) Install special tool 6618A (Fig. 306). Lightly tighten retaining screws. Screws should be below the plate surface, but do not snug screws.
- (3) Turn case over on arbor press so that the plate is resting on the press base

CAUTION: The output shaft will extend through the hole of tool 6618A. Ensure your press table has clearance for the output shaft.

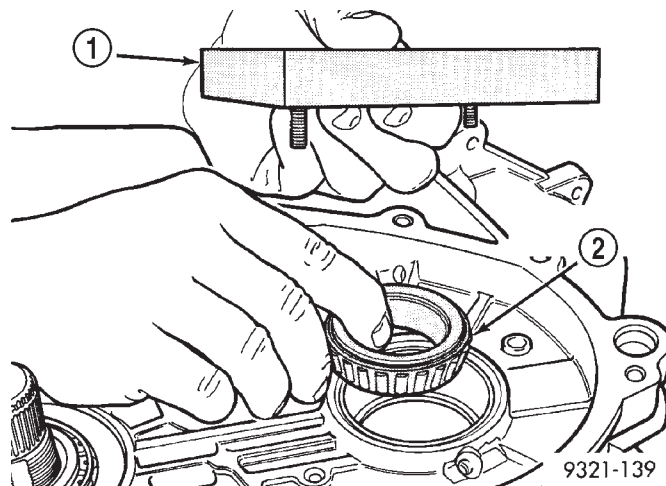

Fig. 305 Bearing Installation

- 1 - SPECIAL TOOL 6618-A
- 2 - REAR OUTPUT SHAFT BEARING

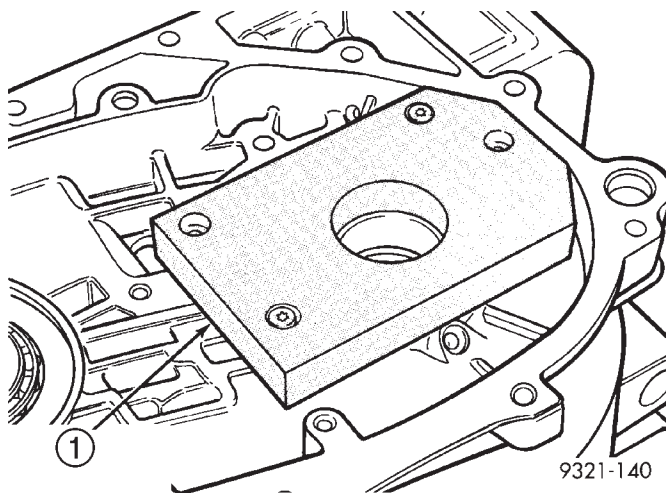

Fig. 306 Special Tool Installed

- 1 - SPECIAL TOOL 6618-A

(4) Install shim on output shaft (Fig. 307). Apply small amount of petrolatum onto the shim to hold it in place. Use the original shim as a starting point. If original shim is not available, use the thickest shim available. Refer to Output Shaft Rear Shim Chart for available sizes.

(5) Install output shaft/rear carrier into rear bearing. The shaft must be pressed into position. Use special tool MD-998911 (Disc) and C- 4171 and C4171-2 (Handle) to press shaft into rear bearing (Fig. 308).

CAUTION: Do not reuse old transfer shaft nut or output shaft nut because the removed stake weakens the nut flange.

(6) Using special tools 6497 and 6498, install new output shaft nut. Do not reuse old output shaft nut.

DISASSEMBLY AND ASSEMBLY (Continued)

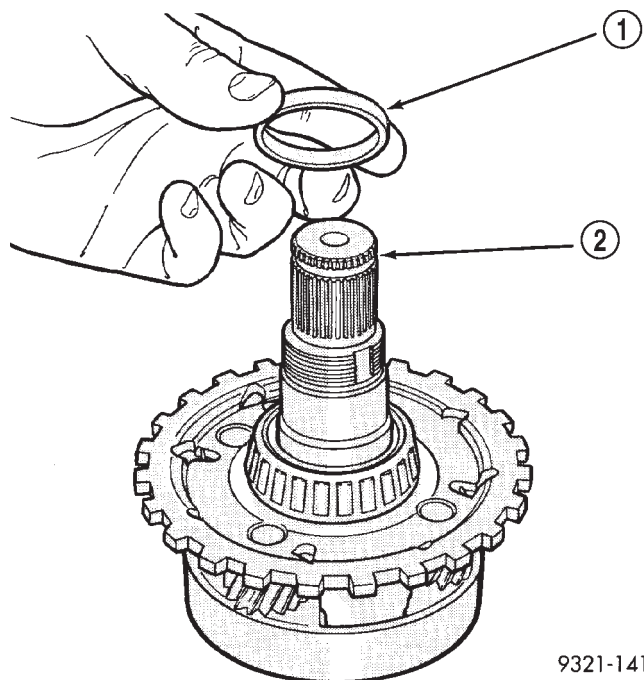

9321-141

Fig. 307 Shim Installation

- 1 - SHIM
- 2 - OUTPUT SHAFT

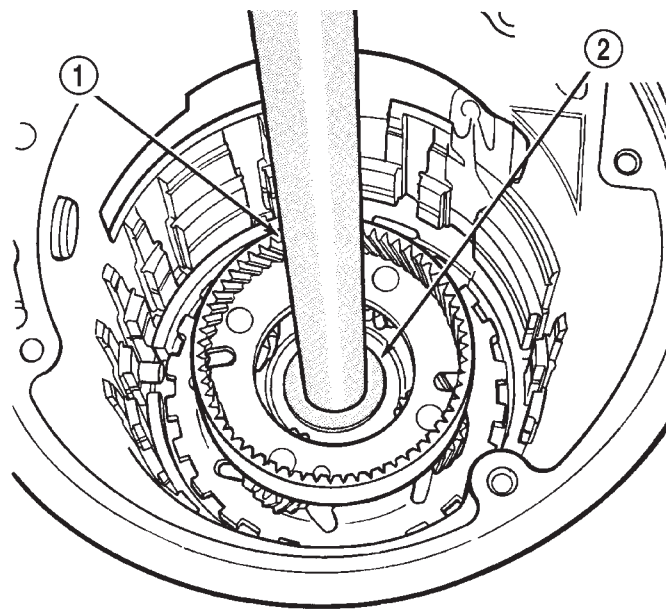

9321-142

Fig. 308 Press Shaft Into Case

- 1 - SPECIAL TOOL C-4171 AND C-4171-2
- 2 - SPECIAL TOOL MD-998911

5.17 - 5.19 mm	5.62 - 5.64 mm
5.20 - 5.22 mm	5.65 - 5.67 mm
5.23 - 5.25 mm	5.68 - 5.70 mm
5.26 - 5.28 mm	5.71 - 5.73 mm
5.29 - 5.31 mm	5.74 - 5.76 mm
5.32 - 5.34 mm	5.77 - 5.79 mm
5.35 - 5.37 mm	5.80 - 5.82 mm
5.38 - 5.40 mm	5.83 - 5.85 mm
5.41 - 5.43 mm	5.86 - 5.88 mm
5.44 - 5.46 mm	5.89 - 5.91 mm
5.47 - 5.49 mm	5.92 - 5.94 mm
5.50 - 5.52 mm	5.95 - 5.97 mm
5.53 - 5.55 mm	5.98 - 6.00 mm
5.56 - 5.58 mm	6.01 - 6.03 mm
5.59 - 5.61 mm	6.04 - 6.06 mm

Output Shaft Rear Shim Chart

Tighten new output shaft nut to 271 N·m (200 ft. lbs.).

(7) Check the turning torque of the output shaft (Fig. 309). The shaft should have 1 to 8 in. lbs. of turning torque. If the turning torque is **higher than** 8 in. lbs., install a thicker shim. If the turning torque is **less than** 1 in. lb., install a thinner shim. Make sure there is no end play.

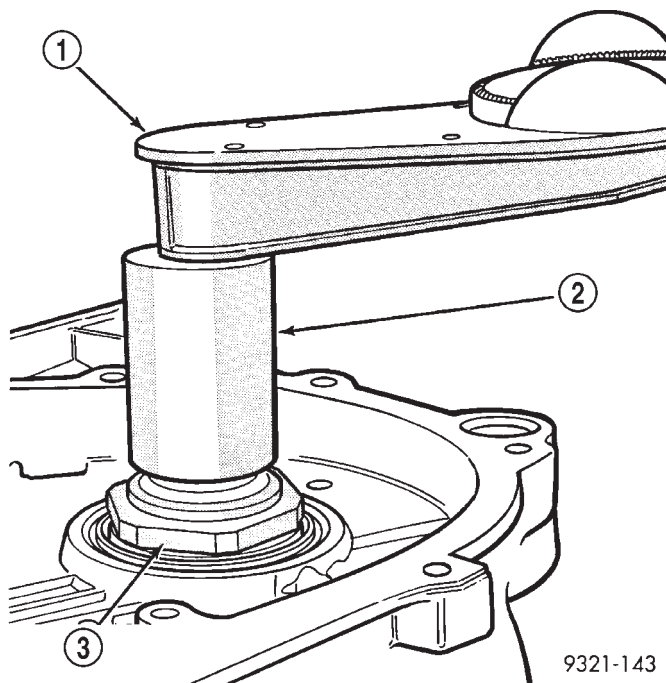

9321-143

Fig. 309 Checking Turning Torque

- 1 - TORQUE WRENCH
- 2 - SPECIAL TOOL 6498
- 3 - OUTPUT SHAFT NUT

CAUTION: Failure to stake shaft nuts could allow the nuts to back-off during use.

DISASSEMBLY AND ASSEMBLY (Continued)

(8) The new nut must be staked after the correct turning torque is obtained (Fig. 310). Use special tool 6639 to stake output shaft nut and special tool 6589 to stake transfer shaft.

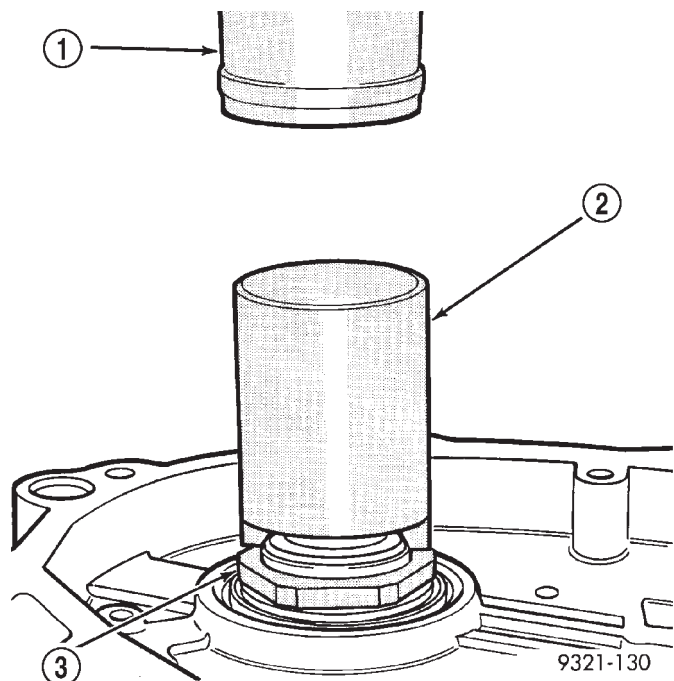

Fig. 310 Staking Output Shaft Nut

- 1 - ARBOR PRESS
- 2 - STAKING TOOL
- 3 - NEW NUT

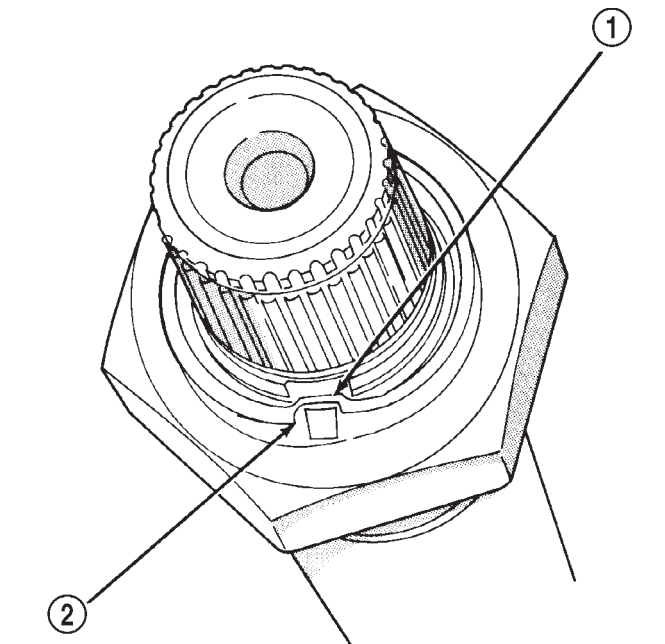

Fig. 311 Correctly Staked Nut

- 1 - BOTTOMED IN SLOT
- 2 - CORRECTLY STAKED NUT

When reinstalling main sump baffle apply Mopar Silicone Sealant as shown in (Fig. 312).

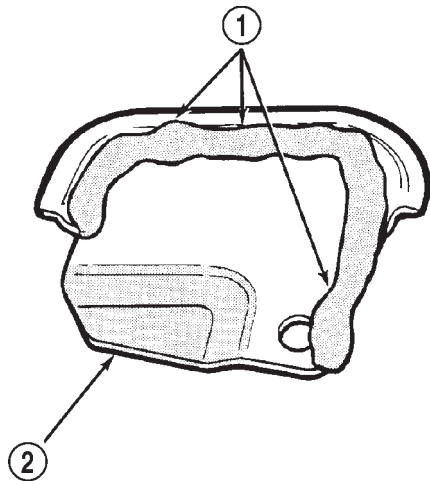

Fig. 312 Correctly Applied Sealant

- 1 - SEALANT
- 2 - BACK SIDE OF VENT BAFFLE

Install main sump baffle to transaxle case (Fig. 313).

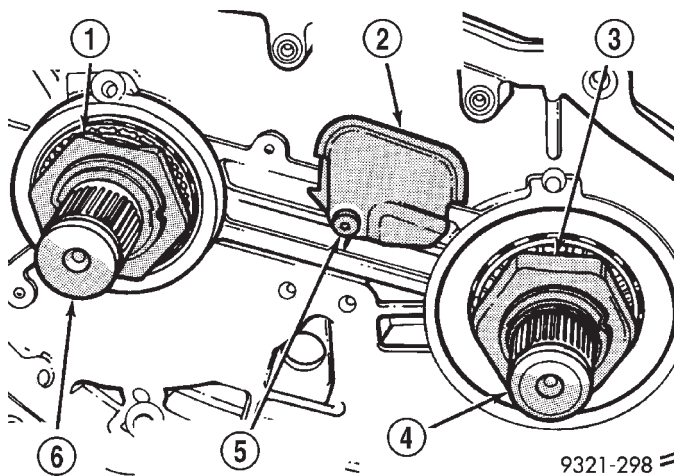

Fig. 313 Main Sump Vent Baffle Location

- 1 - OUTPUT SHAFT NUT
- 2 - MAIN SUMP VENT BAFFLE
- 3 - TRANSFER SHAFT NUT
- 4 - TRANSFER SHAFT
- 5 - VENT BAFFLE RETAINING SCREW
- 6 - OUTPUT SHAFT

CAUTION: When reinstalling drive chains, the blue link must face outward.

CAUTION: The chain sprockets have a slip fit onto the shafts. Apply only a slight amount of pressure to the chain spreader to release the chain pressure. If chain sprockets are not spread slightly, installation will be difficult.

DISASSEMBLY AND ASSEMBLY (Continued)

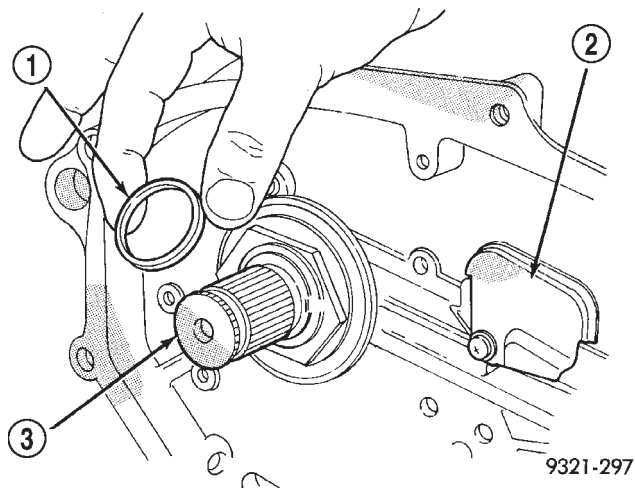

9321-297

Fig. 314 Output Sprocket Spacer

- 1 - OUTPUT SPROCKET SPACER
- 2 - VENT BAFFLE
- 3 - OUTPUT SHAFT

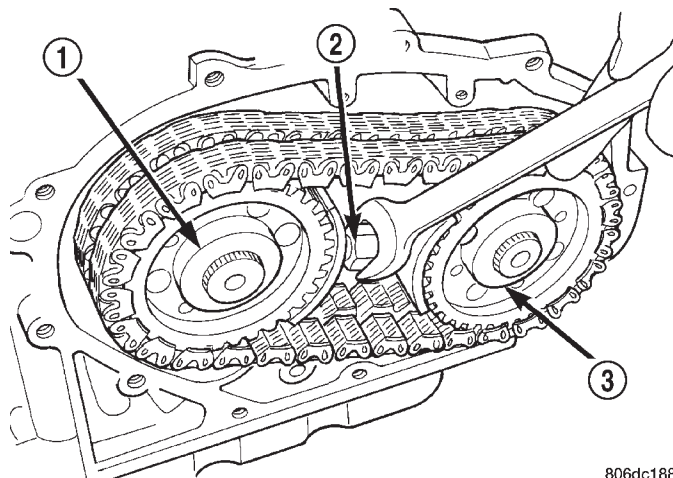

806dc188

Fig. 316 Remove Chain Spreader

- 1 - OUTPUT SPROCKET
- 2 - SPECIAL TOOL 6550
- 3 - TRANSFER SPROCKET

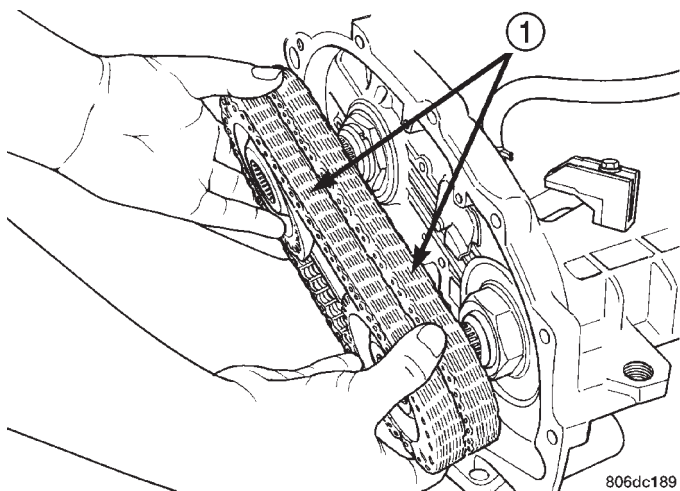

806dc189

Fig. 315 Install Chains and Both Sprockets as an Assembly

- 1 - CHAINS

CAUTION: Be sure to reinstall the chain snubber and chain oiler when reassembling.

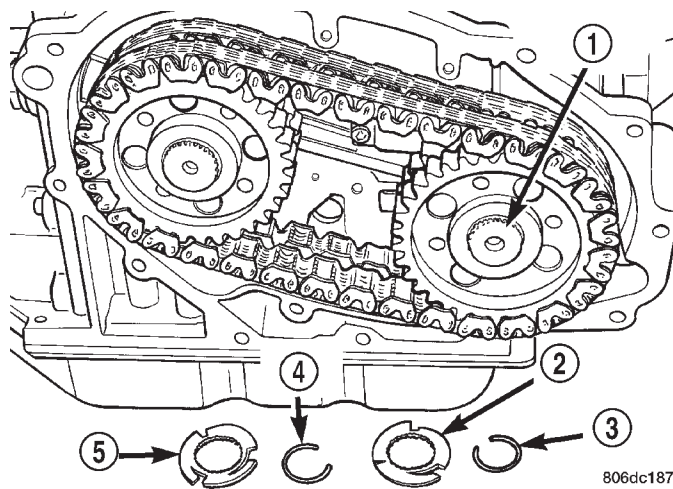

806dc187

Fig. 317 Install Transfer Shaft Sprocket Snap Ring and Wave Washer

- 1 - TRANSFER SHAFT
- 2 - WAVE WASHER
- 3 - SNAP RING
- 4 - SNAP RING
- 5 - WAVE WASHER

DISASSEMBLY AND ASSEMBLY (Continued)

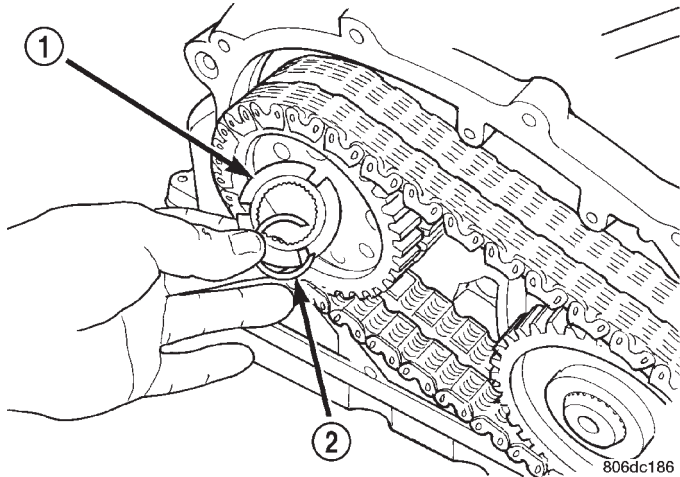

Fig. 318 Install Output Shaft Sprocket Snap Ring and Wave Washer

- 1 - WAVE WASHER
- 2 - SNAP RING

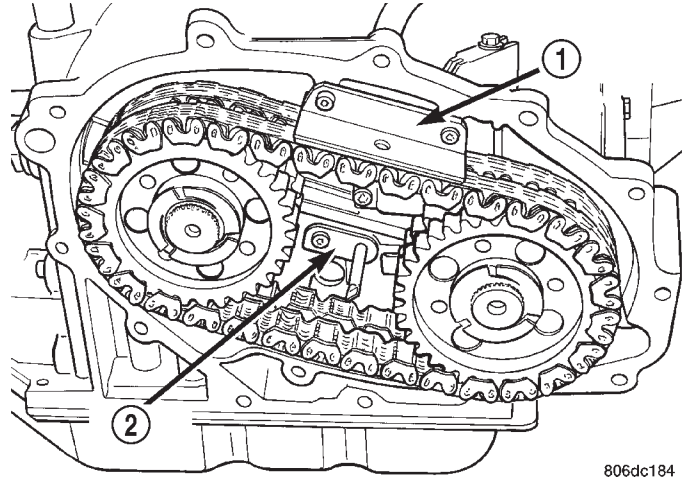

Fig. 320 Install Chain Oiler

- 1 - CHAIN SNUBBER
- 2 - CHAIN OILER

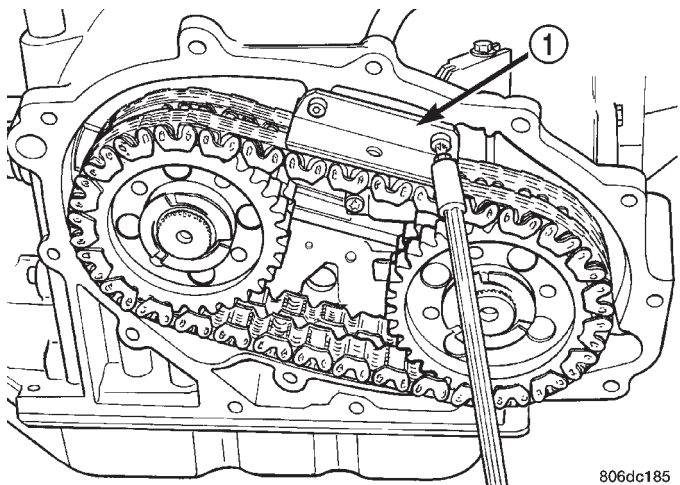

Fig. 319 Install Chain Snubber

- 1 - CHAIN SNUBBER

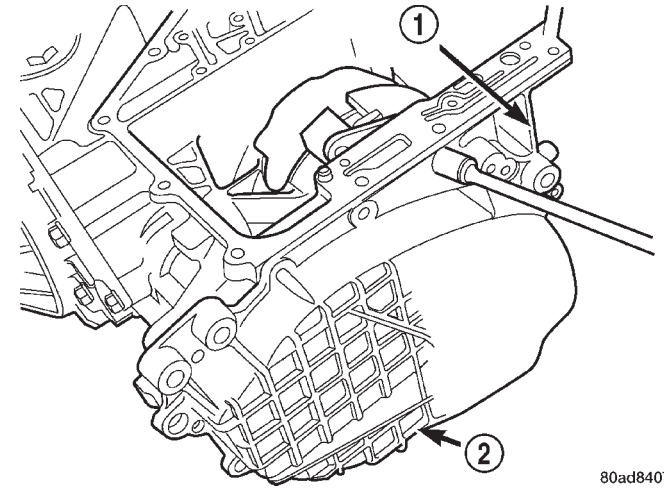

Fig. 321 Install Chain Cover

- 1 - TRANSAXLE CASE
- 2 - CHAIN COVER

Stand trans upright on bellhousing

Chain cover must be free of old sealant, dirt and oil before applying new sealant. Apply a 1/8 inch bead of sealant to flange of cover.

DISASSEMBLY AND ASSEMBLY (Continued)

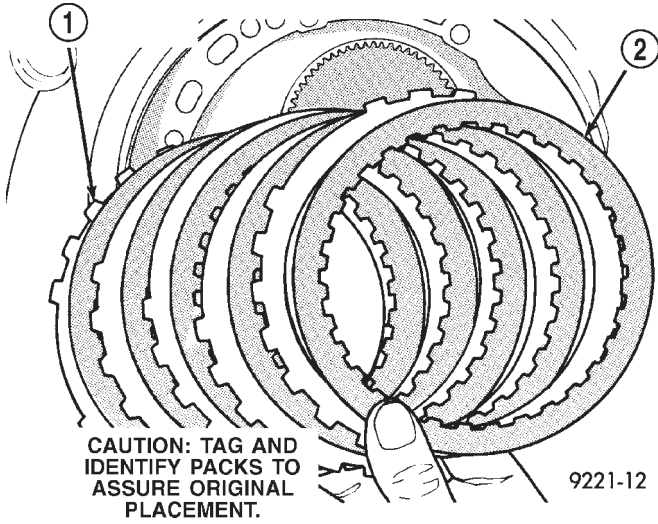

Fig. 322 Install Low/Reverse Clutch Pack

- 1 - CLUTCH PLATES (5)
- 2 - CLUTCH DISCS (5)

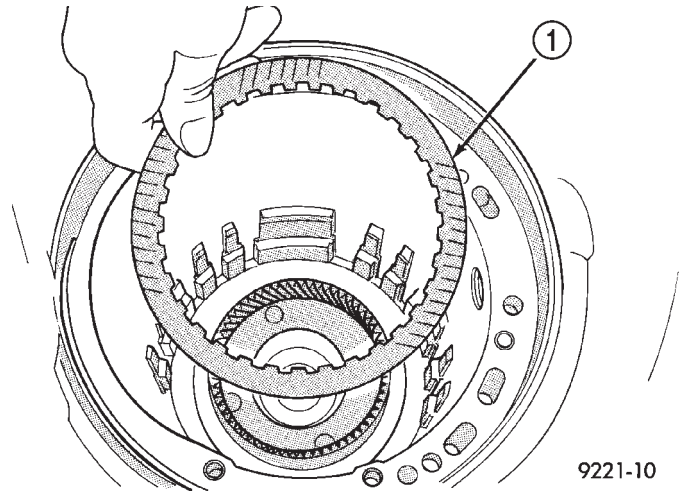

Fig. 324 Install One Disc

- 1 - ONE DISC FROM LOW/REVERSE CLUTCH

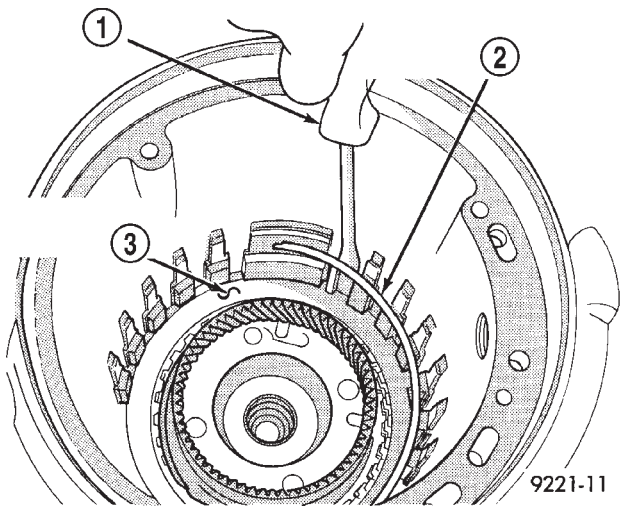

Fig. 323 Install Low/Reverse Reaction Plate Snap Ring

- 1 - SCREWDRIVER
- 2 - LOW/REVERSE REACTION PLATE FLAT SNAP RING
- 3 - DO NOT SCRATCH CLUTCH PLATE

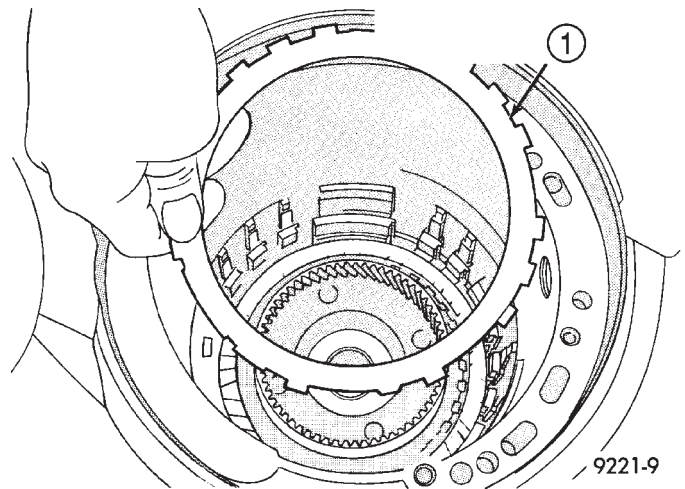

Fig. 325 Install Low/Reverse Reaction Plate

- 1 - LOW/REVERSE REACTION PLATE (FLAT SIDE UP)

DISASSEMBLY AND ASSEMBLY (Continued)

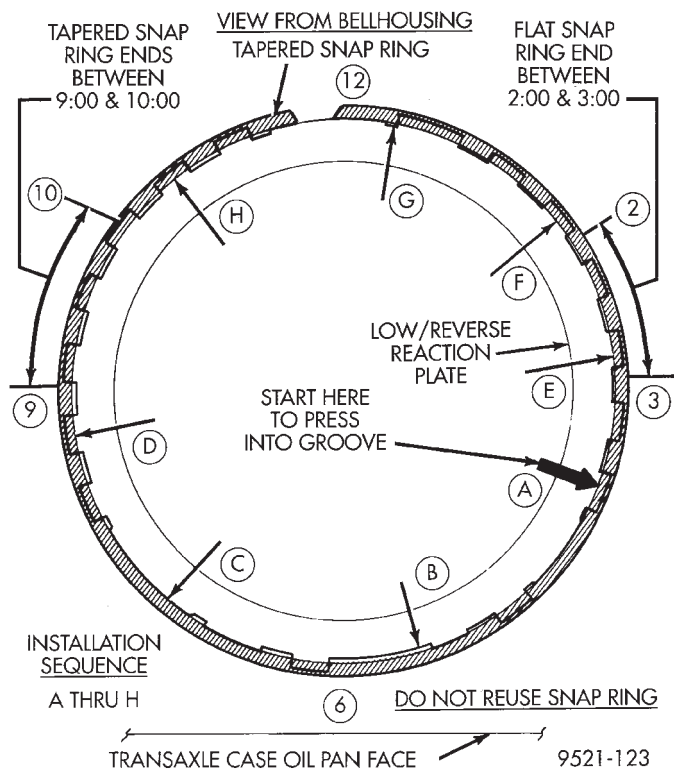

Fig. 326 Tapered Snap Ring Instructions

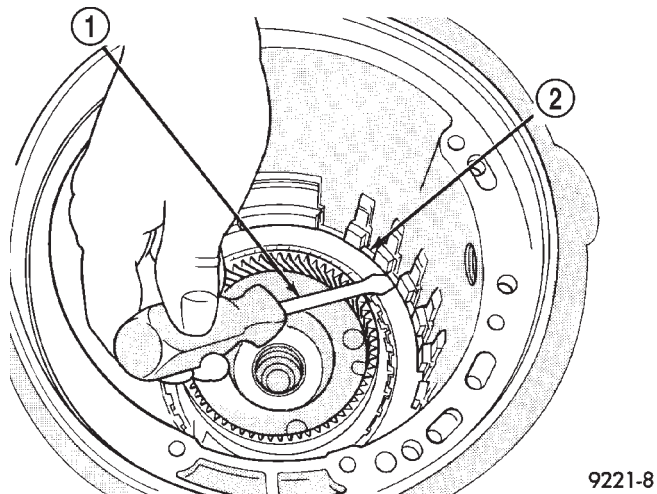

Fig. 327 Snap Ring Installed

- 1 - SCREWDRIVER
- 2 - TAPERED SNAP RING (INSTALL AS SHOWN)

Press down clutch pack with finger and zero dial indicator. **Low/Reverse clutch pack clearance is 0.86 to 1.52 (.034 to .060 inch).**

Select the proper low/reverse reaction plate to achieve specifications:

NOTE: When installing the 2-4 clutch plates and discs, the orientation should be alternated so the pilot pads of adjacent plates do not align, refer to (Fig. 330).

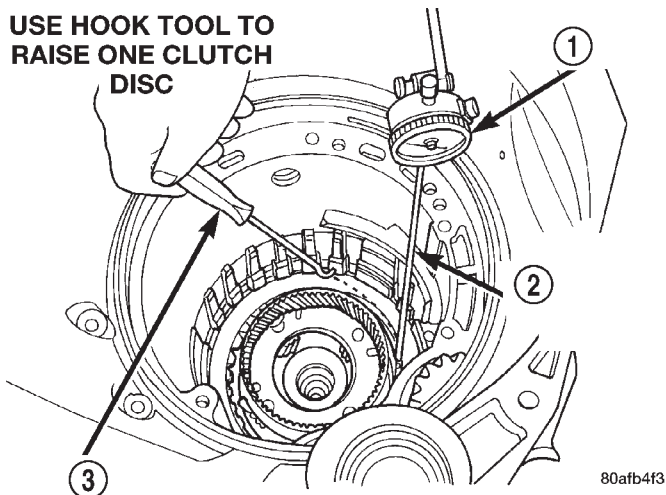
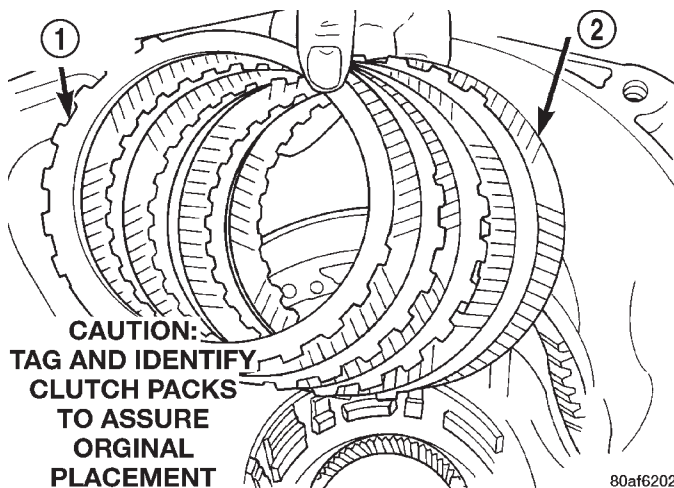

Fig. 328 Check Low/Reverse Clutch Clearance

- 1 - DIAL INDICATOR
- 2 - DIAL INDICATOR TIP TOOL 6268
- 3 - HOOK TOOL

LOW/REVERSE REACTION PLATE CHART

PART NUMBER	THICKNESS
4799846AA	5.88 mm (.232 in.)
4799847AA	6.14 mm (.242 in.)
4799848AA	6.40 mm (.252 in.)
4799849AA	6.66 mm (.262 in.)
4799855AA	6.92 mm (.273 in.)



CAUTION:
TAG AND IDENTIFY
CLUTCH PACKS
TO ASSURE
ORIGINAL
PLACEMENT

Fig. 329 Install 2/4 Clutch Pack

- 1 - CLUTCH PLATE (4)
- 2 - CLUTCH DISC (4)

DISASSEMBLY AND ASSEMBLY (Continued)

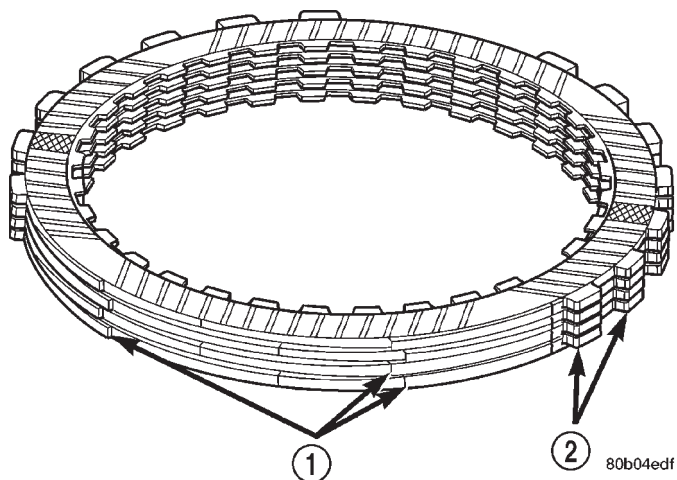

Fig. 330 Stagger 2/4 Clutch Plate Pads

- 1 - PILOT PADS
- 2 - LUGS

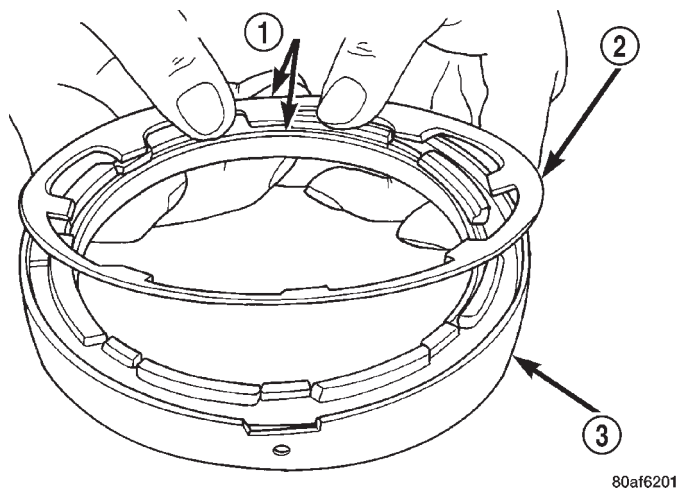

Fig. 332 Proper Orientation of 2/4 Clutch Retainer and Spring

- 1 - NOTE POSITION
- 2 - RETURN SPRING
- 3 - 2/4 CLUTCH RETAINER

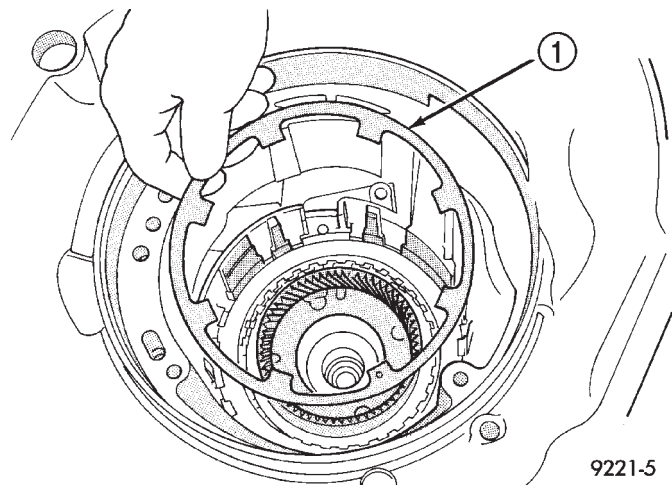

Fig. 331 Install 2/4 Clutch Return Spring

- 1 - 2/4 CLUTCH RETURN SPRING

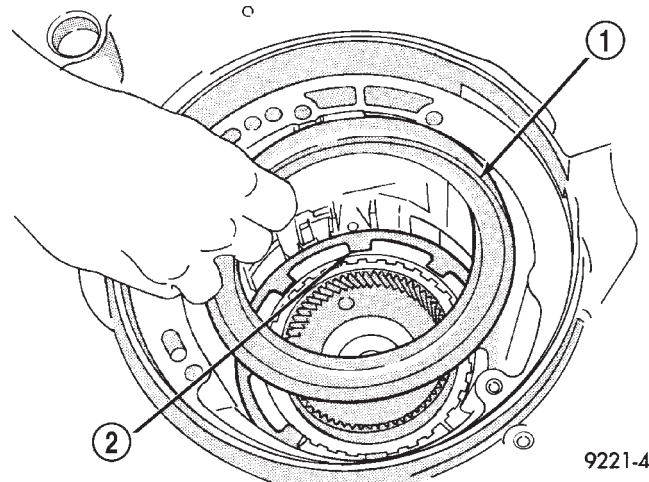

Fig. 333 Install 2/4 Clutch Retainer

- 1 - 2/4 CLUTCH RETAINER
- 2 - 2/4 CLUTCH RETURN SPRING

DISASSEMBLY AND ASSEMBLY (Continued)

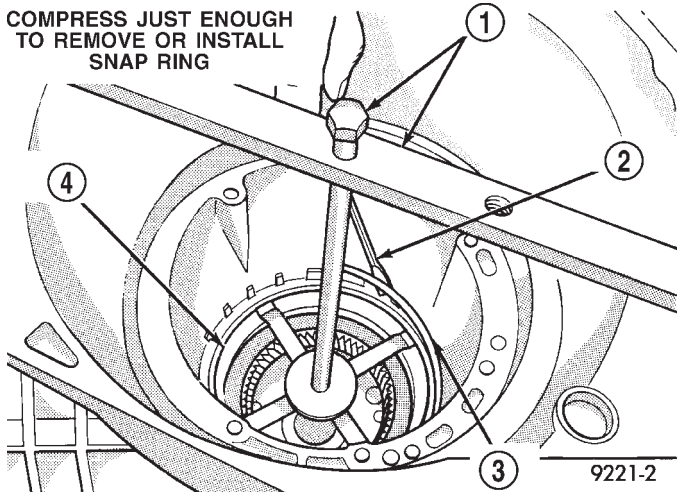

Fig. 334 Install 2/4 Clutch Retainer Snap Ring

- 1 - TOOL 5058
- 2 - SCREWDRIVER
- 3 - SNAP RING
- 4 - 2/4 CLUTCH RETAINER

The number 7 needle bearing has three antireversal tabs and is common with the number 5 and number 2 position. The orientation should allow the bearing to seat flat against the rear sun gear (Fig. 336). A small amount of petrolatum can be used to hold the bearing to the rear sun gear.

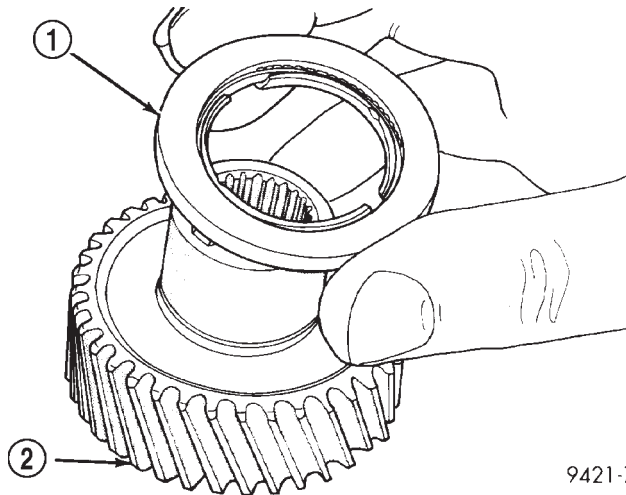

Fig. 336 Number 7 Bearing

- 1 - #7 BEARING
- 2 - REAR SUN GEAR

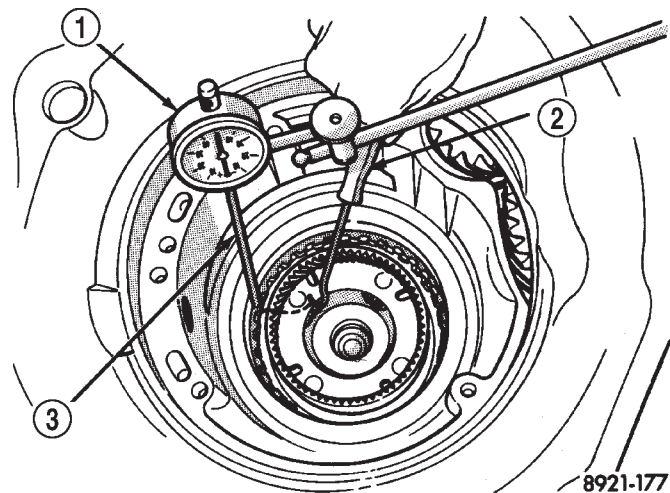

Fig. 335 Check 2/4 Clutch Clearance

- 1 - DIAL INDICATOR
- 2 - HOOK TOOL
- 3 - DIAL INDICATOR TIP TOOL 6268

Press down clutch pack with finger and zero dial indicator. **The 2/4 clutch pack clearance is 0.76 to 2.64 mm (.030 to .104 inch).** If not within specifications, the clutch is not assembled properly. **There is no adjustment for the 2/4 clutch clearance.**

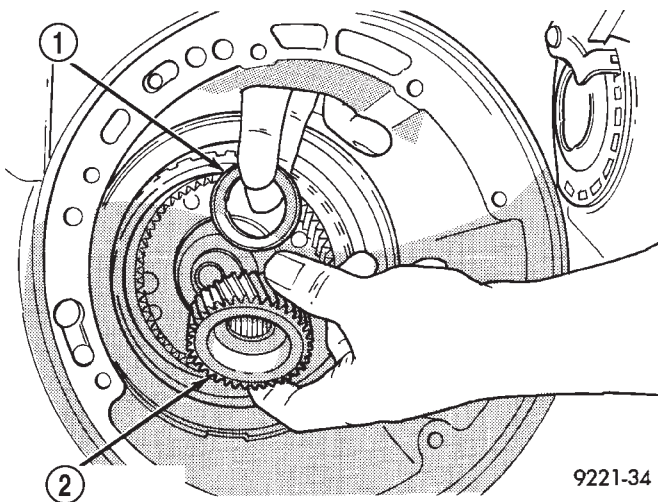
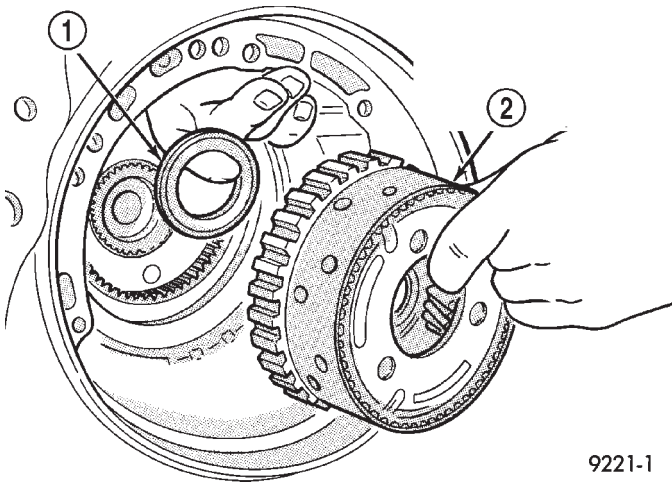

Fig. 337 Install Rear Sun Gear

- 1 - #7 NEEDLE BEARING
- 2 - REAR SUN GEAR

DISASSEMBLY AND ASSEMBLY (Continued)



9221-1

Fig. 338 Install Front Carrier and Rear Annulus Assembly

- 1 - #6 NEEDLE BEARING
- 2 - FRONT CARRIER AND REAR ANNULUS ASSEMBLY (TWIST AND PULL OR PUSH TO REMOVE OR INSTALL).

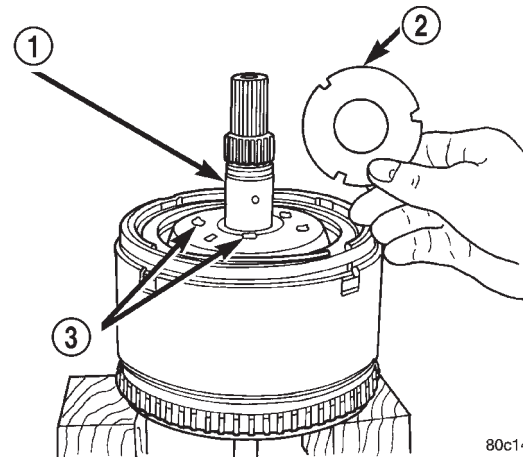

80c140f6

Fig. 340 Select Thinnest No. 4 Thrust Plate

- 1 - OVERDRIVE SHAFT ASSEMBLY
- 2 - #4 THRUST PLATE (SELECT)
- 3 - 3 DABS OF PETROLATUM FOR RETENTION

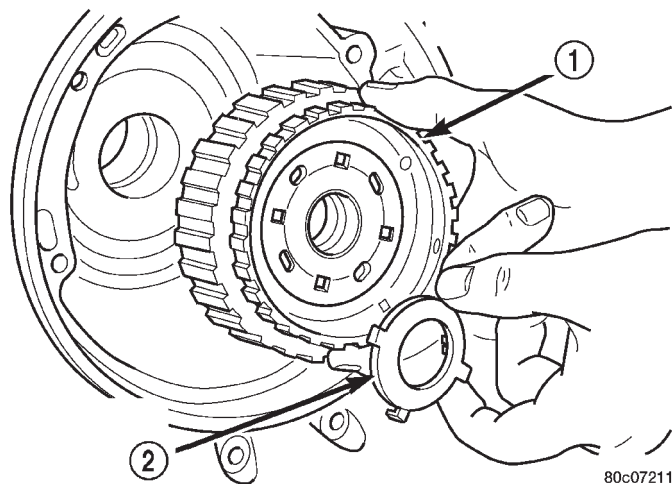

80c07211

Fig. 339 Install Front Sun Gear Assembly

- 1 - FRONT SUN GEAR ASSEMBLY
- 2 - #4 THRUST WASHER (FOUR TABS)

DETERMINING No. 4 THRUST PLATE THICKNESS—INPUT SHAFT END PLAY

To determine the proper thickness of the No. 4 thrust plate, select the thinnest No. 4 thrust plate. Using petrolatum (Fig. 340) to hold thrust plate in position, install input clutch assembly. Be sure the input clutch assembly is completely seated (Fig. 341).

CAUTION: If view through input speed sensor hole is not as shown above, the input clutches assembly is not seated properly.

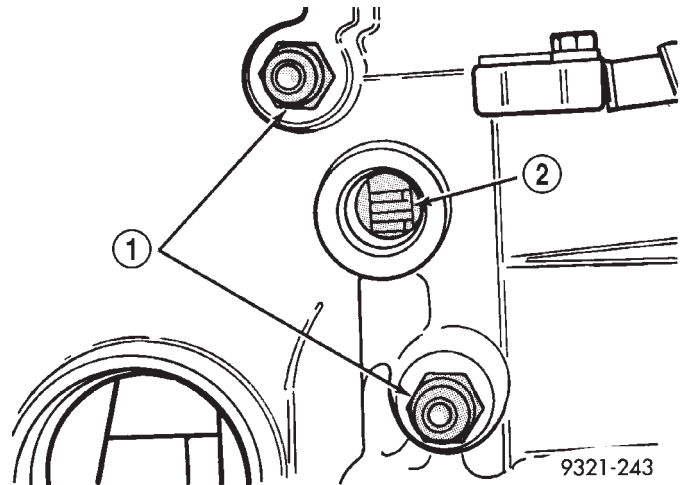

9321-243

Fig. 341 View Through Turbine Speed Sensor Hole

- 1 - TRANSAXLE COOLER LINE
- 2 - TURBINE SPEED SENSOR HOLE

Remove the oil pump O-ring (Fig. 342). You will be able to install and remove the oil pump and gasket very easily to select the proper No. 4 thrust plate.

NOTE: Use screw-in dowels or phillips-head screwdrivers to align pump to case.

CAUTION: Be sure to reinstall O-ring on oil pump after selecting the proper No. 4 thrust plate.

Measure the input shaft end play with the transaxle in the vertical position. This will ensure that the measurement will be accurate.

DISASSEMBLY AND ASSEMBLY (Continued)

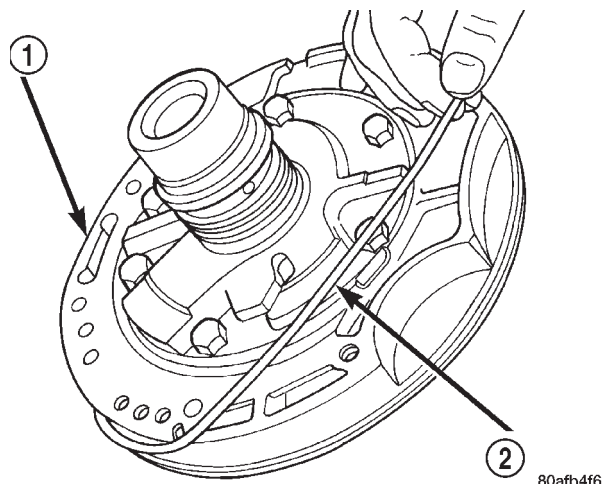

Fig. 342 Remove Oil Pump O-Ring

- 1 - OIL PUMP ASSEMBLY
- 2 - O-RING

Set up and measure endplay using End Play Set 8266 and Dial Indicator Set C3339 as shown in (Fig. 343).

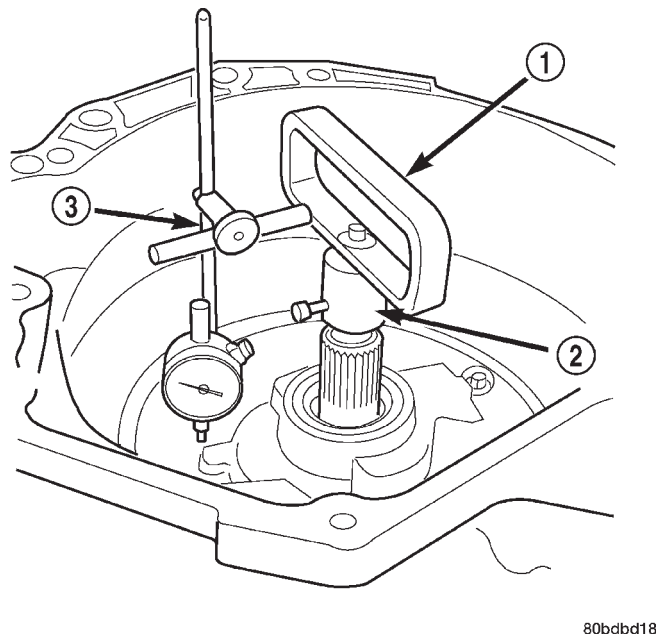

Fig. 343 Measure Input Shaft End Play using End Play Set 8266

- 1 - TOOL 8266-8
- 2 - TOOL 8266-2
- 3 - TOOL C-3339

NOTE: Input shaft end play must be .005 to .025 inch.

For example, if end play reading is .055 inch, select No. 4 Thrust Plate which is .071 to .074 thick. This should provide an input shaft end play reading of .020 inch which is within specifications.

See chart to select the proper No. 4 thrust plate.

NO. 4 THRUST PLATE CHART

PART NUMBER	THICKNESS
4431662	.91mm (.036 in.)
4431663	1.14mm (.045 in.)
4431664	1.37mm (.054 in.)
4431665	1.60mm (.063 in.)
3836237	1.73mm (.068 in.)
4431666	1.80mm (.071 in.)
3836238	1.96mm (.077 in.)
4431667	2.03mm (.080 in.)
3836239	2.16mm (.085 in.)
4431668	2.24mm (.088 in.)
3836240	2.39mm (.094 in.)
4431669	2.46mm (.097 in.)
3836241	2.62mm (.103 in.)
4446670	2.67mm (.105 in.)
4446671	2.90mm (.114 in.)
4446672	3.15mm (.124 in.)
4446601	3.38mm (.133 in.)

Reinstall the input clutches assembly with the selected thrust plate.

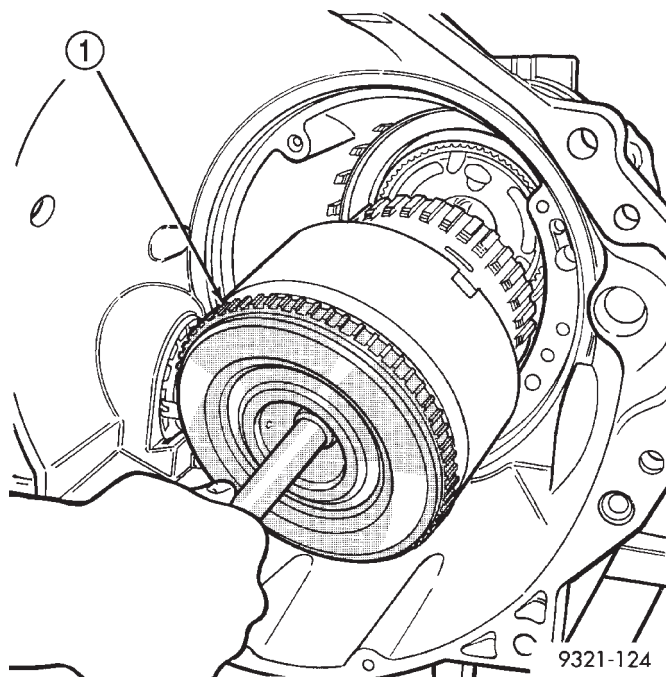
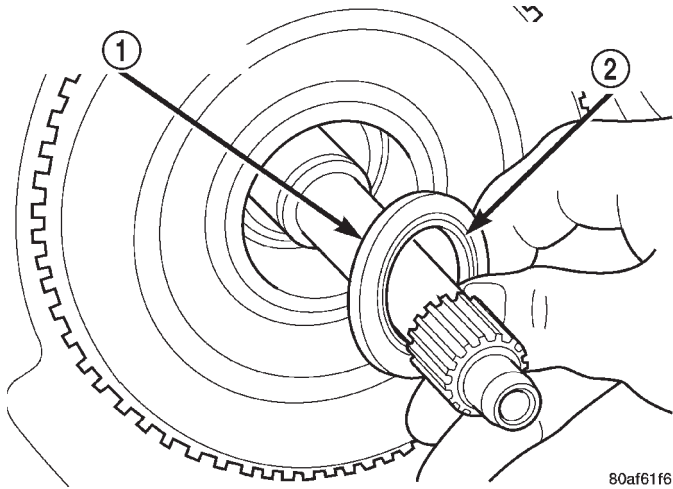

Fig. 344 Install Input Clutch Assembly

- 1 - INPUT CLUTCH ASSEMBLY

DISASSEMBLY AND ASSEMBLY (Continued)



80af61f6

Fig. 345 Install Caged Needle Bearing

- 1 - #1 CAGED NEEDLE BEARING
- 2 - NOTE: TANGED SIDE OUT

CAUTION: By-pass valve must be replaced if transmission failure occurs.

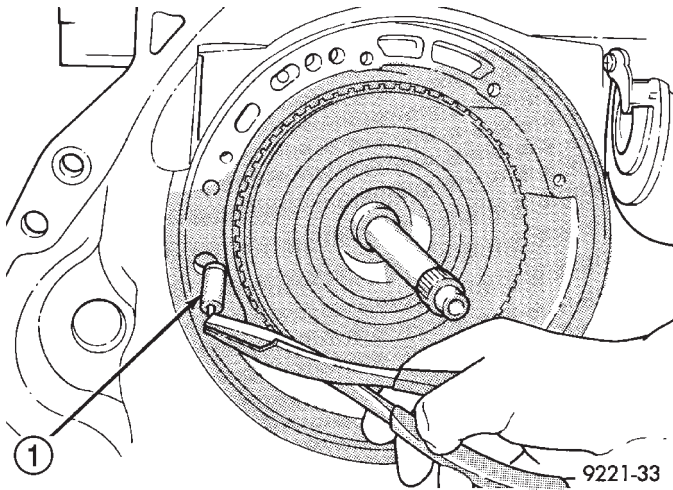

9221-33

Fig. 346 Install By-Pass Valve

- 1 - BY-PASS VALVE

NOTE: To align oil pump during installation, use threaded dowels or phillips screwdrivers.

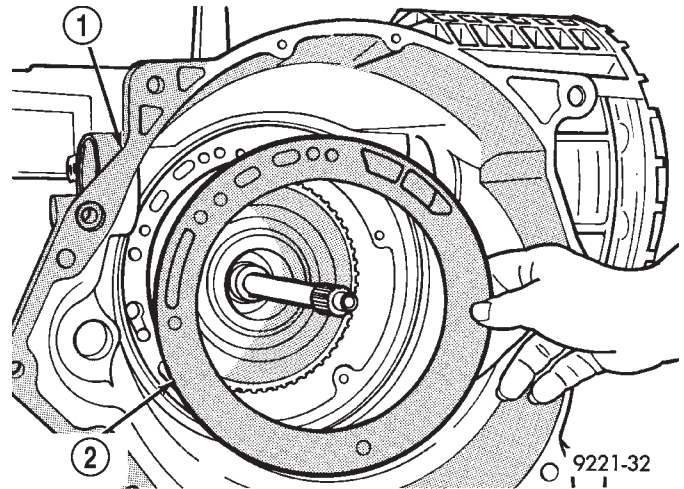

9221-32

Fig. 347 Install Oil Pump Gasket

- 1 - BELL HOUSING
- 2 - OIL PUMP GASKET

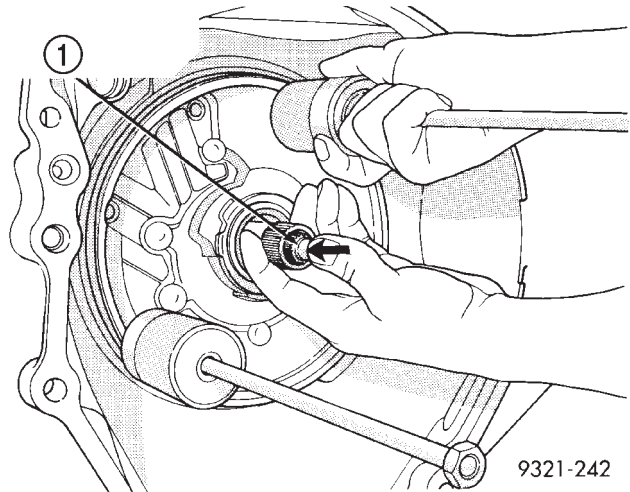

9321-242

Fig. 348 Install Oil Pump

- 1 - "PUSH IN" ON INPUT SHAFT WHILE REMOVING PUMP

DISASSEMBLY AND ASSEMBLY (Continued)

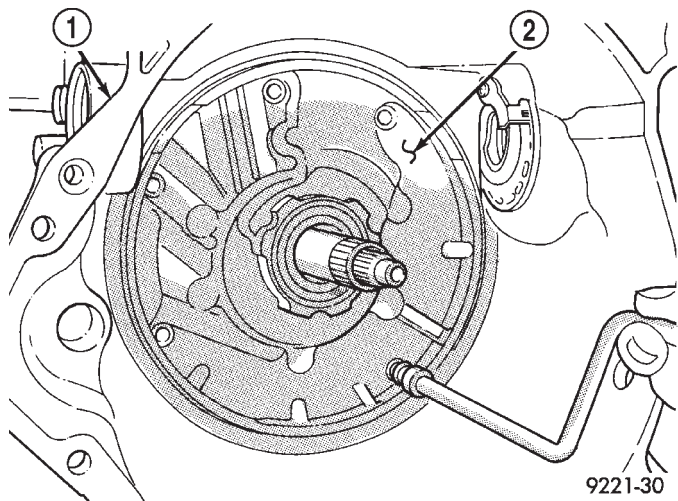

Fig. 349 Install Oil Pump Attaching Bolts

- 1 - BELLHOUSING
- 2 - OIL PUMP

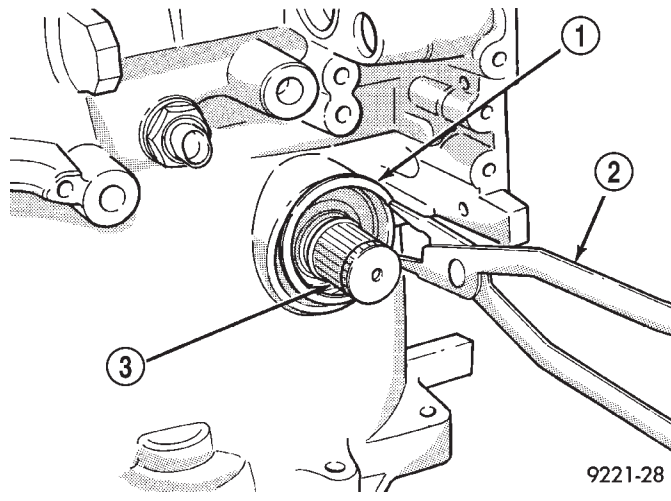

Fig. 351 Install Long Stub Shaft Snap Ring

- 1 - SNAP RING
- 2 - SNAP RING PLIERS
- 3 - LONG STUB SHAFT

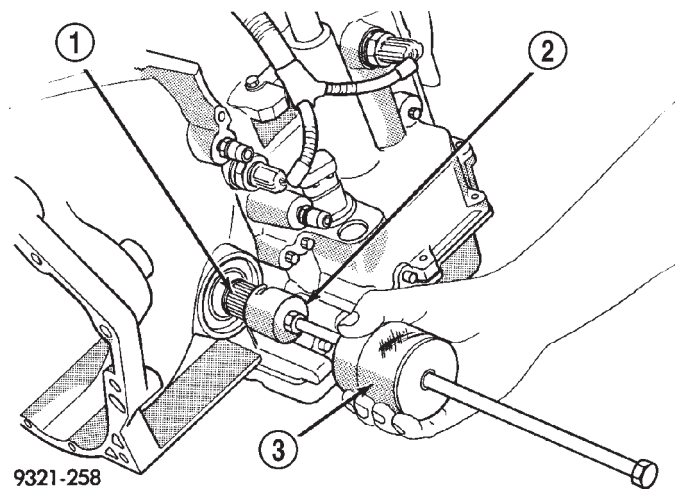

Fig. 350 Install Long Stub Shaft To Bellhousing

- 1 - LONG STUB SHAFT
- 2 - SPECIAL TOOL 6669
- 3 - SLIDE HAMMER C-3752

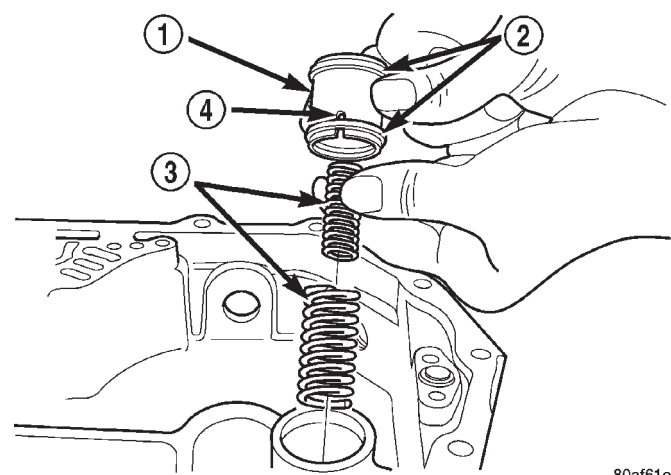
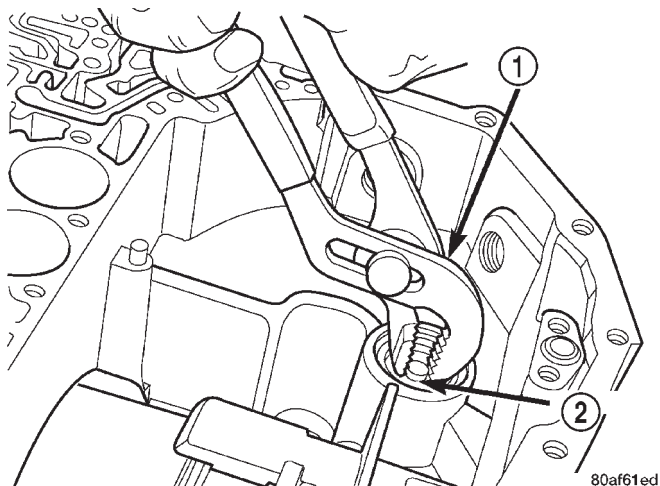

Fig. 352 Install Low/Reverse Accumulator

- 1 - ACCUMULATOR PISTON
- 2 - SEAL RINGS
- 3 - RETURN SPRINGS
- 4 - (NOTE NOTCH)

NOTE: Install new driveshaft retainer clips to drive-shafts.

DISASSEMBLY AND ASSEMBLY (Continued)



80af61ed

Fig. 353 Install Low/Reverse Accumulator Plug (Cover)

- 1 - ADJUSTABLE PLIERS
- 2 - PLUG

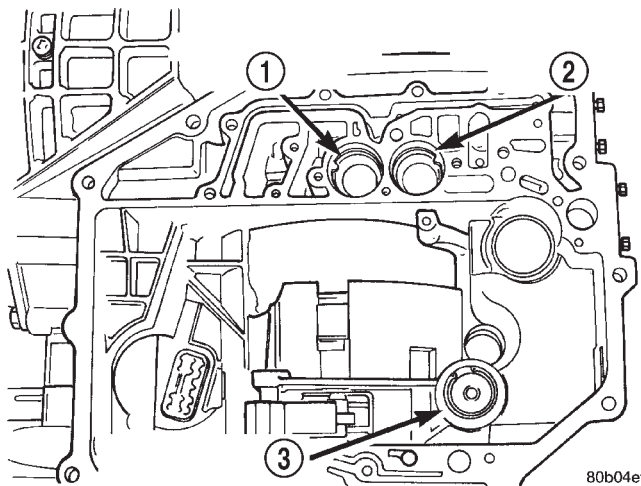

80b04ef8

Fig. 355 Accumulator Locations

- 1 - OVERDRIVE ACCUMULATOR LOCATION
- 2 - UNDERDRIVE ACCUMULATOR LOCATION
- 3 - LOW/REVERSE ACCUMULATOR

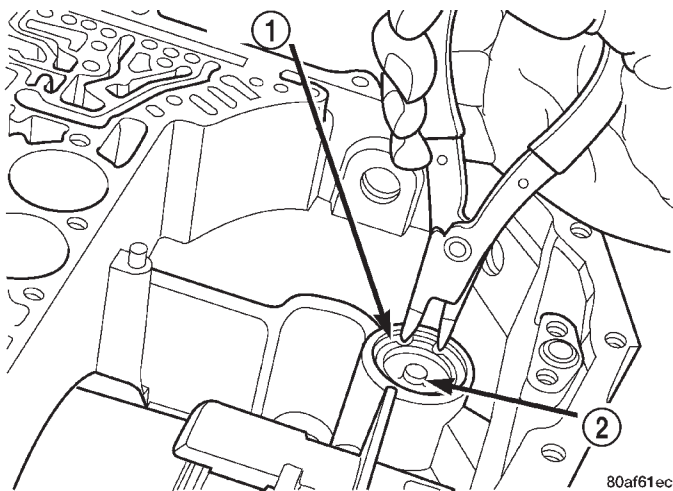

80af61ec

Fig. 354 Install Low/Reverse Accumulator Snap Ring

- 1 - SNAP RING
- 2 - PLUG

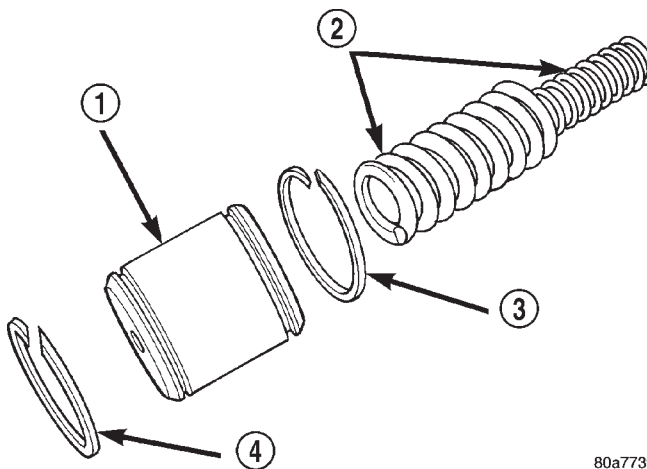

80a77399

Fig. 356 Install Underdrive Accumulator and Springs

- 1 - ACCUMULATOR PISTON (UNDERDRIVE)
- 2 - RETURN SPRINGS
- 3 - SEAL RING
- 4 - SEAL RING

DISASSEMBLY AND ASSEMBLY (Continued)

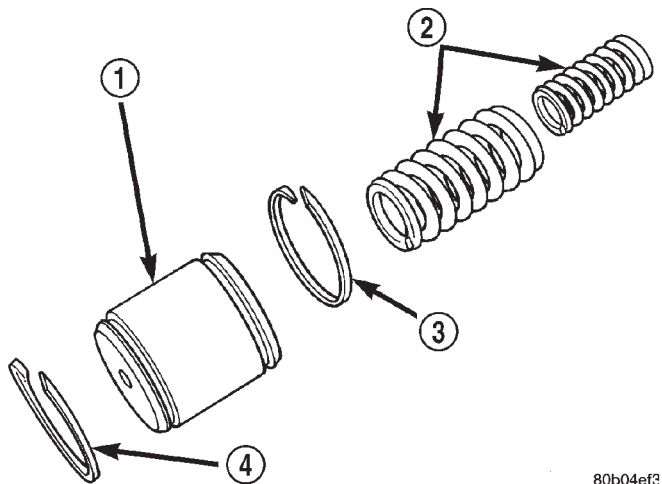

80b04ef3

Fig. 357 Install Overdrive Accumulator and Springs

- 1 - OVERDRIVE ACCUMULATOR PISTON
- 2 - RETURN SPRINGS
- 3 - SEAL RING
- 4 - SEAL RING

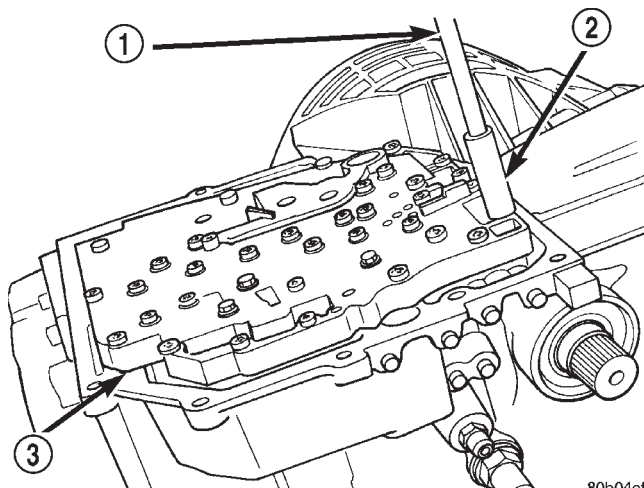

80b04ef6

Fig. 359 Install Valve Body Bolts (17)

- 1 - EXTENSION
- 2 - SOCKET
- 3 - VALVE BODY

CAUTION: Do not handle the valve body by the manual shaft. Damage could result.

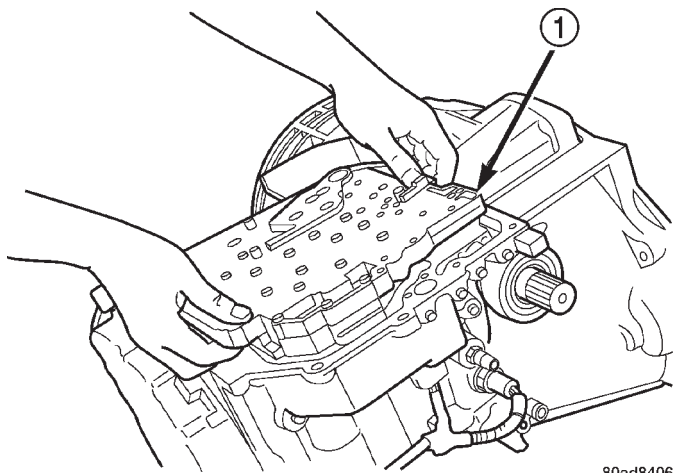

80ad8406

Fig. 358 Install Valve Body To Transaxle

- 1 - VALVE BODY

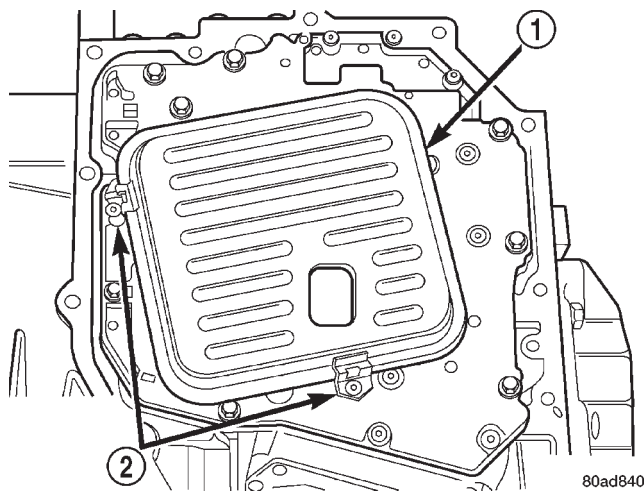

80ad8404

Fig. 360 Install Transaxle Oil Filter

- 1 - TRANSAXLE FILTER
- 2 - FILTER RETAINING CLIPS

DISASSEMBLY AND ASSEMBLY (Continued)

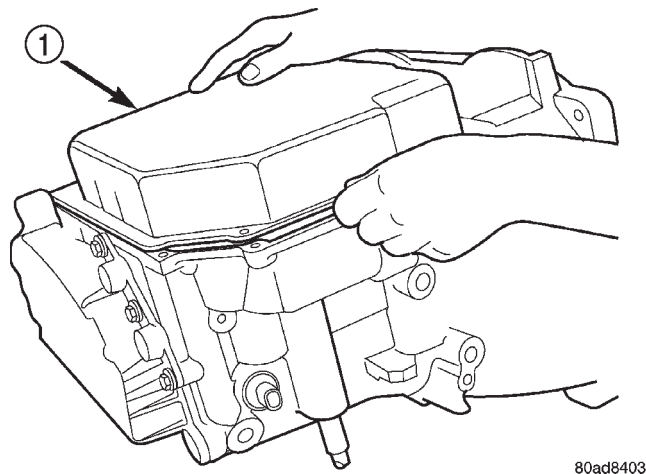

80ad8403

Fig. 361 Install Transaxle Oil Pan

1 - TRANSAXLE OIL PAN

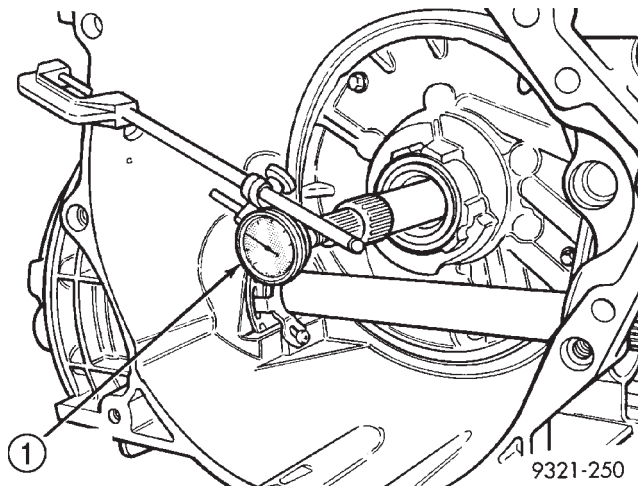

9321-250

Fig. 363 Measure Input Shaft End Play

1 - DIAL INDICATOR

Install both speed sensors from transaxle case (Fig. 362).

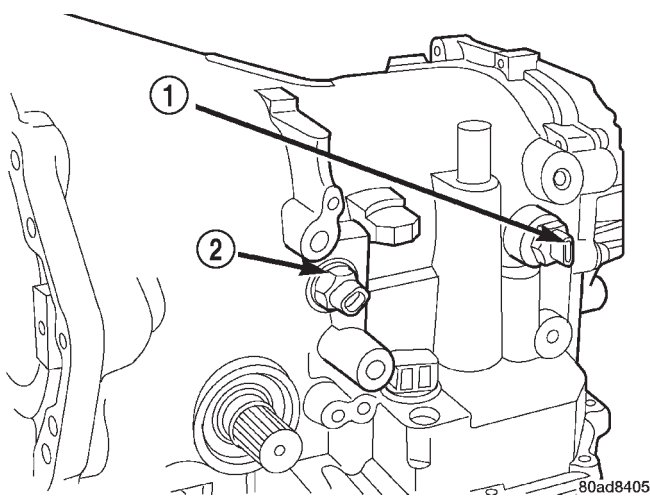

80ad8405

Fig. 362 Install Input and Output Speed Sensor

1 - OUTPUT SPEED SENSOR
2 - INPUT SPEED SENSOR

As a final check of the transaxle, measure the input shaft end play. This will indicate when a #4 thrust plate change is required. The number 4 thrust plate is located behind the overdrive clutch hub. Attach a dial indicator to transaxle bell housing with its plunger seated against end of input shaft (Fig. 363). Move input shaft in and out to obtain end play reading. End play specifications are .13 to .64 mm (.005 to .025 inch). If not within specifications, make the necessary thrust plate adjustment.

DIFFERENTIAL RECONDITION

The valve body and solenoid wiring connector must be removed from the transaxle in order to recondition the transaxle differential. The transfer shaft cannot

be removed with the valve body in place. Refer to Valve Body Recondition for removal procedure.

If any bearings in the differential require replacement, all the bearings on the differential carrier and transfer shaft must be replaced. The differential adjusters must also be replaced when differential bearings are replaced.

DISASSEMBLY

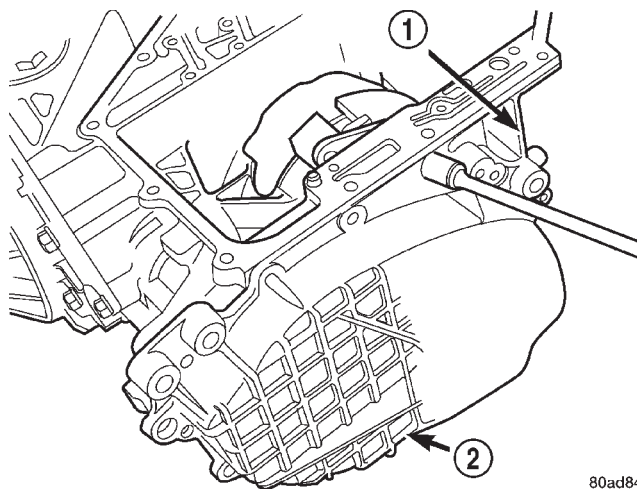

80ad8407

Fig. 364 Remove Chain Cover

1 - TRANSAXLE CASE
2 - CHAIN COVER

CAUTION: The chain sprockets have a slip fit onto their shafts. Apply only a slight amount of pressure to the chain spreader to release the chain pressure. If chain sprockets are not spread slightly removal or installation will be difficult. Overspreading of the chain sprocket will also make sprocket removal difficult.

DISASSEMBLY AND ASSEMBLY (Continued)

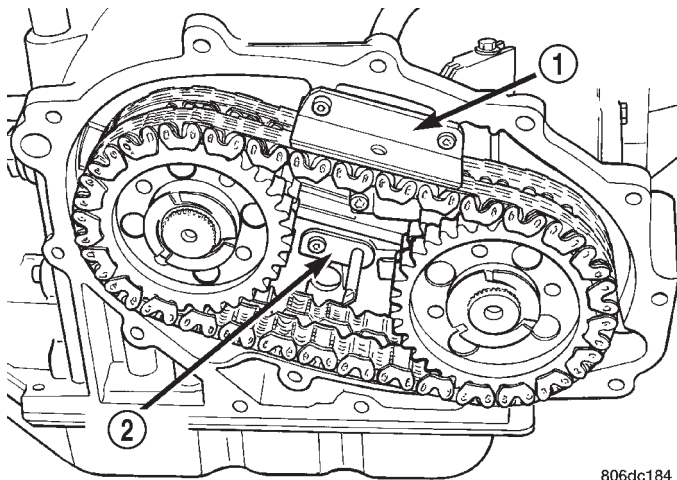

806dc184

Fig. 365 Remove Chain Oiler

- 1 - CHAIN SNUBBER
- 2 - CHAIN OILER

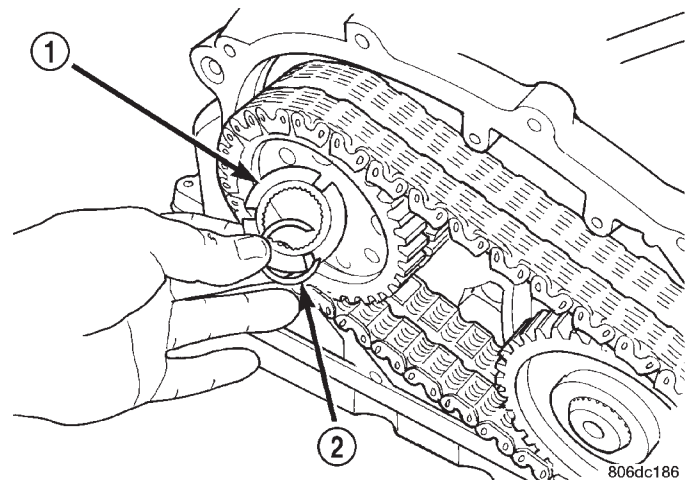

806dc186

Fig. 367 Remove Output Shaft Sprocket Snap Ring and Wave Washer

- 1 - WAVE WASHER
- 2 - SNAP RING

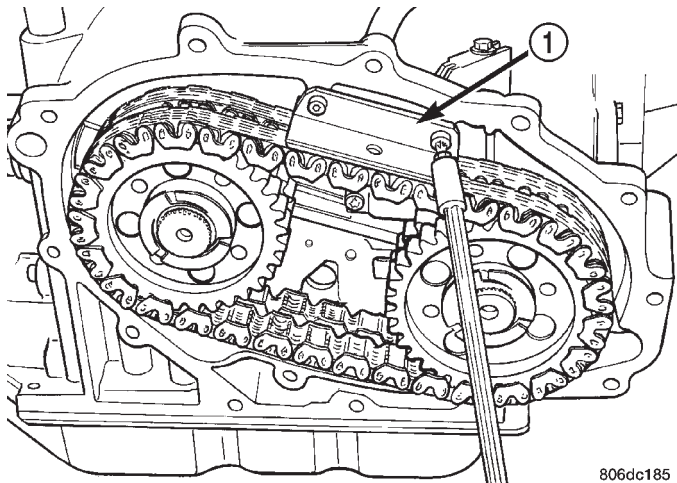

806dc185

Fig. 366 Remove Chain Snubber

- 1 - CHAIN SNUBBER

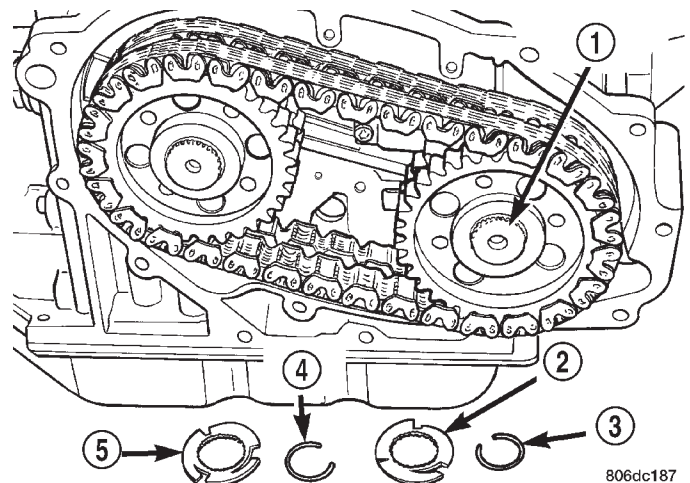

806dc187

Fig. 368 Remove Transfer Shaft Sprocket Snap Ring and Wave Washer

- 1 - TRANSFER SHAFT
- 2 - WAVE WASHER
- 3 - SNAP RING
- 4 - SNAP RING
- 5 - WAVE WASHER

CAUTION: To ensure proper gear ratio, verify that the correct chain and sprocket ratio is selected.

CAUTION: When reinstalling drive chains, the blue link must face outward.

DISASSEMBLY AND ASSEMBLY (Continued)

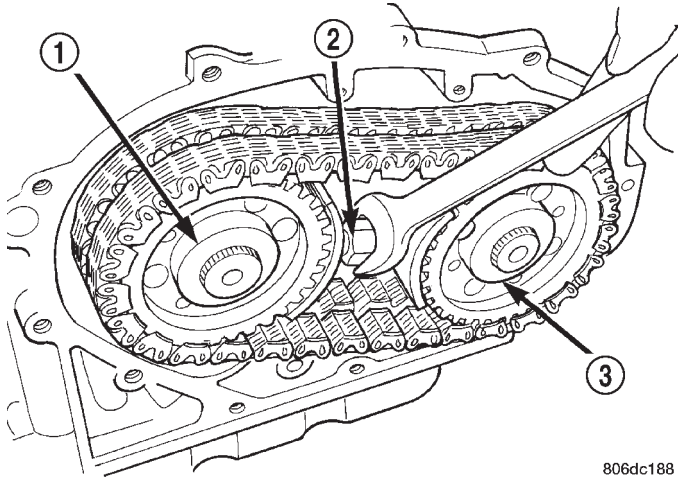

Fig. 369 Install Chain Spreader

- 1 - OUTPUT SPROCKET
- 2 - SPECIAL TOOL 6550
- 3 - TRANSFER SPROCKET

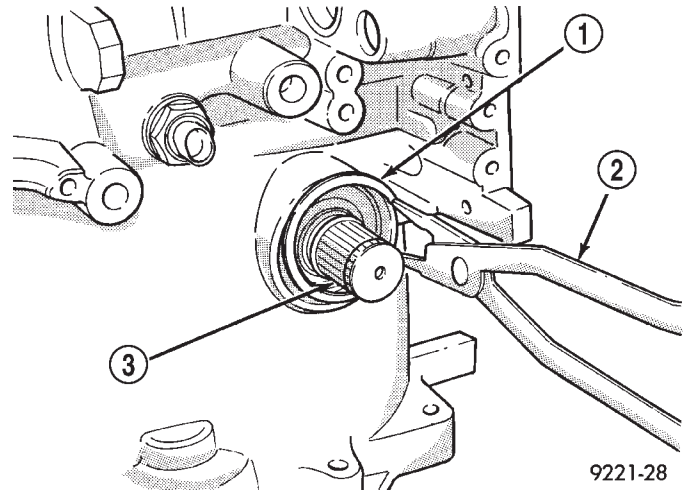

Fig. 371 Remove Long Stub Shaft Snap Ring

- 1 - SNAP RING
- 2 - SNAP RING PLIERS
- 3 - LONG STUB SHAFT

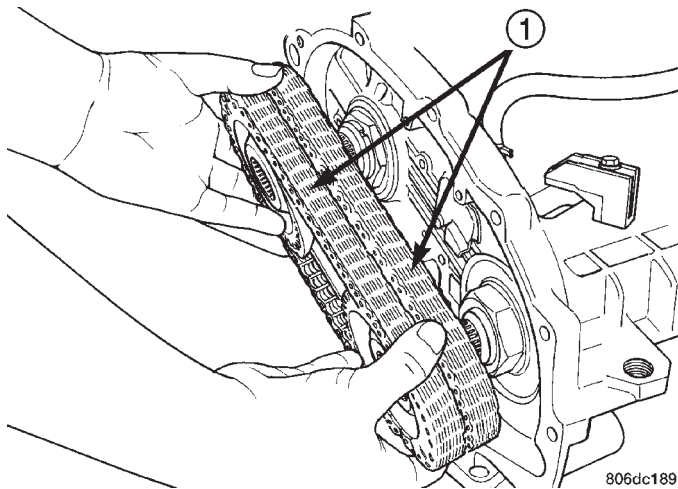

Fig. 370 Remove Chains and Sprockets as an Assembly

- 1 - CHAINS

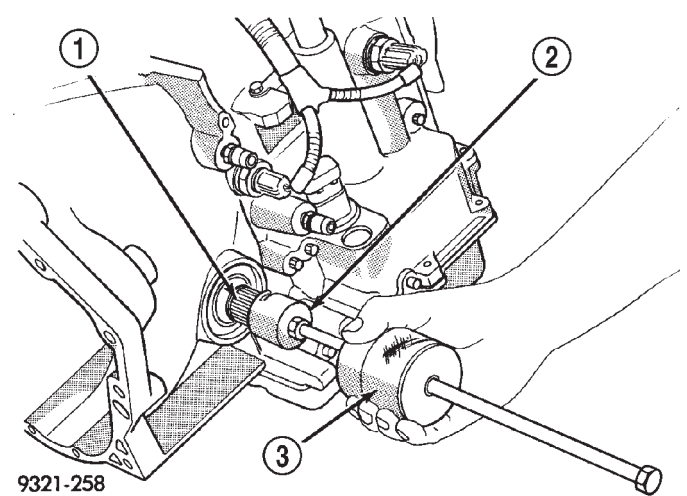

Fig. 372 Remove Long Stub Shaft

- 1 - LONG STUB SHAFT
- 2 - SPECIAL TOOL 6669
- 3 - SLIDE HAMMER C-3752

CAUTION: Driveshaft retainer clips and seals located on the stub shafts must be replaced before reinstalling driveshafts.

DISASSEMBLY AND ASSEMBLY (Continued)

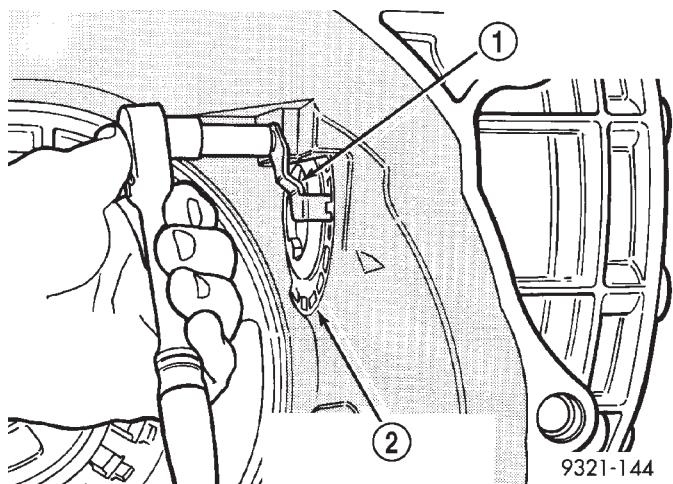

Fig. 373 Remove Inner Differential Adjuster Lock

- 1 - INNER DIFFERENTIAL ADJUSTER LOCK
- 2 - INNER DIFFERENTIAL ADJUSTER

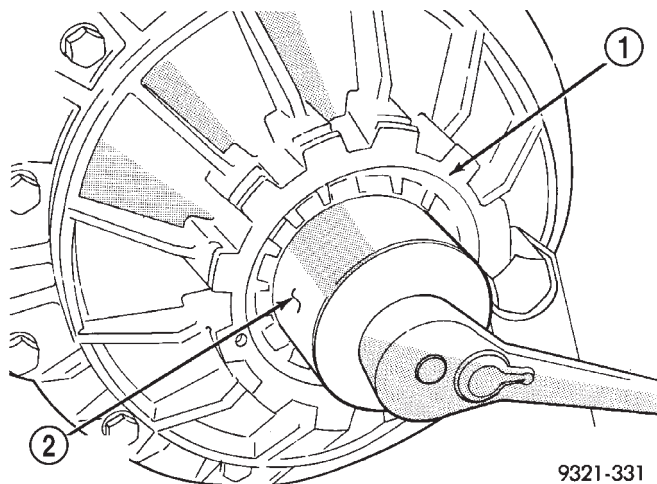

Fig. 375 Loosen Outer Adjuster

- 1 - OUTER ADJUSTER
- 2 - SPECIAL TOOL 6503

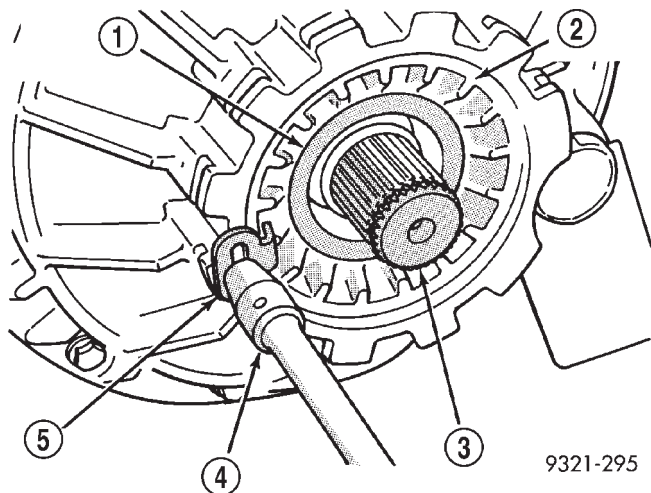

Fig. 374 Remove Outer Adjuster

- 1 - OIL SEAL
- 2 - OUTER ADJUSTER
- 3 - STUB SHAFT
- 4 - SOCKET
- 5 - ADJUSTER LOCK

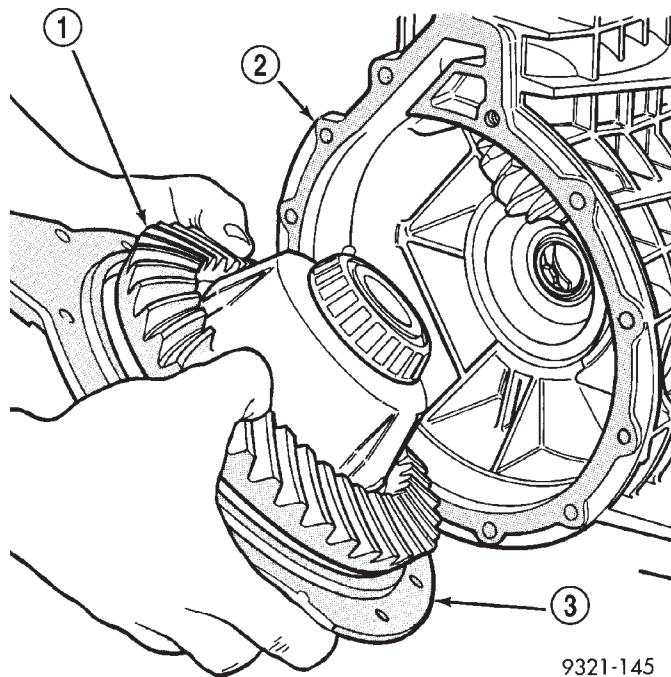

Fig. 376 Remove Differential Side Cover, Carrier and Ring Gear Assembly

- 1 - RING GEAR
- 2 - TRANSAXLE CASE
- 3 - SIDE COVER

If the carrier requires reconditioning, refer to Differential Carrier Recondition.

CAUTION: Failure to grind and open stakes on the transfer shaft nut will result in thread damage to transfer shaft during nut removal.

DISASSEMBLY AND ASSEMBLY (Continued)

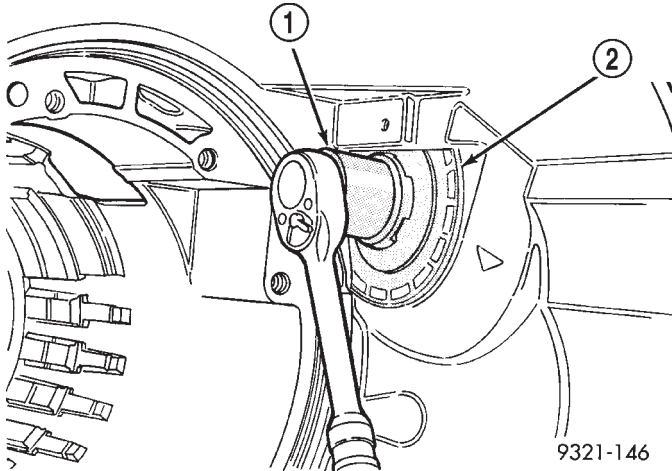

Fig. 377 Remove Inner Adjuster By Turning Clockwise

- 1 - SPECIAL TOOL 6502-B
- 2 - INNER DIFFERENTIAL ADJUSTER

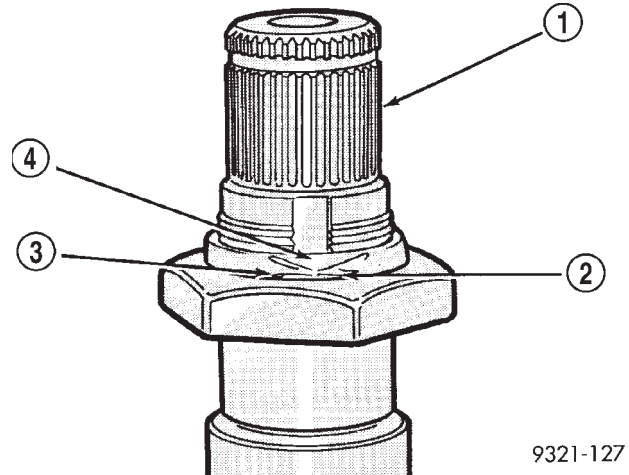

Fig. 379 Grinding Stakes

- 1 - TRANSFER SHAFT
- 2 - GRIND HERE
- 3 - GRIND HERE
- 4 - NUT STAKE

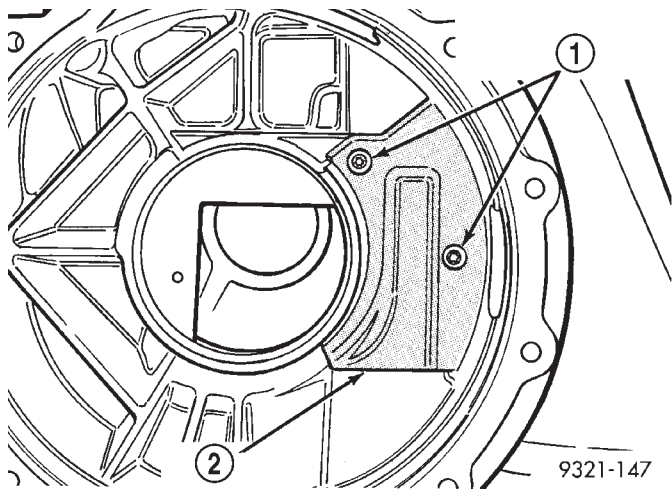

Fig. 378 Remove Differential Vent Baffle

- 1 - VENT BAFFLE RETAINING SCREWS
- 2 - VENT BAFFLE

WARNING: WEAR SAFETY GOGGLES WHILE GRINDING STAKE NUTS.

Using a die grinder or equivalent, grind the stakes in the shoulder of the shaft nut as shown in (Fig. 379) and (Fig. 380). Do not grind through the transfer shaft nut into the shaft. There are two stakes on the nut.

Using a small chisel, carefully open stakes on nut (Fig. 381)

Remove the transfer shaft nut.

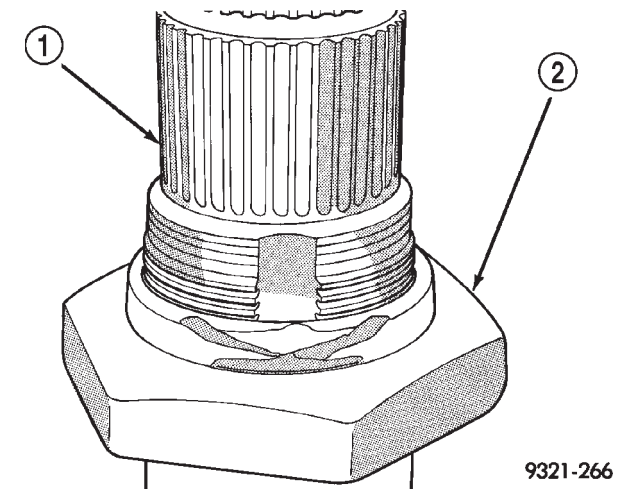

Fig. 380 Stake Grinding Pattern

- 1 - TRANSFER SHAFT
- 2 - TRANSFER SHAFT NUT

CAUTION: Do not reuse old transfer shaft nut because the removed stake weakens the nut flange.

CAUTION: The transfer shaft cannot be removed from the case at this time.

Install special tool 6577 to remove rear transfer bearing cup (Fig. 383).

DISASSEMBLY AND ASSEMBLY (Continued)

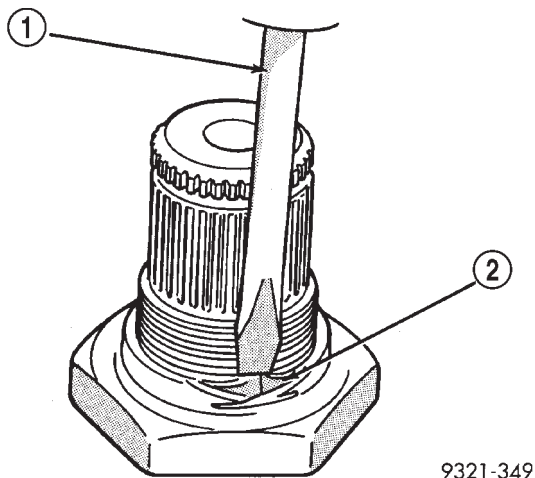

Fig. 381 Opening Nut Stakes

- 1 - CHISEL
- 2 - NUT STAKE

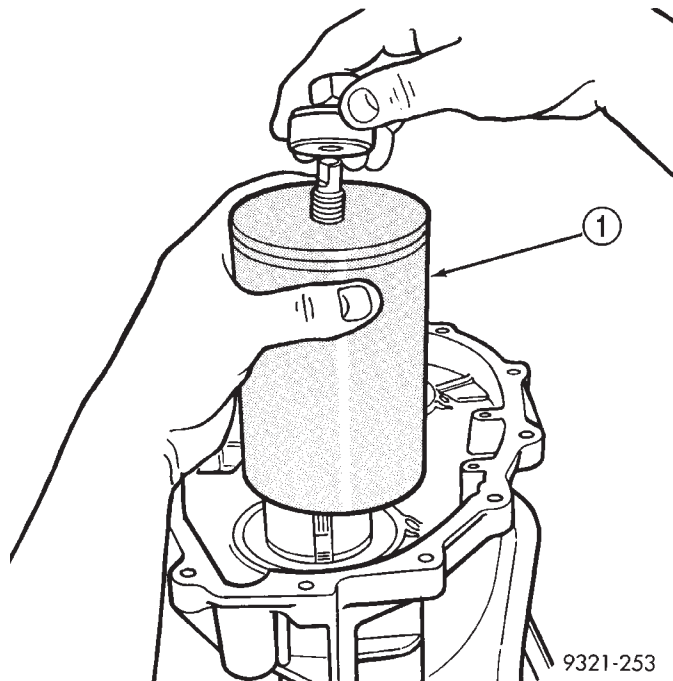

Fig. 383 Transfer Bearing Cup Removal

- 1 - SPECIAL TOOL 6577

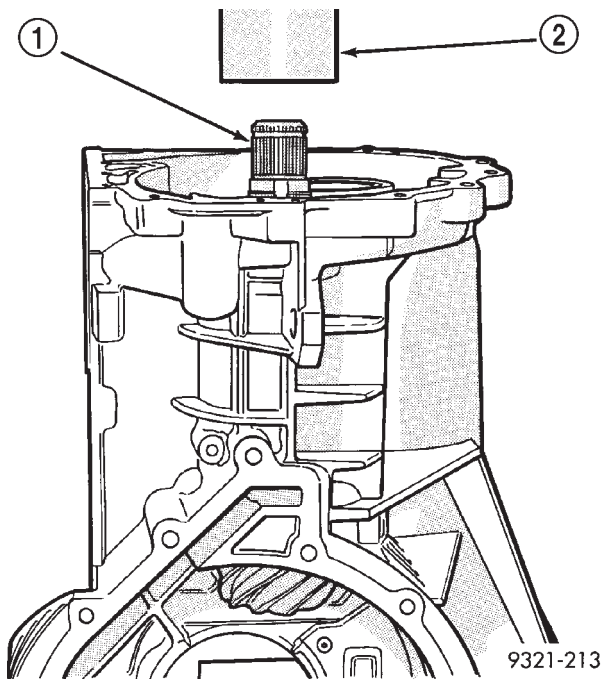

Fig. 382 Press Transfer Shaft Downward to Remove Rear Cone

- 1 - TRANSFER SHAFT
- 2 - ARBOR PRESS

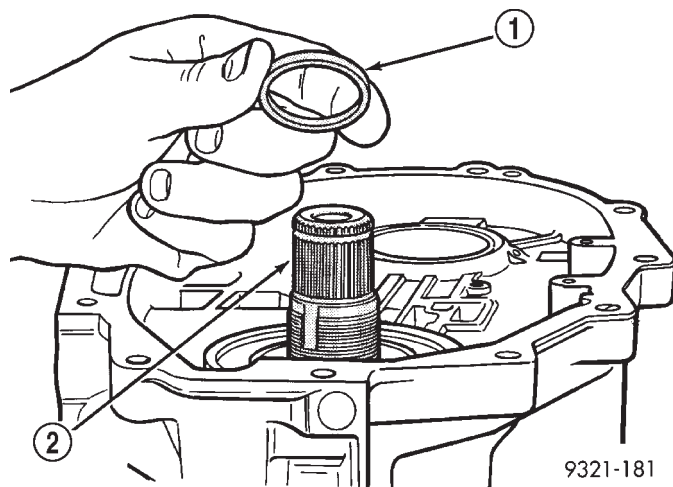

Fig. 384 Preload Shim Removal

- 1 - TRANSFER SHAFT PRELOAD SHIM
- 2 - TRANSFER SHAFT

Remove transfer shaft preload shim (Fig. 384). If transfer shaft bearings are to be reused, the original shim must also be reused.

CAUTION: If the transfer shaft is removed from the transaxle case for any reason, both seals must be replaced.

Remove transfer shaft seals (Fig. 386) using special tool 6310 and foot 6310-9 (Tar 960). Do not reuse old seals. The seals will be pulled out the rear of the case.

Remove the front transfer shaft bearing cup using special tool 6495 and handle C-4171 (Fig. 387). Use a press with special tools to remove cup.

DISASSEMBLY AND ASSEMBLY (Continued)

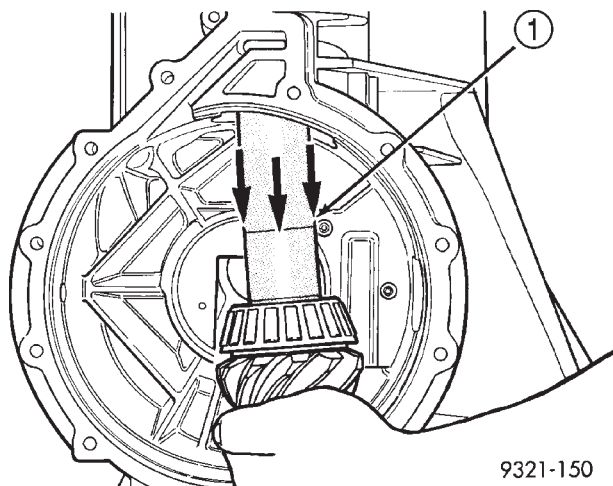

9321-150
Fig. 385 Remove Transfer Shaft Assembly From Case

1 - TRANSFER SHAFT

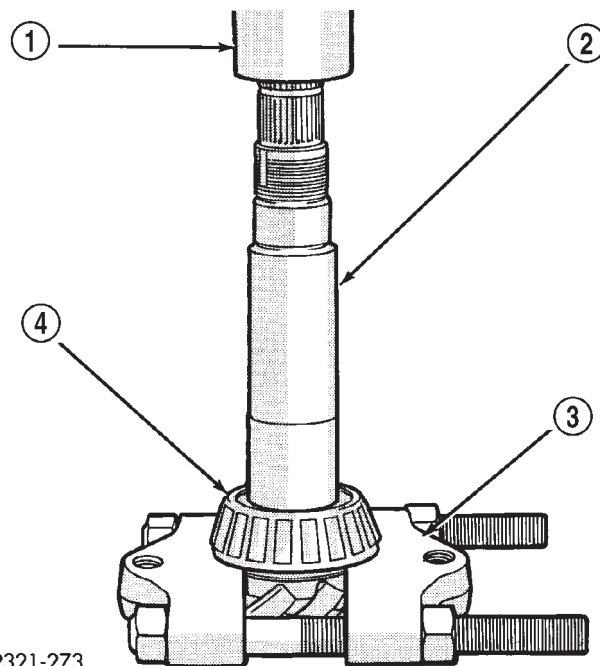

9321-273
Fig. 388 Remove Front Transfer Shaft Bearing And Pinion Depth Shim

1 - ARBOR PRESS
2 - TRANSFER SHAFT
3 - SPECIAL TOOL P-334
4 - FRONT TRANSFER SHAFT BEARING

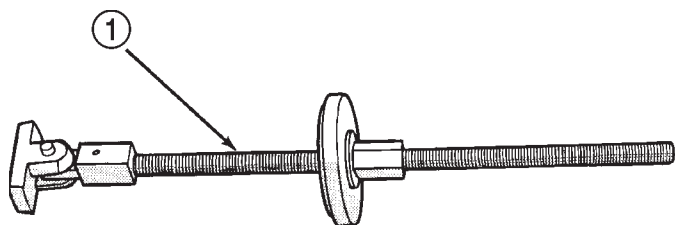

9321-252
Fig. 386 Transfer Shaft Seal Remover

1 - SPECIAL TOOL 6310

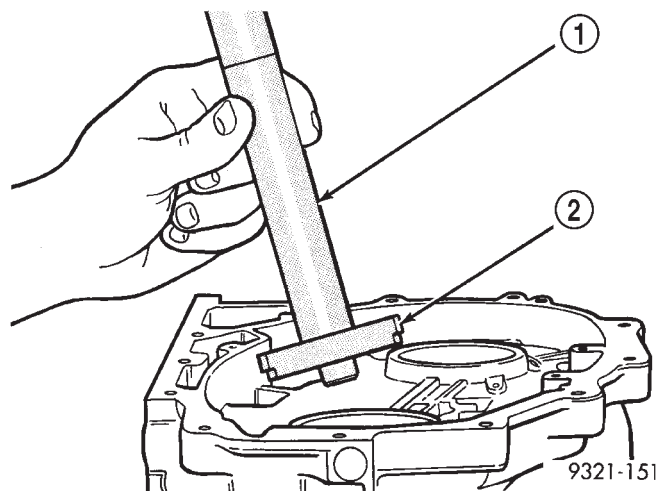

9321-151
Fig. 387 Front Transfer Shaft Cup Removal

1 - SPECIAL TOOL C-4171
2 - SPECIAL TOOL 6495

Support special tool P-334 on press table so that pinion head of transfer shaft can be pressed through table (Fig. 388).

ASSEMBLE AND BEARING ADJUSTMENT PROCEDURE

The following steps will determine the correct shim thickness required to obtain proper pinion depth. All special tools described in this procedure must be used to obtain correct results.

CAUTION: Failure to adjust pinion depth correctly could cause gear noise or transaxle failure.

(1) Install front transfer shaft bearing cup (Fig. 389). The transfer shaft bearing cup must be installed before making pinion depth measurement. Use special tool 6494 to install bearing cup. There are no shims located behind this bearing cup.

CAUTION: The bearing cup is seated in the case correctly if there is no clearance between the bottom of the bearing cup and case. If a 0.001" or 0.002" feeler gauge does not fit, the bearing cup is completely seated into transaxle case.

(2) Install centering block (special tool 6549-2) into the transaxle case (Fig. 390). Screw centering block into inner adjuster hole of case until it bottoms. The pegs on the special tool are only used for installation. Orientation with in the case is not required.

DISASSEMBLY AND ASSEMBLY (Continued)

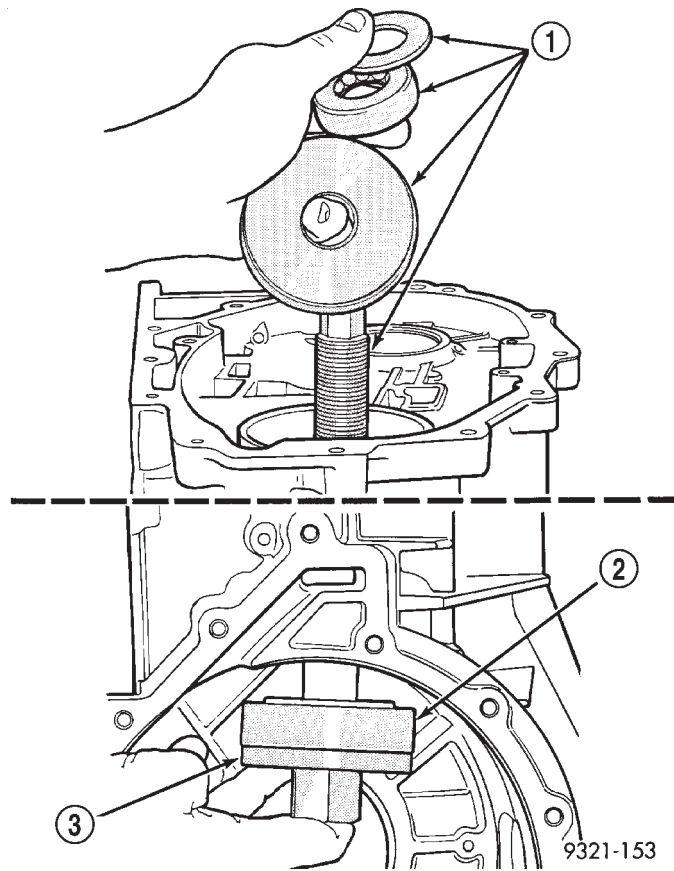

Fig. 389 Install Front Transfer Shaft Cup

- 1 - SPECIAL TOOL 6494
- 2 - BEARING CUP
- 3 - SPECIAL TOOL 6494

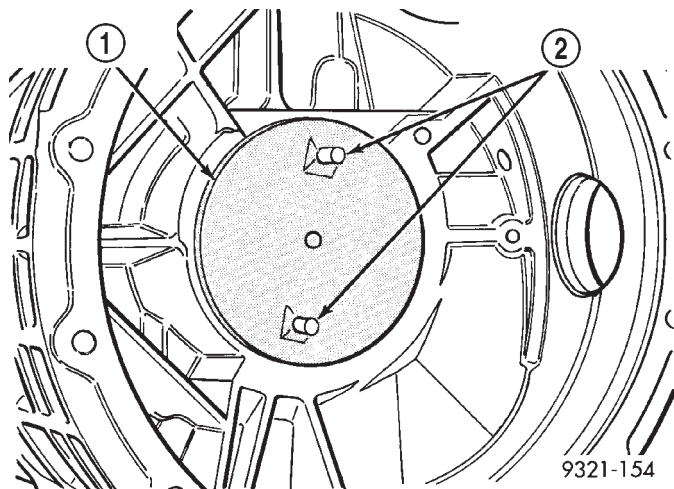

Fig. 390 Installing Centering Block

- 1 - SPECIAL TOOL 6549-2
- 2 - TOOL INSTALLATION AND REMOVAL PEGS

(3) Install new front bearing (actual bearing to be used during reassembly) onto gauge disc (special tool 6549-3) (Fig. 391).

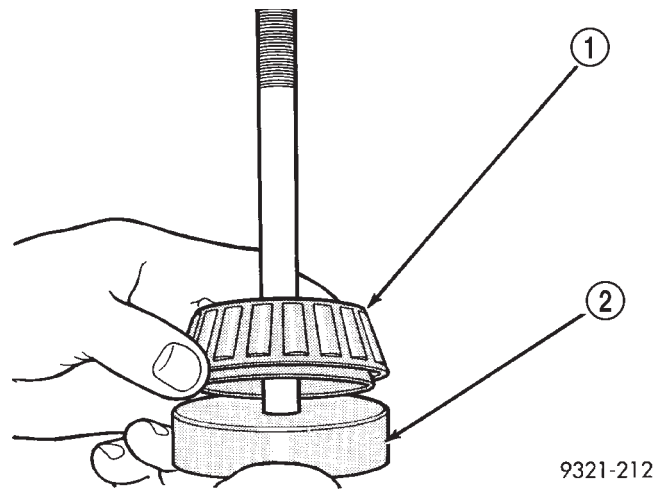

Fig. 391 Gauge Disc and Bearing

- 1 - FRONT TRANSFER SHAFT BEARING
- 2 - SPECIAL TOOL 6549-3

(4) Install gauge disc and bearing into case using gauge disc rod Tool 6549-4 (Fig. 392).

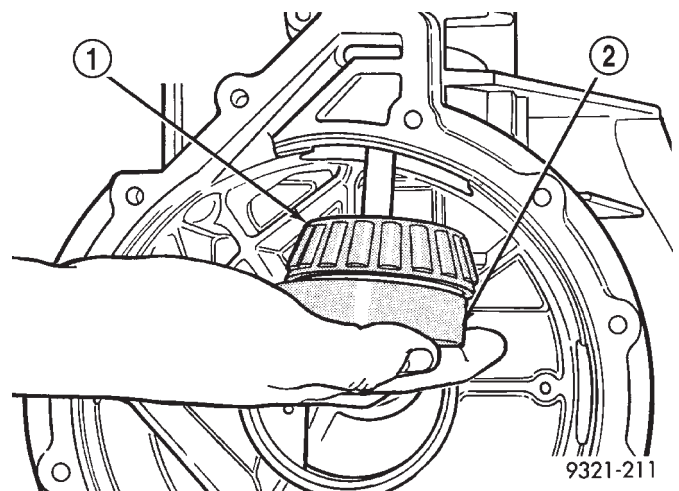

Fig. 392 Installing Gauge Disc with Front Transfer Shaft Bearing

- 1 - FRONT TRANSFER SHAFT BEARING
- 2 - SPECIAL TOOL 6549-3

(5) Install centering disc (special tool 6494-2) onto gauge disc rod (Fig. 393).

(6) Install centering nut Tool 6549-5 as shown in (Fig. 394).

(7) Hand tighten centering nut until all play in the tool has been removed.

DISASSEMBLY AND ASSEMBLY (Continued)

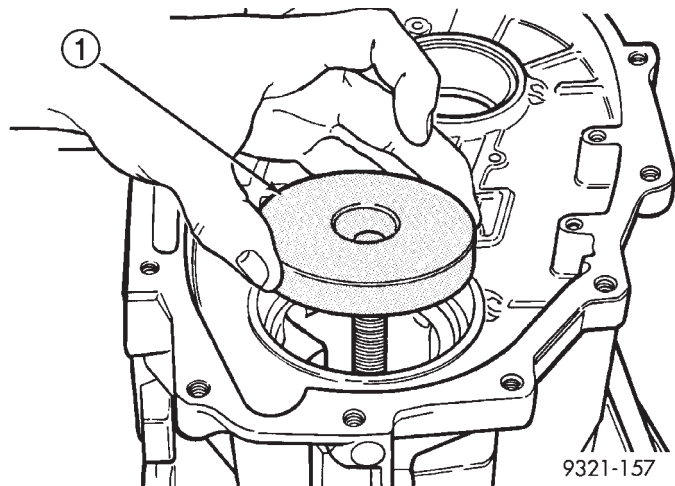

Fig. 393 Disc Installation

- 1 - SPECIAL TOOL 6494-2

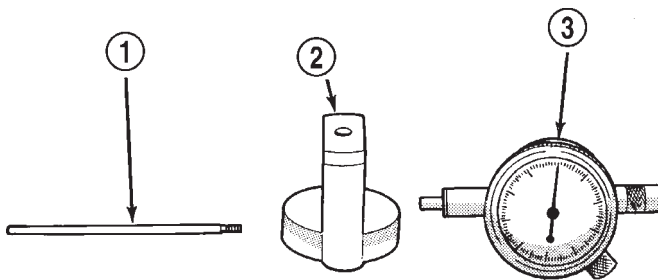

Fig. 395 Dial indicator, Locating Block and Extension Rod

- 1 - EXTENSION ROD SPECIAL TOOL
- 2 - LOCATING BLOCK SPECIAL TOOL
- 3 - DIAL INDICATOR

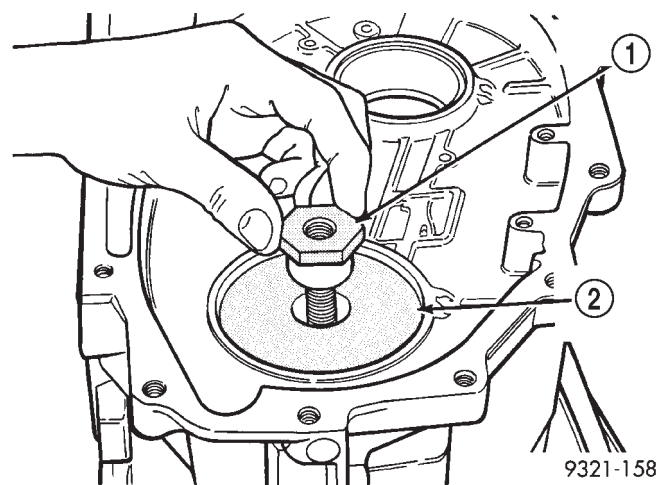

Fig. 394 Installing Centering Nut

- 1 - CENTERING NUT
- 2 - CENTERING DISC (6494-2)

(8) Install dial indicator into locating block Tool 6549-1. Then screw extension rod onto dial indicator.

NOTE: The dial indicator used to make this measurement must have a face that shows 0-50-0 (Special Tool C-3339) readings (Fig. 396). All steps from this point forward will reflect this assumption. This will give you proper shim thickness.

(9) Before making a pinion depth measurement the dial indicator must be zeroed. This is done by placing the dial indicator in the zeroing fixture (special tool 6549-6). Then place the zeroing fixture on a flat surface. Adjust the dial face so the pointer on the dial indicator lines up with the zero (Fig. 397).

(10) Compress the dial indicator slightly and insert dial indicator pin into centering block (Fig. 398).

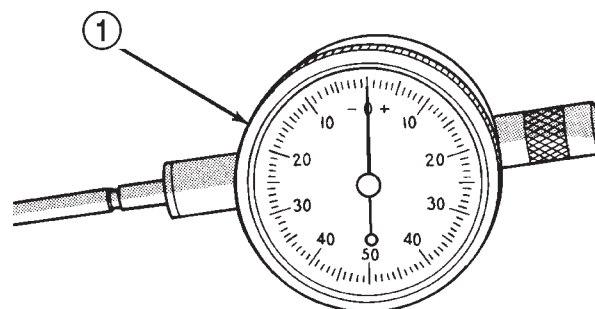

Fig. 396 0-50-0 Dial Indicator

- 1 - DIAL INDICATOR

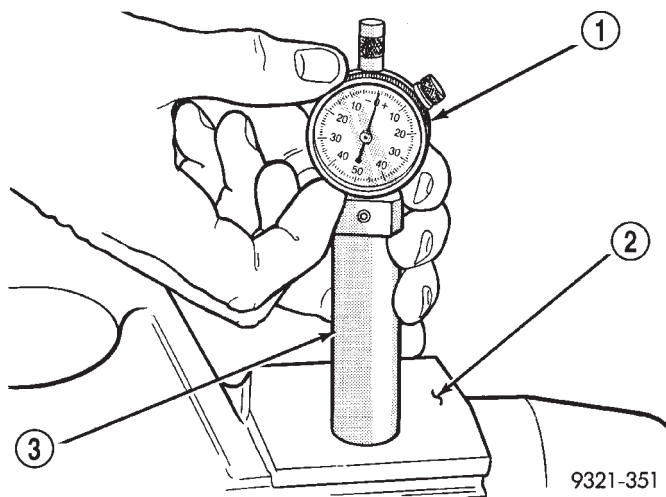
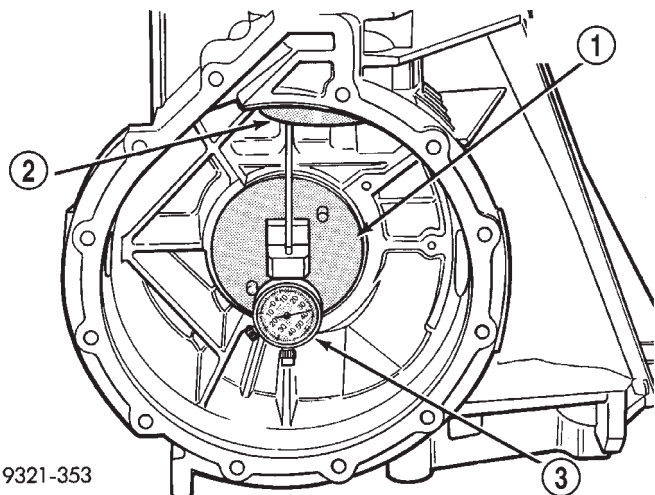

Fig. 397 Zero Dial Indicator

- 1 - DIAL INDICATOR
- 2 - FLAT SURFACE
- 3 - ZEROING FIXTURE

(11) Pivot dial indicator back and forth (Fig. 399) on centering pin to obtain the shortest distance measurement. **This will be the lowest number read-**

DISASSEMBLY AND ASSEMBLY (Continued)



9321-353

Fig. 398 Mounting Dial Indicator to Centering Block

- 1 - CENTERING BLOCK
- 2 - GAUGE DISC
- 3 - DIAL INDICATOR

ing on dial indicator. Record the number obtained. Now rotate the gauge disc clockwise 1/3 of a turn and recheck readings. Record number obtained. Rotate the gauge disc another 1/3 of a turn clockwise and take another reading. Average the three readings. Record this pinion depth measurement. If the readings differ by more than two thousandths recheck gauge disc installation, it may have been installed slightly cocked.

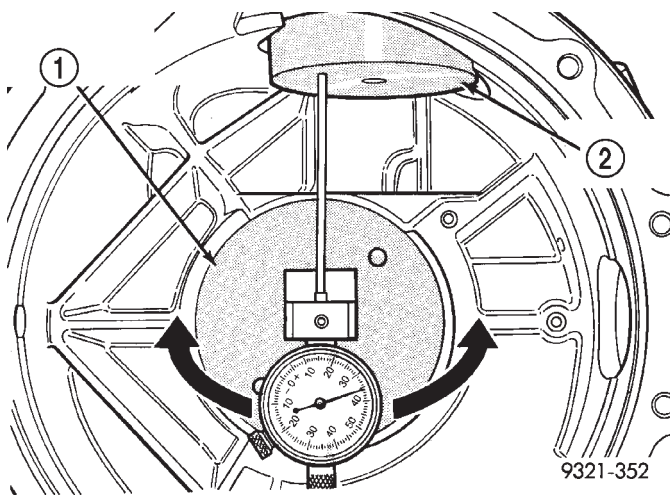

9321-352

Fig. 399 Pivot Dial Indicator

- 1 - CENTERING BLOCK
- 2 - GAUGE DISC

(12) To determine the required shim thickness, the pinion depth measurement must be adjusted. The pinion shim adjustment number is the first of seven digits ink stamped on the shank of the transfer shaft (Fig. 400). Using the adjustment factor chart

the adjustment number to the corresponding adjustment factor. Utilizing the pinion depth measurement obtained in Step 11, add or subtract the adjustment factor to calculate the required shim thickness. Refer to pinion head shim chart for shim selections. This is the shim that will be installed between the transfer shaft pinion head and the front transfer shaft bearing. Refer to the following examples for further explanation:

(13) Example 1 in (MM):

- Measured pinion shim depth: 0.789mm
- Adjustment number on transfer shaft: +2
- Adjustment factor (mm): -0.051mm
- Shim size needed: $0.789 - 0.051 = \mathbf{0.738mm}$

(14) Example 2 in (IN):

- Measured pinion shim depth: 0.032in
- Adjustment number on transfer shaft: -1
- Adjustment factor (in): +0.001
- Shim size needed: $0.032 + 0.001 = \mathbf{0.033in}$

ADJUSTMENT NUMBER	ADJUSTMENT FACTOR mm	ADJUSTMENT FACTOR in
3	-0.076	-0.003
2	-0.051	-0.002
1	-0.025	-0.001
0	0.000	0.000
-1	0.025	0.001
-2	0.051	0.002
-3	0.076	0.003

9421-72

ADJUSTMENT FACTOR CHART

(15) Remove dial indicator, gauge disc and centering block from transaxle.

(16) Install shim selected in Step 12 of this procedure onto the transfer shaft (Fig. 400).

(17) Press front transfer shaft bearing onto transfer shaft (special tool 6052). The shim must be in place before pressing on bearing (Fig. 401).

(18) At this point the pinion depth has been determined and the shim has been installed onto the transfer shaft. Before the pinion is installed into the transaxle case, bearing preload must be determined for the differential bearings. The following steps must be performed before the pinion is installed.

(19) The following steps will determine how many foot pounds are required on the outer differential adjuster to obtain the correct turning torque.

CAUTION: Failure to set differential bearing preload correctly may cause bearing failure, gear noise and/or axle shaft seal failure.

DISASSEMBLY AND ASSEMBLY (Continued)

SHIM THICKNESS	
MM	INCH
0.681 - 0.707	0.0265 - 0.0275
0.708 - 0.734	0.0276 - 0.0286
0.735 - 0.761	0.0286 - 0.0296
0.762 - 0.788	0.0297 - 0.0307
0.789 - 0.815	0.0307 - 0.0317
0.816 - 0.842	0.0318 - 0.0328
0.843 - 0.869	0.0328 - 0.0338
0.871 - 0.896	0.0339 - 0.0349
0.897 - 0.923	0.0349 - 0.0359
0.924 - 0.951	0.0360 - 0.0370
0.951 - 0.977	0.0370 - 0.0381
0.978 - 1.004	0.0381 - 0.0391
1.005 - 1.031	0.0391 - 0.0402
1.032 - 1.058	0.0402 - 0.0412
1.059 - 1.085	0.0413 - 0.0423
1.086 - 1.112	0.0423 - 0.0433
1.113 - 1.139	0.0434 - 0.0444

9421-67

PINION HEAD SHIM CHART

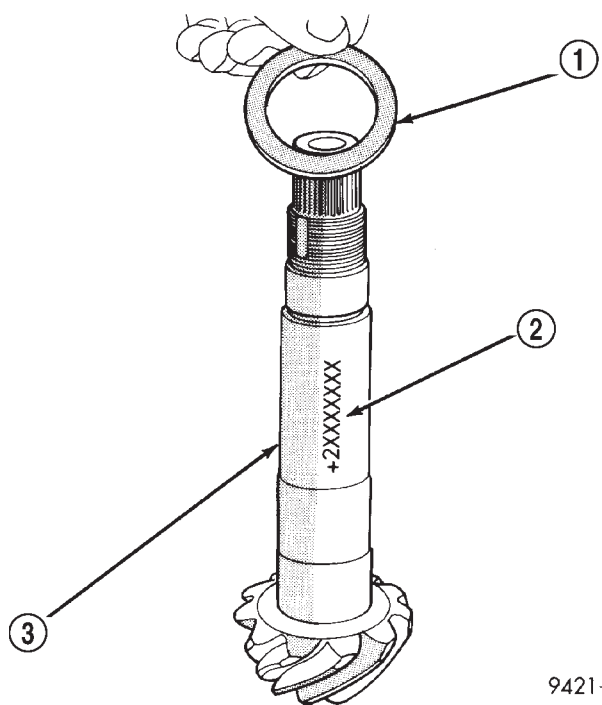

9421-66

Fig. 400 Shim Installation

- 1 - PINION DEPTH SHIM
- 2 - ADJUSTMENT FACTOR
- 3 - TRANSFER SHAFT

(20) Remove outer adjuster with special tool 6503 (Fig. 402).

(21) Remove old stub shaft seals. Press inner adjuster seal out with special tool 6502B. Press outer adjuster seal out with special tool 6558.

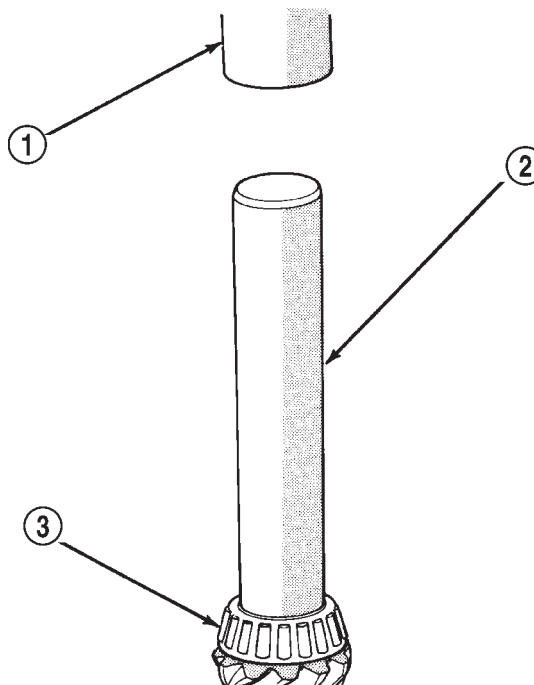

9421-65

Fig. 401 Bearing Installation

- 1 - ARBOR PRESS
- 2 - SPECIAL TOOL 6052
- 3 - FRONT TRANSFER SHAFT BEARING

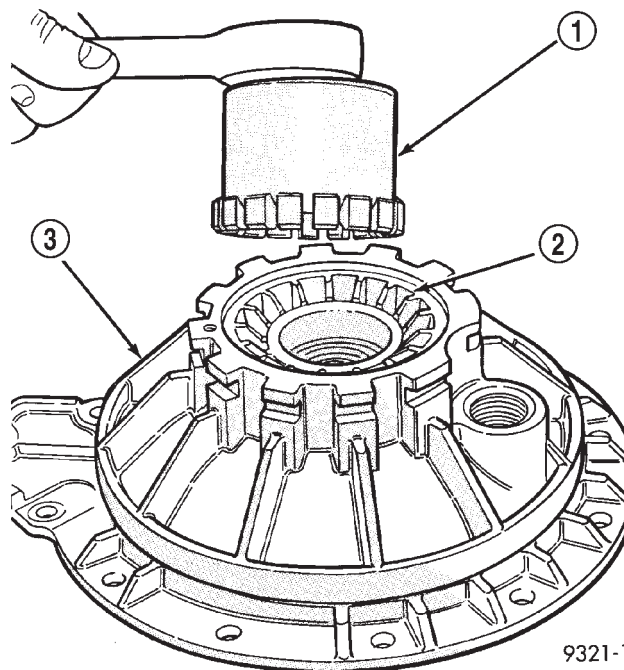

9321-165

Fig. 402 Outer Adjuster Removal

- 1 - SPECIAL TOOL 6503
- 2 - OUTER DIFFERENTIAL ADJUSTER
- 3 - SIDE COVER

(22) Install new stub shaft seals in both adjusters using special tool 6558 (Fig. 403).

DISASSEMBLY AND ASSEMBLY (Continued)

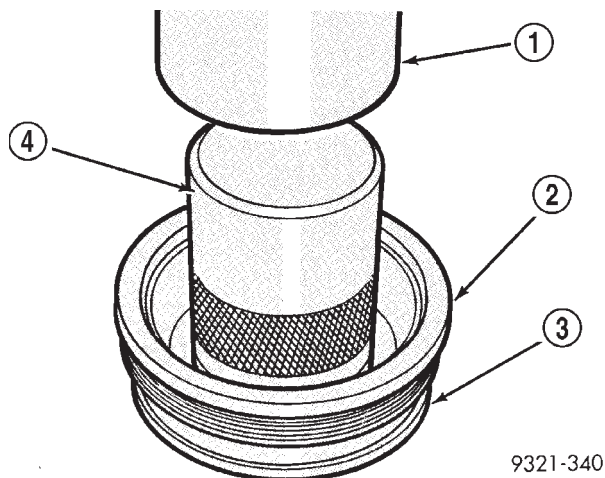

Fig. 403 Axle Shaft Seal Installation

- 1 - ARBOR PRESS
- 2 - OUTER DIFFERENTIAL ADJUSTER
- 3 - O-RING
- 4 - SPECIAL TOOL 6558

NOTE: To remove inner and outer adjuster races, use Tool 6062-A. To install inner and outer adjuster races, use Tool 6522 and Tool C-4171.

(23) Lube adjuster threads and O-ring with gear oil before installing. Failure to lube threads will result in thread damage to the adjuster and transaxle case.

(24) Screw in the inner adjuster using special tool 6502B (Fig. 404). The inner adjuster should be screwed in until under-flush with inside of the case (viewed from differential side).

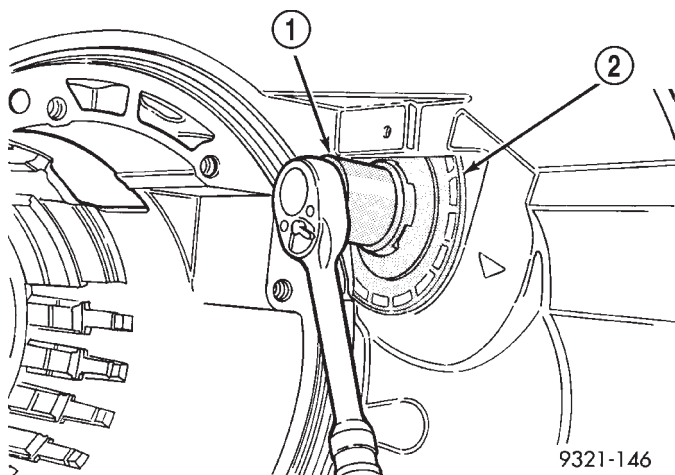

Fig. 404 Inner Adjuster Installation

- 1 - SPECIAL TOOL 6502-B
- 2 - INNER DIFFERENTIAL ADJUSTER

(25) Install differential assembly into the transaxle case (Fig. 405).

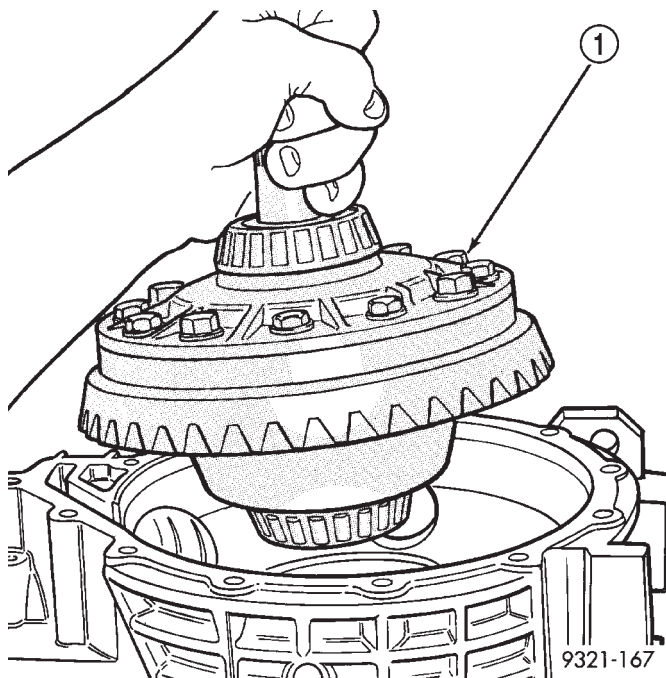

Fig. 405 Differential Assembly Installation

- 1 - DIFFERENTIAL ASSEMBLY

(26) Install differential cover (Fig. 406). Do not apply silicone sealant at this time. All bolts should be installed and tightened.

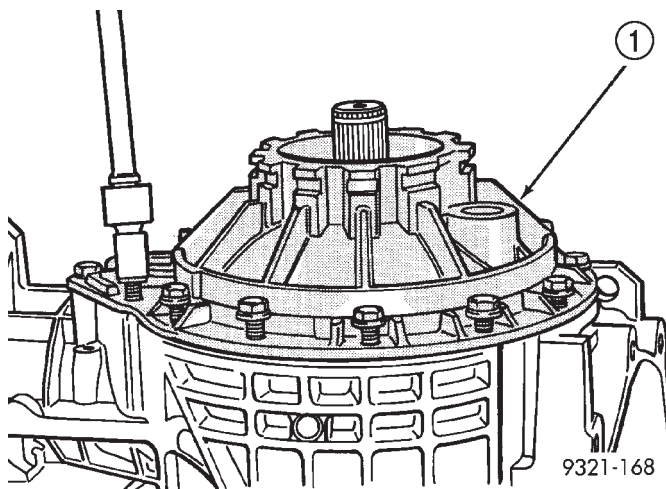

Fig. 406 Differential Cover Installation

- 1 - SIDE COVER

(27) Install seal protector (special tool 6591) as shown in (Fig. 407). Apply a thin film of gear oil on the protector.

CAUTION: Lube threads and O-ring on adjuster before installing. Failure to do so will result in thread damage to the adjuster and transaxle case.

DISASSEMBLY AND ASSEMBLY (Continued)

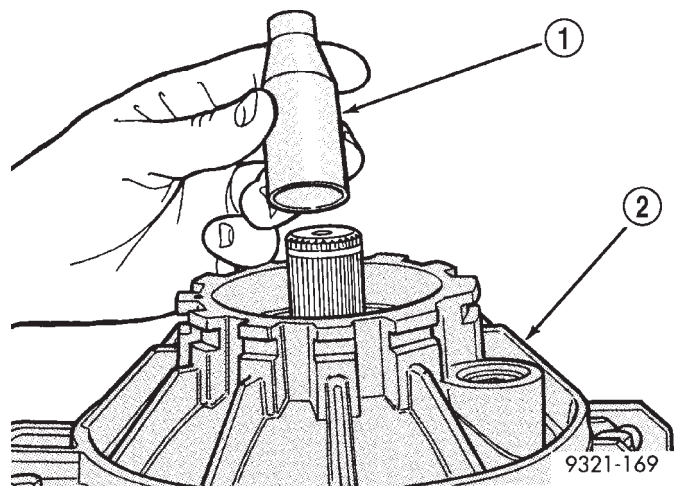

Fig. 407 Seal Protector

- 1 - SEAL PROTECTOR (6591)
- 2 - SIDE COVER

(28) Screw on outer adjuster and tighten adjuster down finger tight (Fig. 408).

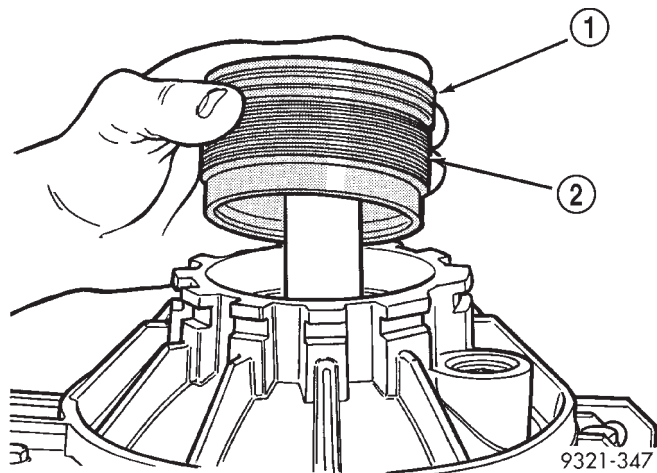

Fig. 408 Outer Adjuster Installation

- 1 - O-RING
- 2 - OUTER ADJUSTER

(29) Insert special tool 6548 (Fig. 409). This tool will be used to check turning torque of the differential assembly.

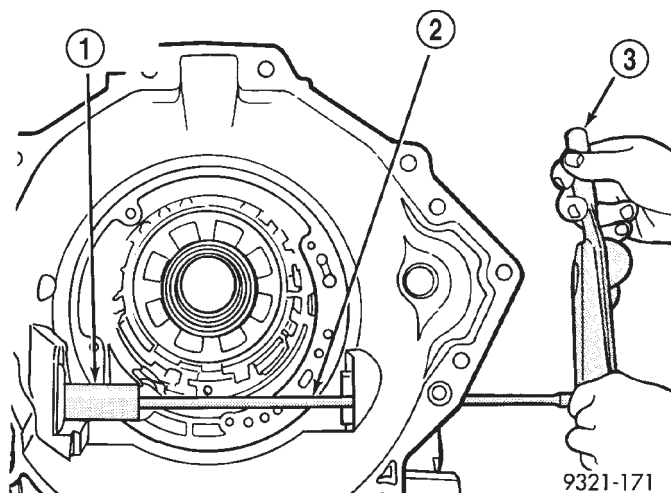

Fig. 409 Special Tool 6548

- 1 - SPECIAL TOOL 6548
- 2 - 1/4" EXTENSION
- 3 - TORQUE WRENCH

CAUTION: Differential bearings must be seated before taking turning torque readings. This is done by rotating the differential three or four turns in both directions.

CAUTION: Turning torque of 19 to 23 in. lbs. can only be obtained when using new bearings. Do not attempt to obtain this turning torque with used bearings.

(30) Tighten outer adjuster with tool 6503 until 19 to 23 in. lbs. of turning torque is obtained on tool 6548. **Record how many foot pounds were required on the outer adjuster to obtain the correct turning torque** (Fig. 410). Record the foot pound reading. The reading that you are recording will be used in Step 55 of this procedure.

(31) Remove the differential cover, differential carrier assembly and inner adjuster.

(32) At this point the amount of torque required on the outer differential adjuster has been determined. The transfer shaft can now be installed into the transaxle case. Perform the following steps to install transfer shaft into transaxle case.

DISASSEMBLY AND ASSEMBLY (Continued)

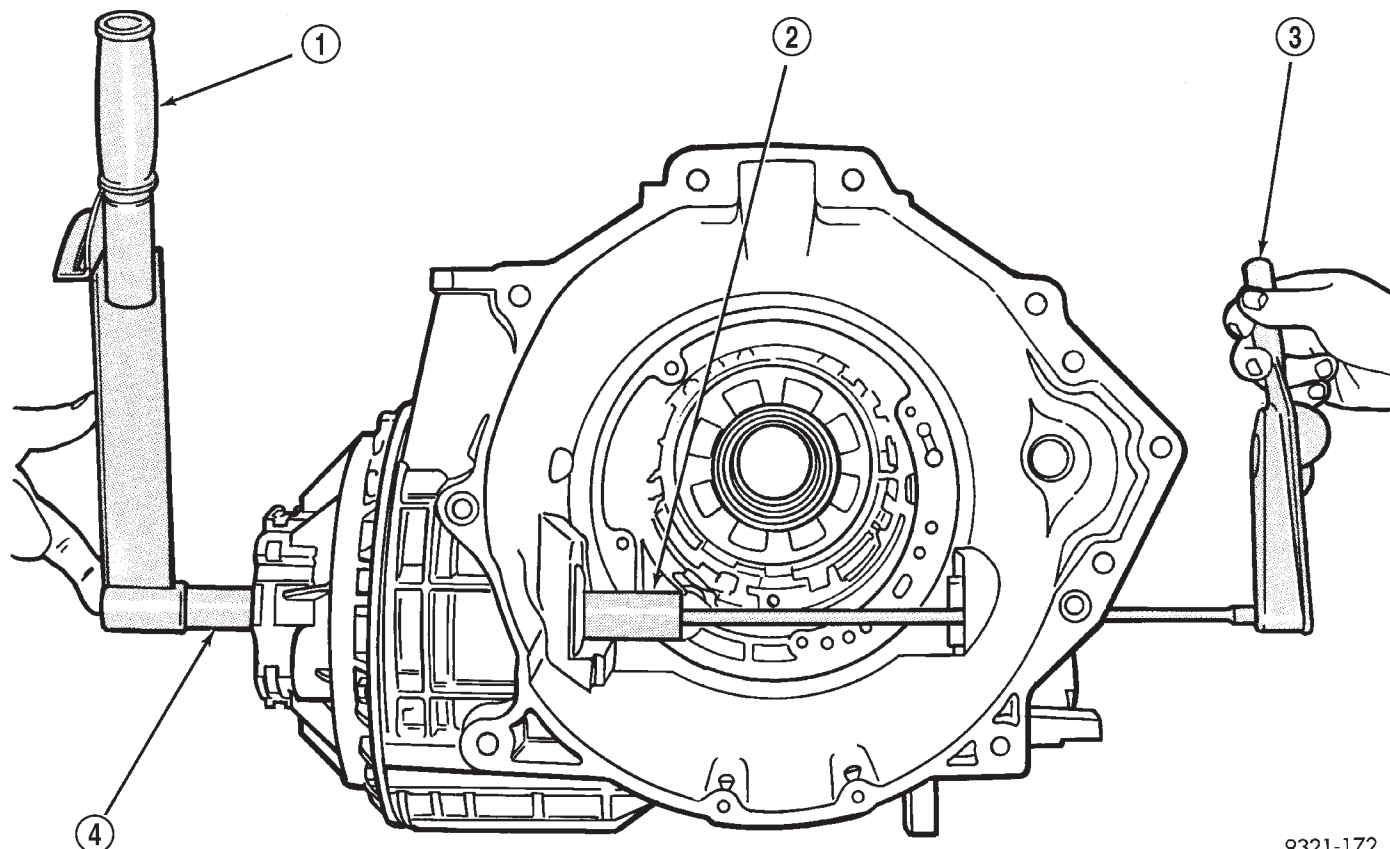

9321-172

Fig. 410 Determining Turning Torque

1 - FT. LBS. TORQUE WRENCH
2 - SPECIAL TOOL 6548

3 - IN. LBS. TORQUE WRENCH
4 - SPECIAL TOOL 6503

(33) Install transfer shaft into transaxle case (Fig. 411).

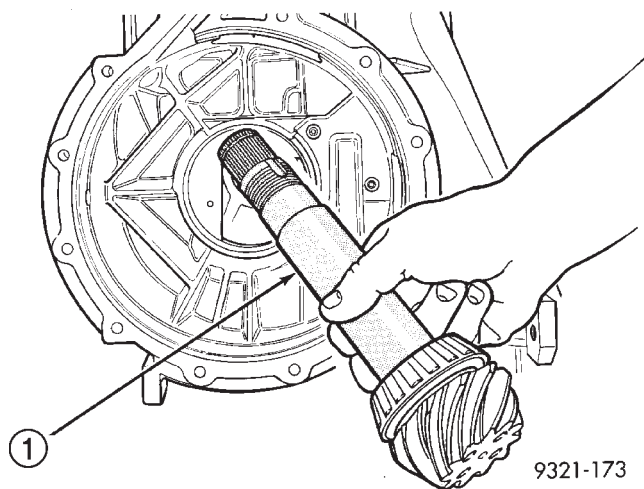

9321-173

Fig. 411 Transfer Shaft Installation

1 - TRANSFER SHAFT

CAUTION: Bottom of support fixture must be flush with face of bell housing. If the support fixture is not flush, the seals and rear transfer shaft bearing cup will be pressed in cocked.

(34) Install transfer shaft support fixture (special tool 6595) (Fig. 412).

(35) Install transfer shaft seal protector (special tool 6592) (Fig. 413). Apply thin film of gear oil to protector.

(36) Apply a small amount of lube to seal lips and install front transfer shaft seal. The serrated edges must face toward the rear of the transaxle (Fig. 414).

(37) Install seal with special tool 6567A (Fig. 415). Use a press to install seal. The installation tool will set the seal depth. Do not use a hammer to install seal. The seal may be damaged if installed with a hammer.

(38) Install rear transfer shaft seal. The seal must be installed so that the spring side of the seal faces the installation tool (Fig. 416). Use the same special tool (6567A) to install the seal. The installation tool will set the seal depth. Use a press to install this seal. Do not use a hammer.

DISASSEMBLY AND ASSEMBLY (Continued)

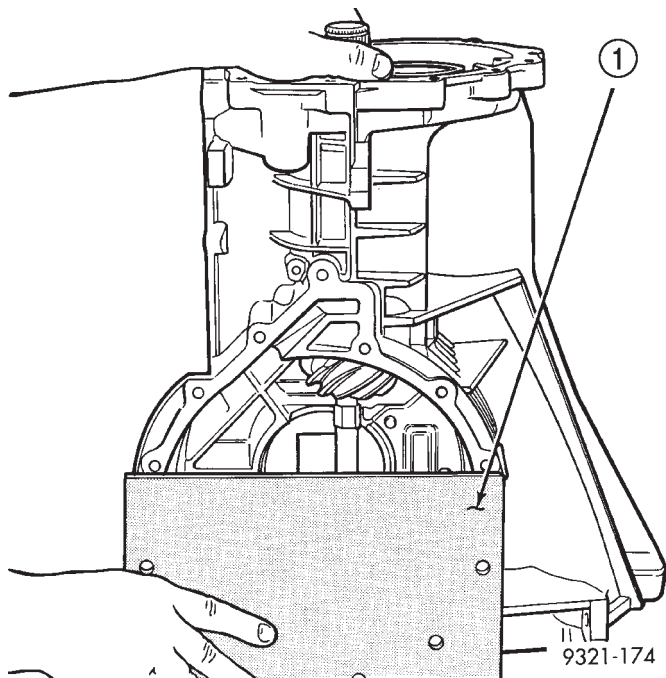

Fig. 412 Transfer Shaft Support Fixture

- 1 - SUPPORT FIXTURE (6595)

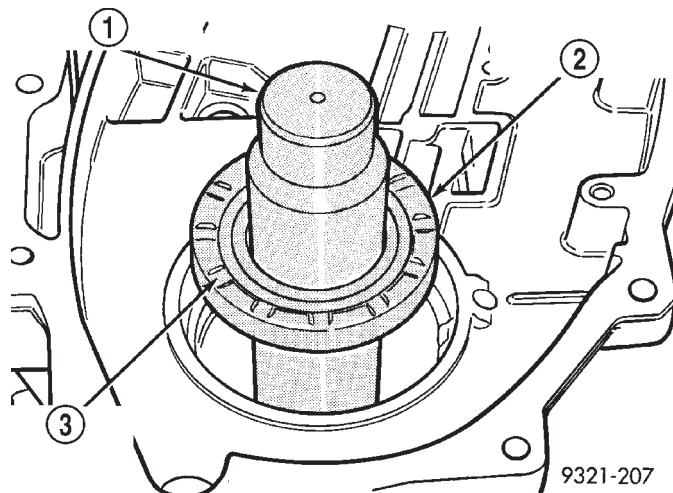

Fig. 414 Correct Seal Orientation

- 1 - SEAL PROTECTOR
2 - FRONT TRANSFER SHAFT SEAL
3 - SERRATED SIDE REARWARD

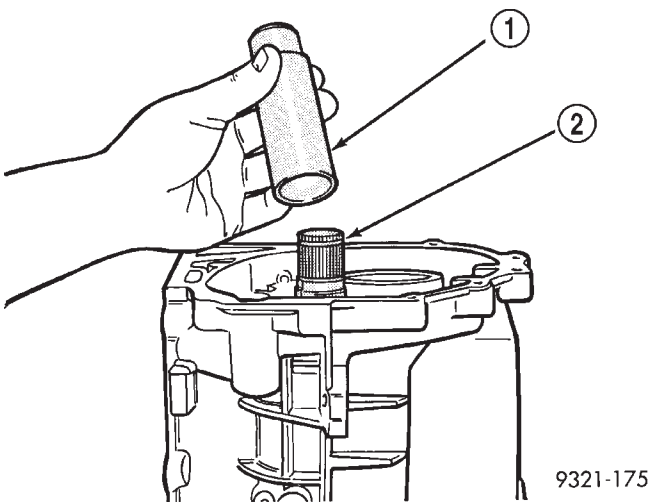

Fig. 413 Seal Protector Installation

- 1 - SEAL PROTECTOR
2 - TRANSFER SHAFT

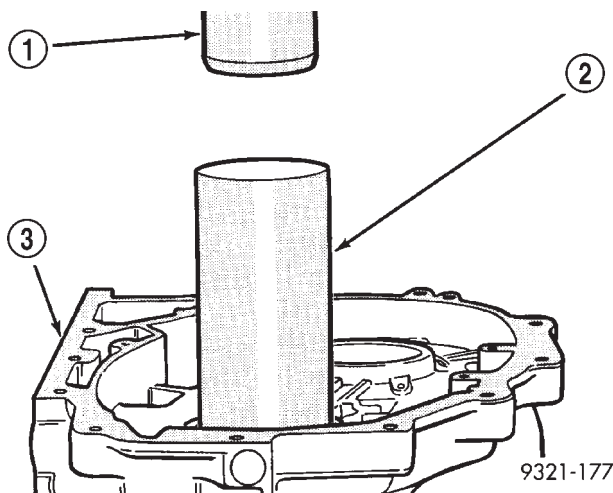

Fig. 415 Seal Installation

- 1 - ARBOR PRESS
2 - SEAL INSTALLER (6567A)
3 - TRANSAXLE CASE

CAUTION: Properly seated cups are essential in correctly setting bearing preload.

(39) Install rear transfer shaft cup into case (Fig. 417).

(40) Use special tool 6560 to press cup into case (Fig. 418).

DISASSEMBLY AND ASSEMBLY (Continued)

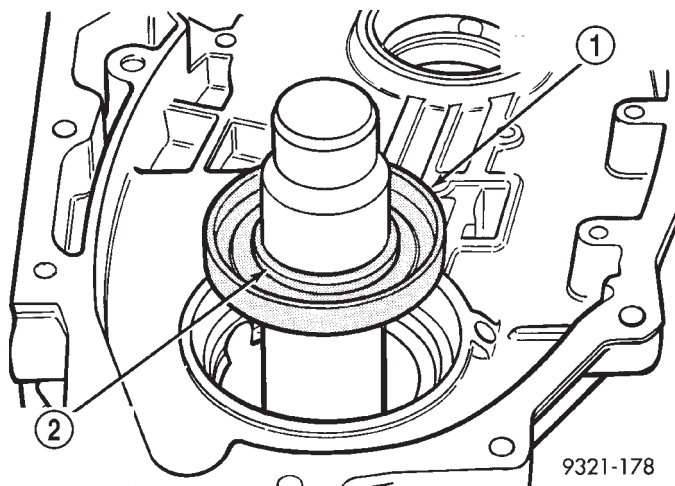

Fig. 416 Correct Seal Orientation

- 1 - REAR TRANSFER SHAFT SEAL
- 2 - SPRING SIDE OUTWARD

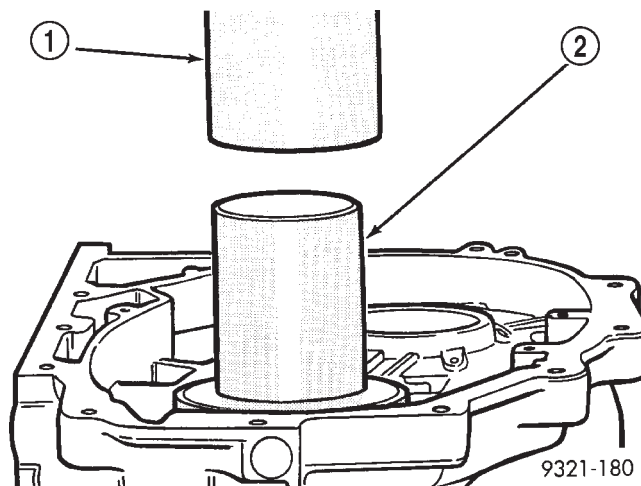

Fig. 418 Rear Transfer Shaft Cup Installation

- 1 - ARBOR PRESS
- 2 - SPECIAL TOOL 6560

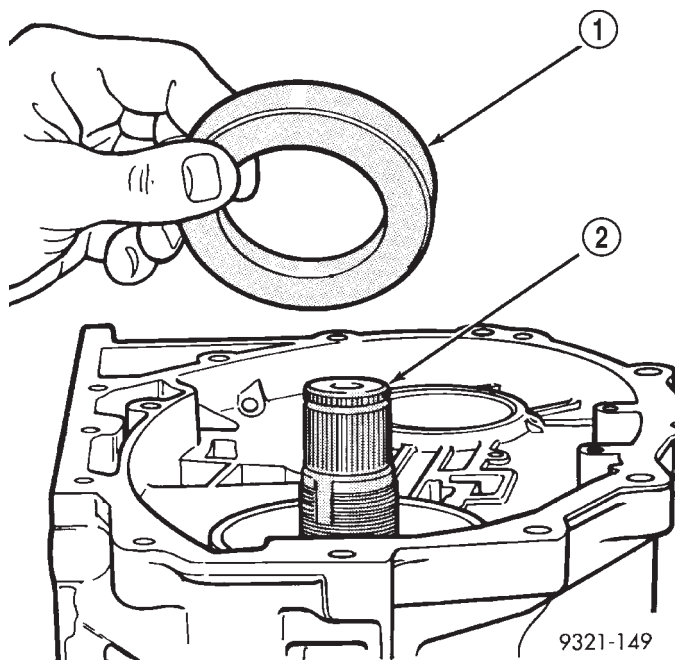

Fig. 417 Rear Transfer Bearing Cup

- 1 - REAR TRANSFER BEARING CUP
- 2 - TRANSFER SHAFT

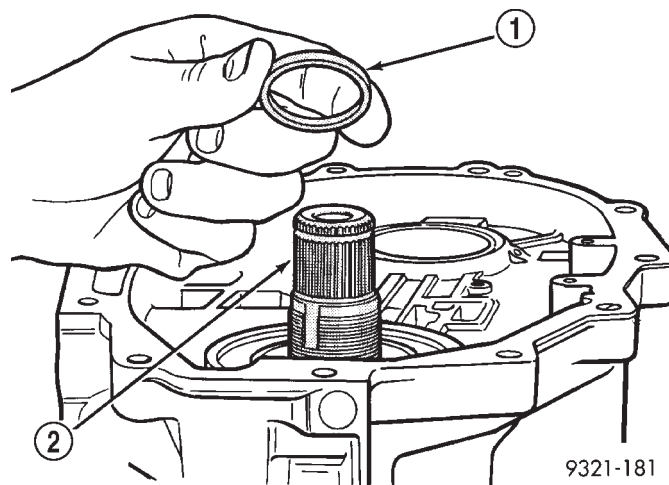

Fig. 419 Transfer Preload Shim Installation

- 1 - TRANSFER SHAFT PRELOAD SHIM
- 2 - TRANSFER SHAFT

CAUTION: Always use a new transfer shaft nut. Do not reuse old transfer shaft nut.

(41) Install Transfer shaft preload shim (Fig. 419). Use the original shim that was taken out of transaxle if possible. If original shim is not available, use the thickest shim as a starting point. Refer to Transfer Shaft Rear Shim Chart for available sizes.

(42) Install rear transfer shaft cone. Press cone on transfer shaft using Special Tool MD998805.

(43) Remove transfer shaft support fixture (special tool 6595).

(44) Install a new transfer shaft nut (Fig. 420). Tighten nut to 271 N·m (200 ft. lbs.). Use special tools 6497 holder and 6498 shaft socket to tighten nut.

CAUTION: Failure to set the transfer shaft turning torque correctly may cause transfer shaft bearings or seals to fail. Be sure transfer shaft does not have end play. If end play exists, install a thinner preload shim.

(45) Check the turning torque of the transfer shaft using a torque wrench (Fig. 421). The turning torque

DISASSEMBLY AND ASSEMBLY (Continued)

3.53 - 3.55 mm	4.13 - 4.15 mm
3.56 - 3.58 mm	4.16 - 4.18 mm
3.59 - 3.61 mm	4.19 - 4.21 mm
3.62 - 3.64 mm	4.22 - 4.24 mm
3.65 - 3.67 mm	4.25 - 4.27 mm
3.68 - 3.70 mm	4.28 - 4.30 mm
3.71 - 3.73 mm	4.31 - 4.33 mm
3.74 - 3.76 mm	4.34 - 4.36 mm
3.77 - 3.79 mm	4.37 - 4.39 mm
3.80 - 3.82 mm	4.40 - 4.42 mm
3.83 - 3.85 mm	4.43 - 4.45 mm
3.86 - 3.88 mm	4.46 - 4.48 mm
3.89 - 3.91 mm	4.49 - 4.51 mm
3.92 - 3.94 mm	4.52 - 4.54 mm
3.95 - 3.97 mm	4.55 - 4.57 mm
3.98 - 4.00 mm	4.58 - 4.60 mm
4.01 - 4.03 mm	4.61 - 4.63 mm
4.04 - 4.06 mm	4.64 - 4.66 mm
4.07 - 4.09 mm	4.67 - 4.69 mm
4.10 - 4.12 mm	

9421-69

Transfer Shaft Rear Shim Chart

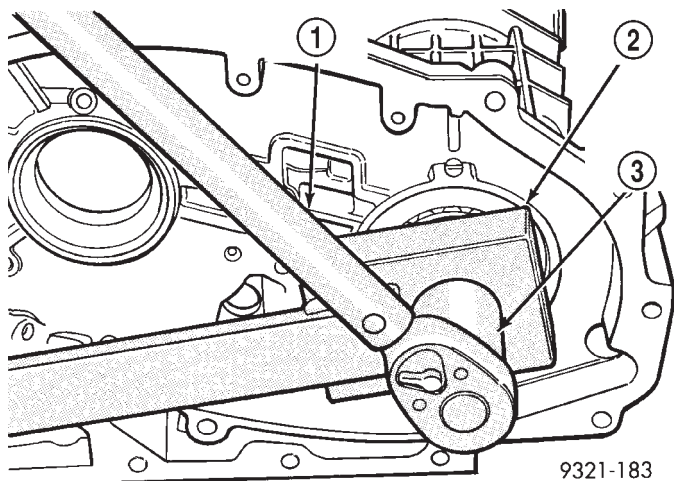

Fig. 420 Transfer Shaft Nut Installation

- 1 - TORQUE WRENCH
- 2 - HOLDER (6497)
- 3 - SHAFT SOCKET (6498)

should be 0.5 to 1.3 N·m (5 to 12 in. lbs.). If the turning torque is too high, install a thicker transfer shaft preload shim. If the turning torque is too low, install a thinner transfer shaft preload shim.

CAUTION: A press and special tool 6589 must be used when staking the transfer shaft nut. Do not use a hammer and the special tool to stake nut. If a hammer is used; seal, bearing, and/or tool damage may result. Also the stake will not be seated against the shaft correctly. This will allow the nut to loosen.

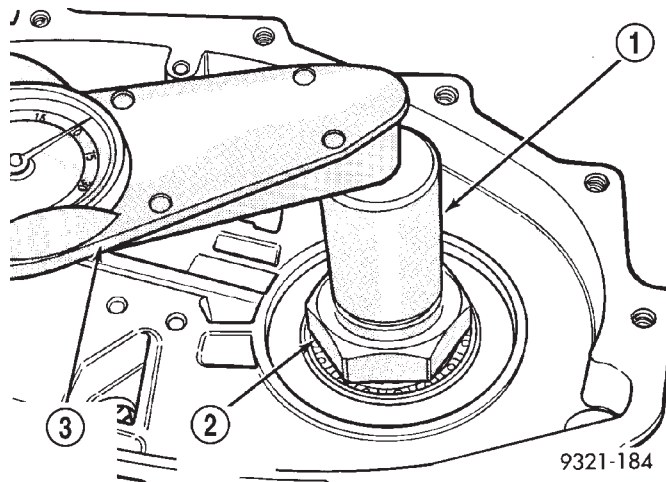

Fig. 421 Checking Turning Torque

- 1 - SOCKET (6498)
- 2 - TRANSFER SHAFT NUT
- 3 - IN. LBS. TORQUE WRENCH

(46) After the correct turning torque is obtained, use special tool 6589 to stake the new transfer shaft nut (Fig. 422). Be sure that the tool arms line up with slots in the transfer shaft. Use a press with the special tool to make the stakes in the nut.

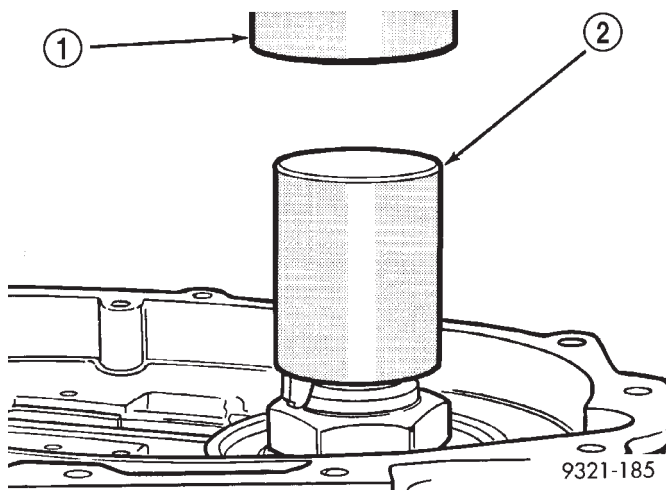

Fig. 422 Staking New Nuts

- 1 - ARBOR PRESS
- 2 - STAKING TOOL (6589)

CAUTION: Failure to stake the transfer shaft nut correctly may allow the nut to loosen during transaxle operation. This will cause transaxle failure.

(47) At this point the transfer shaft, new oil seals, pinion depth and transfer shaft preload have been set. The following steps will set the backlash between the transfer shaft and the ring gear.

DISASSEMBLY AND ASSEMBLY (Continued)

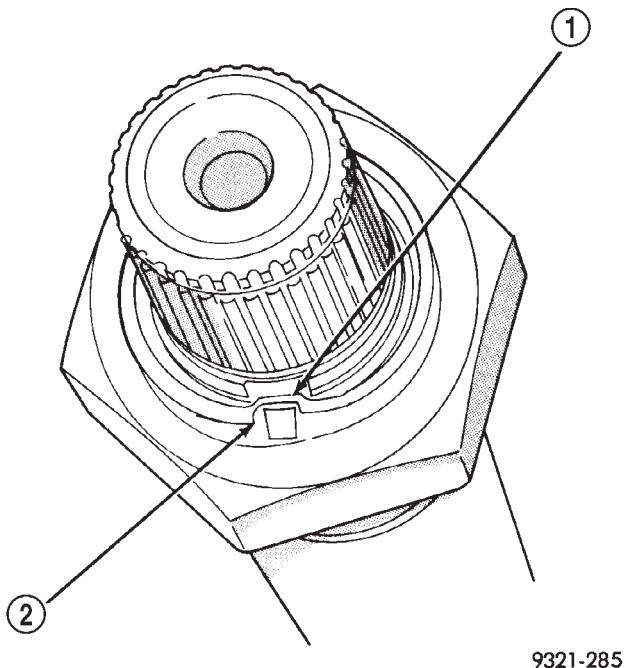

9321-285

Fig. 423 Correctly Staked Nut

- 1 - BOTTOMED IN SLOT
- 2 - CORRECTLY STAKED NUT

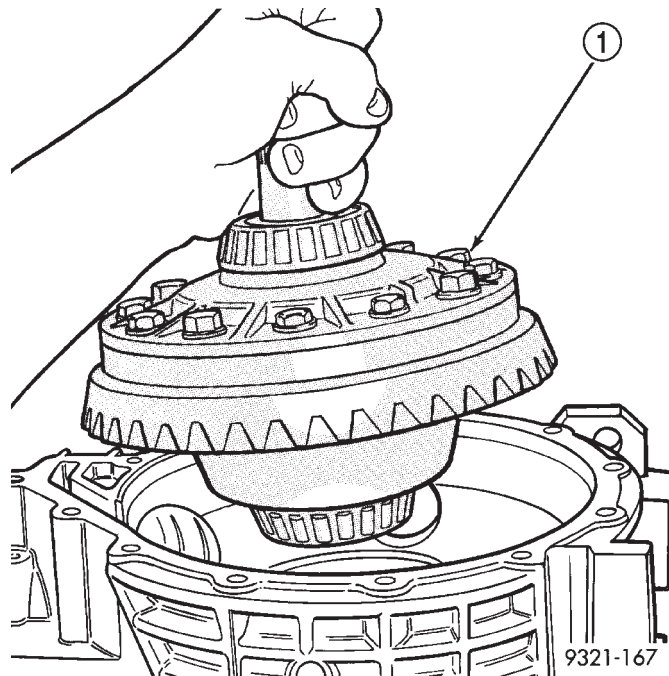

9321-167

Fig. 425 Differential Assembly Installation

- 1 - DIFFERENTIAL ASSEMBLY

(48) If the carrier requires reconditioning, refer to Differential Carrier Recondition.

(49) Install vent baffle. Apply sealer as shown in (Fig. 424).

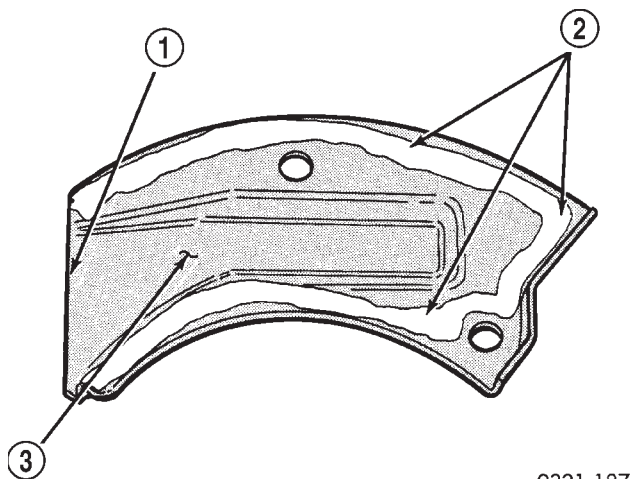

9321-187

Fig. 424 Baffle Installation

- 1 - NO SEALER ON THIS EDGE
- 2 - APPLY SEALER
- 3 - VENT BAFFLE

(50) Install new inner adjuster O-ring. Lube inner adjuster threads and O-ring. Then install inner adjuster flush with differential side of case.

(51) Install differential assembly (with ring gear attached) into transaxle case (Fig. 425).

(52) Transfer shaft to ring gear backlash should be 0.006" to 0.009" thousands of an inch. To get the backlash close enough to measure, perform the following steps. Hold the transfer shaft with one hand and rock the ring gear back and forth (Fig. 426). You should feel some backlash between the gears. If no backlash is felt use special tool 6502B to turn the inner adjuster so that it raises the differential assembly. This will increase backlash. If there is too much backlash, use special tool 6502B to turn the inner adjuster so that it lowers the differential assembly. This will decrease backlash. Recheck the backlash after each adjustment.

(53) Apply a 1/8 inch bead of sealant to differential cover flange. Then install differential cover with sealant (Fig. 427) and tighten cover bolts.

(54) Install seal protector (special tool 6591) on shaft (Fig. 428).

CAUTION: Lube threads and O-ring on adjuster before installing. Failure to do so will result in thread damage to the adjuster and differential cover.

(55) Install outer adjuster with new O-ring (Fig. 429). Torque the outer adjuster (special tool 6503) to the torque reading recorded in Step 30. Then seat bearings by turning differential three or four revolutions in both directions. Tighten adjuster a second time to same torque recorded in Step 30. Again

DISASSEMBLY AND ASSEMBLY (Continued)

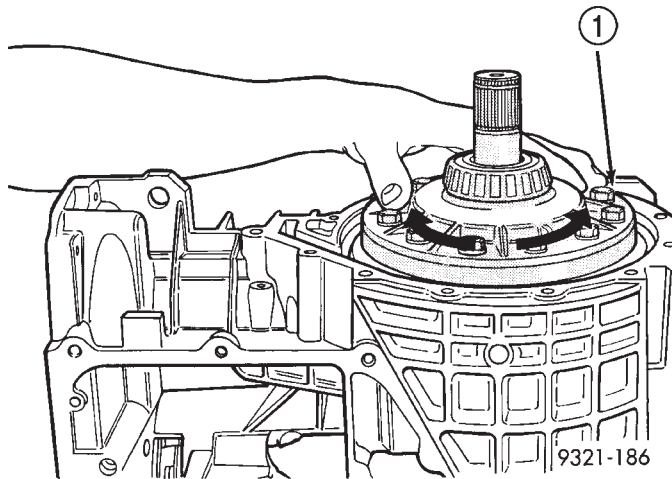

Fig. 426 Rocking Ring Gear Back and Forth

1 - DIFFERENTIAL ASSEMBLY

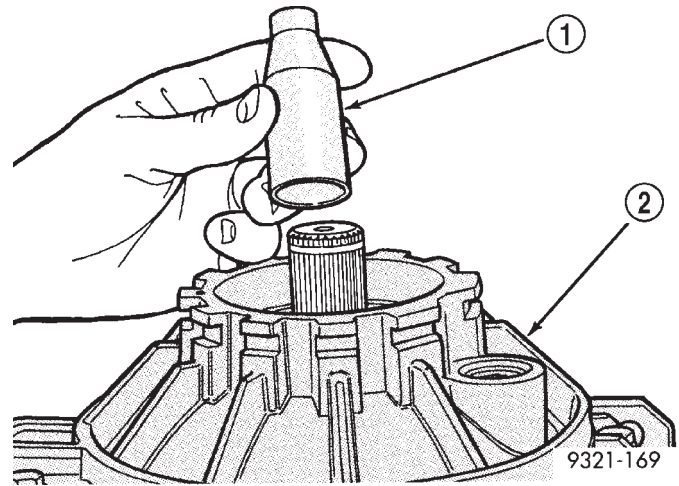

Fig. 428 Seal Protector

1 - SEAL PROTECTOR
(6591)
2 - SIDE COVER

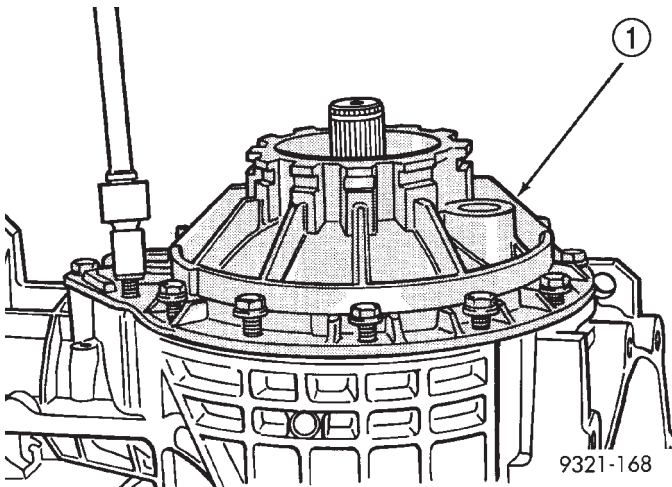

Fig. 427 Differential Cover Installation

1 - SIDE COVER

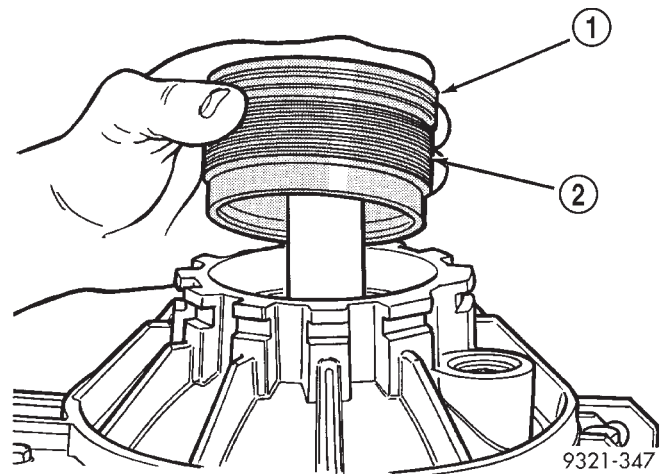

Fig. 429 Outer Adjuster Installation

1 - O-RING
2 - OUTER ADJUSTER

reseal bearings. Repeat this sequence until correct adjuster torque is maintained.

(56) To check and/or adjust backlash, remove the inspection plug from the top of the differential. Install dial indicator as shown in (Fig. 430). The tip of the dial indicator must be perpendicular against one of the ring gear teeth. Hold transfer shaft with locking pliers. Move ring gear back and forth with special tool 6548. Read the amount of backlash with dial indicator. Backlash should be 0.006" to 0.009" thousands of an inch.

(57) If there is too much backlash, loosen the outer adjuster with special tool 6503. Then turn the inner adjuster so that it **moves away from the ring gear**. After adjusting the inner adjuster, retighten the outer adjuster to the torque recorded in Step 30. The inner adjuster should be turned in small increments.

(58) If there is not enough backlash, loosen the outer adjuster with special tool 6503. Then turn the inner adjuster so that it **moves towards the ring gear**. After adjusting the inner adjuster, retighten the outer adjuster to the torque recorded in Step 30. The inner adjuster should be turned in small increments.

(59) Once backlash is within specifications, recheck backlash in four spots on the ring gear 90 degrees apart. All four readings should be within specifications.

(60) Install inner and outer adjuster locking brackets.

(61) Install new inspection plug. Use a wooden block to tap inspection plug into place.

DISASSEMBLY AND ASSEMBLY (Continued)

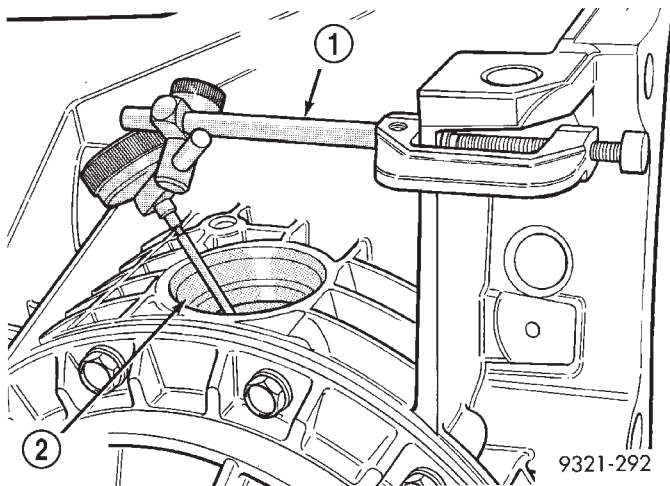

Fig. 430 Dial Indicator Installation

- 1 - DIAL INDICATOR KIT C-3339
- 2 - ACCESS HOLE

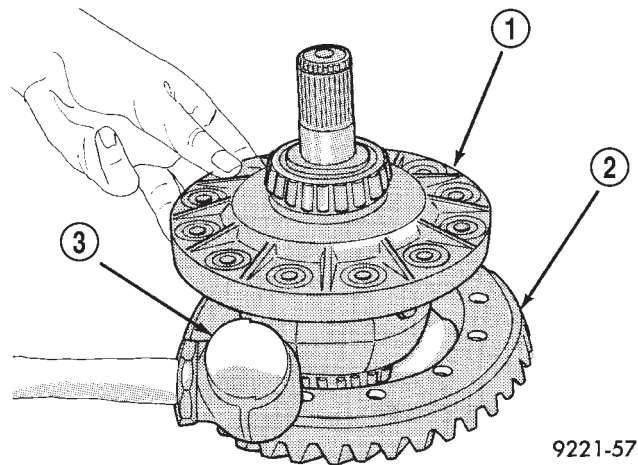

Fig. 432 Tap Off Ring Gear

- 1 - DIFFERENTIAL CARRIER
- 2 - RING GEAR
- 3 - PLASTIC Mallet

(62) It is easier to fill the differential prior to installing the transaxle back into the vehicle. The differential holds 32 ounces of fluid.

DIFFERENTIAL CARRIER-RECONDITION

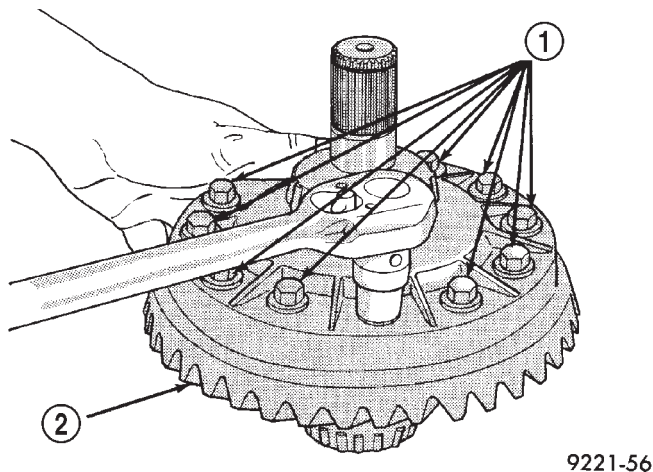

Fig. 431 Remove Ring Gear Bolts

- 1 - RING GEAR BOLTS
- 2 - RING GEAR

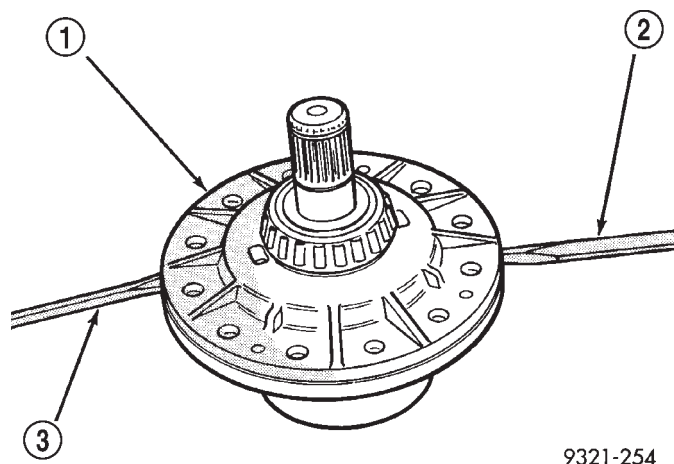

Fig. 433 Pry Differential Carrier Apart

- 1 - DIFFERENTIAL CARRIER
- 2 - PRY TOOL
- 3 - PRY TOOL

NOTE: When reassembling differential, line up notches on side of carrier.

CAUTION: When reassembling use a new roll pin.

CAUTION: Ring gear bolts are not reusable. When reassembling use new bolts.

NOTE: To remove inner and outer adjuster races, use Tool 6062-A. To install inner and outer adjuster races, use Tool 6522 and Tool C-4171.

NOTE: Mark ring gear location, if reusing ring gear.

DISASSEMBLY AND ASSEMBLY (Continued)

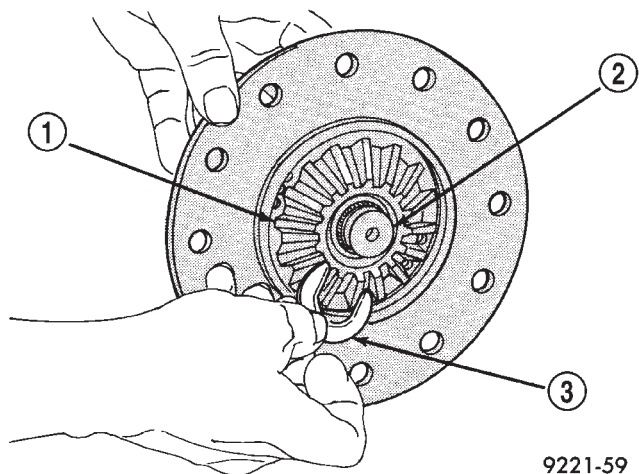

Fig. 434 Remove C-Clip

- 1 - SIDE GEAR
- 2 - STUB SHAFT
- 3 - "C" CLIP

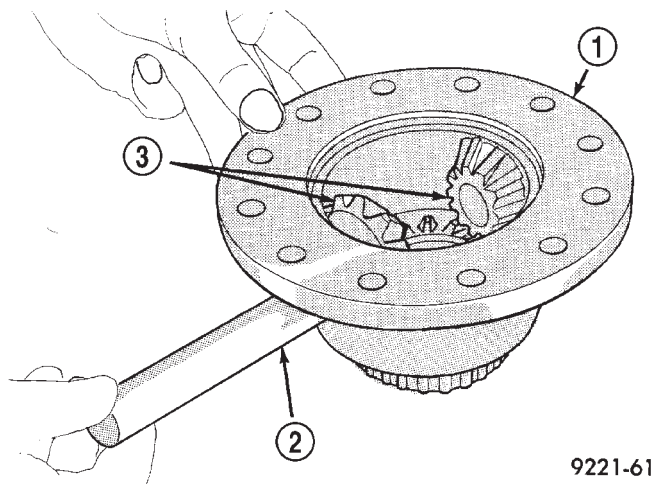

Fig. 436 Slide Out Differential Pinion Shaft and Remove Pinion Gears and Side Gears

- 1 - DIFFERENTIAL CARRIER
- 2 - PINION SHAFT
- 3 - SIDE GEARS

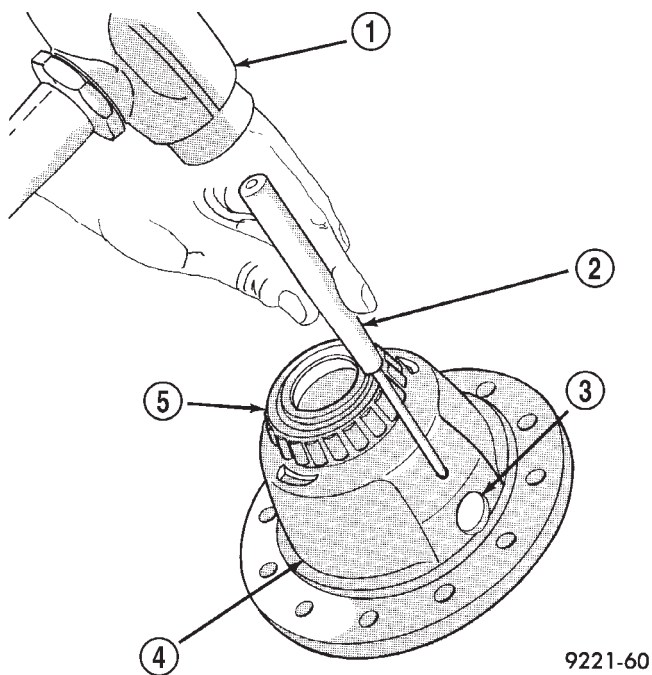

Fig. 435 Remove Pinion Shaft Roll Pin

- 1 - HAMMER
- 2 - PIN PUNCH
- 3 - PINION SHAFT
- 4 - DIFFERENTIAL CARRIER
- 5 - DIFFERENTIAL BEARING

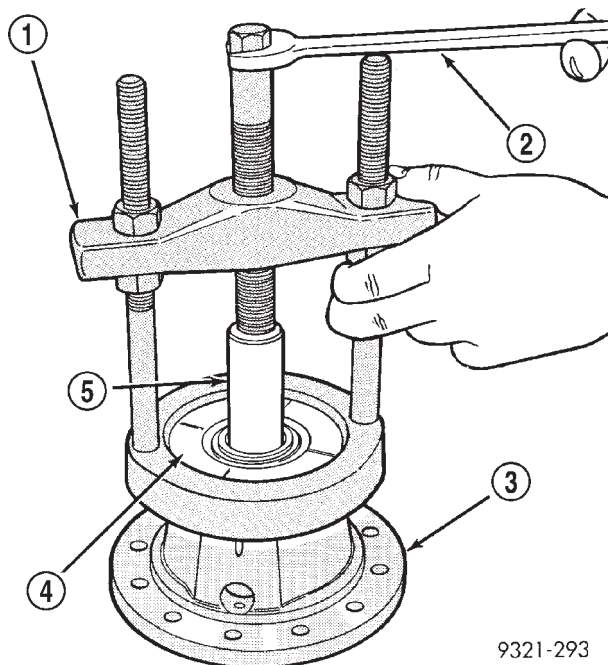

Fig. 437 Carrier Bearing Removal

- 1 - SPECIAL TOOL C-293 PA
- 2 - WRENCH
- 3 - DIFFERENTIAL CARRIER
- 4 - SPECIAL TOOL JAWS (4) C-293-48
- 5 - SPECIAL TOOL C-4496

DISASSEMBLY AND ASSEMBLY (Continued)

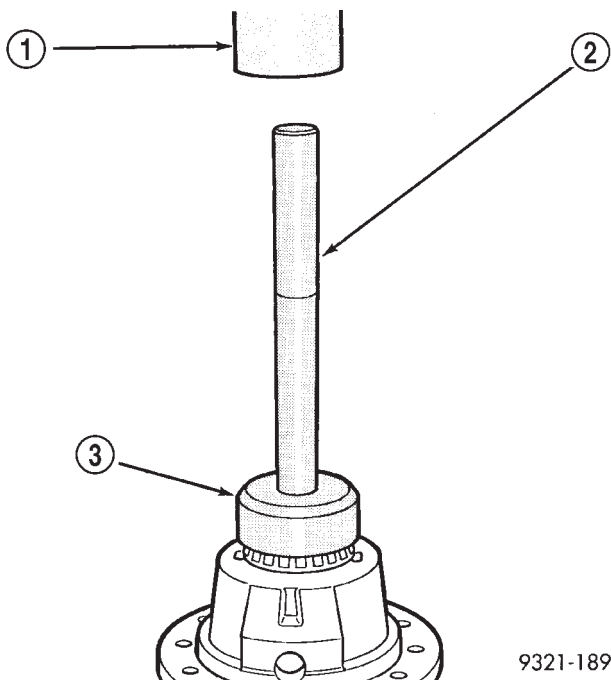

Fig. 438 Carrier Bearing Installation

- 1 - ARBOR PRESS
- 2 - HANDLE C-4171
- 3 - SPECIAL TOOL C-4340

- (2) Pry the chains down at the center of the chains.
- (3) Butt a scale against the snubber and mark the scale at the bottom of the chains (Fig. 440).

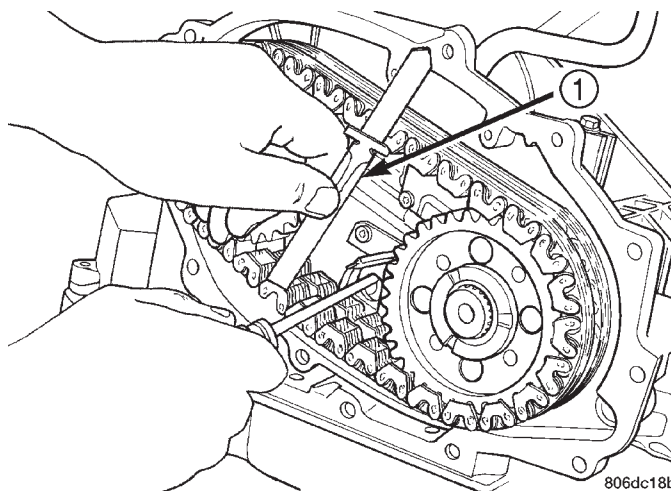

Fig. 440 Chain Measurement

- 1 - SCALE

CLEANING AND INSPECTION

TRANSFER CHAINS LENGTH MEASUREMENT

The need to replace the transfer chains because of excessive wear is unlikely. If chain length is suspected to be long, perform the following procedure to measure the chain length:

- (1) Insert a screwdriver into the 18 mm hole with the screwdriver **ABOVE** the chains (Fig. 439).

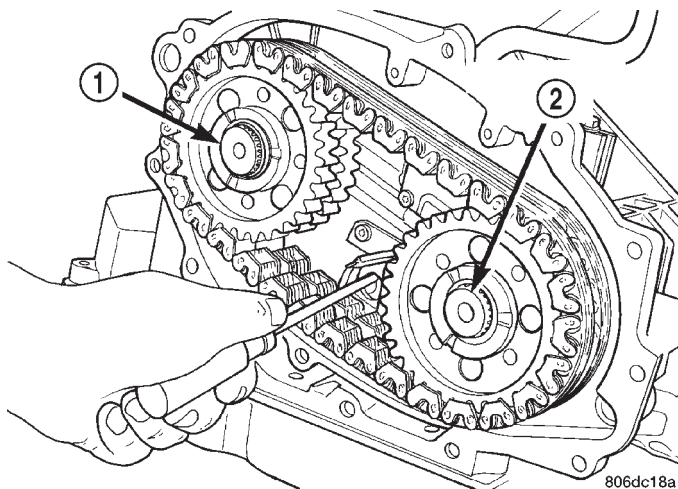

Fig. 439 Screwdriver Placement

- 1 - OUPUT SHAFT
- 2 - TRANSFER SHAFT

- (4) Insert a screwdriver into the 18 mm hole with the screwdriver **BELOW** the chains (Fig. 441). An assistant may be needed to perform this step.

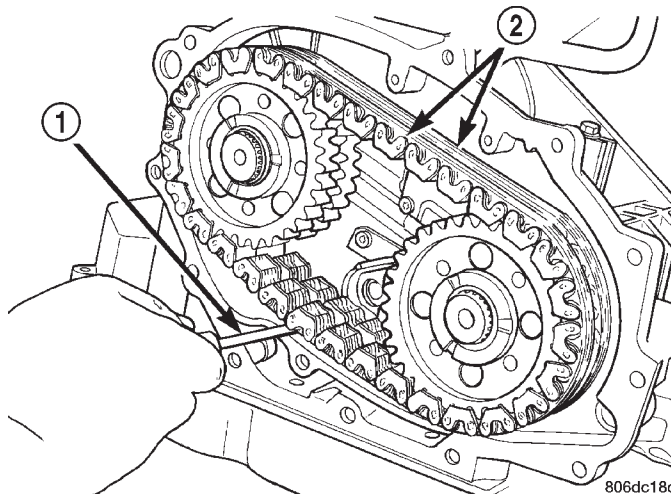

Fig. 441 Screwdriver Placement

- 1 - PRY TOOL
- 2 - CHAINS

- (5) Pry the chains up at the center of the chain.
- (6) Butt a scale against the snubber and place a second mark on the scale at the bottom of the chains (Fig. 442).
- (7) Measure the distance between the two marks placed on the scale (Fig. 443). If the two marks on the scale are more than one inch apart, replace the drive chains.

CLEANING AND INSPECTION (Continued)

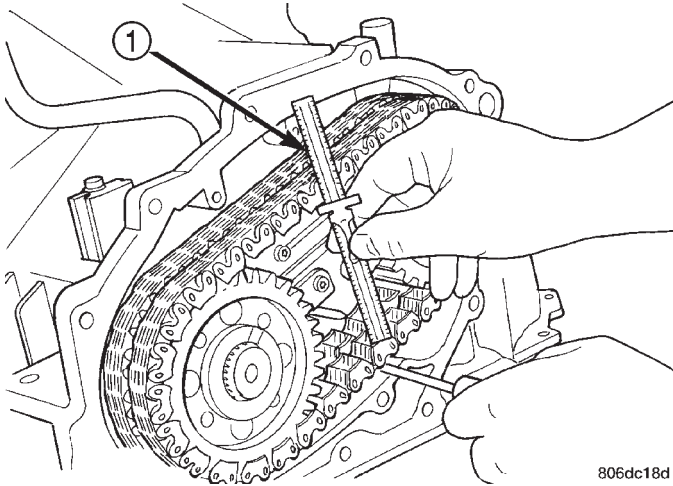

Fig. 442 Chains Measurement

1 - SCALE

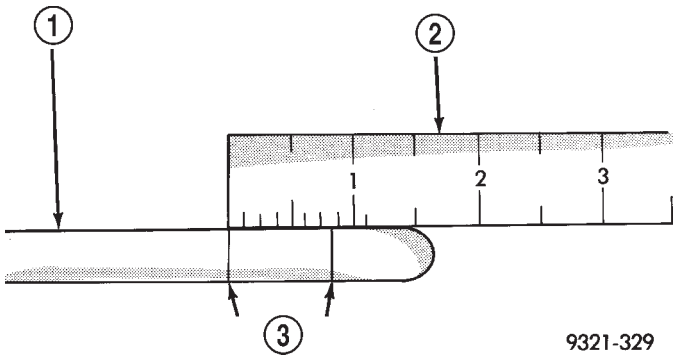

Fig. 443 Measuring Marks on Scale

1 - SCALE
2 - RULER
3 - MARKS PLACED ON SCALE

ADJUSTMENTS

GEARSHIFT CABLE-COLUMN SHIFT

The gearshift cable should be adjusted if any of the following repairs or situations are encountered:

- Transaxle replacement.
- Valve body repair.
- Shift cable replacement.
- Column shifter replacement.
- When there is no cranking in Park or Neutral.

If the following conditions are encountered, the interlock cable is out of adjustment. Refer to Interlock Cable Adjustment procedure.

- When the transaxle can be shifted without the key in the ignition.
- If the key can be removed with the shifter in reverse.
- When the key cannot be removed with the shifter in the park position.

ADJUSTMENT

- (1) Remove upper steering column shroud.
- (2) Rotate cable adjuster into unlock position. Use a straight blade screwdriver to unlock adjuster (Fig. 444).

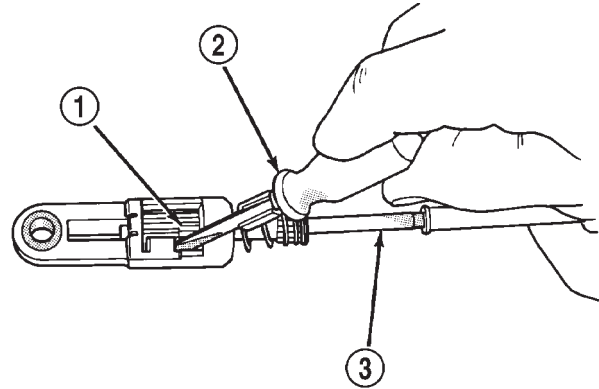

Fig. 444 Cable Lock Mechanism

1 - CABLE ADJUSTER LOCK
2 - SCREWDRIVER
3 - SHIFT CABLE

- (3) Make sure that the transaxle shift lever (at transaxle) is in the Park position. This is the most rearward position. Verify park sprag is fully engaged.

CAUTION: Park sprag must be engaged when adjusting linkage. Rock vehicle back and forth to ensure that park sprag is fully engaged.

- (4) Tilt the steering column to the full down position.
- (5) Place shifter in the park position with the key removed.
- (6) Adjust by rotating adjuster into lock position (Fig. 445).
- (7) Reinstall upper steering column shroud.
- (8) Check shifter for proper operation. It should operate smoothly without binding. The vehicle should crank in Park or Neutral only.

GEARSHIFT CABLE-FLOOR SHIFT

The gearshift cable should be adjusted if any of the following repairs or situations are encountered:

- Transaxle replacement.
- Valve body repair.
- Shift cable replacement.
- Floor shifter replacement
- When there is no cranking in park or neutral.

If the following conditions are encountered, the interlock cable is out of adjustment. Refer to Interlock Cable Adjustment procedure.

ADJUSTMENTS (Continued)

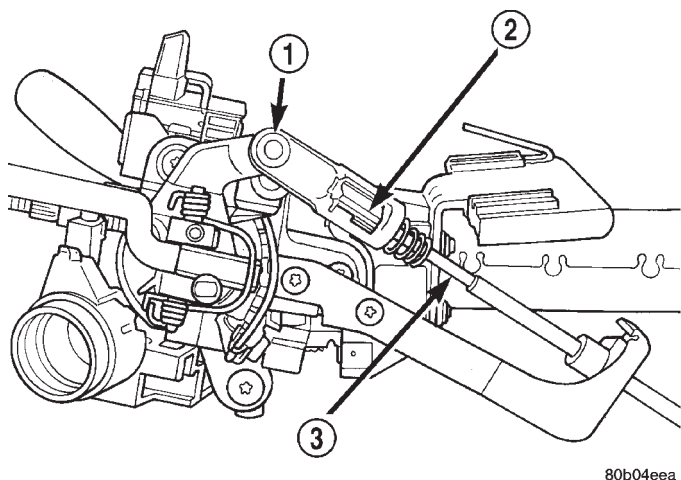

80b04eea

Fig. 445 Shift Cable Adjuster Lock

- 1 - SHIFTER PIN
- 2 - CABLE ADJUSTER LOCK
- 3 - SHIFTER CABLE

- When the transaxle can be shifted without the key in the ignition.
- If the key can be removed with the shifter in reverse.
- When the key cannot be removed with the shifter in the park position.

ADJUSTMENT

- (1) Remove shifter handle and console bezel.
- (2) Loosen nut on shifter cable adjuster (Fig. 446).

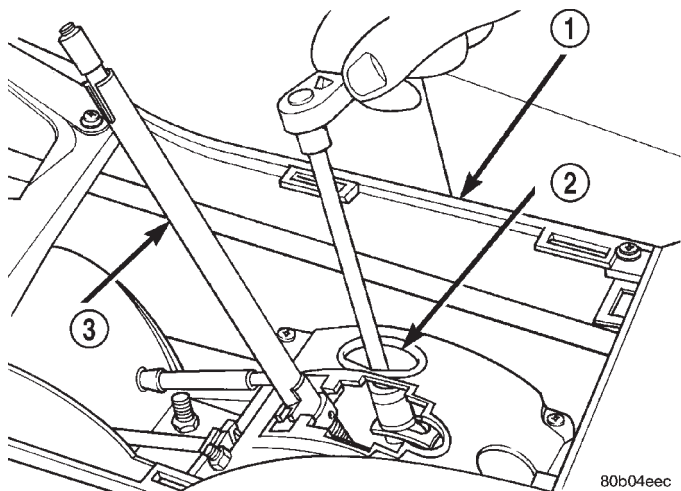

80b04eec

Fig. 446 Shift Cable Adjust Lever Nut

- 1 - CONSOLE
- 2 - ACCESS HOLE
- 3 - SHIFTER HANDLE

(3) Make sure that the transaxle shift lever (at transaxle) is in the Park position. This is the most rearward position. Verify park sprag is fully engaged.

CAUTION: Park sprag must be engaged when adjusting linkage. Rock vehicle back and forth to ensure that park sprag is fully engaged.

- (4) Place shifter in park position.
- (5) Place ignition in lock with key removed.
- (6) Tighten adjuster nut at shifter to 225 in. lbs.
- (7) Reinstall console bezel and shifter handle.
- (8) Check shifter for proper operation. It should operate smoothly without binding. The vehicle should crank in Park or Neutral only.

BRAKE/TRANSMISSION SHIFT INTERLOCK (FLOOR)

- (1) Remove the shifter handle.
- (2) Remove the console bezel.
- (3) Move the gear shifter to PARK and the ignition key to the LOCK position (Fig. 447).
- (4) If the interlock cable is being replaced, remove the pin to allow cable to "self adjust." Press locking clip (Fig. 448) by hand to secure adjustment.
- (5) If the interlock cable is not being replaced, the pin will not exist. Loosen the locking clip (Fig. 448) on the interlock cable to allow cable to "self adjust." Press locking clip (Fig. 448) by hand to secure adjustment.

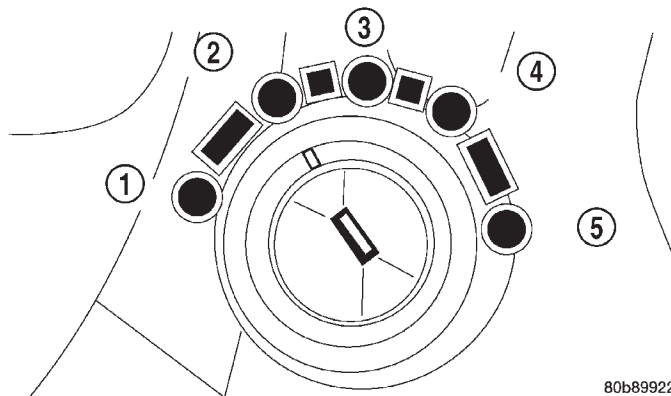

80b89922

Fig. 447 Ignition Key/Switch Positions

- 1 - ACC
- 2 - LOCK
- 3 - OFF
- 4 - ON/RUN
- 5 - START

ADJUSTMENTS (Continued)

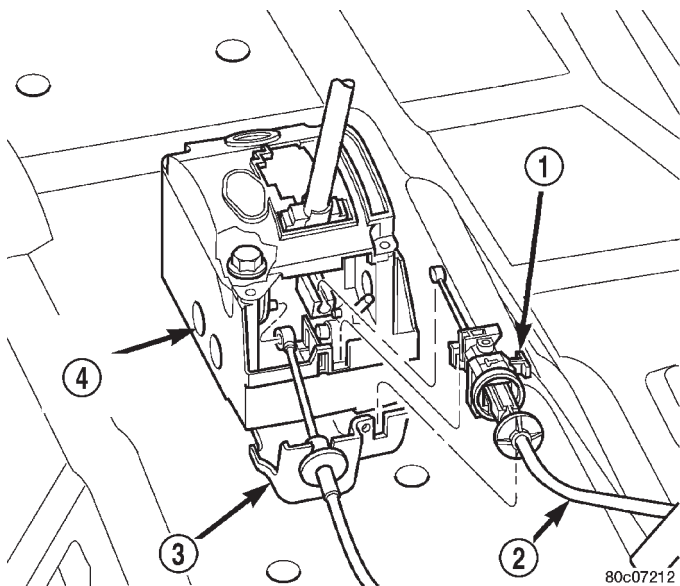

Fig. 448 Interlock Cable at Shifter Assy.

- 1 - LOCKING CLIP
- 2 - INTERLOCK CABLE
- 3 - BRACKET
- 4 - SHIFTER ASSEMBLY

- (6) Install the bezel on the shifter console.
- (7) Install shifter handle.

AUTOSTICK

The autostick switch is serviced as an assembly with the gearshift mechanism. The switch is not adjustable. If a problem occurs with the switch, refer to the Diagnosis and Testing section.

BEARING ADJUSTMENT PROCEDURES

Take extreme care when removing and installing bearing cups and cones. **Use only an arbor press for installation**, as a hammer may not properly align the bearing cup or cone. Burrs or nicks on the bearing seat will give a false end play reading, while gauging for proper shims. Improperly seated bearing cup and cones are subject to low-mileage failure.

Bearing cups and cones should be replaced if they show signs of pitting or heat distress.

If distress is seen on either the cup or bearing rollers, both cup and cone must be replaced.

NOTE: Bearing end play and drag torque specifications must be maintained to avoid premature bearing failures.

Used (original) bearing may lose up to 50 percent of the original drag torque after break-in.

NOTE: All bearing adjustments must be made with no other component interference or gear intermesh, except the transfer gear bearing.

Oil all bearings before checking turning torque.

MASTER SHIM CHART

Use this chart as a reference guide when selecting the shims needed for the:

- Transfer Shaft
- Output Shaft
- Output Sprocket
- Pinion

ACTION	EXPECTED RESPONSE
1. Turn key to the "OFF" position.	1. Shifter CAN be shifted out of park.
2. Turn key to the "ON/RUN" position.	2. Shifter CANNOT be shifted out of park.
3. Turn key to the "ON/RUN" position and depress the brake pedal.	3. Shifter CAN be shifted out of park.
4. Leave shifter in any gear and try to return key to the "LOCK" or "ACC" position.	4. Key cannot be returned to the "LOCK" or "ACC" position.
5. Return shifter to "PARK" and try to remove the key.	5. Key can be removed (after returning to "LOCK" position).
6. With the key removed, try to shift out of "PARK".	6. Shifter cannot be shifted out of "PARK".
NOTE: Any failure to meet these expected responses requires system adjustment or repair.	

ADJUSTMENTS (Continued)

TRANSFER SHAFT REAR SHIMS	
3.53 - 3.55	4.13 - 4.15
3.56 - 3.58	4.16 - 4.18
3.59 - 3.61	4.19 - 4.21
3.62 - 3.64	4.22 - 4.24
3.65 - 3.67	4.25 - 4.27
3.68 - 3.70	4.28 - 4.30
3.71 - 3.73	4.31 - 4.33
3.74 - 3.76	4.34 - 4.36
3.77 - 3.79	4.37 - 4.39
3.80 - 3.82	4.40 - 4.42
3.83 - 3.85	4.43 - 4.45
3.86 - 3.88	4.46 - 4.48
3.89 - 3.91	4.49 - 4.51
3.92 - 3.94	4.52 - 4.54
3.95 - 3.97	4.55 - 4.57
3.98 - 4.00	4.58 - 4.60
4.01 - 4.03	4.61 - 4.63
4.04 - 4.06	4.64 - 4.66
4.07 - 4.09	4.67 - 4.69
4.10 - 4.12	

PINION HEAD SHIMS	
0.681 - 0.707	0.924 - 0.950
0.708 - 0.734	0.951 - 0.977
0.735 - 0.761	0.978 - 1.004
0.762 - 0.788	1.005 - 1.031
0.789 - 0.815	1.032 - 1.058
0.816 - 0.842	1.059 - 1.085
0.843 - 0.869	1.086 - 1.112
0.870 - 0.896	1.113 - 1.139
0.897 - 0.923	

OUTPUT SHAFT REAR SHIMS	
5.17 - 5.19	5.62 - 5.64
5.20 - 5.22	5.65 - 5.67
5.23 - 5.25	5.68 - 5.70
5.26 - 5.28	5.71 - 5.73
5.29 - 5.31	5.74 - 5.76
5.32 - 5.34	5.77 - 5.79
5.35 - 5.37	5.80 - 5.82
5.38 - 5.40	5.83 - 5.85
5.41 - 5.43	5.86 - 5.88
5.44 - 5.46	5.89 - 5.91
5.47 - 5.49	5.92 - 5.94
5.50 - 5.52	5.95 - 5.97
5.53 - 5.55	5.98 - 6.00
5.56 - 5.58	6.01 - 6.03
5.59 - 5.61	6.04 - 6.06

OUTPUT SPROCKET SPACER SHIMS	
2.64 - 2.84	3.48 - 3.68
2.85 - 3.05	3.69 - 3.89
3.06 - 3.26	3.90 - 4.10
3.27 - 3.47	4.11 - 4.31

ADJUSTMENTS (Continued)

DRIVE SPROCKET HEIGHT ADJUSTMENT PROCEDURE

A spacer beneath the output sprocket is used to position the output sprocket in line with the transfer sprocket. The sprocket must be within 0.015" of each other. In order to do this operation, install original spacer over the output shaft. If original spacer is not available, use the thickest available shim as a starting point. Refer to Output Sprocket Spacer Chart for available sizes. Then install the two sprockets without the chain.

The chain sprockets are not reversible. Check the height difference using a straight edge (special tool 6311 or equivalent) and a set of feeler gauges.

If the output sprocket is lower than transfer sprocket, add the amount measured to the shim that was installed (Fig. 449).

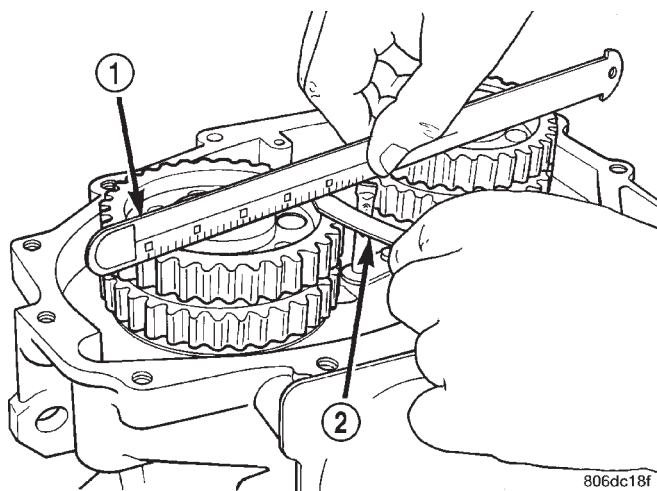

Fig. 449 Checking Sprocket Height

- 1 - STRAIGHT EDGE
- 2 - FEELER GAUGE

If the output sprocket is higher than transfer sprocket, subtract the amount measured to the shim that was installed (Fig. 450).

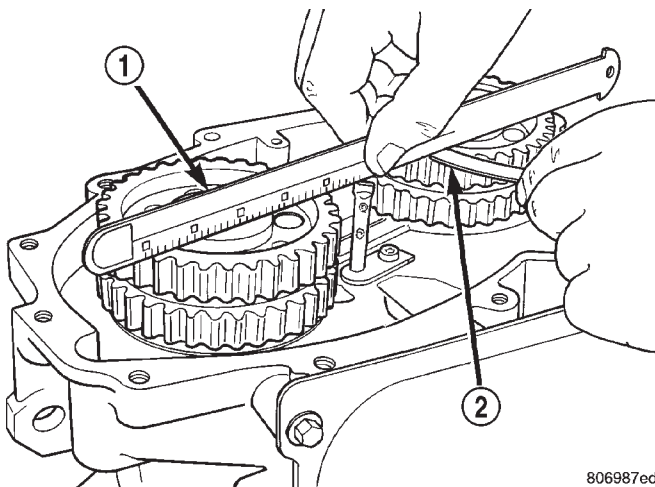

Fig. 450 Checking Sprocket Height

- 1 - STRAIGHT EDGE
- 2 - FEELER GAUGE

2.64 - 2.84 mm	3.48 - 3.68 mm
2.85 - 3.05 mm	3.69 - 3.89 mm
3.06 - 3.26 mm	3.90 - 4.10 mm
3.27 - 3.47 mm	4.11 - 4.31 mm

9421-68

OUTPUT SPROCKET SPACER CHART

SCHEMATICS AND DIAGRAMS

42LE TRANSAXLE HYDRAULIC SCHEMATICS

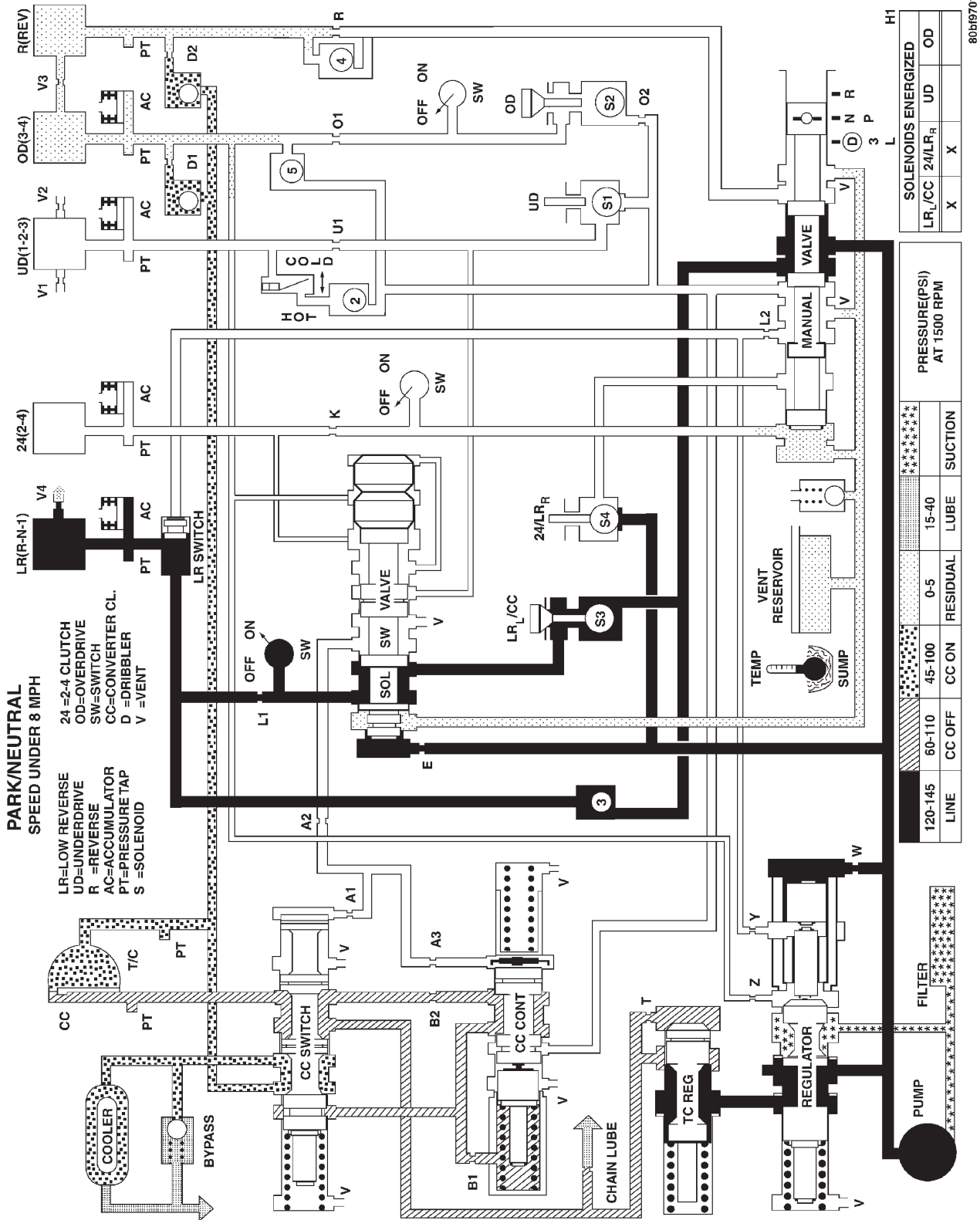

42LE TRANSAXLE HYDRAULIC SCHEMATIC

SCHEMATICS AND DIAGRAMS (Continued)

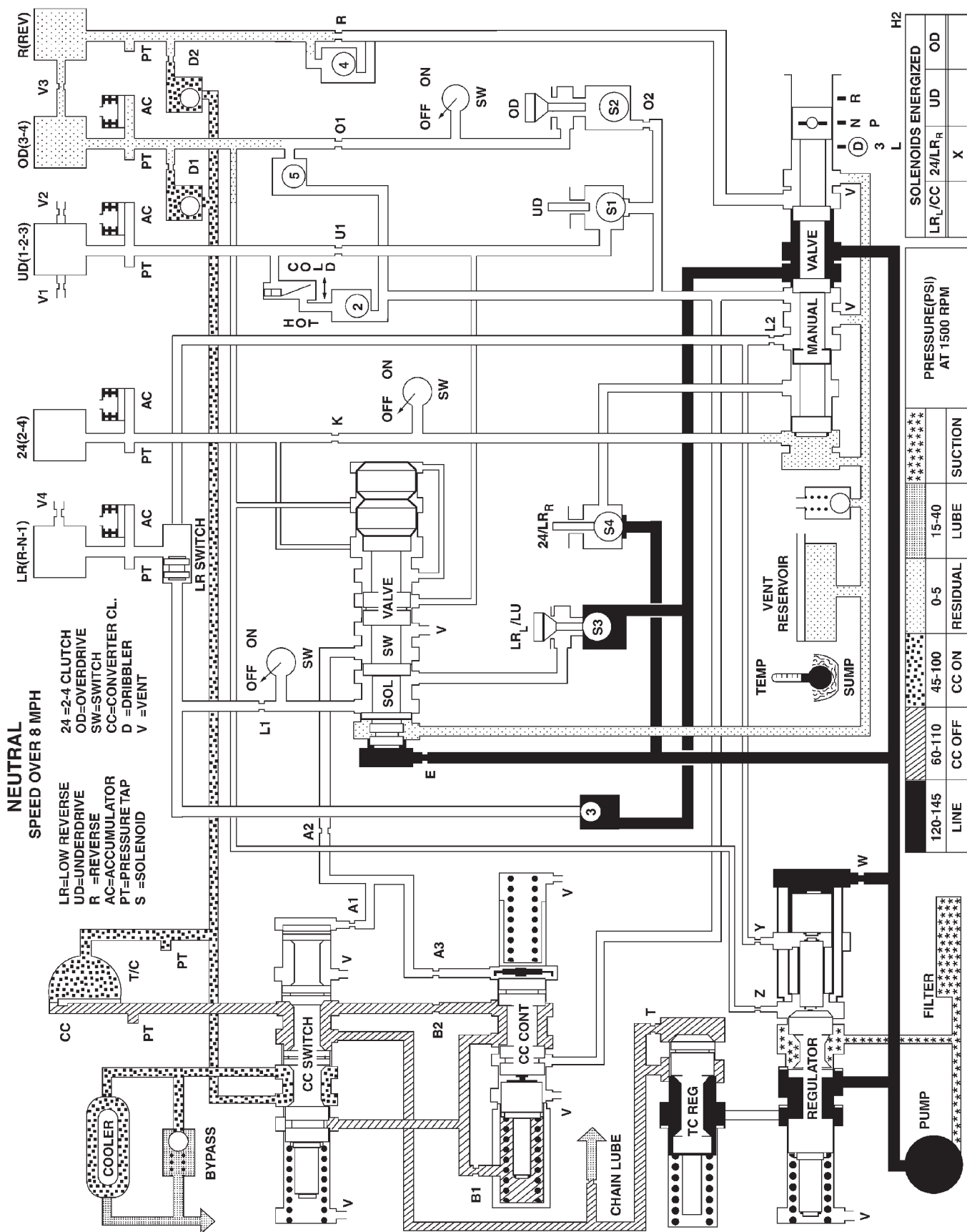

42LE TRANSAXLE HYDRAULIC SCHEMATIC

SCHEMATICS AND DIAGRAMS (Continued)

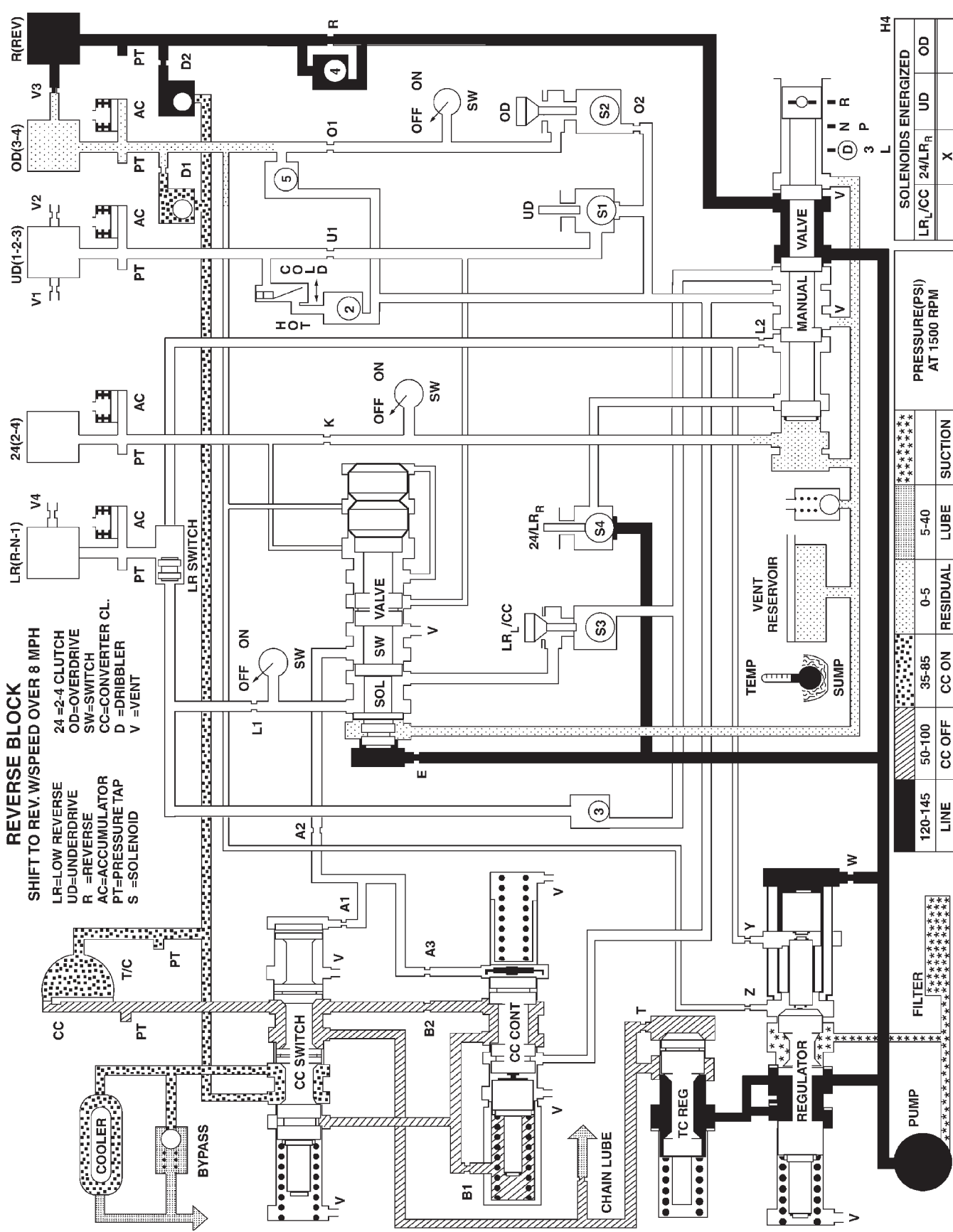

80b16704

42LE TRANSAXLE HYDRAULIC SCHEMATIC

SCHEMATICS AND DIAGRAMS (Continued)

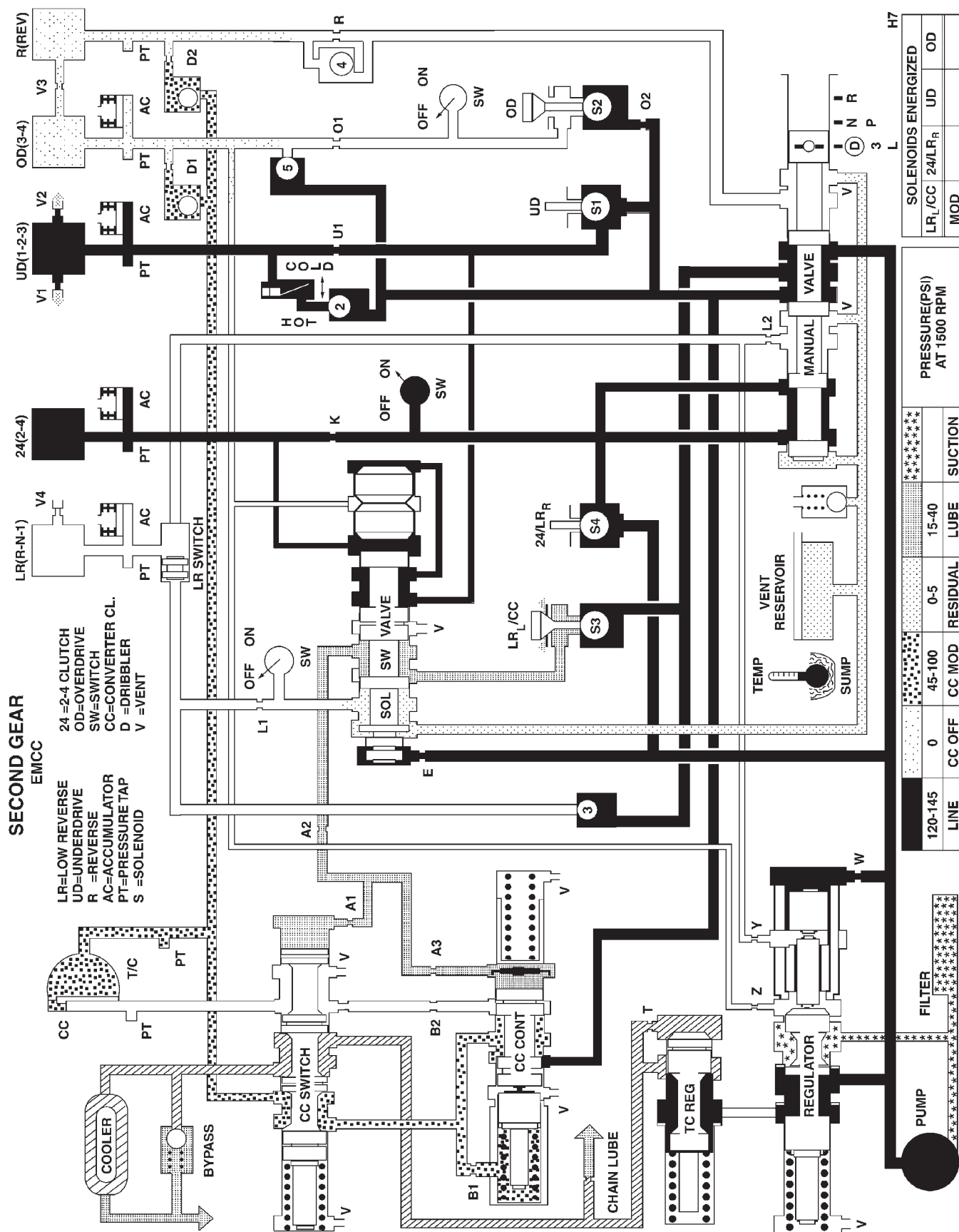

80516707

PRESSURE (PSI) AT 1500 RPM		SUCTION		LUBE		RESIDUAL		CC MOD		CC OFF		LINE	
0	45-100	0-5	15-40	0-5	15-40	0-5	15-40	0-5	15-40	0-5	15-40	120-145	120-145

42LE TRANSAXLE HYDRAULIC SCHEMATIC

SOLENOIDS ENERGIZED	
LR _L /CC	24/LR _R
MOD	OD

SCHEMATICS AND DIAGRAMS (Continued)

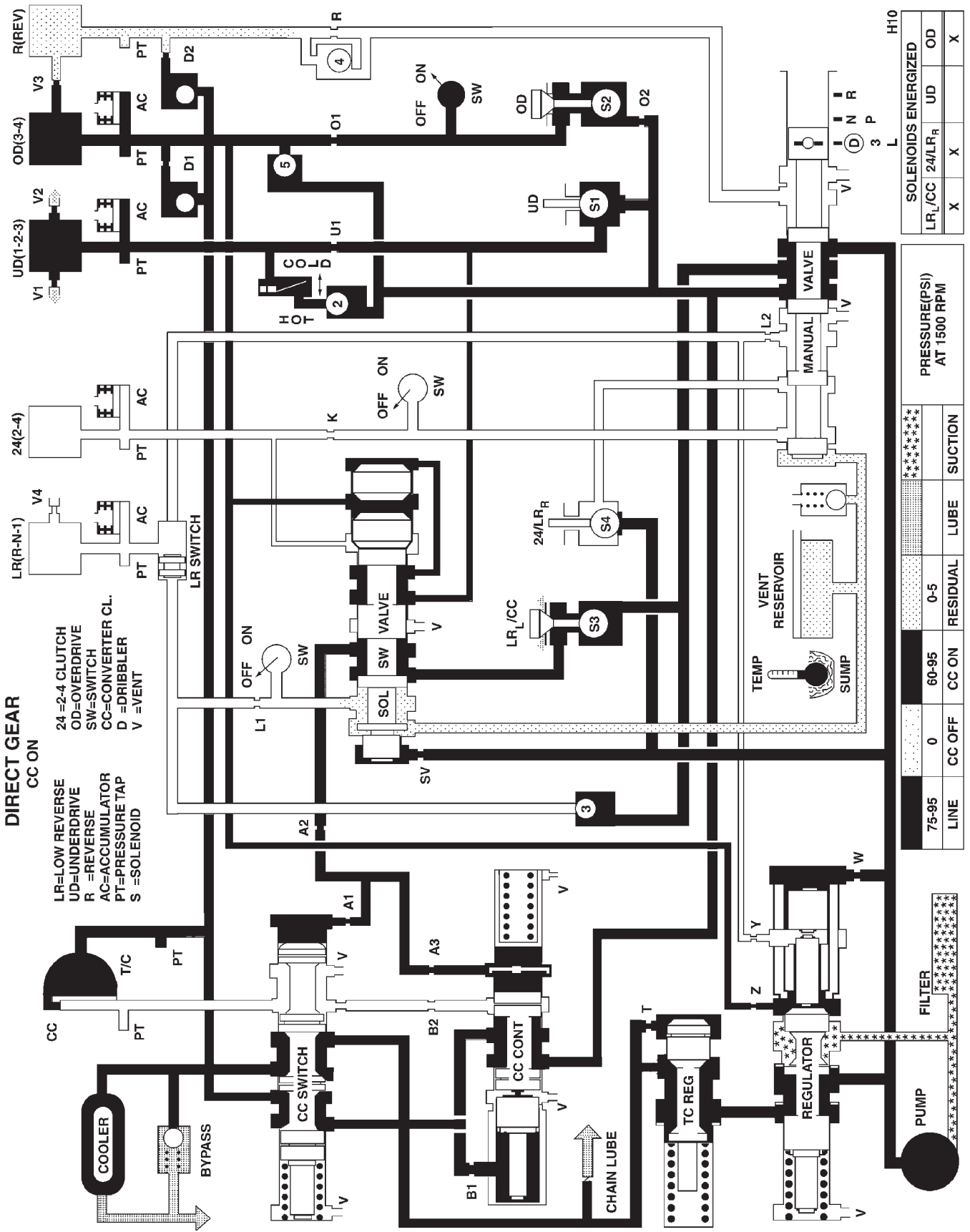

42LE TRANSAXLE HYDRAULIC SCHEMATIC

80516710

SPECIFICATIONS

42LE AUTOMATIC TRANSAXLE

Type Longitudinally Mounted, Fully Adaptive,
Electronically Controlled, Four Speed Automatic.
Electronically Modulated Torque Converter.
Separate Sump Differential
Torque Converter Diameter 254 millimeters
(10.00 in.)

Oil Capacity

Transmission Sump 9.4 Liters (9.9 qts.)
Differential Sump 0.95 Liters (1.0 qts.)

Oil Type

Transmission Sump Mopar® ATF+4 Type 9602
Differential Sump Mopar® Fuel Saving 75W-90
Petroleum Based Hypoid Gear Lube

Cooling Method Water Heat Exchanger and/or
Air to Oil Heat Exchanger

Lubrication Pump (internal-external gear-type)

Gear Ratios

Transmission Portion

First Gear 2.84
Second Gear 1.57
Direct Gear 1.00
Overdrive Gear 0.69
Reverse Gear 2.21

Overall Top Gear Ratio (In Overdrive)

2.7L 2.68
3.2, 3.5L 2.52

Output Shaft Sprocket Teeth Count

2.7L 31 Teeth
3.2, 3.5L 32 Teeth

Transfer Sprocket Teeth Count

2.7L 34 Teeth
3.2, 3.5L 33 Teeth

Final Drive Ratio

2.7L 3.89
3.2L/3.5L 3.66

Pump Clearances

Outer Gear To Pocket 0.045-0.141mm
(0.0018-0.0056 in.)
Outer Gear Side Clearance 0.020-0.046mm
(0.0008-0.0018 in.)
Inner Gear Side Clearance 0.020-0.046mm
(0.0008-0.0018 in.)

Bearing Preload

Differential Assembly 7 to 30 in. lbs. Drag Torque
Output Shaft 1 to 8 in. lbs. Drag Torque

Bearing Preload

Transfer Shaft 1 to 8 in. lbs. Drag Torque
Overall Drag At Output Hub 10 to 60 in. lbs.
Drag Torque

Sprocket Set Variance

Height Variance ±.457mm (± 0.018 in.)

Differential Backlash

Backlash Setting14 to.27mm
(0.0045 to 0.0105 in.)

Clutch Pack Clearances

Low/Rev Clutch (Select Reaction
Plate) 0.89-1.04 mm (0.035-0.060 in.)
Two/Four Clutch (No Selection) 0.76-2.64 mm
(0.030-0.104 in.)
Reverse Clutch (Select Snap Ring) 0.89-1.37 mm
(0.035-0.054 in.)
Overdrive Clutch (No Selection) 1.07-3.25 mm
(0.042-0.128 in.)
Underdrive Clutch (Select Pressure
Plate) 0.94-1.50 mm (0.037-0.059 in.)
Input Shaft End Play 0.12-0.63 mm
(0.005-0.025 in.)

42LE TRANSAXLE TORQUE SPECIFICATIONS

DESCRIPTION	TORQUE
Adj. Lock Bracket	5 N·m (45 in. lbs.)
Cooler Line Conn.	18 N·m (155 in. lbs.)
Diff. Ass. Partial Bolts	8 N·m (71 in. lbs.)
Diff. Cover Case	28 N·m (250 in. lbs.)
Differential Drain Plug	7 N·m (62 in. lbs.)
Differential Fill Plug	47 N·m (35 ft. lbs.)
Diff. Ring Gear Bolts	95 N·m (70 ft. lbs.)
Diff. Vent Baffle Screw	5 N·m (45 in. lbs.)
Differential Vent	11 N·m (100 in. lbs.)
Driveplate To Crank Bolts	95 N·m (70 ft. lbs.)
End Cover To Case	28 N·m (250 in. lbs.)
Fluid Filter Screw	5 N·m (45 in. lbs.)
Input Sensor To Case	27 N·m (240 in. lbs.)
Low/rev. Clutch Ret. To Case	5 N·m (45 in. lbs.)
Main Sump Vent Screw	5 N·m (45 in. lbs.)
Main Sump Vent	11 N·m (100 in. lbs.)
Man. Lev. To Valve Body	5 N·m (45 in. lbs.)
Oil Pan To Trans. Case Screw	23 N·m (17 ft. lbs.)
Output Sensor To Case	27 N·m (240 in. lbs.)
Output Shaft Nut	271 N·m (200 ft. lbs.)
Park Sprag Ret. Screw	5 N·m (45 in. lbs.)
Pressure Check Plug	6 N·m (53 in. lbs.)
Pump To Case Bolts	29 N·m (250 in. lbs.)
React. Shaft Ass. Bolt	28 N·m (250 in. lbs.)
Snubber Screws	5 N·m (45 in. lbs.)
Sol. Ass. To Transfer Plate	6 N·m (53 in. lbs.)
Solenoid Wiring Conn. Ret.	6 N·m (53 in. lbs.)

SPECIFICATIONS (Continued)

DESCRIPTION	TORQUE
Torque Conv. To Driveplate	88 N·m (65 ft. lbs.)
Transmission Mount	61 N·m (45 ft. lbs.)
Transfer Shaft Stake Nuts	271 N·m (200 ft. lbs.)
Valve Body Assy	12 N·m (105 in. lbs.)
Valve Body Screw	5 N·m (45 in. lbs.)
Wiring Harn. Tie Down	6 N·m (53 in. lbs.)

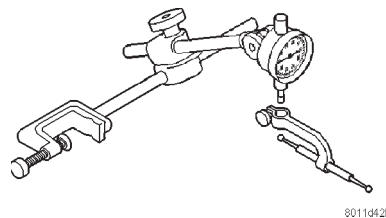

SPECIAL TOOLS

42LE AUTOMATIC TRANSAXLE

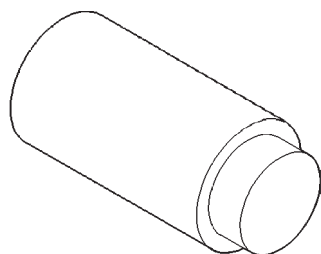

Puller Press Extension C-293-3

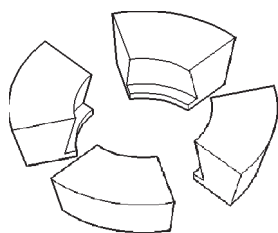

Adapter Blocks C-293-48

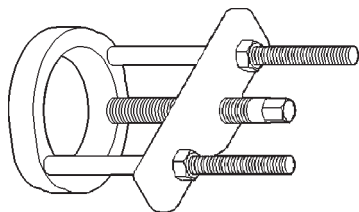

Puller Press C-293-PA

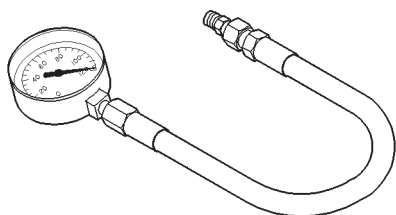

Pressure Gauge (High) C-3293SP

Dial Indicator C-3339

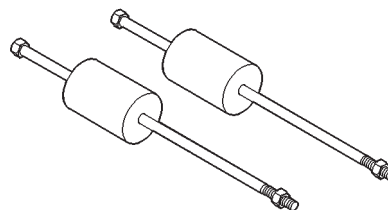

Slide Hammer C-3752

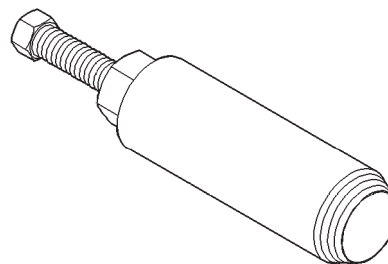

Seal Puller C-3981B

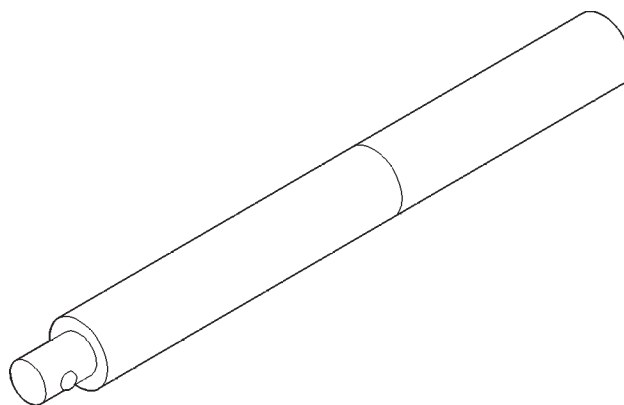

Universal Handle C-4171

SPECIAL TOOLS (Continued)

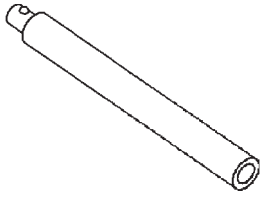

Handle Extension C-4171-2

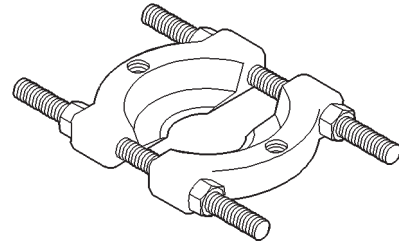

Bearing Splitter P-334

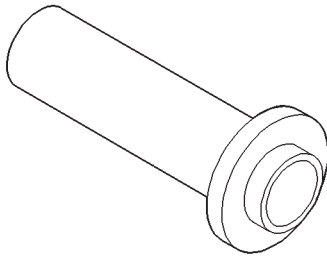

Seal Installer C-4193A

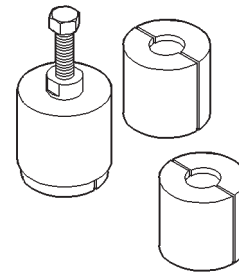

Puller Set 5048

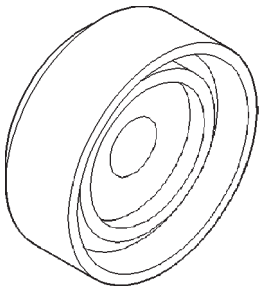

Installer C-4340

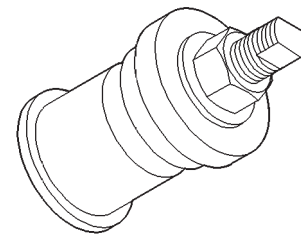

Installer 5050A

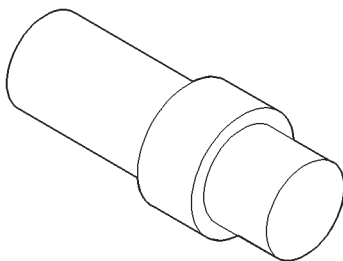

Adapter C-4996

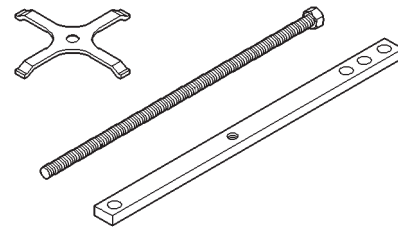

Compressor 5058A

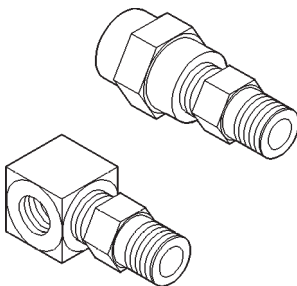

Adapter Set L-4559

SPECIAL TOOLS (Continued)

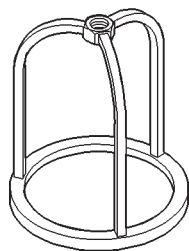

Compressor 5059-A

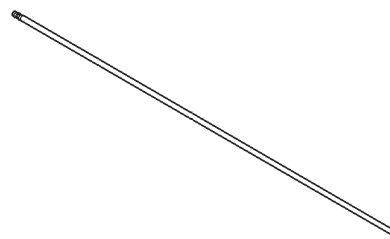

Tip 6268

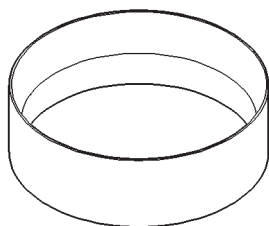

Installer 5067

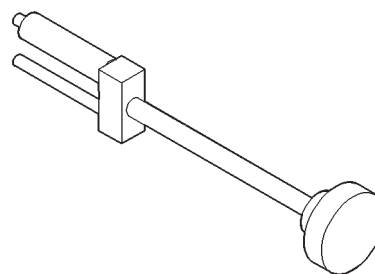

Remover/Installer 6301

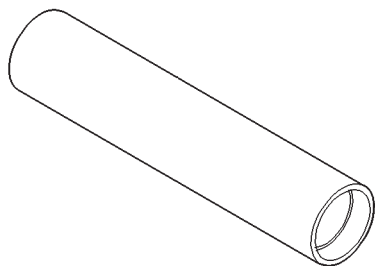

Installer 6052

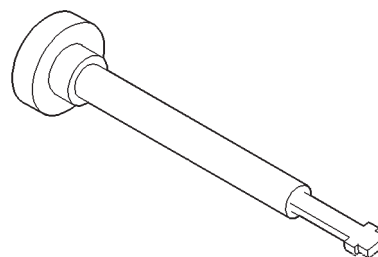

Remover/Installer 6302

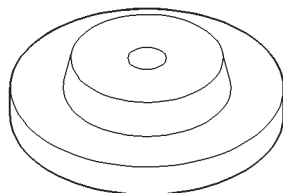

Disk 6057

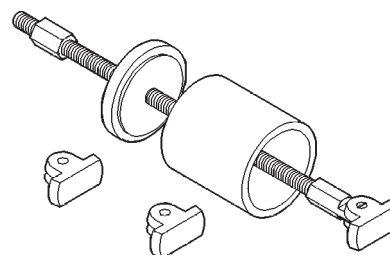

Remover 6310

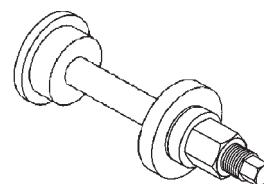

Installer 6494

SPECIAL TOOLS (Continued)

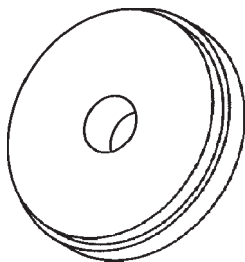

Remover 6495

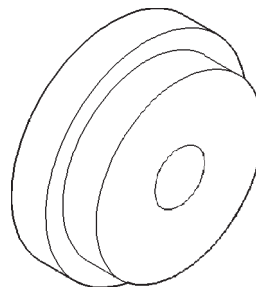

Installer 6522

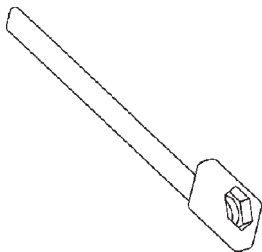

Wrench 6497

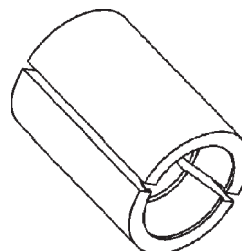

Puller Jaws 6545

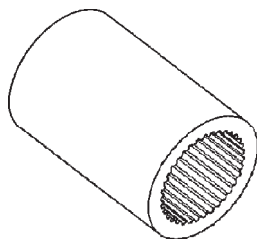

Wrench 6498

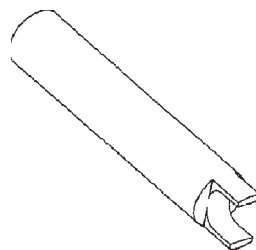

Turning Fork 6548

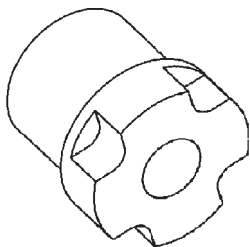

Remover 6502B

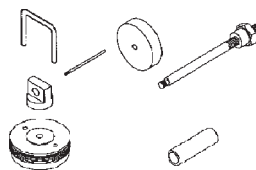

Pinion Gauge Tool Set 6549

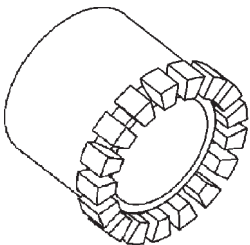

Wrench 6503

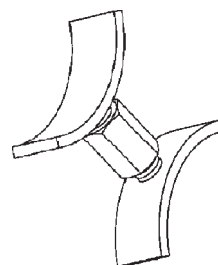

Remover 6550

SPECIAL TOOLS (Continued)

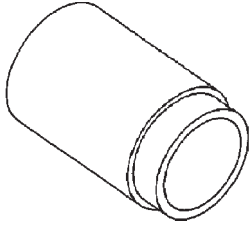

Installer 6558

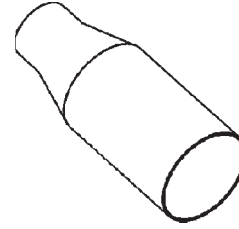

Seal Protector 6591

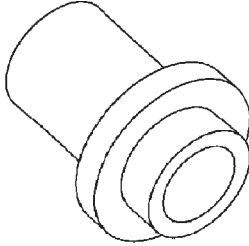

Installer 6560

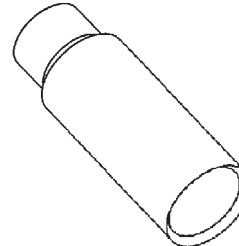

Seal Protector 6592

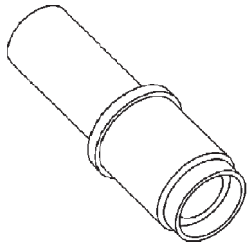

Seal Installer 6567A

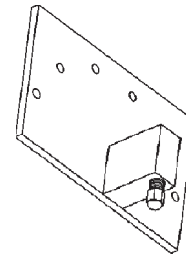

Fixture 6595

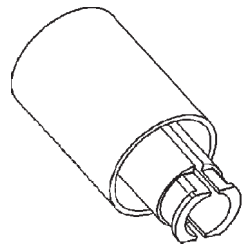

Remover 6577

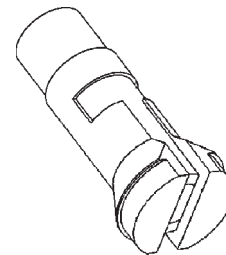

Remover 6596

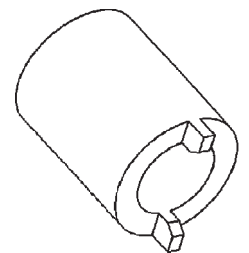

Staking Tool 6589

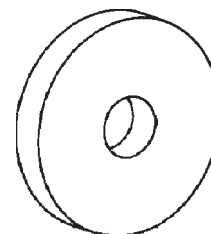

Remover 6597

SPECIAL TOOLS (Continued)

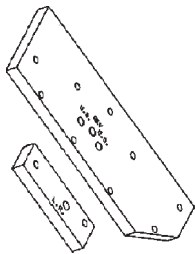
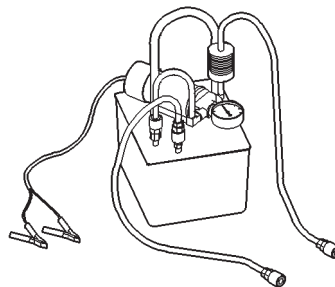
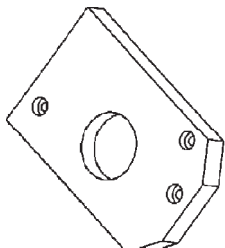

Plate Set 6599



Cooler Flusher 6906



Support Plate 6618A

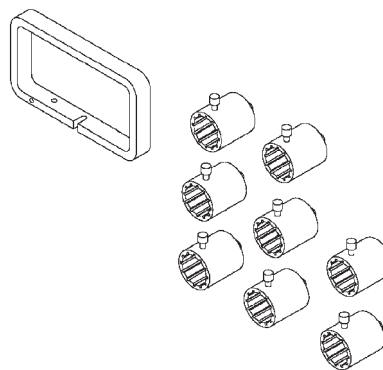

End Play Set 8266

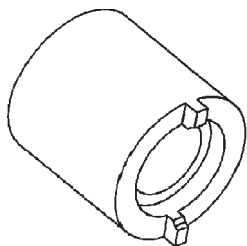

Staking Tool 6639

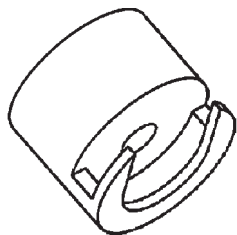

Remover 6669

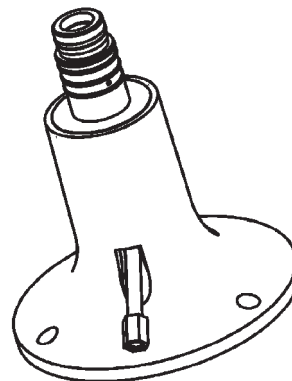

Pressure Fixture 8391

