

# SECTION **AT**

## AUTOMATIC TRANSMISSION

A  
B  
**AT**

### CONTENTS

<b>INDEX FOR DTC</b> .....	<b>5</b>	How To Perform Trouble Diagnosis For Quick and	F
Alphabetical Index .....	5	Accurate Repair .....	41
DTC No. Index .....	6	A/T Electrical Parts Location .....	46
<b>PRECAUTIONS</b> .....	<b>7</b>	Circuit Diagram .....	48
Precautions for Supplemental Restraint System		Wiring Diagram — AT — .....	49
(SRS) "AIR BAG" and "SEAT BELT PRE-TEN-		Inspections Before Trouble Diagnosis .....	55
SIONER" .....	7	Check Before Engine is Started .....	59
Precautions for Battery Service .....	7	Check at Idle .....	59
Precautions for On Board Diagnostic (OBD) System		Cruise Test - Part 1 .....	61
of A/T and Engine .....	7	Cruise Test - Part 2 .....	63
Precautions .....	7	Cruise Test - Part 3 .....	64
Service Notice or Precautions .....	8	Vehicle Speed When Shifting Gears .....	65
Wiring Diagrams and Trouble Diagnosis .....	8	Vehicle Speed When Performing and Releasing	
<b>PREPARATION</b> .....	<b>9</b>	Complete Lock-up .....	65
Special Service Tools .....	9	Vehicle Speed When Performing and Releasing	
Commercial Service Tools .....	9	Slip Lock-up .....	65
<b>A/T FLUID</b> .....	<b>10</b>	Symptom Chart .....	65
Changing A/T Fluid .....	10	TCM Input/Output Signal Reference Values .....	74
Checking A/T Fluid .....	10	CONSULT-II .....	75
A/T Fluid Cooler Cleaning .....	11	Diagnostic Procedure Without CONSULT-II .....	87
<b>A/T CONTROL SYSTEM</b> .....	<b>15</b>	<b>DTC U1000 CAN COMMUNICATION LINE</b> .....	<b>89</b>
Cross-Sectional View .....	15	Description .....	89
Shift Mechanism .....	16	On Board Diagnosis Logic .....	89
TCM Function .....	27	Possible Cause .....	89
CAN Communication .....	28	DTC Confirmation Procedure .....	89
Input/Output Signal of TCM .....	28	Diagnostic Procedure .....	90
Line Pressure Control .....	29	<b>DTC P0615 START SIGNAL CIRCUIT</b> .....	<b>91</b>
Shift Control .....	30	Description .....	91
Lock-Up Control .....	31	On Board Diagnosis Logic .....	91
Engine Brake Control .....	33	Possible Cause .....	91
Control Valve .....	33	DTC Confirmation Procedure .....	91
<b>ON BOARD DIAGNOSTIC (OBD) SYSTEM</b> .....	<b>35</b>	Diagnostic Procedure .....	92
Introduction .....	35	<b>DTC P0705 PARK/NEUTRAL POSITION SWITCH..</b>	<b>94</b>
OBD-II Function for A/T System .....	35	Description .....	94
One or Two Trip Detection Logic of OBD-II .....	35	CONSULT-II Reference Value .....	94
OBD-II Diagnostic Trouble Code (DTC) .....	35	On Board Diagnosis Logic .....	94
Malfunction Indicator Lamp (MIL) .....	38	Possible Cause .....	94
<b>TROUBLE DIAGNOSIS</b> .....	<b>39</b>	DTC Confirmation Procedure .....	94
DTC Inspection Priority Chart .....	39	Diagnostic Procedure .....	95
Fail-Safe .....	39	<b>DTC P0720 VEHICLE SPEED SENSOR A/T (REV-</b>	

D  
E  
F  
G  
H  
I  
J  
K  
L  
M

<p><b>OLUTION SENSOR) ..... 96</b></p> <p style="padding-left: 20px;">Description ..... 96</p> <p style="padding-left: 20px;">CONSULT-II Reference Value ..... 96</p> <p style="padding-left: 20px;">On Board Diagnosis Logic ..... 96</p> <p style="padding-left: 20px;">Possible Cause ..... 96</p> <p style="padding-left: 20px;">DTC Confirmation Procedure ..... 96</p> <p style="padding-left: 20px;">Diagnostic Procedure ..... 97</p> <p><b>DTC P0725 ENGINE SPEED SIGNAL ..... 98</b></p> <p style="padding-left: 20px;">Description ..... 98</p> <p style="padding-left: 20px;">CONSULT-II Reference Value ..... 98</p> <p style="padding-left: 20px;">On Board Diagnosis Logic ..... 98</p> <p style="padding-left: 20px;">Possible Cause ..... 98</p> <p style="padding-left: 20px;">DTC Confirmation Procedure ..... 98</p> <p style="padding-left: 20px;">Diagnostic Procedure ..... 98</p> <p><b>DTC P0740 TORQUE CONVERTER CLUTCH SOLENOID VALVE ..... 100</b></p> <p style="padding-left: 20px;">Description ..... 100</p> <p style="padding-left: 20px;">CONSULT-II Reference Value ..... 100</p> <p style="padding-left: 20px;">On Board Diagnosis Logic ..... 100</p> <p style="padding-left: 20px;">Possible Cause ..... 100</p> <p style="padding-left: 20px;">DTC Confirmation Procedure ..... 100</p> <p style="padding-left: 20px;">Diagnostic Procedure ..... 101</p> <p><b>DTC P0744 A/T TCC S/V FUNCTION (LOCK-UP). 102</b></p> <p style="padding-left: 20px;">Description ..... 102</p> <p style="padding-left: 20px;">CONSULT-II Reference Value ..... 102</p> <p style="padding-left: 20px;">On Board Diagnosis Logic ..... 102</p> <p style="padding-left: 20px;">Possible Cause ..... 102</p> <p style="padding-left: 20px;">DTC Confirmation Procedure ..... 102</p> <p style="padding-left: 20px;">Diagnostic Procedure ..... 103</p> <p><b>DTC P0745 LINE PRESSURE SOLENOID VALVE 104</b></p> <p style="padding-left: 20px;">Description ..... 104</p> <p style="padding-left: 20px;">CONSULT-II Reference Value ..... 104</p> <p style="padding-left: 20px;">On Board Diagnosis Logic ..... 104</p> <p style="padding-left: 20px;">Possible Cause ..... 104</p> <p style="padding-left: 20px;">DTC Confirmation Procedure ..... 104</p> <p style="padding-left: 20px;">Diagnostic Procedure ..... 105</p> <p><b>DTC P1701 TRANSMISSION CONTROL MODULE (POWER SUPPLY) ..... 106</b></p> <p style="padding-left: 20px;">Description ..... 106</p> <p style="padding-left: 20px;">On Board Diagnosis Logic ..... 106</p> <p style="padding-left: 20px;">Possible Cause ..... 106</p> <p style="padding-left: 20px;">DTC Confirmation Procedure ..... 106</p> <p style="padding-left: 20px;">Diagnostic Procedure ..... 106</p> <p><b>DTC P1702 TRANSMISSION CONTROL MODULE (RAM) ..... 109</b></p> <p style="padding-left: 20px;">Description ..... 109</p> <p style="padding-left: 20px;">On Board Diagnosis Logic ..... 109</p> <p style="padding-left: 20px;">Possible Cause ..... 109</p> <p style="padding-left: 20px;">DTC Confirmation Procedure ..... 109</p> <p style="padding-left: 20px;">Diagnostic Procedure ..... 109</p> <p><b>DTC P1703 TRANSMISSION CONTROL MODULE (ROM) ..... 110</b></p> <p style="padding-left: 20px;">Description ..... 110</p> <p style="padding-left: 20px;">On Board Diagnosis Logic ..... 110</p> <p style="padding-left: 20px;">Possible Cause ..... 110</p> <p style="padding-left: 20px;">DTC Confirmation Procedure ..... 110</p> <p style="padding-left: 20px;">Diagnostic Procedure ..... 110</p> <p><b>DTC P1704 TRANSMISSION CONTROL MODULE (EEPROM) ..... 111</b></p>	<p style="padding-left: 20px;">Description ..... 111</p> <p style="padding-left: 20px;">On Board Diagnosis Logic ..... 111</p> <p style="padding-left: 20px;">Possible Cause ..... 111</p> <p style="padding-left: 20px;">DTC Confirmation Procedure ..... 111</p> <p style="padding-left: 20px;">Diagnostic Procedure ..... 111</p> <p><b>DTC P1705 THROTTLE POSITION SENSOR ..... 112</b></p> <p style="padding-left: 20px;">Description ..... 112</p> <p style="padding-left: 20px;">On Board Diagnosis Logic ..... 112</p> <p style="padding-left: 20px;">Possible Cause ..... 112</p> <p style="padding-left: 20px;">DTC Confirmation Procedure ..... 112</p> <p style="padding-left: 20px;">Diagnostic Procedure ..... 112</p> <p><b>DTC P1710 A/T FLUID TEMPERATURE SENSOR CIRCUIT ..... 114</b></p> <p style="padding-left: 20px;">Description ..... 114</p> <p style="padding-left: 20px;">CONSULT-II Reference Value ..... 114</p> <p style="padding-left: 20px;">On Board Diagnosis Logic ..... 114</p> <p style="padding-left: 20px;">Possible Cause ..... 114</p> <p style="padding-left: 20px;">DTC Confirmation Procedure ..... 114</p> <p style="padding-left: 20px;">Diagnostic Procedure ..... 115</p> <p><b>DTC P1716 TURBINE REVOLUTION SENSOR ... 116</b></p> <p style="padding-left: 20px;">Description ..... 116</p> <p style="padding-left: 20px;">CONSULT-II Reference Value ..... 116</p> <p style="padding-left: 20px;">On Board Diagnosis Logic ..... 116</p> <p style="padding-left: 20px;">Possible Cause ..... 116</p> <p style="padding-left: 20px;">DTC Confirmation Procedure ..... 116</p> <p style="padding-left: 20px;">Diagnostic Procedure ..... 117</p> <p><b>DTC P1721 VEHICLE SPEED SENSOR MTR ..... 118</b></p> <p style="padding-left: 20px;">Description ..... 118</p> <p style="padding-left: 20px;">CONSULT-II Reference Value ..... 118</p> <p style="padding-left: 20px;">On Board Diagnosis Logic ..... 118</p> <p style="padding-left: 20px;">Possible Cause ..... 118</p> <p style="padding-left: 20px;">DTC Confirmation Procedure ..... 118</p> <p style="padding-left: 20px;">Diagnostic Procedure ..... 119</p> <p><b>DTC P1730 A/T INTERLOCK ..... 120</b></p> <p style="padding-left: 20px;">Description ..... 120</p> <p style="padding-left: 20px;">On Board Diagnosis Logic ..... 120</p> <p style="padding-left: 20px;">Possible Cause ..... 120</p> <p style="padding-left: 20px;">DTC Confirmation Procedure ..... 120</p> <p style="padding-left: 20px;">Judgement of A/T Interlock ..... 120</p> <p style="padding-left: 20px;">Diagnostic Procedure ..... 122</p> <p><b>DTC P1731 A/T 1ST ENGINE BRAKING ..... 123</b></p> <p style="padding-left: 20px;">Description ..... 123</p> <p style="padding-left: 20px;">CONSULT-II Reference Value ..... 123</p> <p style="padding-left: 20px;">On Board Diagnosis Logic ..... 123</p> <p style="padding-left: 20px;">Possible Cause ..... 123</p> <p style="padding-left: 20px;">DTC Confirmation Procedure ..... 123</p> <p style="padding-left: 20px;">Diagnostic Procedure ..... 124</p> <p><b>DTC P1752 INPUT CLUTCH SOLENOID VALVE .125</b></p> <p style="padding-left: 20px;">Description ..... 125</p> <p style="padding-left: 20px;">CONSULT-II Reference Value ..... 125</p> <p style="padding-left: 20px;">On Board Diagnosis Logic ..... 125</p> <p style="padding-left: 20px;">Possible Cause ..... 125</p> <p style="padding-left: 20px;">DTC Confirmation Procedure ..... 125</p> <p style="padding-left: 20px;">Diagnostic Procedure ..... 126</p> <p><b>DTC P1754 INPUT CLUTCH SOLENOID VALVE FUNCTION ..... 127</b></p> <p style="padding-left: 20px;">Description ..... 127</p> <p style="padding-left: 20px;">CONSULT-II Reference Value ..... 127</p> <p style="padding-left: 20px;">On Board Diagnosis Logic ..... 127</p>
---	--

<p>Possible Cause ..... 127</p> <p>DTC Confirmation Procedure ..... 127</p> <p>Diagnostic Procedure ..... 128</p> <p><b>DTC P1757 FRONT BRAKE SOLENOID VALVE . 129</b></p> <p>    Description ..... 129</p> <p>    CONSULT-II Reference Value ..... 129</p> <p>    On Board Diagnosis Logic ..... 129</p> <p>    Possible Cause ..... 129</p> <p>    DTC Confirmation Procedure ..... 129</p> <p>    Diagnostic Procedure ..... 130</p> <p><b>DTC P1759 FRONT BRAKE SOLENOID VALVE FUNCTION ..... 131</b></p> <p>    Description ..... 131</p> <p>    CONSULT-II Reference Value ..... 131</p> <p>    On Board Diagnosis Logic ..... 131</p> <p>    Possible Cause ..... 131</p> <p>    DTC Confirmation Procedure ..... 131</p> <p>    Diagnostic Procedure ..... 132</p> <p><b>DTC P1762 DIRECT CLUTCH SOLENOID VALVE 133</b></p> <p>    Description ..... 133</p> <p>    CONSULT-II Reference Value ..... 133</p> <p>    On Board Diagnosis Logic ..... 133</p> <p>    Possible Cause ..... 133</p> <p>    DTC Confirmation Procedure ..... 133</p> <p>    Diagnostic Procedure ..... 134</p> <p><b>DTC P1764 DIRECT CLUTCH SOLENOID VALVE FUNCTION ..... 135</b></p> <p>    Description ..... 135</p> <p>    CONSULT-II Reference Value ..... 135</p> <p>    On Board Diagnosis Logic ..... 135</p> <p>    Possible Cause ..... 135</p> <p>    DTC Confirmation Procedure ..... 135</p> <p>    Diagnostic Procedure ..... 136</p> <p><b>DTC P1767 HIGH AND LOW REVERSE CLUTCH SOLENOID VALVE ..... 137</b></p> <p>    Description ..... 137</p> <p>    CONSULT-II Reference Value ..... 137</p> <p>    On Board Diagnosis Logic ..... 137</p> <p>    Possible Cause ..... 137</p> <p>    DTC Confirmation Procedure ..... 137</p> <p>    Diagnostic Procedure ..... 138</p> <p><b>DTC P1769 HIGH AND LOW REVERSE CLUTCH SOLENOID VALVE FUNCTION ..... 139</b></p> <p>    Description ..... 139</p> <p>    CONSULT-II Reference Value ..... 139</p> <p>    On Board Diagnosis Logic ..... 139</p> <p>    Possible Cause ..... 139</p> <p>    DTC Confirmation Procedure ..... 139</p> <p>    Diagnostic Procedure ..... 140</p> <p><b>DTC P1772 LOW COAST BRAKE SOLENOID VALVE ..... 141</b></p> <p>    Description ..... 141</p> <p>    CONSULT-II Reference Value ..... 141</p> <p>    On Board Diagnosis Logic ..... 141</p> <p>    Possible Cause ..... 141</p> <p>    DTC Confirmation Procedure ..... 141</p> <p>    Diagnostic Procedure ..... 142</p> <p><b>DTC P1774 LOW COAST BRAKE SOLENOID VALVE FUNCTION ..... 143</b></p>	<p>Description ..... 143</p> <p>CONSULT-II Reference Value ..... 143</p> <p>On Board Diagnosis Logic ..... 143</p> <p>Possible Cause ..... 143</p> <p>DTC Confirmation Procedure ..... 143</p> <p>Diagnostic Procedure ..... 144</p> <p><b>DTC P1815 MANUAL MODE SWITCH ..... 145</b></p> <p>    Description ..... 145</p> <p>    CONSULT-II Reference Value in Data Monitor Mode ..... 145</p> <p>    On Board Diagnosis Logic ..... 145</p> <p>    Possible Cause ..... 145</p> <p>    DTC Confirmation Procedure ..... 145</p> <p>    Diagnostic Procedure ..... 146</p> <p>    Component Inspection ..... 147</p> <p>    Position Indicator Lamp ..... 147</p> <p><b>DTC P1841 ATF PRESSURE SWITCH 1 ..... 149</b></p> <p>    Description ..... 149</p> <p>    CONSULT-II Reference Value ..... 149</p> <p>    On Board Diagnosis Logic ..... 149</p> <p>    Possible Cause ..... 149</p> <p>    DTC Confirmation Procedure ..... 149</p> <p>    Diagnostic Procedure ..... 150</p> <p><b>DTC P1843 ATF PRESSURE SWITCH 3 ..... 151</b></p> <p>    Description ..... 151</p> <p>    CONSULT-II Reference Value ..... 151</p> <p>    On Board Diagnosis Logic ..... 151</p> <p>    Possible Cause ..... 151</p> <p>    DTC Confirmation Procedure ..... 151</p> <p>    Diagnostic Procedure ..... 152</p> <p><b>DTC P1845 ATF PRESSURE SWITCH 5 ..... 153</b></p> <p>    Description ..... 153</p> <p>    CONSULT-II Reference Value ..... 153</p> <p>    On Board Diagnosis Logic ..... 153</p> <p>    Possible Cause ..... 153</p> <p>    DTC Confirmation Procedure ..... 153</p> <p>    Diagnostic Procedure ..... 154</p> <p><b>DTC P1846 ATF PRESSURE SWITCH 6 ..... 155</b></p> <p>    Description ..... 155</p> <p>    CONSULT-II Reference Value ..... 155</p> <p>    On Board Diagnosis Logic ..... 155</p> <p>    Possible Cause ..... 155</p> <p>    DTC Confirmation Procedure ..... 155</p> <p>    Diagnostic Procedure ..... 156</p> <p><b>CLOSED THROTTLE POSITION AND WIDE OPEN THROTTLE POSITION CIRCUIT ..... 157</b></p> <p>    Diagnostic Procedure ..... 157</p> <p><b>BRAKE SIGNAL CIRCUIT ..... 158</b></p> <p>    Diagnostic Procedure ..... 158</p> <p><b>TROUBLE DIAGNOSIS FOR SYMPTOMS ..... 159</b></p> <p>    A/T CHECK Indicator Lamp Does Not Come On . 159</p> <p>    Engine Cannot Be Started In “P” or “N” Position . 160</p> <p>    In “P” Position, Vehicle Moves When Pushed .... 161</p> <p>    In “N” Position, Vehicle Moves ..... 162</p> <p>    Large Shock (“N” to “D” Position) ..... 163</p> <p>    Vehicle Does Not Creep Backward In “R” Position 164</p> <p>    Vehicle Does Not Creep Forward In “D” Position . 165</p> <p>    Vehicle Cannot Be Started From D1 ..... 166</p> <p>    A/T Does Not Shift: D1 → D2 ..... 167</p>
--	--

A  
B  
AT  
D  
E  
F  
G  
H  
I  
J  
K  
L  
M

---

A/T Does Not Shift: D2 → D3 .....	168	Wiring Diagram — AT — SHIFT .....	185
A/T Does Not Shift: D3 → D4 .....	169	Diagnostic Procedure .....	186
A/T Does Not Shift: D4 → D5 .....	170	<b>KEY INTERLOCK CABLE</b> .....	<b>188</b>
A/T Does Not Perform Lock-up .....	172	Components .....	188
A/T Does Not Hold Lock-up Condition .....	173	Removal .....	189
Lock-up Is Not Released .....	173	Installation .....	190
Engine Speed Does Not Return To Idle .....	174	<b>AIR BREATHER HOSE</b> .....	<b>191</b>
Cannot Be changed to Manual Mode .....	175	Removal and Installation .....	191
A/T Does Not Shift: 5th gear → 4th gear .....	175	<b>TRANSMISSION ASSEMBLY</b> .....	<b>192</b>
A/T Does Not Shift: 4th gear → 3rd gear .....	176	Removal and Installation .....	192
A/T Does Not Shift: 3rd gear → 2nd gear .....	177	<b>SERVICE DATA AND SPECIFICATIONS (SDS)</b> ...	<b>195</b>
A/T Does Not Shift: 2nd gear → 1st gear .....	178	General Specifications .....	195
Vehicle Does Not Decelerate By Engine Brake ...	179	Vehicle Speed When Shifting Gears .....	195
<b>SHIFT CONTROL SYSTEM</b> .....	<b>181</b>	Vehicle Speed When Performing and Releasing	
Control Device Removal and Installation .....	181	Complete Lock-up .....	195
Adjustment of A/T Position .....	182	Vehicle Speed When Performing and Releasing	
Checking of A/T Position .....	182	Slip Lock-up .....	195
<b>A/T SHIFT LOCK SYSTEM</b> .....	<b>184</b>	Stall Speed .....	195
Description .....	184	Line Pressure .....	196
Shift Lock System Electrical Parts Location .....	184		

## INDEX FOR DTC

## Alphabetical Index

## NOTE:

If DTC U1000 is displayed with other DTC, first perform the trouble diagnosis for DTC U1000. Refer to [AT-89](#).

Items (CONSULT-II screen terms)	DTC		Reference page
	OBD-II	Except OBD-II	
	CONSULT-II GST*1	CONSULT-II only "A/T"	
A/T 1ST E/BRAKING	—	P1731	<a href="#">AT-123</a>
ATF PRES SW 1/CIRC	—	P1841	<a href="#">AT-149</a>
ATF PRES SW 3/CIRC	—	P1843	<a href="#">AT-151</a>
ATF PRES SW 5/CIRC	—	P1845	<a href="#">AT-153</a>
ATF PRES SW 6/CIRC	—	P1846	<a href="#">AT-155</a>
A/T INTERLOCK	P1730	P1730	<a href="#">AT-120</a>
A/T TCC S/V FNCTN	P0744	P0744	<a href="#">AT-102</a>
ATF TEMP SEN/CIRC	P0710	P1710	<a href="#">AT-114</a>
CAN COMM CIRCUIT	U1000	U1000	<a href="#">AT-89</a>
D/C SOLENOID/CIRC	P1762	P1762	<a href="#">AT-133</a>
D/C SOLENOID FNCTN	P1764	P1764	<a href="#">AT-135</a>
ENGINE SPEED SIG	P0725	P0725	<a href="#">AT-98</a>
FR/B SOLENOID/CIRC	P1757	P1757	<a href="#">AT-129</a>
FR/B SOLENOID FNCT	P1759	P1759	<a href="#">AT-131</a>
HLR/C SOL/CIRC	P1767	P1767	<a href="#">AT-137</a>
HLR/C SOL FNCTN	P1769	P1769	<a href="#">AT-139</a>
I/C SOLENOID/CIRC	P1752	P1752	<a href="#">AT-125</a>
I/C SOLENOID FNCTN	P1754	P1754	<a href="#">AT-127</a>
L/PRESS SOL/CIRC	P0745	P0745	<a href="#">AT-104</a>
LC/B SOLENOID/CIRC	P1772	P1772	<a href="#">AT-141</a>
LC/B SOLENOID FNCT	P1774	P1774	<a href="#">AT-143</a>
MANU MODE SW/CIR	—	P1815	<a href="#">AT-145</a>
PNP SW/CIRC	P0705	P0705	<a href="#">AT-94</a>
STARTER RELAY/CIRC	—	P0615	<a href="#">AT-91</a>
TCC SOLENOID/CIRC	P0740	P0740	<a href="#">AT-100</a>
TCM-EEPROM	—	P1704	<a href="#">AT-111</a>
TCM-POWER SUPPLY	—	P1701	<a href="#">AT-106</a>
TCM-RAM	—	P1702	<a href="#">AT-109</a>
TCM-ROM	—	P1703	<a href="#">AT-110</a>
TP SEN/CIRC A/T	P1705	P1705	<a href="#">AT-112</a>
TURBINE REV S/CIRC	P1716	P1716	<a href="#">AT-116</a>
VEH SPD SE/CIR-MTR	—	P1721	<a href="#">AT-118</a>
VEH SPD SEN/CIR AT	P0720	P0720	<a href="#">AT-96</a>

\*1: These numbers are prescribed by SAE J2012.

## DTC No. Index

ACS000GS

### NOTE:

If DTC U1000 is displayed with other DTC, first perform the trouble diagnosis for DTC U1000. Refer to [AT-89](#).

DTC		Items (CONSULT-II screen terms)	Reference page
OBD-II CONSULT-II GST*1	Except OBD-II CONSULT-II only "A/T"		
—	P0615	STARTER RELAY/CIRC	<a href="#">AT-91</a>
P0705	P0705	PNP SW/CIRC	<a href="#">AT-94</a>
P0710	P1710	ATF TEMP SEN/CIRC	<a href="#">AT-114</a>
P0720	P0720	VEH SPD SEN/CIR AT	<a href="#">AT-96</a>
P0725	P0725	ENGINE SPEED SIG	<a href="#">AT-98</a>
P0740	P0740	TCC SOLENOID/CIRC	<a href="#">AT-100</a>
P0744	P0744	A/T TCC S/V FNCTN	<a href="#">AT-102</a>
P0745	P0745	L/PRESS SOL/CIRC	<a href="#">AT-104</a>
—	P1701	TCM-POWER SUPPLY	<a href="#">AT-106</a>
—	P1702	TCM-RAM	<a href="#">AT-109</a>
—	P1703	TCM-ROM	<a href="#">AT-110</a>
—	P1704	TCM-EEPROM	<a href="#">AT-111</a>
P1705	P1705	TP SEN/CIRC A/T	<a href="#">AT-112</a>
P1716	P1716	TURBINE REV S/CIRC	<a href="#">AT-116</a>
—	P1721	VEH SPD SE/CIR-MTR	<a href="#">AT-118</a>
P1730	P1730	A/T INTERLOCK	<a href="#">AT-120</a>
—	P1731	A/T 1ST E/BRAKING	<a href="#">AT-123</a>
P1752	P1752	I/C SOLENOID/CIRC	<a href="#">AT-125</a>
P1754	P1754	I/C SOLENOID FNCTN	<a href="#">AT-127</a>
P1757	P1757	FR/B SOLENOID/CIRC	<a href="#">AT-129</a>
P1759	P1759	FR/B SOLENOID FNCT	<a href="#">AT-131</a>
P1762	P1762	D/C SOLENOID/CIRC	<a href="#">AT-133</a>
P1764	P1764	D/C SOLENOID FNCTN	<a href="#">AT-135</a>
P1767	P1767	HLR/C SOL/CIRC	<a href="#">AT-137</a>
P1769	P1769	HLR/C SOL FNCTN	<a href="#">AT-139</a>
P1772	P1772	LC/B SOLENOID/CIRC	<a href="#">AT-141</a>
P1774	P1774	LC/B SOLENOID FNCT	<a href="#">AT-143</a>
—	P1815	MANU MODE SW/CIRC	<a href="#">AT-145</a>
—	P1841	ATF PRES SW 1/CIRC	<a href="#">AT-149</a>
—	P1843	ATF PRES SW 3/CIRC	<a href="#">AT-151</a>
—	P1845	ATF PRES SW 5/CIRC	<a href="#">AT-153</a>
—	P1846	ATF PRES SW 6/CIRC	<a href="#">AT-155</a>
U1000	U1000	CAN COMM CIRCUIT	<a href="#">AT-89</a>

\*1: These numbers are prescribed by SAE J2012.

## PRECAUTIONS

PFP:00001

### Precautions for Supplemental Restraint System (SRS) “AIR BAG” and “SEAT BELT PRE-TENSIONER”

ACS004LU

The Supplemental Restraint System such as “AIR BAG” and “SEAT BELT PRE-TENSIONER”, used along with a front seat belt, helps to reduce the risk or severity of injury to the driver and front passenger for certain types of collision. This system includes seat belt switch inputs and dual stage front air bag modules. The SRS system uses the seat belt switches to determine the front air bag deployment, and may only deploy one front air bag, depending on the severity of a collision and whether the front occupants are belted or unbelted. Information necessary to service the system safely is included in the SRS and SB section of this Service Manual.

#### **WARNING:**

- To avoid rendering the SRS inoperative, which could increase the risk of personal injury or death in the event of a collision which would result in air bag inflation, all maintenance must be performed by an authorized NISSAN/INFINITI dealer.
- Improper maintenance, including incorrect removal and installation of the SRS, can lead to personal injury caused by unintentional activation of the system. For removal of Spiral Cable and Air Bag Module, see the SRS section.
- Do not use electrical test equipment on any circuit related to the SRS unless instructed to in this Service Manual. SRS wiring harnesses can be identified by yellow and/or orange harnesses or harness connectors.

### Precautions for Battery Service

ACS001NN

This vehicle is equipped with the automatic window adjusting function. When a door is opened, the window automatically lowers slightly to avoid contact between the window and the roof. After the door is closed, the window will automatically raise slightly.

On vehicles equipped with the automatic window adjusting function, lower both the driver and front passenger side windows before disconnecting the battery cables. This will prevent interference between the side window and the roof when either door is opened/closed.

#### **CAUTION:**

After the battery cables are disconnected, do not open/close the driver and/or front passenger door with the window in the full up position. The automatic window adjusting function will not work and the roof may be damaged.

### Precautions for On Board Diagnostic (OBD) System of A/T and Engine

ACS000GU

The ECM has an on board diagnostic system. It will light up the malfunction indicator lamp (MIL) to warn the driver of a malfunction causing emission deterioration.

#### **CAUTION:**

- Be sure to turn the ignition switch “OFF” and disconnect the negative battery cable before any repair or inspection work. The open/short circuit of related switches, sensors, solenoid valves, etc. Will cause the MIL to light up.
- Be sure to connect and lock the connectors securely after work. A loose (unlocked) connector will cause the MIL to light up due to an open circuit. (Be sure the connector is free from water, grease, dirt, bent terminals, etc.)
- Be sure to route and secure the harnesses properly after work. Interference of the harness with a bracket, etc. May cause the MIL to light up due to a short circuit.
- Be sure to connect rubber tubes properly after work. A misconnected or disconnected rubber tube may cause the MIL to light up due to a malfunction of the EGR system or fuel injection system, etc.
- Be sure to erase the unnecessary malfunction information (repairs completed) from the TCM and ECM before returning the vehicle to the customer.

### Precautions

ACS000GW

#### **NOTE:**

If any malfunctions occur in the RE5R05A model transmission, replace the entire transmission assembly.

- Before connecting or disconnecting the TCM harness connector, turn ignition switch “OFF” and disconnect negative battery cable. Because battery voltage is applied to TCM even if ignition switch is turned “OFF”.

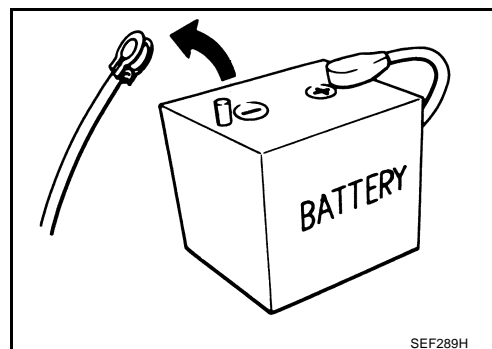

- After performing each TROUBLE DIAGNOSIS, perform “DTC (Diagnostic Trouble Code) CONFIRMATION PROCEDURE”.  
If the repair is completed the DTC should not be displayed in the “DTC CONFIRMATION PROCEDURE”.

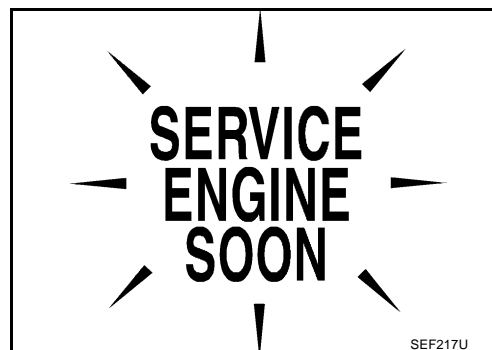

- Always use the specified brand of A/T fluid. Refer to [MA-11, "Fluids and Lubricants"](#) .
- Use paper rags not cloth rags during work.
- After replacing the A/T fluid, dispose of the waste oil using the methods prescribed by law, ordinance, etc.

### Service Notice or Precautions ATF COOLER SERVICE

ACS000GX

If A/T fluid contains frictional material (clutches, bands, etc.), or if an A/T is repaired, overhauled, or replaced, inspect and clean the A/T fluid cooler mounted in the radiator or replace the radiator. Flush cooler lines using cleaning solvent and compressed air after repair. For A/T fluid cooler cleaning procedure, refer to [AT-11, "A/T Fluid Cooler Cleaning"](#) . For radiator replacement, refer to [CO-12, "RADIATOR"](#) .

### OBD-II SELF-DIAGNOSIS

- A/T self-diagnosis is performed by the TCM in combination with the ECM. The results can be read through the blinking pattern of the A/T CHECK indicator or the malfunction indicator lamp (MIL). Refer to the table on [AT-77, "Self-diagnostic result test mode"](#) for the indicator used to display each self-diagnostic result.
- The self-diagnostic results indicated by the MIL are automatically stored in both the ECM and TCM memories.  
**Always perform the procedure on [AT-36, "HOW TO ERASE DTC"](#) to complete the repair and avoid unnecessary blinking of the MIL.**

For details of OBD-II, refer to [EC-46, "ON BOARD DIAGNOSTIC \(OBD\) SYSTEM"](#) .

- Certain systems and components, especially those related to OBD, may use the new style slide-locking type harness connector. For description and how to disconnect, refer to [PG-80, "HARNESS CONNECTOR"](#) .

### Wiring Diagrams and Trouble Diagnosis

ACS000GY

When you read wiring diagrams, refer to the following:

- [GI-15, "How to Read Wiring Diagrams"](#).
- [PG-4, "POWER SUPPLY ROUTING CIRCUIT"](#) for power distribution circuit.

When you perform trouble diagnosis, refer to the following:

- [GI-11, "How to Follow Trouble Diagnoses"](#).
- [GI-27, "How to Perform Efficient Diagnosis for an Electrical Incident"](#).



**PREPARATION**

PPF:00002

**Special Service Tools**

ACS000GZ

The actual shapes of Kent-Moore tools may differ from those of special service tools illustrated here.

Tool number (Kent-Moore No.) Tool name	Description
ST2505S001 (J34301-C) Oil pressure gauge set 1 ST25051001 ( — ) Oil pressure gauge 2 ST25052000 ( — ) Hose 3 ST25053000 ( — ) Joint pipe 4 ST25054000 ( — ) Adapter 5 ST25055000 ( — ) Adapter	Measuring line pressure
KV31103600 (J45674) Joint pipe adapter (With ST25054000)	Measuring line pressure

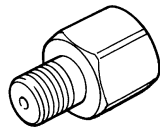
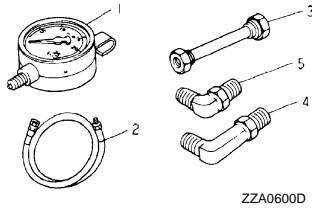

**Commercial Service Tools**

ACS000H0

Tool name	Description
Power tool	Loosening bolts and nuts

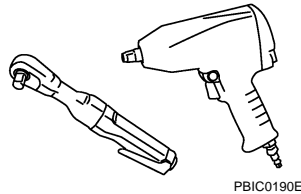

A  
B  
AT  
D  
E  
F  
G  
H  
I  
J  
K  
L  
M

## A/T FLUID

PFP:KLE40

### Changing A/T Fluid

ACS003S7

1. Warm up ATF.
2. Stop engine.
3. Remove the tightening bolt for A/T fluid level gauge.
4. Drain ATF from drain plug and refill with new ATF. Always refill same volume with drained fluid.
  - To replace the ATF, pour in new fluid at the charging pipe with the engine idling and at the same time drain the old fluid from the radiator cooler hose return side.
  - When the color of the fluid coming out is about the same as the color of the new fluid, the replacement is complete. The amount of new transmission fluid to use should be 30 to 50% of the stipulated amount.

**A/T fluid: Nissan Matic J ATF**

**Fluid capacity: 10.3 ℓ (10-7/8 US qt, 9-1/8 Imp qt)**

#### CAUTION:

- Use only Genuine Nissan Matic J ATF. Do not mix with other fluid.
- Using automatic transmission fluid other than Genuine Nissan Matic J ATF will cause deterioration in driveability and automatic transmission durability, and may damage the automatic transmission, which is not covered by the NISSAN new vehicle limited warranty.
- When filling ATF, take care not to scatter heat generating parts such as exhaust.

**Drain plug:**

 : 34 N·m (3.5 kg-m, 25 ft-lb)

5. Run engine at idle speed for 5 minutes.
6. Check fluid level and condition. Refer to [AT-10, "Checking A/T Fluid"](#) . If fluid is still dirty, repeat step 2. through 5.
7. Install the removed A/T fluid level gauge in the A/T fluid charging pipe.

**Level gauge bolt:**

 : 5.1 N·m (0.52 kg-m, 45 in-lb)

### Checking A/T Fluid

ACS003S8

1. Warm up engine.
2. Check for fluid leakage.
3. Remove the tightening bolt for A/T fluid level gauge.
4. Before driving, fluid level can be checked at fluid temperatures of 30 to 50°C (86 to 122°F) using "COLD" range on A/T fluid level gauge as follows.
  - a. Park vehicle on level surface and set parking brake.
  - b. Start engine and move selector lever through each gear position. Leave selector lever in "P" position.
  - c. Check fluid level with engine idling.
  - d. Remove A/T fluid level gauge and wipe clean with lint-free paper.

#### CAUTION:

**When wiping away the fluid level gauge, always use lint-free paper, not a cloth one.**

- e. Re-insert A/T fluid level gauge into charging pipe as far as it will go.

#### CAUTION:

**To check fluid level, insert the A/T fluid level gauge until the cap contacts the end of the A/T fluid charging pipe, with the gauge reversed from the normal attachment conditions.**

- f. Remove A/T fluid level gauge and note reading. If reading is at low side of range, add fluid to the A/T fluid charging pipe.

#### CAUTION:

**Do not overfill.**

5. Drive vehicle for approximately 5 minutes in urban areas.

6. Make the fluid temperature approximately 65°C (149°F).

**NOTE:**

Fluid level will be greatly affected by temperature as shown in figure. Therefore, be certain to perform operation while checking data with CONSULT-II.

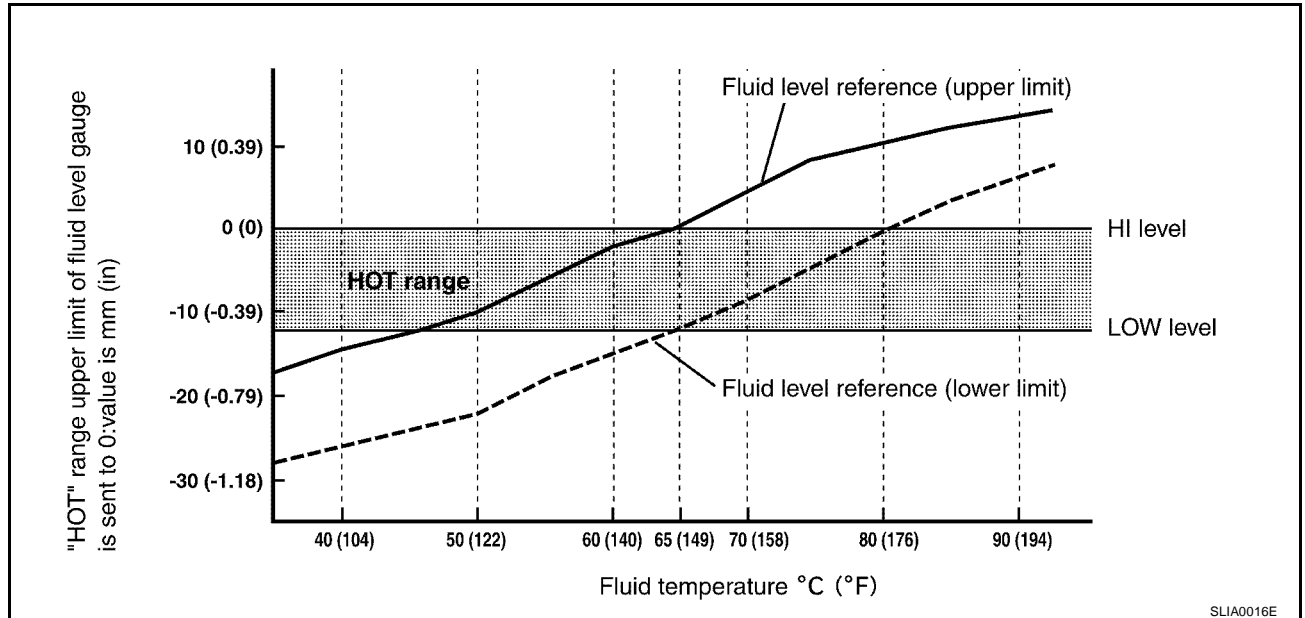

- Connect CONSULT-II to data link connector.
- Select "MAIN SIGNALS" in "DATA MONITOR" mode for "A/T" with CONSULT-II.
- Read out the value of "ATF TEMP 1".
- Re-check fluid level at fluid temperatures of approximately 65°C (149°F) using "HOT" range on A/T fluid level gauge.

**CAUTION:**

- When wiping away the fluid level gauge, always use lint-free paper, not a cloth one.
- To check fluid level, insert the A/T fluid level gauge until the cap contacts the end of the A/T fluid charging pipe, with the gauge reversed from the normal attachment conditions as shown.

- Check fluid condition.
  - If fluid is very dark or smells burned, refer to check operation of A/T. Flush cooling system after repair of A/T.
  - If ATF contains frictional material (clutches, bands, etc.), replace radiator and flush cooler line using cleaning solvent and compressed air after repair of A/T. Refer to [CO-12, "RADIATOR"](#) and [AT-11, "A/T Fluid Cooler Cleaning"](#).

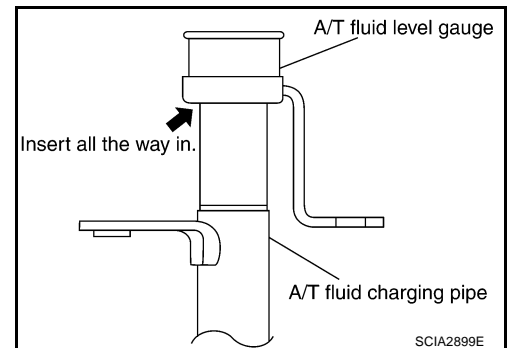

- Install the removed A/T fluid level gauge in the A/T fluid charging pipe.

**Level gauge bolt:**

 : 5.1N·m (0.52 kg·m, 45 in·lb)

## A/T Fluid Cooler Cleaning

ACS004LL

Whenever an automatic transmission is replaced, the A/T fluid cooler mounted in the radiator must be inspected and cleaned.

Metal debris and friction material, if present, can become trapped in the A/T fluid cooler. This debris can contaminate the newly serviced A/T or, in severe cases, can block or restrict the flow of A/T fluid. In either case, malfunction of the newly serviced A/T may result.

Debris, if present, may build up as A/T fluid enters the cooler inlet. It will be necessary to back flush the cooler through the cooler outlet in order to flush out any built up debris.

## A/T FLUID COOLER CLEANING PROCEDURE

1. Position an oil pan under the automatic transmission's inlet and outlet cooler hoses.
2. Identify the inlet and outlet fluid cooler hoses.
3. Disconnect the fluid cooler inlet and outlet rubber hoses from the steel cooler tubes or bypass valve.

### NOTE:

Replace the cooler hoses if rubber material from the hose remains on the tube fitting.

4. Allow any A/T fluid that remains in the cooler hoses to drain into the oil pan.

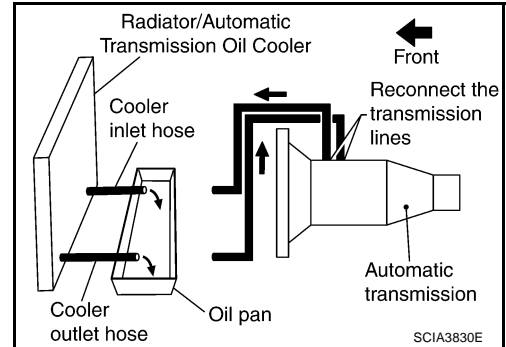

5. Insert the extension adapter hose of a can of Transmission Cooler Cleaner (Nissan P/N 999MP-AM006) into the cooler outlet hose.

### CAUTION:

- Wear safety glasses and rubber gloves when spraying the Transmission Cooler Cleaner.
- Spray cooler cleaner only with adequate ventilation.
- Avoid contact with eyes and skin.
- Do not breath vapors or spray mist.

6. Hold the hose and can as high as possible and spray Transmission Cooler Cleaner in a continuous stream into the cooler outlet hose until fluid flows out of the cooler inlet hose for 5 seconds.
7. Insert the tip of an air gun into the end of the cooler outlet hose.
8. Wrap a shop rag around the air gun tip and of the cooler outlet hose.

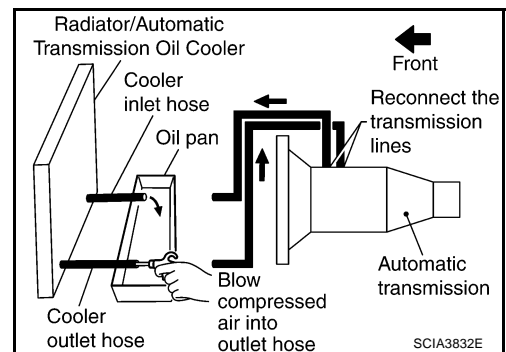
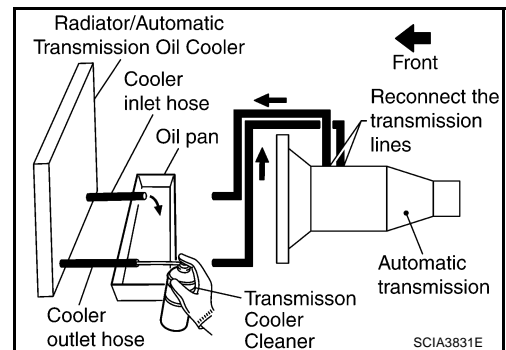

9. Blow compressed air regulated to 5 - 9 kg/cm<sup>2</sup> (70 - 130 psi) through the cooler outlet hose for 10 seconds to force out any remaining fluid.
10. Repeat steps 5 through 9 three additional times.
11. Position an oil pan under the banjo bolts that connect the fluid cooler steel lines to the transmission.
12. Remove the banjo bolts.
13. Flush each steel line from the cooler side back toward the transmission by spraying Transmission Cooler Cleaner in a continuous stream for 5 seconds.
14. Blow compressed air regulated to 5 - 9 kg/cm<sup>2</sup> (70 - 130 psi) through each steel line from the cooler side back toward the transmission for 10 seconds to force out any remaining fluid.
15. Ensure all debris is removed from the steel cooler lines.
16. Ensure all debris is removed from the banjo bolts and fittings.
17. Perform [AT-13, "A/T FLUID COOLER DIAGNOSIS PROCEDURE"](#).

**A/T FLUID COOLER DIAGNOSIS PROCEDURE**

**NOTE:**

Insufficient cleaning of the cooler inlet hose exterior may lead to inaccurate debris identification.

1. Position an oil pan under the automatic transmission's inlet and outlet cooler hoses.
2. Clean the exterior and tip of the cooler inlet hose.
3. Insert the extension adapter hose of a can of Transmission Cooler Cleaner (Nissan P/N 999MP-AM006) into the cooler outlet hose.

**CAUTION:**

- **Wear safety glasses and rubber gloves when spraying the Transmission Cooler Cleaner.**
- **Spray cooler cleaner only with adequate ventilation.**
- **Avoid contact with eyes and skin.**
- **Do not breath vapors or spray mist.**

4. Hold the hose and can as high as possible and spray Transmission Cooler Cleaner in a continuous stream into the cooler outlet hose until fluid flows out of the cooler inlet hose for 5 seconds.
5. Tie a common white, basket-type coffee filter to the end of the cooler inlet hose.

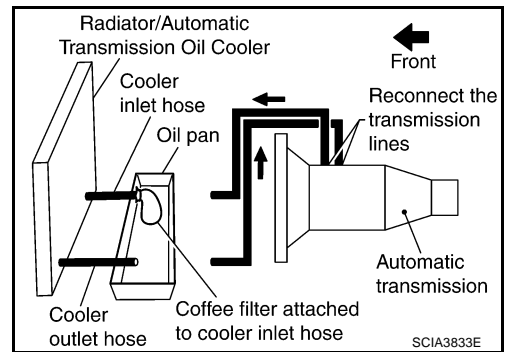
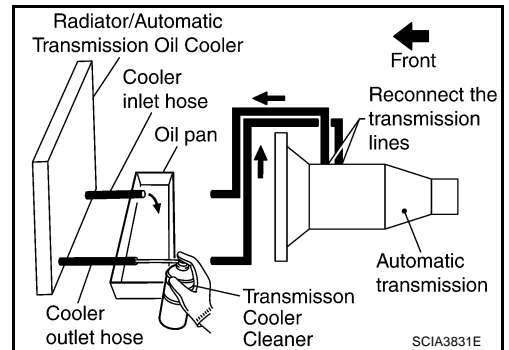

6. Insert the tip of an air gun into the end of the cooler outlet hose.
7. Wrap a shop rag around the air gun tip and end of cooler outlet hose.
8. Blow compressed air regulated to 5 - 9 kg/cm<sup>2</sup> (70 - 130 psi) through the cooler outlet hose to force any remaining A/T fluid into the coffee filter.
9. Remove the coffee filter from the end of the cooler inlet hose.
10. Perform [AT-13, "A/T FLUID COOLER INSPECTION PROCEDURE"](#).

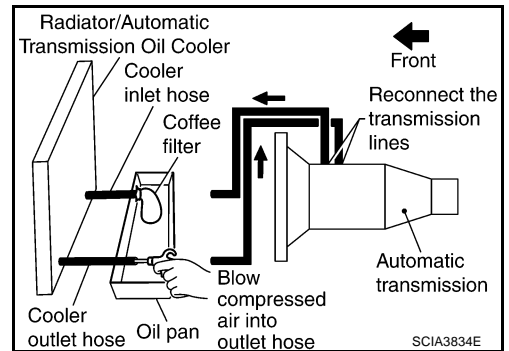

**A/T FLUID COOLER INSPECTION PROCEDURE**

1. Inspect the coffee filter for debris.
  - a. If small metal debris less than 1mm (0.040 in) in size or metal powder is found in the coffee filter, this is normal. If normal debris is found, the A/T fluid cooler/radiator can be re-used and the procedure is ended.

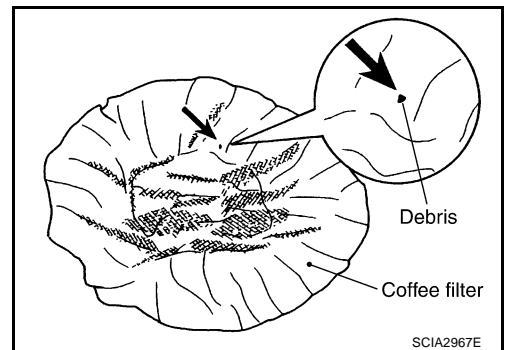

- b. If one or more pieces of debris are found that are over 1mm in size and/or peeled clutch facing material is found in the coffee filter, the fluid cooler is not serviceable. The A/T fluid cooler/radiator must be replaced and the inspection procedure is ended. Refer to [CO-12, "RADIATOR"](#) and [CO-15, "RADIATOR \(ALUMINUM TYPE\)"](#).

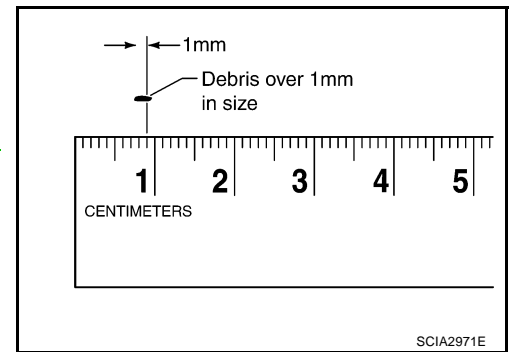

### A/T FLUID COOLER FINAL INSPECTION

After performing all procedures, ensure that all remaining oil is cleaned from all components.

**A/T CONTROL SYSTEM**  
**Cross-Sectional View**

PFP:31036

ACS000H3

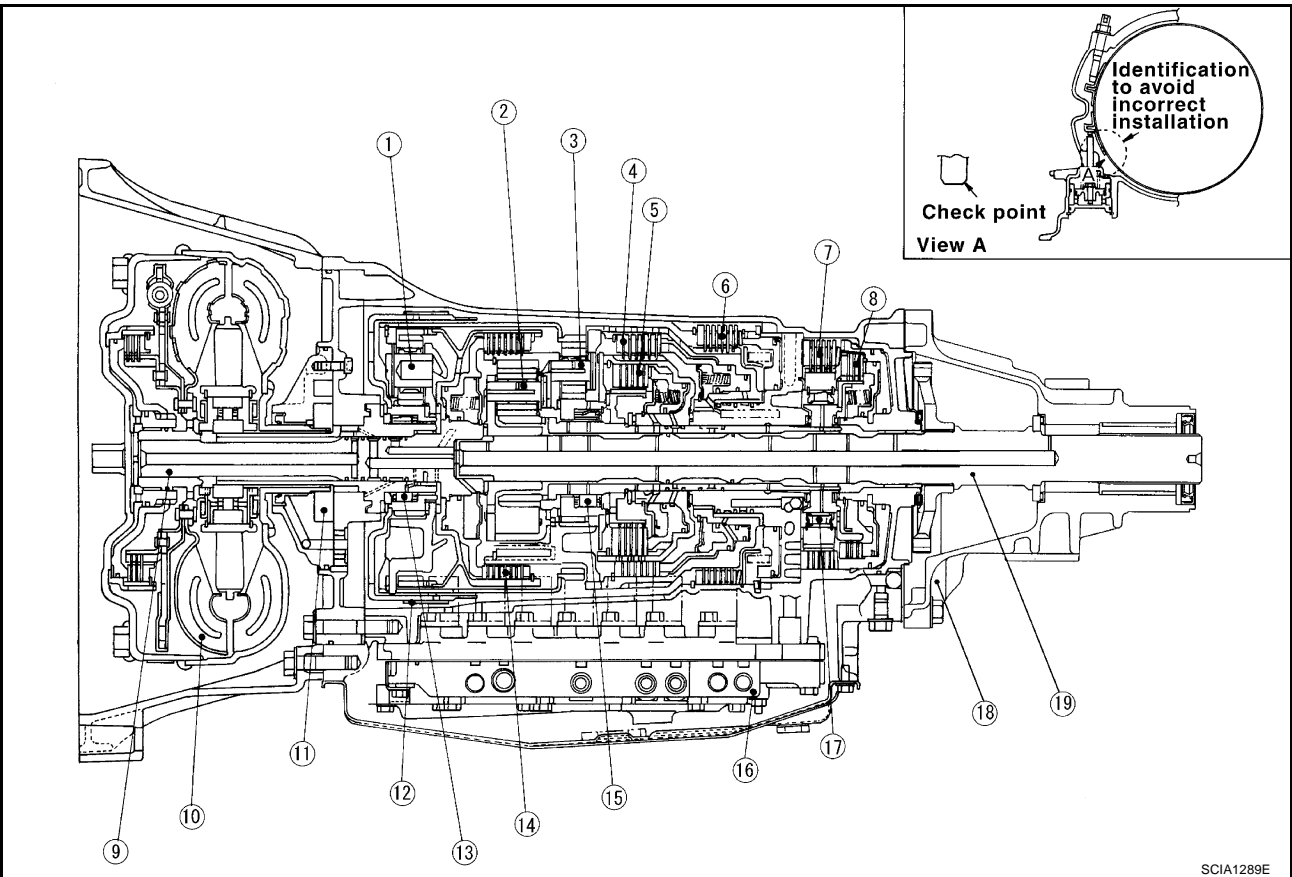

SCIA1289E

- |                            |                                |                        |
|----------------------------|--------------------------------|------------------------|
| 1. Front planetary gear    | 2. Mid planetary gear          | 3. Rear planetary gear |
| 4. Direct clutch           | 5. High and low reverse clutch | 6. Reverse brake       |
| 7. Forward brake           | 8. Low coast brake             | 9. Input shaft         |
| 10. Torque converter       | 11. Oil pump                   | 12. Front brake        |
| 13. 3rd one-way clutch     | 14. Input clutch               | 15. 1st one-way clutch |
| 16. Control valve with TCM | 17. Forward one-way clutch     | 18. Rear extension     |
| 19. Output shaft           |                                |                        |

A  
B  
AT  
D  
E  
F  
G  
H  
I  
J  
K  
L  
M

## Shift Mechanism

ACS000H4

The automatic transmission uses compact dual planetary gear systems to improve power-transmission efficiency, simplify construction and reduce weight. It also employs an optimum shift control and super wide gear ratios. They improve starting performance and acceleration during medium and high-speed operation.

### CONSTRUCTION

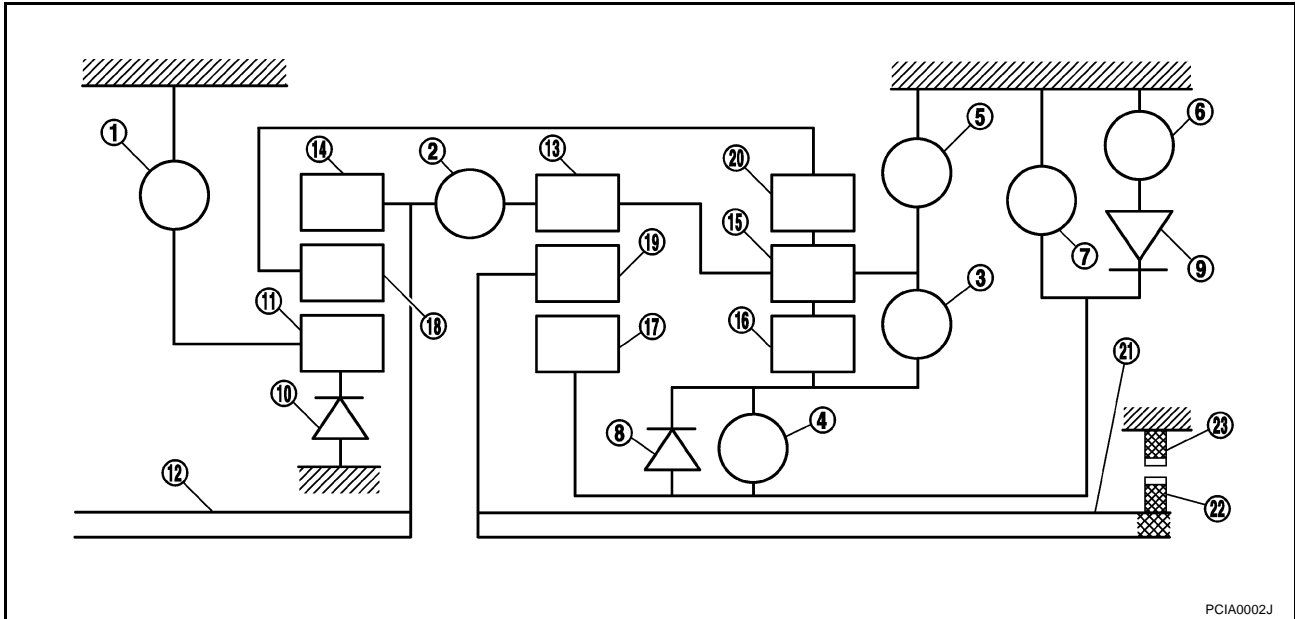

PCIA0002J

- |                                |                         |                           |
|--------------------------------|-------------------------|---------------------------|
| 1. Front brake                 | 2. Input clutch         | 3. Direct clutch          |
| 4. High and low reverse clutch | 5. Reverse brake        | 6. Forward brake          |
| 7. Low coast brake             | 8. 1st one-way clutch   | 9. Forward one-way clutch |
| 10. 3rd one-way clutch         | 11. Front sun gear      | 12. Input shaft           |
| 13. Mid internal gear          | 14. Front internal gear | 15. Rear carrier          |
| 16. Rear sun gear              | 17. Mid sun gear        | 18. Front carrier         |
| 19. Mid carrier                | 20. Rear internal gear  | 21. Output shaft          |
| 22. Parking gear               | 23. Parking pawl        |                           |

### FUNCTION OF CLUTCH AND BRAKE

Name of the Part	Abbreviation	Function
Front brake (1)	FR/B	Fastens the front sun gear (11).
Input clutch (2)	I/C	Connects the input shaft (12), the front internal gear (14) and the mid internal gear (13).
Direct clutch (3)	D/C	Connects the rear carrier (15) and the rear sun gear (16).
High and low reverse clutch (4)	H&LR/C	Connects the mid sun gear (17) and the rear sun gear (16).
Reverse brake (5)	R/B	Fastens the rear carrier (15).
Forward brake (6)	Fwd/B	Fastens the mid sun gear (17).
Low coast brake (7)	LC/B	Fastens the mid sun gear (17).
1st one-way clutch (8)	1st/OWC	Allows the rear sun gear (16) to turn freely forward relative to the mid sun gear (17) but fastens it for reverse rotation.
Forward one-way clutch (9)	Fwd/OWC	Allows the mid sun gear (17) to turn freely in the forward direction but fastens it for reverse rotation.
3rd one-way clutch (10)	3rd/OWC	Allows the front sun gear (11) to turn freely in the forward direction but fastens it for reverse rotation.



## CLUTCH AND BAND CHART

Shift position		I/C	H&LR/ C	D/C	R/B	Fr/B	LC/B	Fwd/B	1st OWC	Fwd OWC	3rd OWC	Remarks
P			△			△						PARK POSITION
R			○		○	○			◎		◎	REVERSE POSITION
N			△			△						NEUTRAL POSITION
D	1 st		△ *			△	△ **	○	◎	◎	◎	Automatic shift 1↔2↔3↔4↔5
	2 nd			○		△		○		◎	◎	
	3 rd		○	○		○		△	◇		◎	
	4 th	○	○	○				△	◇			
	5 th	○	○			○		△	◇		◇	
M5	5 th	○	○			○		△	◇		◇	Locks (held stationary) in 5th gear
M4	4 th	○	○	○				△	◇			Locks (held stationary) in 4th gear
M3	3 rd		○	○		○		△	◇		◎	Locks (held stationary) in 3th gear
M2	2 nd			○		○	○	○		◎	◎	Locks (held stationary) in 2th gear
M1	1 st		○			○	○	○	◎	◎	◎	Locks (held stationary) in 1th gear

- — Operates
- ◎ — Operates during "progressive" acceleration.
- ◇ — Operates and affects power transmission while coasting.
- △ — Line pressure is applied but does not affect power transmission.
- △ \* — Operates under conditions shown in illustration ①.
- △ \*\* — Operates under conditions shown in illustration ②. Delay control is applied during D (4,3,2,1) → N shift.

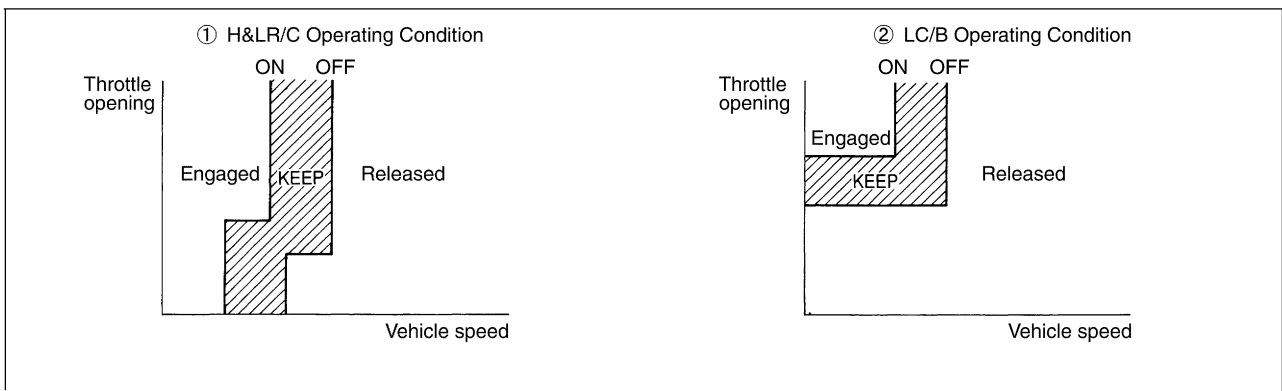

## POWER TRANSMISSION

### “N” position

Since both the forward brake and the reverse brake are released, torque from the input shaft drive is not transmitted to the output shaft.

### “P” position

- The same as for the “N” position, both the forward brake and the reverse brake are released, so torque from the input shaft drive is not transmitted to the output shaft.
- The parking pawl linked with the select lever meshes with the parking gear and fastens the output shaft mechanically.

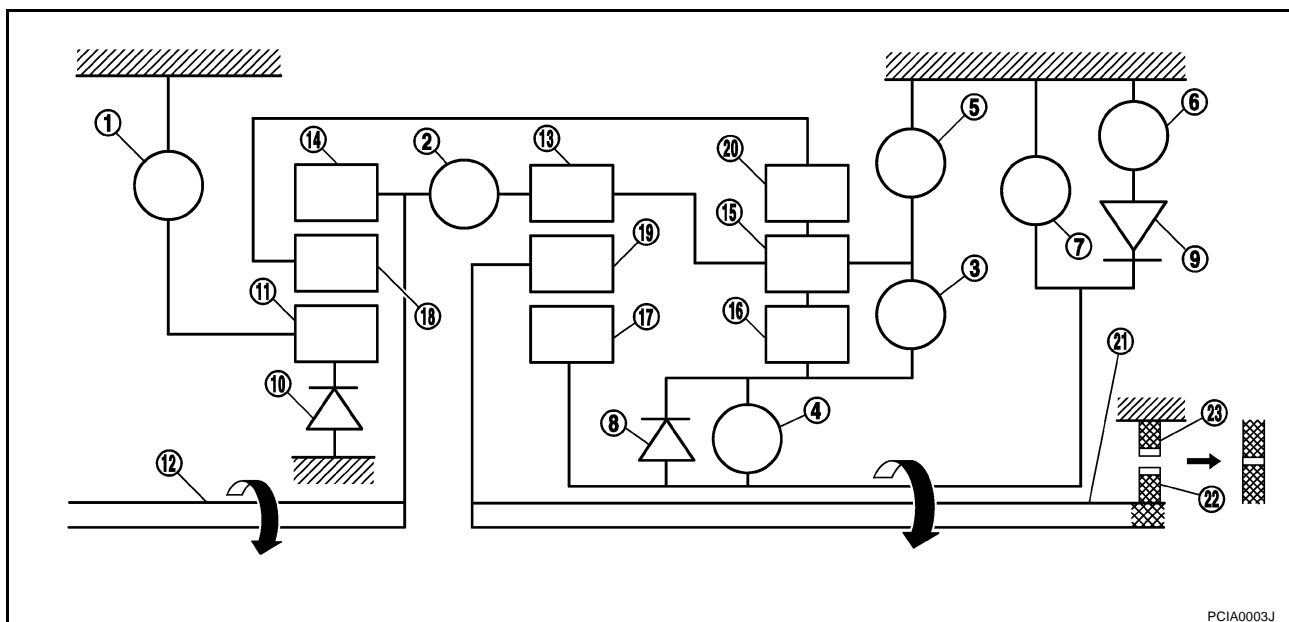

- |                                |                         |                           |
|--------------------------------|-------------------------|---------------------------|
| 1. Front brake                 | 2. Input clutch         | 3. Direct clutch          |
| 4. High and low reverse clutch | 5. Reverse brake        | 6. Forward brake          |
| 7. Low coast brake             | 8. 1st one-way clutch   | 9. Forward one-way clutch |
| 10. 3rd one-way clutch         | 11. Front sun gear      | 12. Input shaft           |
| 13. Mid internal gear          | 14. Front internal gear | 15. Rear carrier          |
| 16. Rear sun gear              | 17. Mid sun gear        | 18. Front carrier         |
| 19. Mid carrier                | 20. Rear internal gear  | 21. Output shaft          |
| 22. Parking gear               | 23. Parking pawl        |                           |

**“D1 ” position**

- The forward brake and the forward one-way clutch regulate reverse rotation of the mid sun gear.
- The first one-way clutch regulates reverse rotation of the rear sun gear.
- The third one-way clutch regulates reverse rotation of the front sun gear.
- During deceleration, the mid sun gear turns forward, so the forward one-way clutch idles and the engine brake is not activated.

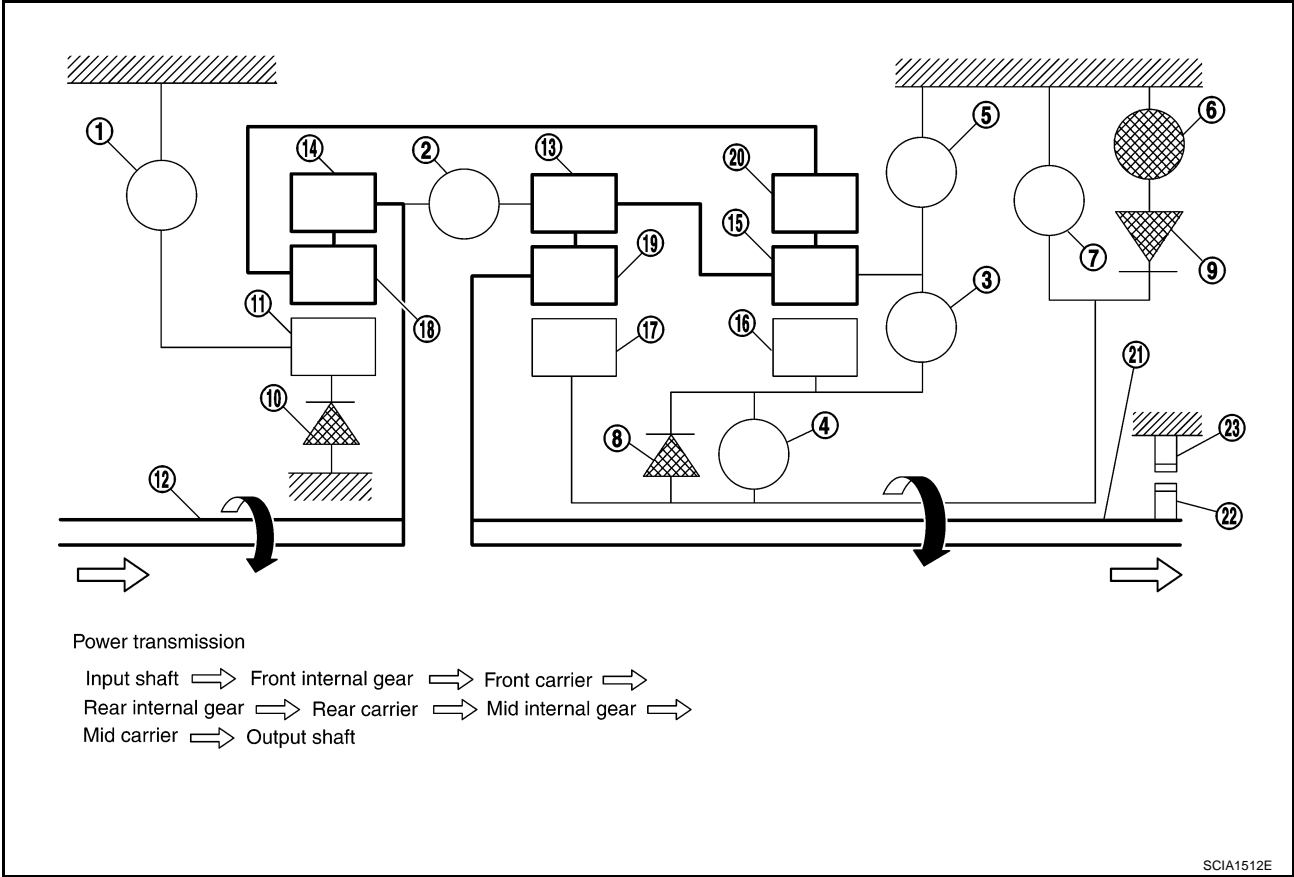

- |                                |                         |                           |
|--------------------------------|-------------------------|---------------------------|
| 1. Front brake                 | 2. Input clutch         | 3. Direct clutch          |
| 4. High and low reverse clutch | 5. Reverse brake        | 6. Forward brake          |
| 7. Low coast brake             | 8. 1st one-way clutch   | 9. Forward one-way clutch |
| 10. 3rd one-way clutch         | 11. Front sun gear      | 12. Input shaft           |
| 13. Mid internal gear          | 14. Front internal gear | 15. Rear carrier          |
| 16. Rear sun gear              | 17. Mid sun gear        | 18. Front carrier         |
| 19. Mid carrier                | 20. Rear internal gear  | 21. Output shaft          |
| 22. Parking gear               | 23. Parking pawl        |                           |

**“M1” position**

- The front brake fastens the front sun gear.
- The forward brake and the forward one-way clutch regulate reverse rotation of the mid sun gear.
- High and low reverse clutch connects the rear sun gear and the mid sun gear.
- The low coast brake fastens the mid sun gear.
- During deceleration, the low coast brake regulates forward rotation of the mid sun gear and the engine brake functions.

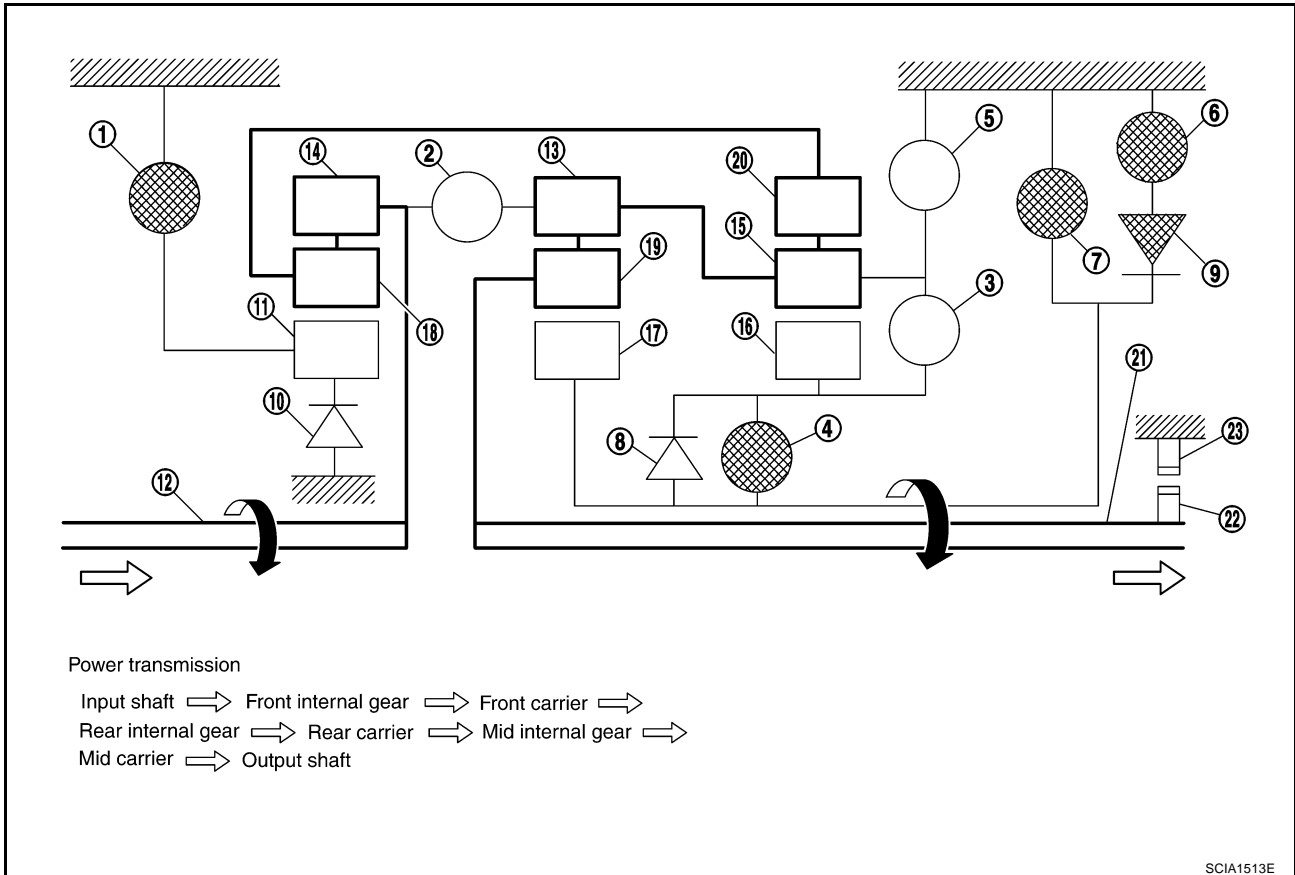

- |                                |                         |                           |
|--------------------------------|-------------------------|---------------------------|
| 1. Front brake                 | 2. Input clutch         | 3. Direct clutch          |
| 4. High and low reverse clutch | 5. Reverse brake        | 6. Forward brake          |
| 7. Low coast brake             | 8. 1st one-way clutch   | 9. Forward one-way clutch |
| 10. 3rd one-way clutch         | 11. Front sun gear      | 12. Input shaft           |
| 13. Mid internal gear          | 14. Front internal gear | 15. Rear carrier          |
| 16. Rear sun gear              | 17. Mid sun gear        | 18. Front carrier         |
| 19. Mid carrier                | 20. Rear internal gear  | 21. Output shaft          |
| 22. Parking gear               | 23. Parking pawl        |                           |

**“D2 ” position**

- The forward brake and the forward one-way clutch regulate reverse rotation of the mid sun gear.
- The third one-way clutch regulates reverse rotation of the front sun gear.
- The direct clutch is coupled, and the rear carrier and rear sun gear are connected.
- During deceleration, the mid sun gear turns forward, so the forward one-way clutch idles and engine brake is not activated.

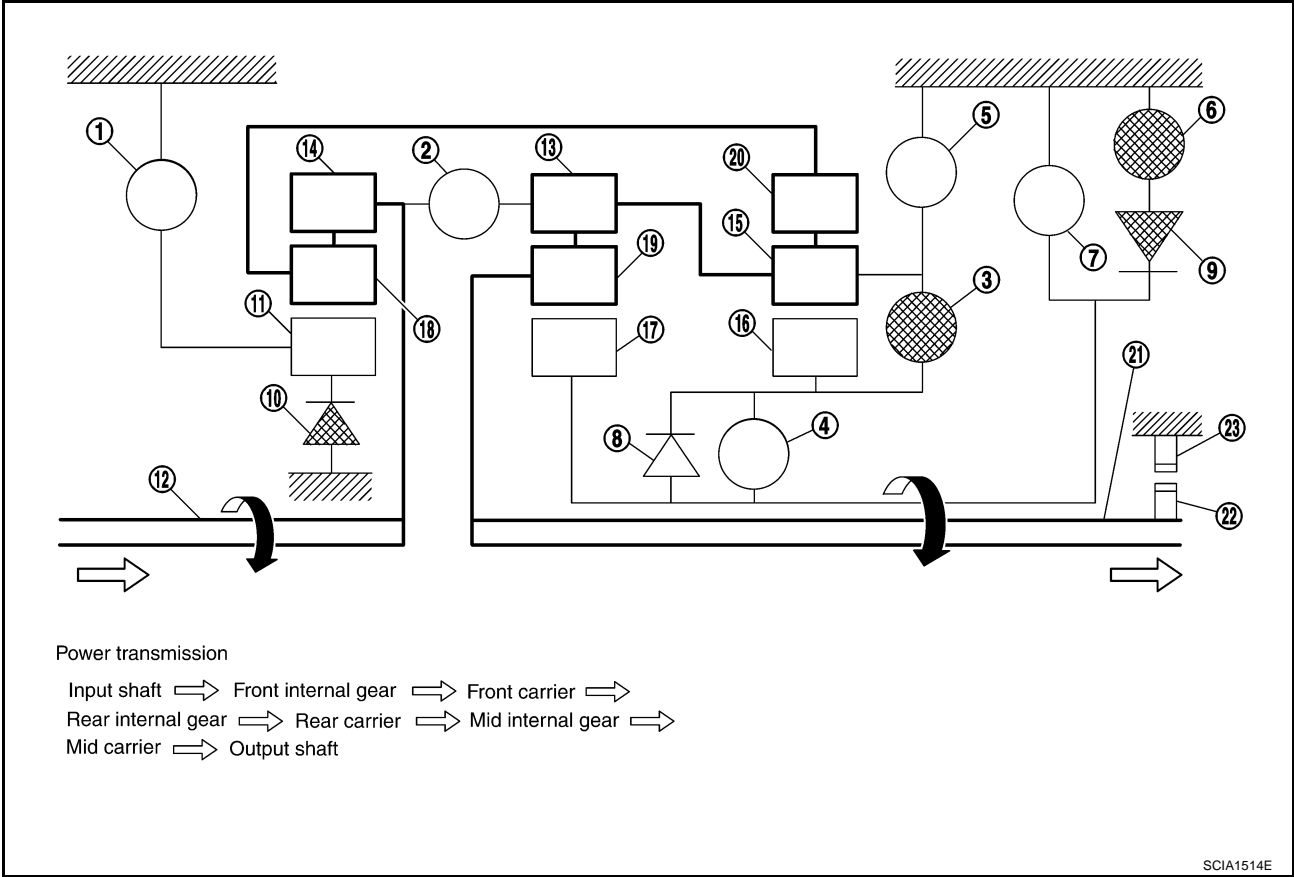

- |                                |                         |                           |
|--------------------------------|-------------------------|---------------------------|
| 1. Front brake                 | 2. Input clutch         | 3. Direct clutch          |
| 4. High and low reverse clutch | 5. Reverse brake        | 6. Forward brake          |
| 7. Low coast brake             | 8. 1st one-way clutch   | 9. Forward one-way clutch |
| 10. 3rd one-way clutch         | 11. Front sun gear      | 12. Input shaft           |
| 13. Mid internal gear          | 14. Front internal gear | 15. Rear carrier          |
| 16. Rear sun gear              | 17. Mid sun gear        | 18. Front carrier         |
| 19. Mid carrier                | 20. Rear internal gear  | 21. Output shaft          |
| 22. Parking gear               | 23. Parking pawl        |                           |

A  
B  
AT  
D  
E  
F  
G  
H  
I  
J  
K  
L  
M

## “M2” position

- The front brake fastens the front sun gear.
- The forward brake and the forward one-way clutch regulate reverse rotation of the mid sun gear.
- The direct clutch is coupled, and the rear carrier and rear sun gear are connected.
- The low coast brake fastens the mid sun gear.
- During deceleration, the low coast brake regulates forward rotation of the mid sun gear and the engine brake functions.

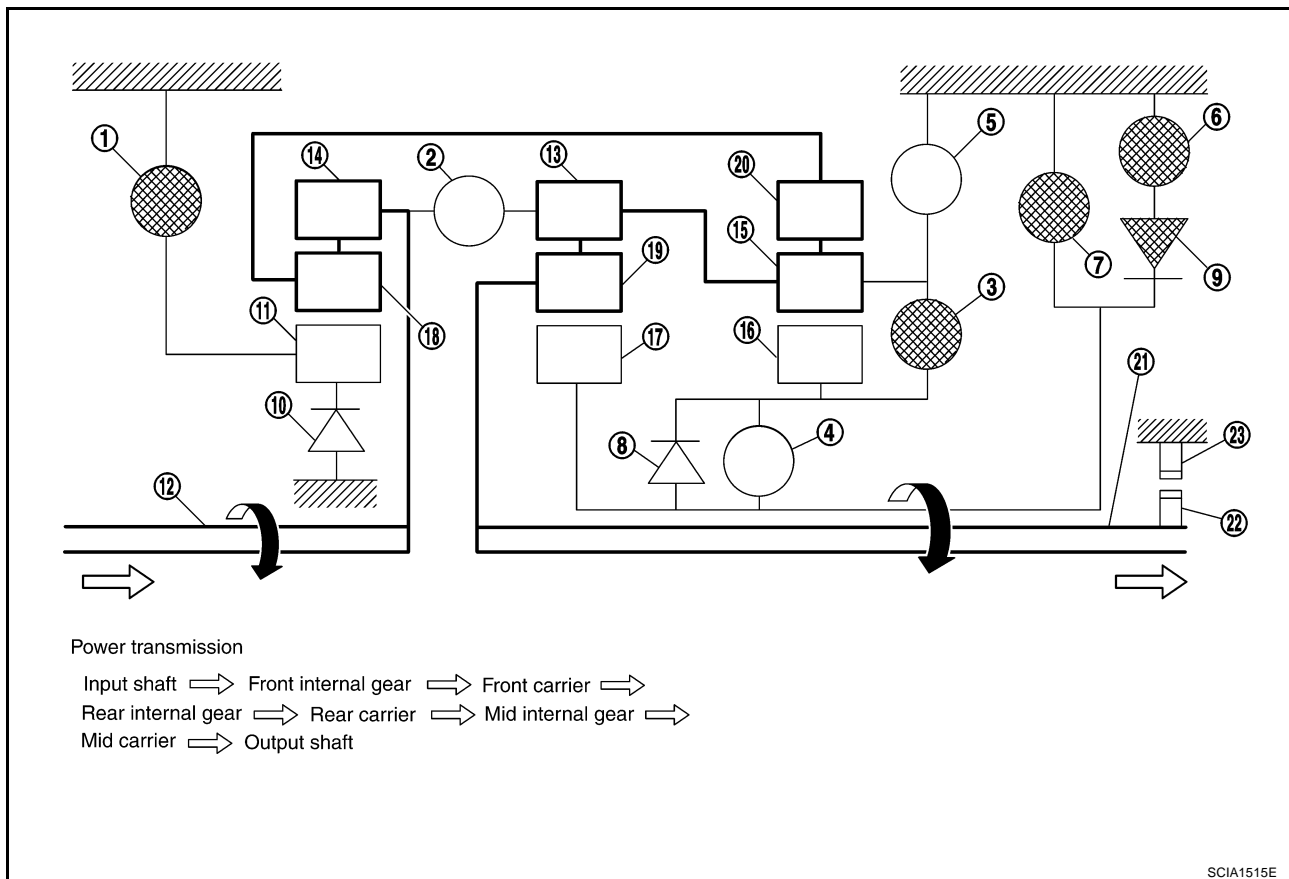

- |                                |                         |                           |
|--------------------------------|-------------------------|---------------------------|
| 1. Front brake                 | 2. Input clutch         | 3. Direct clutch          |
| 4. High and low reverse clutch | 5. Reverse brake        | 6. Forward brake          |
| 7. Low coast brake             | 8. 1st one-way clutch   | 9. Forward one-way clutch |
| 10. 3rd one-way clutch         | 11. Front sun gear      | 12. Input shaft           |
| 13. Mid internal gear          | 14. Front internal gear | 15. Rear carrier          |
| 16. Rear sun gear              | 17. Mid sun gear        | 18. Front carrier         |
| 19. Mid carrier                | 20. Rear internal gear  | 21. Output shaft          |
| 22. Parking gear               | 23. Parking pawl        |                           |

**“D3” and “M3” position**

- The front brake fastens the front sun gear.
- The direct clutch is coupled, and the rear carrier and rear sun gear are connected.
- The high and low reverse clutch is coupled, and the mid sun gear and rear sun gear are connected.

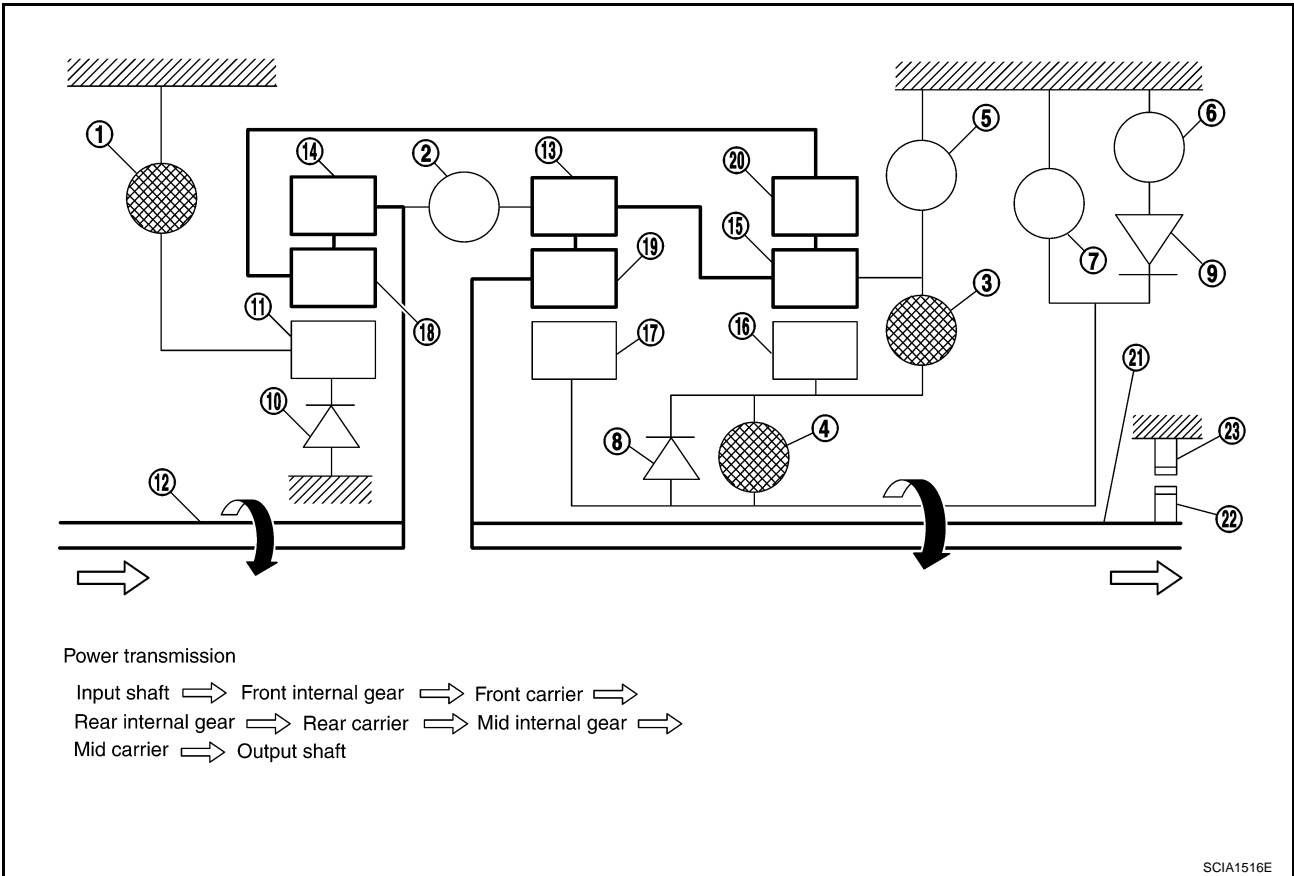

- |                                |                         |                           |
|--------------------------------|-------------------------|---------------------------|
| 1. Front brake                 | 2. Input clutch         | 3. Direct clutch          |
| 4. High and low reverse clutch | 5. Reverse brake        | 6. Forward brake          |
| 7. Low coast brake             | 8. 1st one-way clutch   | 9. Forward one-way clutch |
| 10. 3rd one-way clutch         | 11. Front sun gear      | 12. Input shaft           |
| 13. Mid internal gear          | 14. Front internal gear | 15. Rear carrier          |
| 16. Rear sun gear              | 17. Mid sun gear        | 18. Front carrier         |
| 19. Mid carrier                | 20. Rear internal gear  | 21. Output shaft          |
| 22. Parking gear               | 23. Parking pawl        |                           |

A  
B  
AT  
D  
E  
F  
G  
H  
I  
J  
K  
L  
M

## “D4 ” and “M4” position

- The direct clutch is coupled, and the rear carrier and rear sun gear are connected.
- The high and low reverse clutch is coupled, and the mid sun gear and rear sun gear are connected.
- The input clutch is coupled, and the front internal gear and mid internal gear are connected.
- The drive power is conveyed to the front internal gear, mid internal gear, and rear carrier and the three planetary gears rotate forward as one unit.

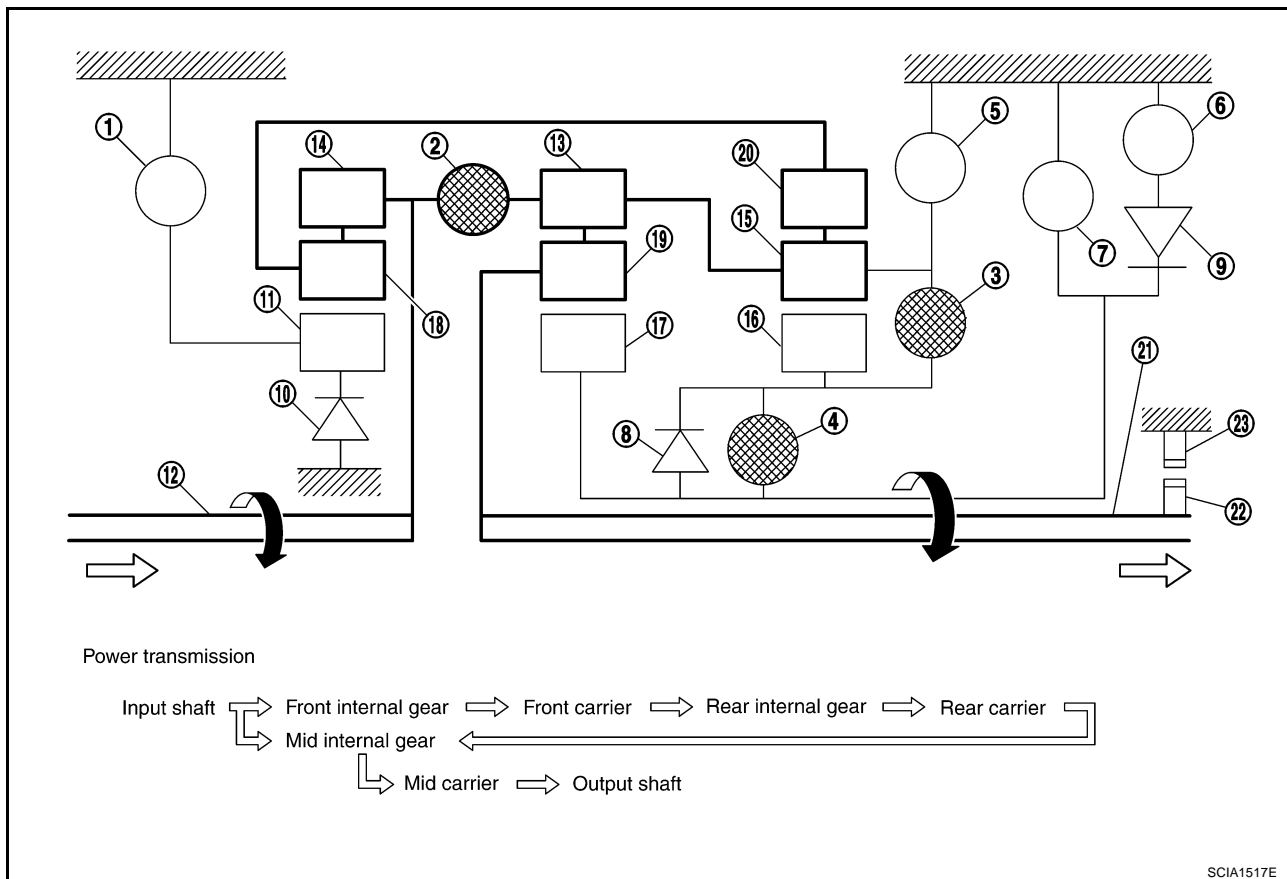

- |                                |                         |                           |
|--------------------------------|-------------------------|---------------------------|
| 1. Front brake                 | 2. Input clutch         | 3. Direct clutch          |
| 4. High and low reverse clutch | 5. Reverse brake        | 6. Forward brake          |
| 7. Low coast brake             | 8. 1st one-way clutch   | 9. Forward one-way clutch |
| 10. 3rd one-way clutch         | 11. Front sun gear      | 12. Input shaft           |
| 13. Mid internal gear          | 14. Front internal gear | 15. Rear carrier          |
| 16. Rear sun gear              | 17. Mid sun gear        | 18. Front carrier         |
| 19. Mid carrier                | 20. Rear internal gear  | 21. Output shaft          |
| 22. Parking gear               | 23. Parking pawl        |                           |



**“D5” and “M5” position**

- The front brake fastens the front sun gear.
- The input clutch is coupled, and the front internal gear and mid internal gear are connected.
- The high and low reverse clutch is coupled, and the mid sun gear and rear sun gear are connected.

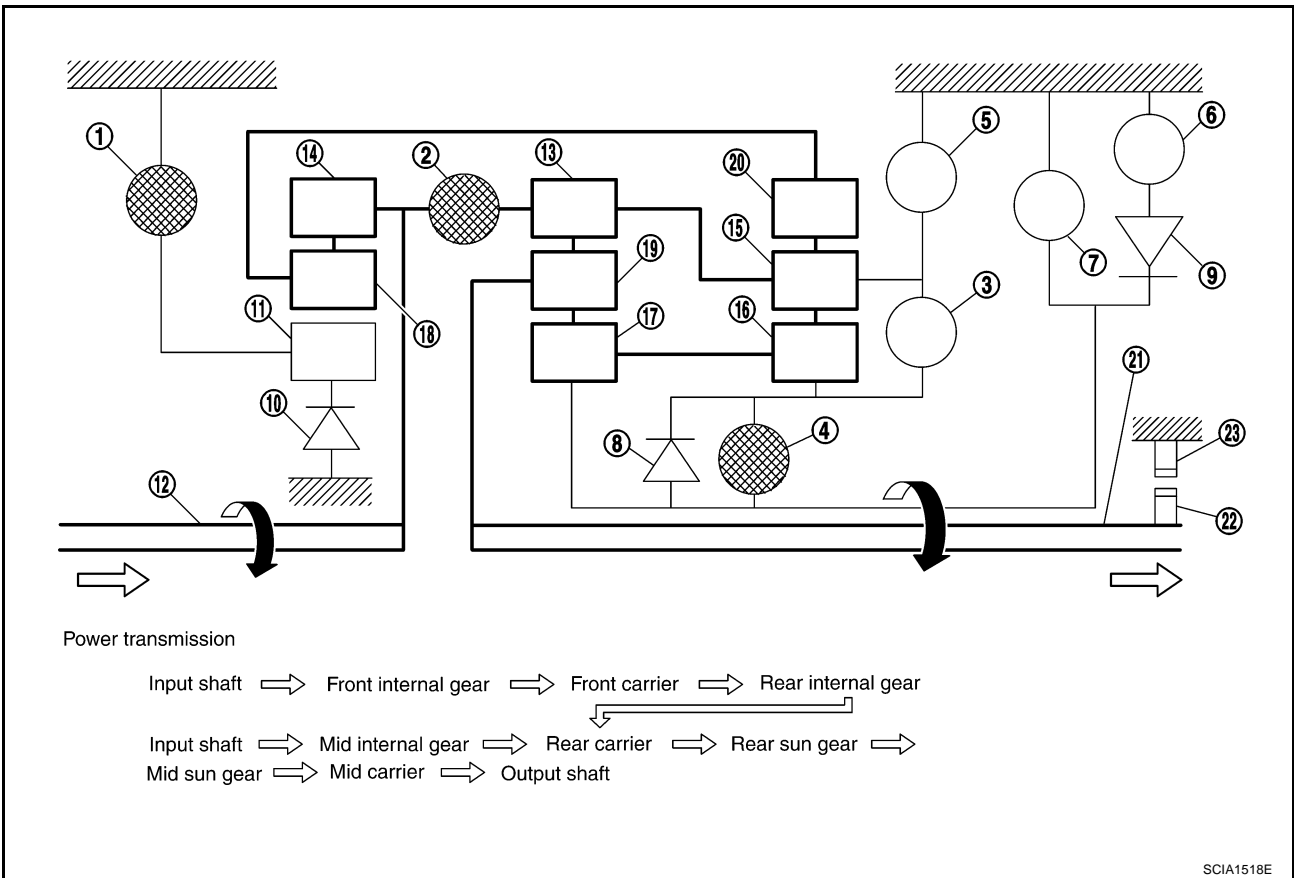

- |                                |                         |                           |
|--------------------------------|-------------------------|---------------------------|
| 1. Front brake                 | 2. Input clutch         | 3. Direct clutch          |
| 4. High and low reverse clutch | 5. Reverse brake        | 6. Forward brake          |
| 7. Low coast brake             | 8. 1st one-way clutch   | 9. Forward one-way clutch |
| 10. 3rd one-way clutch         | 11. Front sun gear      | 12. Input shaft           |
| 13. Mid internal gear          | 14. Front internal gear | 15. Rear carrier          |
| 16. Rear sun gear              | 17. Mid sun gear        | 18. Front carrier         |
| 19. Mid carrier                | 20. Rear internal gear  | 21. Output shaft          |
| 22. Parking gear               | 23. Parking pawl        |                           |

A  
B  
AT  
D  
E  
F  
G  
H  
I  
J  
K  
L  
M

**“R” position**

- The front brake fastens the front sun gear.
- The high and low reverse clutch is coupled, and the mid sun gear and rear sun gear are connected.
- The reverse brake fastens the rear carrier.

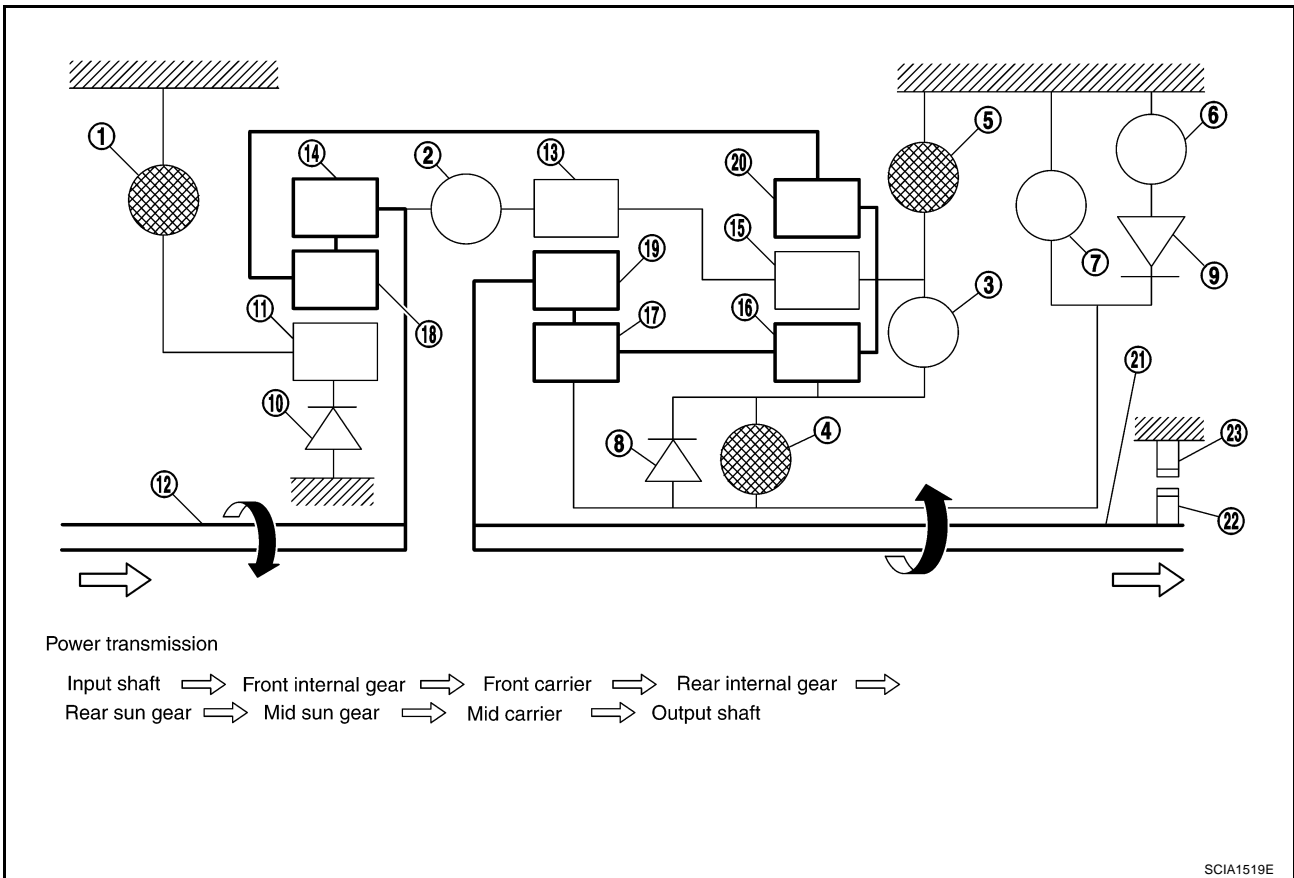

- |                                |                         |                           |
|--------------------------------|-------------------------|---------------------------|
| 1. Front brake                 | 2. Input clutch         | 3. Direct clutch          |
| 4. High and low reverse clutch | 5. Reverse brake        | 6. Forward brake          |
| 7. Low coast brake             | 8. 1st one-way clutch   | 9. Forward one-way clutch |
| 10. 3rd one-way clutch         | 11. Front sun gear      | 12. Input shaft           |
| 13. Mid internal gear          | 14. Front internal gear | 15. Rear carrier          |
| 16. Rear sun gear              | 17. Mid sun gear        | 18. Front carrier         |
| 19. Mid carrier                | 20. Rear internal gear  | 21. Output shaft          |
| 22. Parking gear               | 23. Parking pawl        |                           |

## TCM Function

The function of the TCM is to:

- Receive input signals sent from various switches and sensors.
- Determine required line pressure, shifting point, lock-up operation, and engine brake operation.
- Send required output signals to the respective solenoids.

## CONTROL SYSTEM OUTLINE

The automatic transmission senses vehicle operating conditions through various sensors or signals. It always controls the optimum shift position and reduces shifting and lock-up shocks.

SENSORS (or SIGNALS)		TCM		ACTUATORS
PNP switch Throttle position sensor Accelerator pedal position sensor Closed throttle position signal Wide open throttle position signal Engine speed signal A/T fluid temperature sensor Revolution sensor Vehicle speed sensor Manual mode switch signal Stop lamp switch signal Turbine revolution sensor	⇒	Shift control Line pressure control Lock-up control Engine brake control Timing control Fail-safe control Self-diagnosis CONSULT-II communication line Duet-EA control CAN system	⇒	Input clutch solenoid valve Direct clutch solenoid valve Front brake solenoid valve High & low reverse clutch solenoid valve Low coast brake solenoid valve Torque converter clutch solenoid valve Line pressure solenoid valve A/T CHECK indicator lamp

## CONTROL SYSTEM DIAGRAM

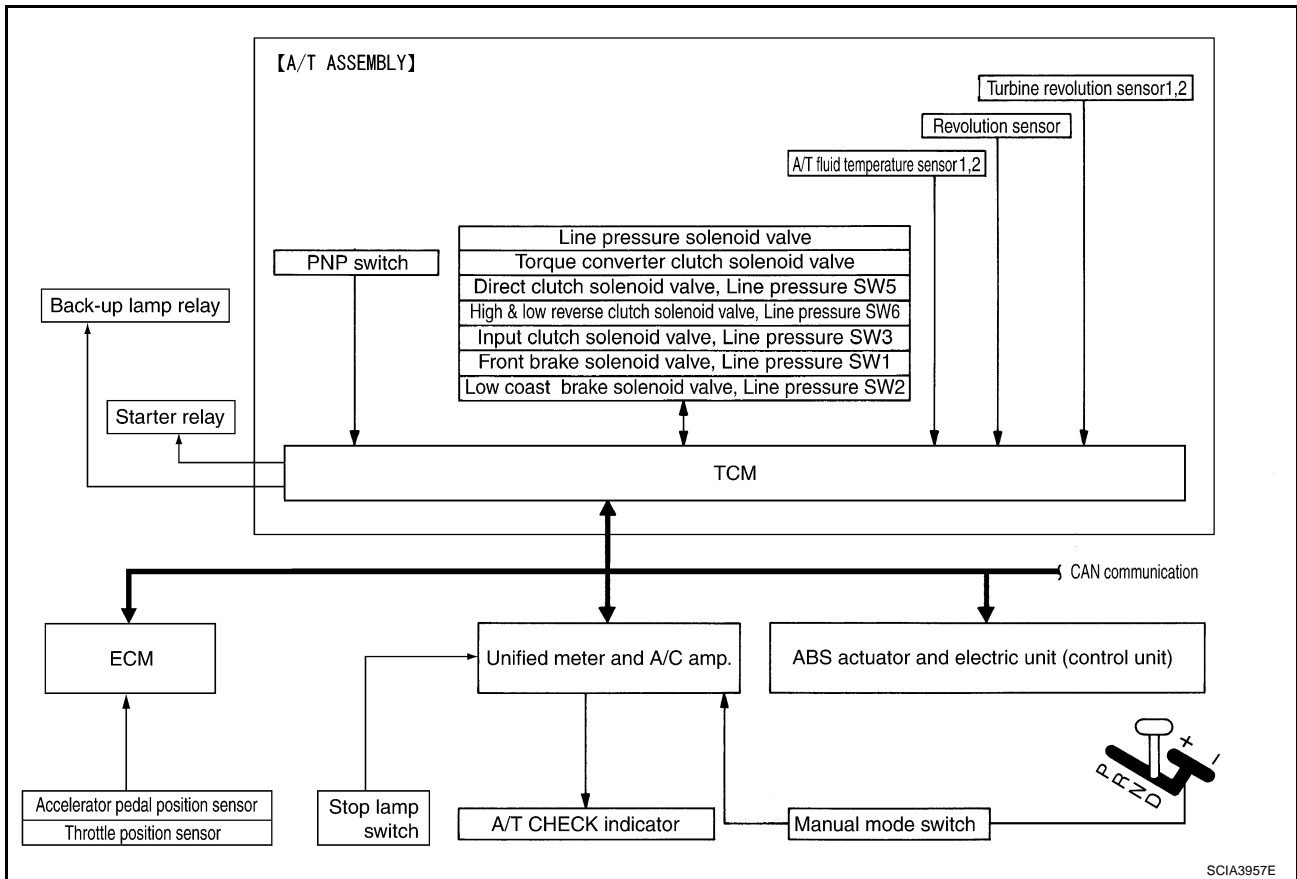

## CAN Communication SYSTEM DESCRIPTION

ACS000H6

CAN (Controller Area Network) is a serial communication line for real time application. It is an on-vehicle multiplex communication line with high data communication speed and excellent error detection ability. Many electronic control units are equipped onto a vehicle, and each control unit shares information and links with other control units during operation (not independent). In CAN communication, control units are connected with 2 communication lines (CAN H line, CAN L line) allowing a high rate of information transmission with less wiring. Each control unit transmits/receives data but selectively reads required data only. For details, refer to [LAN-5, "CAN Communication Unit"](#)

## Input/Output Signal of TCM

ACS000H7

Control item		Line pressure control	Vehicle speed control	Shift control	Lock-up control	Engine brake control	Fail-safe function (*3)	Self-diagnostics function	
Input	Accelerator pedal position signal (*5)	X	X	X	X	X	X	X	
	Vehicle speed sensor A/T (revolution sensor)	X	X	X	X		X	X	
	Vehicle speed sensor MTR(*1) (*5)	X	X	X	X			X	
	Closed throttle position signal(*5)	(*2) X	(*2) X		X	(*2) X		(*4) X	
	Wide open throttle position signal(*5)	(*2) X	(*2) X			(*2) X		(*4) X	
	Turbine revolution sensor 1	X	X		X		X	X	
	Turbine revolution sensor 2 (for 4th speed only)	X	X		X		X	X	
	Engine speed signals(*5)				X			X	
	PNP switch	X	X	X	X	X	X	(*4) X	
	Stop lamp switch signal(*5)		X			X		(*4) X	
	A/T fluid temperature sensors 1, 2	X	X	X	X	X	X	X	
	ASCD	Operation signal(*5)		X	X	X	X		
		Overdrive cancel signal(*5)		X		X	X		
	TCM power supply voltage signal		X	X	X	X	X		X
Output	Direct clutch solenoid (ATF pressure switch 5)		X	X			X	X	
	Input clutch solenoid (ATF pressure switch 3)		X	X			X	X	
	High & low reverse clutch solenoid (ATF pressure switch 6)		X	X			X	X	
	Front brake solenoid (ATF pressure switch 1)		X	X			X	X	
	Low coast brake solenoid (ATF pressure switch 2)		X	X		X	X	X	
	Line pressure solenoid	X	X	X	X	X	X	X	
	TCC solenoid				X		X	X	
	Self-diagnostics table(*5)							X	
Starter relay							X	X	

\*1: Spare for vehicle speed sensor-A/T (revolution sensor)

\*2: Spare for accelerator pedal position signal

\*3: If these input and output signals are different, the TCM triggers the fail-safe function.

\*4: Used as a condition for starting self-diagnostics; if self-diagnostics are not started, it is judged that there is some kind of error.

\*5: CAN communications

## Line Pressure Control

ACS000HB

- When an input torque signal equivalent to the engine drive force is sent from the ECM to the TCM, the TCM controls the line pressure solenoid.
- This line pressure solenoid controls the pressure regulator valve as the signal pressure and adjusts the pressure of the operating oil discharged from the oil pump to the line pressure most appropriate to the driving state.

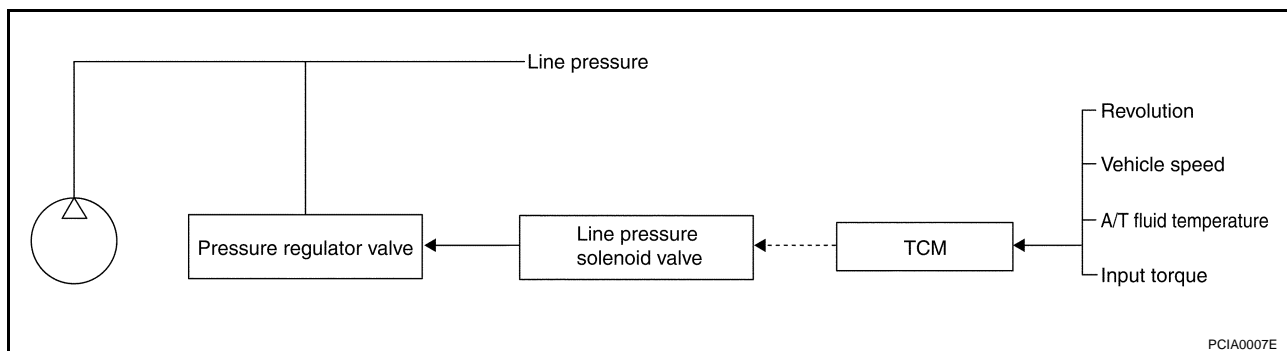

### LINE PRESSURE CONTROL IS BASED ON THE TCM LINE PRESSURE CHARACTERISTIC PATTERN

- The TCM has stored in memory a number of patterns for the optimum line pressure characteristic for the driving state.
- In order to obtain the most appropriate line pressure characteristic to meet the current driving state, the TCM controls the line pressure solenoid current valve and thus controls the line pressure.

#### Normal control

Each clutch is adjusted to the necessary pressure to match the engine drive force.

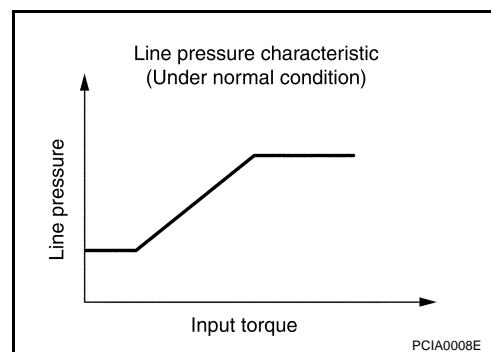

#### Back-up control (Engine brake)

When the select operation is executed during driving and the transmission is shifted down, the line pressure is set according to the vehicle speed.

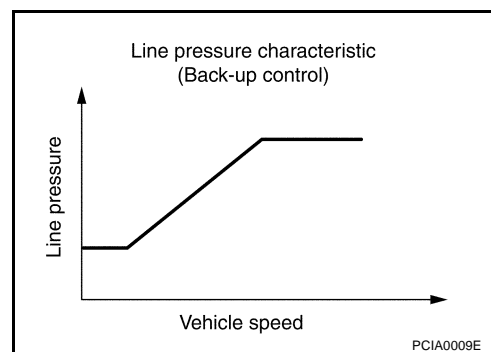

### During shift change

The necessary and adequate line pressure for shift change is set. For this reason, line pressure pattern setting corresponds to input torque and gearshift selection. Also, line pressure characteristic is set according to engine speed, during engine brake operation.

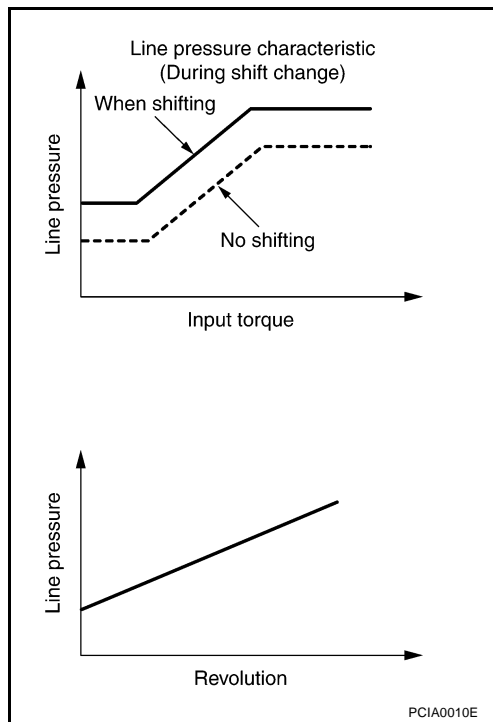

### At low fluid temperature

When the A/T fluid temperature drops below the prescribed temperature, in order to speed up the action of each friction element, the line pressure is set higher than the normal line pressure characteristic.

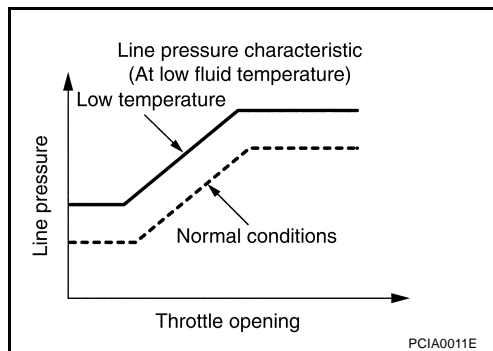

### Shift Control

ACS000H9

The clutch pressure control solenoid is controlled by the signals from the switches and sensors. Thus, the clutch pressure is adjusted to be appropriate to the engine load state and vehicle driving state. It becomes possible to finely control the clutch hydraulic pressure with high precision and a smoother shift change characteristic is attained.

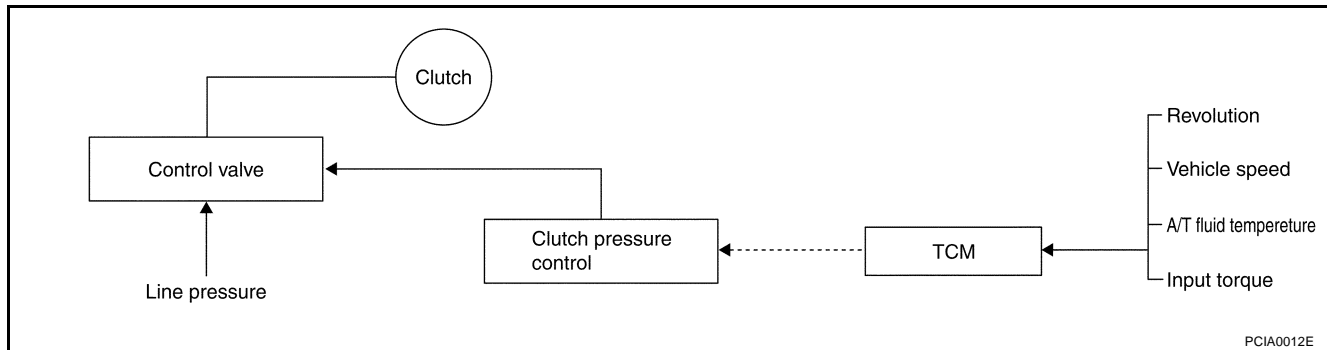

### SHIFT CHANGE

The clutch is controlled with the optimum timing and oil pressure by the engine speed, engine torque information, etc.

## Shift change system diagram

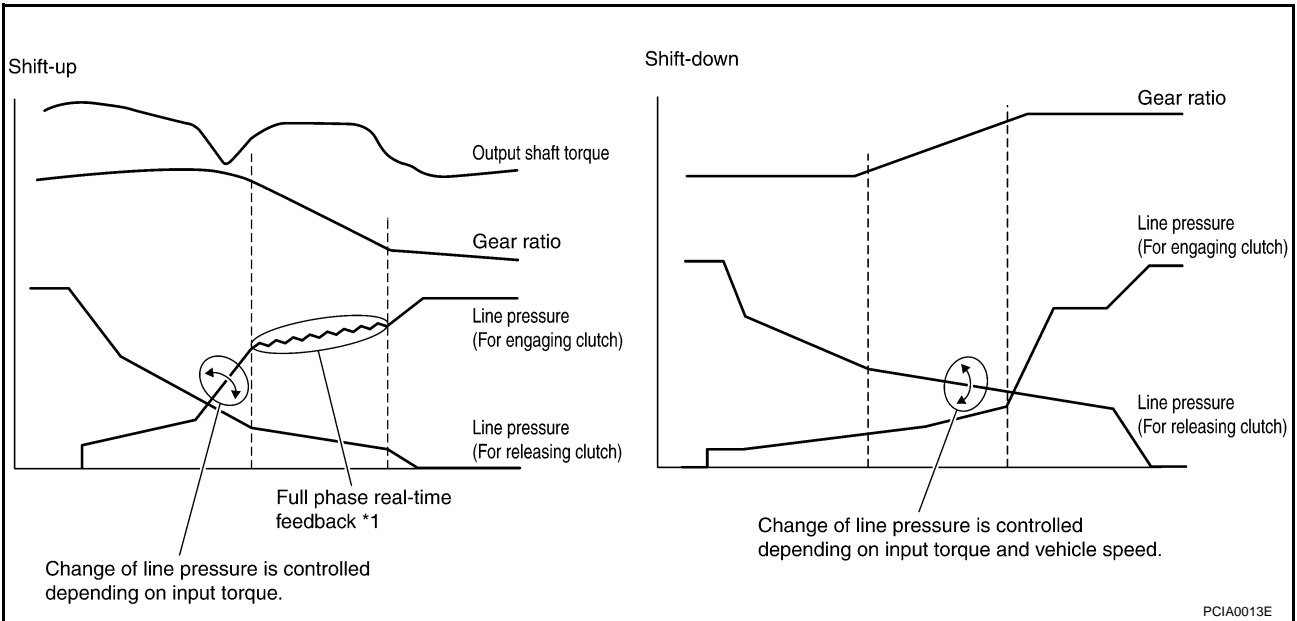

\*1: Full phase real-time feedback control monitors movement of gear ratio at gear change, and controls oil pressure at real-time to achieve the best gear ratio.

## Lock-Up Control

ACS000HA

The torque converter clutch piston in the torque converter is engaged to eliminate torque converter slip to increase power transmission efficiency.

The torque converter clutch control valve operation is controlled by the torque converter clutch solenoid valve, which is controlled by a signal from TCM, and the torque converter clutch control valve engages or releases the torque converter clutch piston.

### Lock-up Operation Condition Table

Select lever	D position		M5 position	M4 position	M3 position	M2 position
Gear position	5	4	5	4	3	2
Lock-up	×	—	×	×	×	×
Slip lock-up	×	×	—	—	—	—

## TORQUE CONVERTER CLUTCH CONTROL VALVE CONTROL

### Lock-up control system diagram

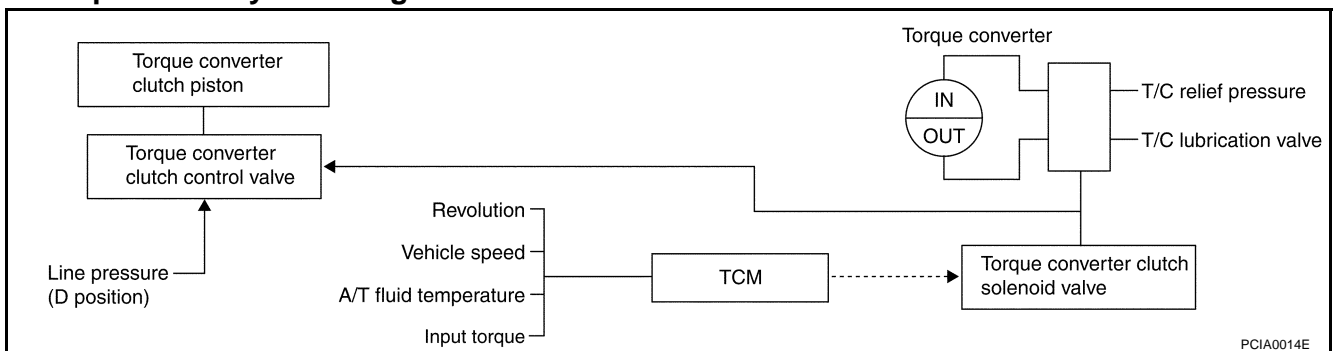

### Lock-up released

- In the lock-up released state, the torque converter clutch control valve is set into the unlocked state by the torque converter clutch solenoid and the lock-up apply pressure is drained. In this way, the torque converter clutch piston is not coupled.

### **Lock-up applied**

- In the lock-up applied state, the torque converter clutch control valve is set into the locked state by the torque converter clutch solenoid and lock-up apply pressure is generated. In this way, the torque converter clutch piston is pressed and coupled.

### **SMOOTH LOCK-UP CONTROL**

When shifting from the lock-up released state to the lock-up applied state, the current output to the torque converter clutch solenoid is controlled with the TCM. In this way, when shifting to the lock-up applied state, the torque converter clutch is temporarily set to the half-clutched state to reduce the shock.

### **Half-clutched state**

- The current output from the TCM to the torque converter clutch solenoid is varied to gradually increase the torque converter clutch solenoid pressure. In this way, the lock-up apply pressure gradually rises and while the torque converter clutch piston is put into half-clutched status, the torque converter clutch piston operating pressure is increased and the coupling is completed smoothly.

### **Slip lock-up control**

- In the slip region, the torque converter clutch solenoid current is controlled with the TCM to put it into the half-clutched state. This absorbs the engine torque fluctuation and lock-up operates from low speed. This raises the fuel efficiency for 4th and 5th gears at both low speed and when the accelerator has a low degree of opening.



## Engine Brake Control

ACS000HB

- The forward one-way clutch transmits the drive force from the engine to the rear wheels. But the reverse drive from the rear wheels is not transmitted to the engine because the one-way clutch is idling. Therefore, the low coast brake solenoid is operated to prevent the forward one-way clutch from idling and the engine brake is operated in the same manner as conventionally.

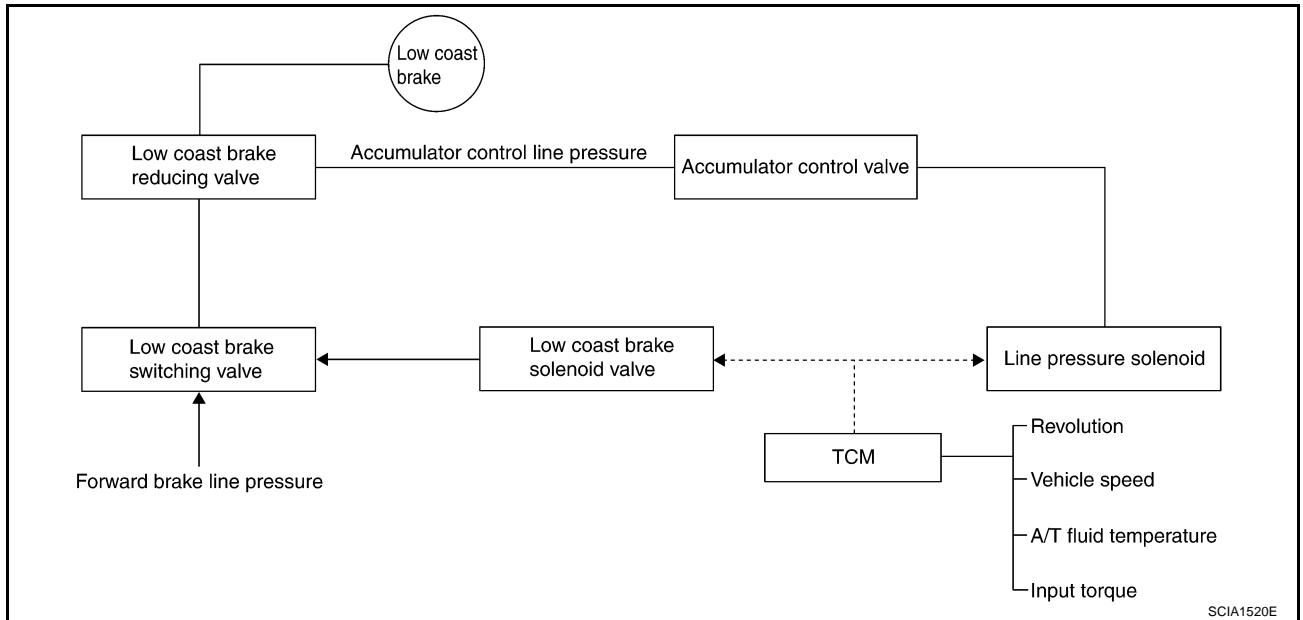

- The operation of the low coast brake solenoid switches the low coast brake switching valve and controls the coupling and releasing of the low coast brake. The low coast brake reducing valve controls the low coast brake coupling force.

## Control Valve

ACS000HC

### FUNCTION OF CONTROL VALVE

Name	Function
Torque converter regulator valve	In order to prevent the pressure supplied to the torque converter from being excessive, the line pressure is adjusted to the optimum pressure (torque converter operating pressure).
Pressure regulator valve Pressure regulator plug Pressure regulator sleeve	Adjusts the oil discharged from the oil pump to the optimum pressure (line pressure) for the driving state.
Front brake control valve	When the front brake is coupled, adjusts the line pressure to the optimum pressure (front brake pressure) and supplies it to the front brake. (In 1st, 2nd, 3rd, and 5th gears, adjusts the clutch pressure.)
Accumulator control valve	Adjusts the pressure (accumulator control pressure) acting on the accumulator piston and low coast reducing valve to the pressure appropriate to the driving state.
Pilot valve A	Adjusts the line pressure and produces the constant pressure (pilot pressure) required for line pressure control, shift change control, and lock-up control.
Pilot valve B	Adjusts the line pressure and produces the constant pressure (pilot pressure) required for shift change control.
Low coast brake switching valve	During engine braking, supplies the line pressure to the low coast brake reducing valve.
Low coast brake reducing valve	When the low coast brake is coupled, adjusts the line pressure to the optimum pressure (low coast brake pressure) and supplies it to the low coast brake.
N-R accumulator	Produces the stabilizing pressure for when N-R is selected.
Direct clutch piston switching valve	Operates in 4th gear and switches the direct clutch coupling capacity.
High and low reverse clutch control valve	When the high and low reverse clutch is coupled, adjusts the line pressure to the optimum pressure (high and low reverse clutch pressure) and supplies it to the high and low reverse clutch. (In 1st, 3rd, 4th and 5th gears, adjusts the clutch pressure.)

Name	Function
Input clutch control valve	When the input clutch is coupled, adjusts the line pressure to the optimum pressure (input clutch pressure) and supplies it to the input clutch. (In 4th and 5th gears, adjusts the clutch pressure.)
Direct clutch control valve	When the direct clutch is coupled, adjusts the line pressure to the optimum pressure (direct clutch pressure) and supplies it to the direct clutch. (In 2nd, 3rd, and 4th gears, adjusts the clutch pressure.)
TCC control valve TCC control plug TCC control sleeve	Switches the lock-up to operating or released. Also, by executing the lock-up operation transiently, lock-up smoothly.
Torque converter lubrication valve	Operates during lock-up to switch the torque converter, cooling, and lubrication system oil path.
Cool bypass valve	Allows excess oil to bypass cooler circuit without being fed into it.
Line pressure relief valve	Discharges excess oil from line pressure circuit.
N-D accumulator	Produces the stabilizing pressure for when N-D is selected.
Manual valve	Sends line pressure to each circuit according to the select position. The circuits to which the line pressure is not sent drain.

## FUNCTION OF ATF PRESSURE SWITCH

Name	Function
ATF pressure switch 1 (FR/B)	Detects any malfunction in the front brake hydraulic pressure. When it detects any malfunction, it puts the system into fail-safe mode.
ATF pressure switch 2 (LC/B)	Detects any malfunction in the low coast brake hydraulic pressure. When it detects any malfunction, it puts the system into fail-safe mode.
ATF pressure switch 3 (I/C)	Detects any malfunction in the input clutch hydraulic pressure. When it detects any malfunction, it puts the system into fail-safe mode.
ATF pressure switch 5 (D/C)	Detects any malfunction in the direct clutch hydraulic pressure. When it detects any malfunction, it puts the system into fail-safe mode.
ATF pressure switch 6 (H&LR/C)	Detects any malfunction in the high & low reverse clutch hydraulic pressure. When it detects any malfunction, it puts the system into fail-safe mode.

## ON BOARD DIAGNOSTIC (OBD) SYSTEM

PFP:00028

### Introduction

ACS000HD

The A/T system has two self-diagnostic systems.

The first is the emission-related on board diagnostic system (OBD-II) performed by the TCM in combination with the ECM. The malfunction is indicated by the MIL (malfunction indicator lamp) and is stored as a DTC in the ECM memory but not the TCM memory.

The second is the TCM original self-diagnosis indicated by the A/T CHECK indicator lamp. The malfunction is stored in the TCM memory. The detected items are overlapped with OBD-II self-diagnostic items. For detail, refer to [AT-77, "Self-diagnostic result test mode"](#).

### OBD-II Function for A/T System

ACS000HE

The ECM provides emission-related on board diagnostic (OBD-II) functions for the A/T system. One function is to receive a signal from the TCM used with OBD-related parts of the A/T system. The signal is sent to the ECM when a malfunction occurs in the corresponding OBD-related part. The other function is to indicate a diagnostic result by means of the MIL (malfunction indicator lamp) on the instrument panel. Sensors, switches and solenoid valves are used as sensing elements.

The MIL automatically illuminates in One or Two Trip Detection Logic when a malfunction is sensed in relation to A/T system parts.

### One or Two Trip Detection Logic of OBD-II

ACS000HF

#### ONE TRIP DETECTION LOGIC

If a malfunction is sensed during the first test drive, the MIL will illuminate and the malfunction will be stored in the ECM memory as a DTC. The TCM is not provided with such a memory function.

#### TWO TRIP DETECTION LOGIC

When a malfunction is sensed during the first test drive, it is stored in the ECM memory as a 1st trip DTC (diagnostic trouble code) or 1st trip freeze frame data. At this point, the MIL will not illuminate. — First Trip

If the same malfunction as that experienced during the first test drive is sensed during the second test drive, the MIL will illuminate. — Second Trip



The "trip" in the "One or Two Trip Detection Logic" means a driving mode in which self-diagnosis is performed during vehicle operation.

### OBD-II Diagnostic Trouble Code (DTC)

ACS000HG

#### HOW TO READ DTC AND 1ST TRIP DTC

DTC and 1st trip DTC can be read by the following methods.

( with **CONSULT-II** or ( **GST**) CONSULT-II or GST (Generic Scan Tool) Examples: P0705, P0720 etc. These DTC are prescribed by SAE J2012.

(CONSULT-II also displays the malfunctioning component or system.)

- **1st trip DTC No. is the same as DTC No.**
- **Output of the diagnostic trouble code indicates that the indicated circuit has a malfunction. However, in case of the Mode II and GST, they do not indicate whether the malfunction is still occurring or occurred in the past and returned to normal.**  
**CONSULT-II can identify them as shown below, therefore, CONSULT-II (if available) is recommended.**

A sample of CONSULT-II display for DTC and 1st trip DTC is shown on the next page. DTC or 1st trip DTC of a malfunction is displayed in SELF-DIAGNOSTIC RESULTS mode for "ENGINE" with CONSULT-II. Time data indicates how many times the vehicle was driven after the last detection of a DTC.

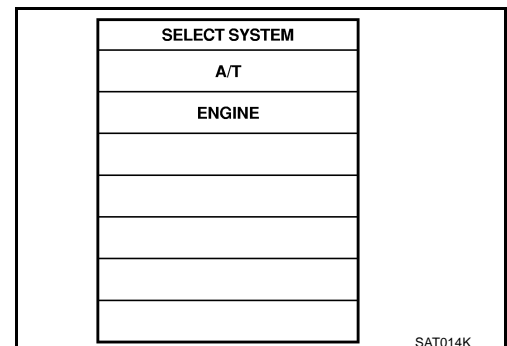

If the DTC is being detected currently, the time data will be "0".

SELF-DIAG RESULTS	
DTC RESULTS	TIME
PNP SW/CIRC [P0705]	0

SAT015K

If a 1st trip DTC is stored in the ECM, the time data will be "1t".

SELF-DIAG RESULTS	
DTC RESULTS	TIME
PNP SW/CIRC [P0705]	1 t

SAT016K

### Freeze frame data and 1st trip freeze frame data

The ECM has a memory function, which stores the driving condition such as fuel system status, calculated load value, engine coolant temperature, short term fuel trim, long term fuel trim, engine speed and vehicle speed at the moment the ECM detects a malfunction.

Data which are stored in the ECM memory, along with the 1st trip DTC, are called 1st trip freeze frame data, and the data, stored together with the DTC data, are called freeze frame data and displayed on CONSULT-II or GST. The 1st trip freeze frame data can only be displayed on the CONSULT-II screen, not on the GST. For detail, refer to [EC-103, "CONSULT-II Function"](#).

Only one set of freeze frame data (either 1st trip freeze frame data or freeze frame data) can be stored in the ECM. 1st trip freeze frame data is stored in the ECM memory along with the 1st trip DTC. There is no priority for 1st trip freeze frame data and it is updated each time a different 1st trip DTC is detected. However, once freeze frame data (2nd trip detection/MIL on) is stored in the ECM memory, 1st trip freeze frame data is no longer stored. Remember, only one set of freeze frame data can be stored in the ECM. The ECM has the following priorities to update the data.

Priority	Items
1	Freeze frame data Misfire — DTC: P0300 - P0306 Fuel Injection System Function — DTC: P0171, P0172, P0174, P0175
2	Except the above items (Includes A/T related items)
3	1st trip freeze frame data

Both 1st trip freeze frame data and freeze frame data (along with the DTC) are cleared when the ECM memory is erased.

### HOW TO ERASE DTC

The diagnostic trouble code can be erased by CONSULT-II, GST or ECM DIAGNOSTIC TEST MODE as described following.

- **If the battery cable is disconnected, the diagnostic trouble code will be lost within 24 hours.**
- **When you erase the DTC, using CONSULT-II or GST is easier and quicker than switching the mode selector on the ECM.**

The following emission-related diagnostic information is cleared from the ECM memory when erasing DTC related to OBD-II. For details, refer to [EC-47, "Emission-related Diagnostic Information"](#).

- **Diagnostic trouble codes (DTC)**
- **1st trip diagnostic trouble codes (1st trip DTC)**
- **Freeze frame data**

- 1st trip freeze frame data
- System readiness test (SRT) codes
- Test values

## 📱 HOW TO ERASE DTC (WITH CONSULT-II)

- If a DTC is displayed for both ECM and TCM, it is necessary to be erased for both ECM and TCM.
1. If the ignition switch stays "ON" after repair work, be sure to turn ignition switch "OFF" once. Wait at least 10 seconds and then turn it "ON" (engine stopped) again.
  2. Turn CONSULT-II "ON" and touch "A/T".
  3. Touch "SELF-DIAG RESULTS".
  4. Touch "ERASE". (The DTC in the TCM will be erased.) Then touch "BACK" twice.
  5. Touch "ENGINE".
  6. Touch "SELF-DIAG RESULTS".
  7. Touch "ERASE". (The DTC in the ECM will be erased.)

### How to erase DTC (With CONSULT-II)

1. If the ignition switch stays "ON" after repair work, be sure to turn ignition switch "OFF" once. Wait at least 10 seconds and then turn it "ON" (engine stopped) again.

SELECT SYSTEM
A/T
ENGINE

2. Turn CONSULT-II "ON", and touch "A/T".

SELECT DIAG MODE
SELF-DIAG RESULTS
DATA MONITOR
DTC WORK SUPPORT
ECU PART NUMBER

3. Touch "SELF-DIAG RESULTS".

SELF-DIAG RESULTS
DTC RESULTS
TCC SOLENOID/CIRC [P0740]

4. Touch "ERASE". (The DTC in the TCM will be erased.)

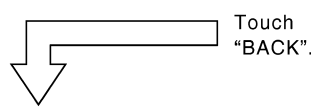

SELECT SYSTEM
A/T
ENGINE

5. Touch "ENGINE".

SELECT DIAG MODE
WORK SUPPORT
SELF-DIAG RESULTS
DATA MONITOR
ACTIVE TEST
DTC & SRT CONFIRMATION
ECM PART NUMBER

6. Touch "SELF-DIAG RESULTS".

SELF-DIAG RESULTS	
DTC RESULTS	TIME
TCC SOLENOID/CIRC [P0740]	0

7. Touch "ERASE". (The DTC in the ECM will be erased.)

SCIA1477E

## 📱 HOW TO ERASE DTC (WITH GST)

1. If the ignition switch stays "ON" after repair work, be sure to turn ignition switch "OFF" once. Wait at least 10 seconds and then turn it "ON" (engine stopped) again.
2. Perform "TCM SELF-DIAGNOSTIC PROCEDURE (No Tools)". Refer to [AT-87, "TCM SELF-DIAGNOSTIC PROCEDURE \(NO TOOLS\)"](#). (The engine warm-up step can be skipped when performing the diagnosis only to erase the DTC.)
3. Select Mode 4 with Generic Scan Tool (GST). For details, refer to [EC-116, "Generic Scan Tool \(GST\) Function"](#).



## HOW TO ERASE DTC (NO TOOLS)

The A/T CHECK indicator lamp is located on the instrument panel.

1. If the ignition switch stays "ON" after repair work, be sure to turn ignition switch "OFF" once. Wait at least 10 seconds and then turn it "ON" (engine stopped) again.
2. Perform "TCM SELF-DIAGNOSTIC PROCEDURE (No Tools)". Refer to [AT-87, "TCM SELF-DIAGNOSTIC PROCEDURE \(NO TOOLS\)"](#) . (The engine warm-up step can be skipped when performing the diagnosis only to erase the DTC.)
3. Perform "OBD-II SELF-DIAGNOSTIC PROCEDURE (No tools)". Refer to [EC-60, "How to Erase DTC"](#) .

## Malfunction Indicator Lamp (MIL) DESCRIPTION

ACS000HH

The MIL is located on the instrument panel.

1. The MIL will light up when the ignition switch is turned "ON" without the engine running. This is a bulb check.
  - If the MIL does not light up, refer to [DI-69, "WARNING LAMPS"](#) , or see [EC-621, "MIL AND DATA LINK CONNECTOR"](#) .
2. When the engine is started, the MIL should go off. If the MIL remains on, the on board diagnostic system has detected an engine system malfunction.

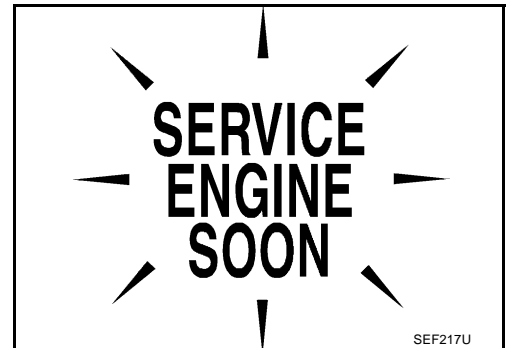

## TROUBLE DIAGNOSIS

PFP:00004

### DTC Inspection Priority Chart

ACS000HI

If some DTCs are displayed at the same time, perform inspections one by one based on the following priority chart.

**NOTE:**

**If DTC U1000 is displayed with other DTCs, first perform the trouble diagnosis for DTC U1000. Refer to [AT-89](#).**

Priority	Detected items (DTC)
1	U1000 CAN communication line
2	Except above

### Fail-Safe

ACS000HJ

The TCM has an electrical fail-safe mode. This mode makes it possible to operate even if there is a an error in a main electronic control input/output signal circuit.

In fail-safe mode, even if the select lever is “D” or “M” mode, the transmission is fixed in 2nd, 4th, or 5th (depending on the breakdown position), so the customer should feel “slipping” or “poor acceleration”. When fail-safe mode is triggered, when the ignition switch is switched “ON”, the A/T CHECK indicator lamp flashes for about 8 seconds. (Refer to [AT-87, "TCM SELF-DIAGNOSTIC PROCEDURE \(NO TOOLS\)"](#) ).

Even when the electronic circuits are normal, under special conditions (for example, when slamming on the brake with the wheels spinning drastically and stopping the tire rotation), the transmission can go into fail-safe mode. If this happens, switch “OFF” the ignition switch for 10 seconds, then switch it “ON” again to return to the normal shift pattern. Also, the A/T CHECK indicator lamp flashes for about 8 seconds once, then is cleared. Therefore, the customer's vehicle has returned to normal, so handle according to the “diagnostics flow” (Refer to [AT-42](#) ).

### FAIL-SAFE FUNCTION

If any malfunction occurs in a sensor or solenoid, this function controls the A/T to mark driving possible.

#### Vehicle speed sensor A/T (revolution sensor)

- Signals are input from two systems - from vehicle speed sensor A/T (revolution sensor) installed on the transmission and from combination meter so normal driving is possible even if there is a malfunction in one of the systems. And if vehicle speed sensor A/T (revolution sensor) has unusual cases, 5th gear and manual mode are prohibited.

#### Accelerator pedal position sensor

- If there is a malfunction in one of the systems, the accelerator opening angle is controlled by ECM according to a pre-determined accelerator angle to make driving possible. And if there are malfunctions in tow systems, the engine speed is fixed by ECM to a pre-determined engine speed to make driving possible.

#### Throttle position sensor

- If there is a malfunction in one of the systems, the accelerator opening angle is controlled by ECM according to a pre-determined accelerator angle to make driving possible. And if there are malfunctions in tow systems, the accelerator opening angle is controlled by the idle signal sent from the ECM which is based on input indicating either idle condition or off-idle condition (pre-determined accelerator opening) in order to make driving possible.

#### PNP switch

- In the unlikely event that a malfunction signal enters the TCM, the position indicator is switched “OFF”, the starter relay is switched “OFF” (starter starting is disabled), the back-up lamp relay switched “OFF” (back-up lamp is OFF) and the position is fixed to the “D” range to make driving possible.

#### Starter relay

- The starter relay is switched “OFF”. (Starter starting is disabled.)

## A/T Interlock

- If there is an A/T interlock judgment malfunction, the transmission is fixed in 2nd gear, 4th gear, or 5th gear to make driving possible.

**NOTE:**

**When the vehicle is driven fixed in 2nd gear or 5th gear, a turbine revolution sensor malfunction is displayed, but this is not a turbine revolution sensor malfunction.**

- When the coupling pattern below is detected, the fail-safe action corresponding to the pattern is executed.

### A/T INTERLOCK COUPLING PATTERN TABLE

●: NG X: OK

Gear position		ATF pressure switch output					Fail-safe function	Clutch pressure output pattern after fail-safe function					
		SW3 (I/C)	SW6 (H&LR /C)	SW5 (D/C)	SW1 (FR/B)	SW2 (LC/B)		I/C	H&LR/C	D/C	FR/B	LC/B	L/U
A/T interlock coupling pattern	1st	●	X	–	X	X	Held in 4th gear	ON	ON	ON	OFF	OFF	OFF
		–	X	●	–	X	Held in 4th gear	ON	ON	ON	OFF	OFF	OFF
	2nd	–	●	X	–	X	Held in 4th gear	ON	ON	ON	OFF	OFF	OFF
		●	–	X	X	–	Held in 4th gear	ON	ON	ON	OFF	OFF	OFF
	3rd	–	X	X	–	●	Held in 2nd gear	OFF	OFF	ON	OFF	OFF	OFF
		●	–	X	X	–	Held in 4th gear	ON	ON	ON	OFF	OFF	OFF
	4th	–	X	X	–	●	Held in 2nd gear	OFF	OFF	ON	OFF	OFF	OFF
		X	–	X	●	–	Held in 5th gear	ON	ON	OFF	ON	OFF	OFF
	5th	X	X	–	X	●	Held in 2nd gear	OFF	OFF	ON	OFF	OFF	OFF
		X	–	●	X	–	Held in 4th gear	ON	ON	ON	OFF	OFF	OFF

## A/T 1st engine braking

- When there is an A/T first gear engine brake judgment malfunction, the low coast brake solenoid is switched “OFF” to avoid the engine brake operation.

## Line pressure solenoid

- The solenoid is switched “OFF” and the line pressure is set to the maximum hydraulic pressure to make driving possible.

## Torque converter clutch solenoid

- The solenoid is switched “OFF” to release the lock-up.

## Low coast brake solenoid

- When a (electrical or functional) malfunction occurs, in order to make driving possible, if the solenoid is “ON”, the transmission is held in 2nd gear; if the solenoid is “OFF”, the transmission is held in 4th gear. (engine brake is not applied in 1st and 2nd gear.)

## Input clutch solenoid

- If a (electrical or functional) malfunction occurs with the solenoid either “ON” or “OFF”, the transmission is held in 4th gear to make driving possible.

## Direct clutch solenoid

- If a (electrical or functional) malfunction occurs with the solenoid either “ON” or “OFF”, the transmission is held in 4th gear to make driving possible.



### Front brake clutch solenoid

- If a (electrical or functional) malfunction occurs with the solenoid "ON", in order to make driving possible, the A/T is held in 5th gear; if the solenoid is OFF, 4th gear.

### High and low reverse clutch solenoid

- If a (electrical or functional) malfunction occurs with the solenoid either "ON" or "OFF", the transmission is held in 4th gear to make driving possible.

### Turbine revolution sensor 1 or 2

- The control is the same as if there were no turbine revolution sensors, 5th gear and manual mode are prohibited.

## How To Perform Trouble Diagnosis For Quick and Accurate Repair

AC.S000HK

The TCM receives a signal from the vehicle speed sensor, accelerator pedal position sensor (throttle position sensor) or PNP switch and provides shift control or lock-up control via A/T solenoid valves.

The TCM also communicates with the ECM by means of a signal sent from sensing elements used with the OBD-related parts of the A/T system for malfunction-diagnostic purposes. The TCM is capable of diagnosing malfunctioning parts while the ECM can store malfunctions in its memory.

Input and output signals must always be correct and stable in the operation of the A/T system. The A/T system must be in good operating condition and be free of valve seizure, solenoid valve malfunction, etc.

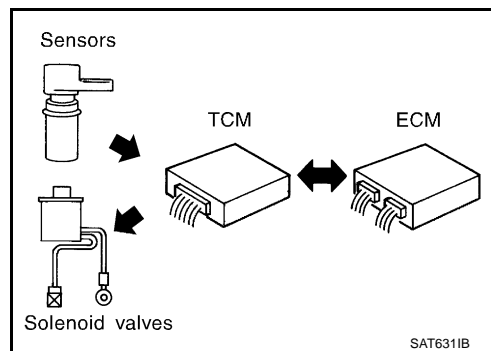

It is much more difficult to diagnose a error that occurs intermittently rather than continuously. Most intermittent errors are caused by poor electric connections or improper wiring. In this case, careful checking of suspected circuits may help prevent the replacement of good parts.

A visual check only may not find the cause of the errors. A road test with CONSULT-II (or GST) or a circuit tester connected should be performed. Follow the [AT-42, "WORK FLOW"](#) .

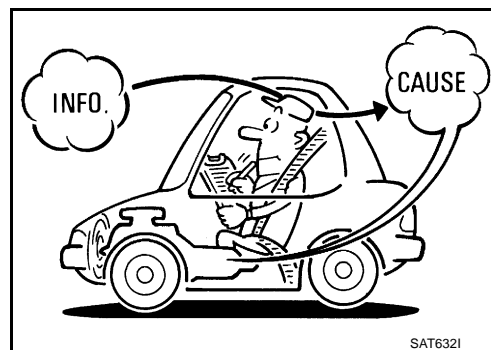

Before undertaking actual checks, take a few minutes to talk with a customer who approaches with a driveability complaint. The customer can supply good information about such errors, especially intermittent ones. Find out what symptoms are present and under what conditions they occur. A "Diagnostic Worksheet" as shown on the example (Refer to [AT-43](#) ) should be used.

Start your diagnosis by looking for "conventional" errors first. This will help troubleshoot driveability errors on an electronically controlled engine vehicle.

Also check related Service bulletins.

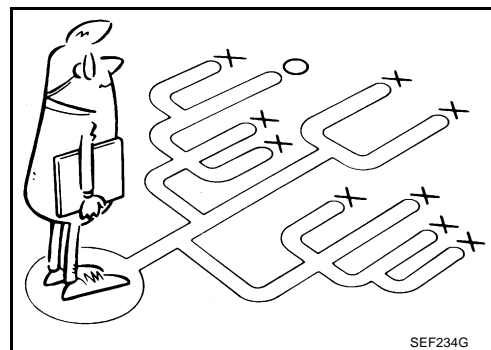

## WORK FLOW

A good understanding of the malfunction conditions can make troubleshooting faster and more accurate. In general, each customer feels differently about a malfunction. It is important to fully understand the symptoms or conditions for a customer complaint.

Make good use of the two sheets provided, "Information From Customer" (Refer to [AT-43](#)) and "Diagnostic Worksheet" (Refer to [AT-43](#)), to perform the best troubleshooting possible.

### Work flow chart

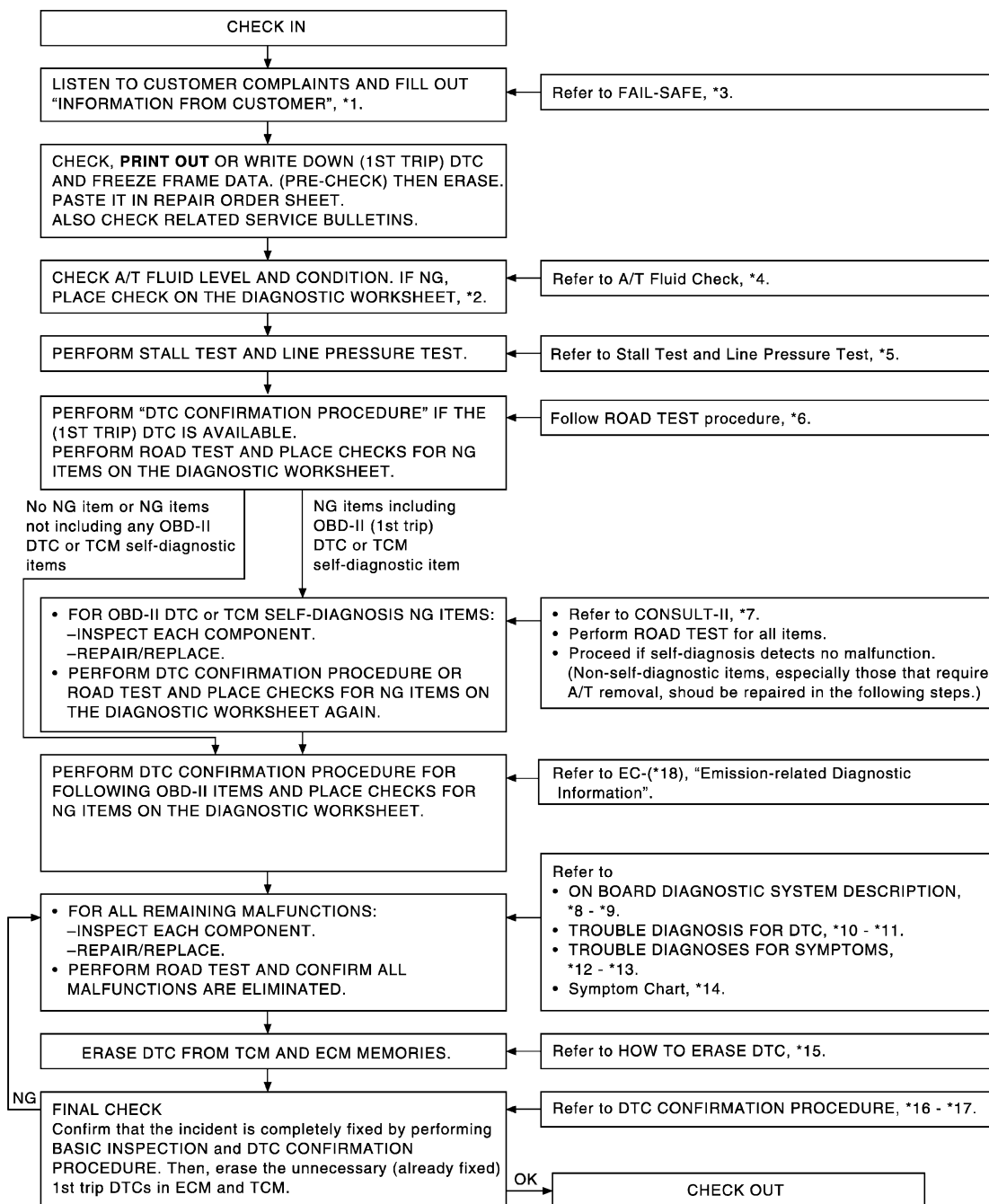

SCIA0501E

\*1. [AT-43](#)

\*2. [AT-43](#)

\*3. [AT-39](#)

\*4. [AT-55](#)

\*5. [AT-55](#), [AT-57](#)

\*6. [AT-59](#)

\*7. [AT-75](#)

\*8. [AT-35](#)

\*9. [AT-87](#)

\*10. [AT-89](#)

\*11. [AT-94](#), [AT-145](#), [AT-158](#), [AT-112](#)

\*12. [AT-159](#)

\*13. [AT-179](#)

\*14. [AT-65](#)

\*15. [AT-36](#)

\*16. [AT-89](#)

\*17. [AT-155](#)

\*18. [EC-47](#)

### DIAGNOSTIC WORKSHEET

#### Information from customer

#### KEY POINTS

- **WHAT.....** Vehicle & A/T model
- **WHEN.....** Date, Frequencies
- **WHERE.....** Road conditions
- **HOW.....** Operating conditions, Symptoms

Customer name MR/MS	Model & Year	VIN
Trans. Model	Engine	Mileage
Incident Date	Manuf. Date	In Service Date
Frequency	<input type="checkbox"/> Continuous <input type="checkbox"/> Intermittent ( times a day)	
Symptoms	<input type="checkbox"/> Vehicle does not move. ( <input type="checkbox"/> Any position <input type="checkbox"/> Particular position)	
	<input type="checkbox"/> No up-shift ( <input type="checkbox"/> 1st → 2nd <input type="checkbox"/> 2nd → 3rd <input type="checkbox"/> 3rd → 4th <input type="checkbox"/> 4th → 5th)	
	<input type="checkbox"/> No down-shift ( <input type="checkbox"/> 5th → 4th <input type="checkbox"/> 4th → 3rd <input type="checkbox"/> 3rd → 2nd <input type="checkbox"/> 2nd → 1st)	
	<input type="checkbox"/> Lock-up malfunction	
	<input type="checkbox"/> Shift point too high or too low.	
	<input type="checkbox"/> Shift shock or slip ( <input type="checkbox"/> N → D <input type="checkbox"/> Lock-up <input type="checkbox"/> Any drive position)	
	<input type="checkbox"/> Noise or vibration	
	<input type="checkbox"/> No kick down	
	<input type="checkbox"/> No pattern select	
A/T CHECK indicator lamp	Blinks for about 8 seconds.	
	<input type="checkbox"/> Continuously lit	<input type="checkbox"/> Not lit
Malfunction indicator lamp (MIL)	<input type="checkbox"/> Continuously lit	<input type="checkbox"/> Not lit

#### Diagnostic worksheet chart

1	<input type="checkbox"/> Read the item on "cautions concerning fail-safe and understand the customer's complaint."	<a href="#">AT-39</a>
2	<input type="checkbox"/> A/T fluid inspection	
	<input type="checkbox"/> Leak (Repair leak location.) <input type="checkbox"/> State <input type="checkbox"/> Amount	<a href="#">AT-55</a>
3	<input type="checkbox"/> Stall test and line pressure test	
	<input type="checkbox"/> Stall test	
	<input type="checkbox"/> Torque converter one-way clutch <input type="checkbox"/> Front brake <input type="checkbox"/> high and low reverse clutch <input type="checkbox"/> Low coast brake <input type="checkbox"/> Forward brake <input type="checkbox"/> Reverse brake <input type="checkbox"/> Forward one-way clutch	<input type="checkbox"/> 1st one-way clutch <input type="checkbox"/> 3rd one-way clutch <input type="checkbox"/> Engine <input type="checkbox"/> Line pressure low <input type="checkbox"/> Except for input clutch and direct clutch, clutches and brakes OK
	<input type="checkbox"/> Line pressure inspection - Suspected part:	<a href="#">AT-55, AT-57</a>

	<input type="checkbox"/> Execute all road tests and enter checks in required inspection items.	<a href="#">AT-59</a>									
4	4-1. <table border="1" style="width: 100%; border-collapse: collapse;"> <tr> <td style="width: 15%;"></td> <td>Check before engine is started</td> <td style="width: 10%;"></td> </tr> <tr> <td></td> <td> <input type="checkbox"/> The A/T CHECK Indicator Lamp does come on. <a href="#">AT-159</a> .  <input type="checkbox"/> Execute self-diagnostics Enter checks for detected items.                 </td> <td style="text-align: right;"><a href="#">AT-59</a></td> </tr> <tr> <td></td> <td> <input type="checkbox"/> Vehicle speed sensor-A/T. <a href="#">AT-96</a> .  <input type="checkbox"/> Vehicle speed sensor-MTR. <a href="#">AT-118</a> .  <input type="checkbox"/> Direct clutch solenoid valve. <a href="#">AT-133</a> , <a href="#">AT-135</a> .  <input type="checkbox"/> TCC solenoid valve. <a href="#">AT-100</a> , <a href="#">AT-102</a> .  <input type="checkbox"/> Line pressure solenoid valve. <a href="#">AT-104</a> .  <input type="checkbox"/> Input clutch solenoid valve. <a href="#">AT-125</a> , <a href="#">AT-127</a> .  <input type="checkbox"/> Front brake solenoid valve. <a href="#">AT-129</a> , <a href="#">AT-131</a> .  <input type="checkbox"/> Low coast brake solenoid valve. <a href="#">AT-141</a> , <a href="#">AT-143</a> .  <input type="checkbox"/> high and low reverse clutch solenoid valve. <a href="#">AT-137</a> , <a href="#">AT-139</a> .  <input type="checkbox"/> PNP switch. <a href="#">AT-94</a> .  <input type="checkbox"/> A/T fluid temperature sensors 1, 2. <a href="#">AT-114</a> .  <input type="checkbox"/> Turbine revolution sensors 1, 2. <a href="#">AT-116</a> .  <input type="checkbox"/> A/T interlock. <a href="#">AT-120</a> .  <input type="checkbox"/> A/T 1st engine braking. <a href="#">AT-123</a> .  <input type="checkbox"/> Start signal. <a href="#">AT-91</a> .  <input type="checkbox"/> Accelerator pedal position signal. <a href="#">AT-112</a> .  <input type="checkbox"/> Engine speed signal. <a href="#">AT-98</a> .  <input type="checkbox"/> CAN communication. <a href="#">AT-89</a> .  <input type="checkbox"/> TCM power supply. <a href="#">AT-106</a> .  <input type="checkbox"/> TCM-RAM. <a href="#">AT-109</a> .  <input type="checkbox"/> TCM-ROM. <a href="#">AT-110</a> .  <input type="checkbox"/> TCM-EEPROM. <a href="#">AT-111</a> .  <input type="checkbox"/> Manual mode switch. <a href="#">AT-145</a> .  <input type="checkbox"/> ATF pressure switch1, 3, 5, 6. <a href="#">AT-149</a> , <a href="#">AT-151</a> , <a href="#">AT-153</a> , <a href="#">AT-155</a> .                 </td> <td></td> </tr> </table>		Check before engine is started			<input type="checkbox"/> The A/T CHECK Indicator Lamp does come on. <a href="#">AT-159</a> . <input type="checkbox"/> Execute self-diagnostics Enter checks for detected items.	<a href="#">AT-59</a>		<input type="checkbox"/> Vehicle speed sensor-A/T. <a href="#">AT-96</a> . <input type="checkbox"/> Vehicle speed sensor-MTR. <a href="#">AT-118</a> . <input type="checkbox"/> Direct clutch solenoid valve. <a href="#">AT-133</a> , <a href="#">AT-135</a> . <input type="checkbox"/> TCC solenoid valve. <a href="#">AT-100</a> , <a href="#">AT-102</a> . <input type="checkbox"/> Line pressure solenoid valve. <a href="#">AT-104</a> . <input type="checkbox"/> Input clutch solenoid valve. <a href="#">AT-125</a> , <a href="#">AT-127</a> . <input type="checkbox"/> Front brake solenoid valve. <a href="#">AT-129</a> , <a href="#">AT-131</a> . <input type="checkbox"/> Low coast brake solenoid valve. <a href="#">AT-141</a> , <a href="#">AT-143</a> . <input type="checkbox"/> high and low reverse clutch solenoid valve. <a href="#">AT-137</a> , <a href="#">AT-139</a> . <input type="checkbox"/> PNP switch. <a href="#">AT-94</a> . <input type="checkbox"/> A/T fluid temperature sensors 1, 2. <a href="#">AT-114</a> . <input type="checkbox"/> Turbine revolution sensors 1, 2. <a href="#">AT-116</a> . <input type="checkbox"/> A/T interlock. <a href="#">AT-120</a> . <input type="checkbox"/> A/T 1st engine braking. <a href="#">AT-123</a> . <input type="checkbox"/> Start signal. <a href="#">AT-91</a> . <input type="checkbox"/> Accelerator pedal position signal. <a href="#">AT-112</a> . <input type="checkbox"/> Engine speed signal. <a href="#">AT-98</a> . <input type="checkbox"/> CAN communication. <a href="#">AT-89</a> . <input type="checkbox"/> TCM power supply. <a href="#">AT-106</a> . <input type="checkbox"/> TCM-RAM. <a href="#">AT-109</a> . <input type="checkbox"/> TCM-ROM. <a href="#">AT-110</a> . <input type="checkbox"/> TCM-EEPROM. <a href="#">AT-111</a> . <input type="checkbox"/> Manual mode switch. <a href="#">AT-145</a> . <input type="checkbox"/> ATF pressure switch1, 3, 5, 6. <a href="#">AT-149</a> , <a href="#">AT-151</a> , <a href="#">AT-153</a> , <a href="#">AT-155</a> .		
		Check before engine is started									
	<input type="checkbox"/> The A/T CHECK Indicator Lamp does come on. <a href="#">AT-159</a> . <input type="checkbox"/> Execute self-diagnostics Enter checks for detected items.	<a href="#">AT-59</a>									
	<input type="checkbox"/> Vehicle speed sensor-A/T. <a href="#">AT-96</a> . <input type="checkbox"/> Vehicle speed sensor-MTR. <a href="#">AT-118</a> . <input type="checkbox"/> Direct clutch solenoid valve. <a href="#">AT-133</a> , <a href="#">AT-135</a> . <input type="checkbox"/> TCC solenoid valve. <a href="#">AT-100</a> , <a href="#">AT-102</a> . <input type="checkbox"/> Line pressure solenoid valve. <a href="#">AT-104</a> . <input type="checkbox"/> Input clutch solenoid valve. <a href="#">AT-125</a> , <a href="#">AT-127</a> . <input type="checkbox"/> Front brake solenoid valve. <a href="#">AT-129</a> , <a href="#">AT-131</a> . <input type="checkbox"/> Low coast brake solenoid valve. <a href="#">AT-141</a> , <a href="#">AT-143</a> . <input type="checkbox"/> high and low reverse clutch solenoid valve. <a href="#">AT-137</a> , <a href="#">AT-139</a> . <input type="checkbox"/> PNP switch. <a href="#">AT-94</a> . <input type="checkbox"/> A/T fluid temperature sensors 1, 2. <a href="#">AT-114</a> . <input type="checkbox"/> Turbine revolution sensors 1, 2. <a href="#">AT-116</a> . <input type="checkbox"/> A/T interlock. <a href="#">AT-120</a> . <input type="checkbox"/> A/T 1st engine braking. <a href="#">AT-123</a> . <input type="checkbox"/> Start signal. <a href="#">AT-91</a> . <input type="checkbox"/> Accelerator pedal position signal. <a href="#">AT-112</a> . <input type="checkbox"/> Engine speed signal. <a href="#">AT-98</a> . <input type="checkbox"/> CAN communication. <a href="#">AT-89</a> . <input type="checkbox"/> TCM power supply. <a href="#">AT-106</a> . <input type="checkbox"/> TCM-RAM. <a href="#">AT-109</a> . <input type="checkbox"/> TCM-ROM. <a href="#">AT-110</a> . <input type="checkbox"/> TCM-EEPROM. <a href="#">AT-111</a> . <input type="checkbox"/> Manual mode switch. <a href="#">AT-145</a> . <input type="checkbox"/> ATF pressure switch1, 3, 5, 6. <a href="#">AT-149</a> , <a href="#">AT-151</a> , <a href="#">AT-153</a> , <a href="#">AT-155</a> .										
4-2.	Idle inspection <table border="1" style="width: 100%; border-collapse: collapse;"> <tr> <td style="width: 15%;"></td> <td> <input type="checkbox"/> Engine Cannot Be Started in "P" and "N" Position. <a href="#">AT-160</a> .  <input type="checkbox"/> In "P" Position, Vehicle Moves When Pushed. <a href="#">AT-161</a> .  <input type="checkbox"/> In "N" Position Vehicle Moves. <a href="#">AT-162</a> .  <input type="checkbox"/> Large Shock ("N" to "D" Position). <a href="#">AT-163</a> .  <input type="checkbox"/> Vehicle Does Not Creep Backward In "R" Position. <a href="#">AT-164</a> .  <input type="checkbox"/> Vehicle Does Not Creep Forward In "D" Position. <a href="#">AT-165</a> .                 </td> <td style="width: 10%; text-align: right;"><a href="#">AT-59</a></td> </tr> </table>		<input type="checkbox"/> Engine Cannot Be Started in "P" and "N" Position. <a href="#">AT-160</a> . <input type="checkbox"/> In "P" Position, Vehicle Moves When Pushed. <a href="#">AT-161</a> . <input type="checkbox"/> In "N" Position Vehicle Moves. <a href="#">AT-162</a> . <input type="checkbox"/> Large Shock ("N" to "D" Position). <a href="#">AT-163</a> . <input type="checkbox"/> Vehicle Does Not Creep Backward In "R" Position. <a href="#">AT-164</a> . <input type="checkbox"/> Vehicle Does Not Creep Forward In "D" Position. <a href="#">AT-165</a> .	<a href="#">AT-59</a>							
	<input type="checkbox"/> Engine Cannot Be Started in "P" and "N" Position. <a href="#">AT-160</a> . <input type="checkbox"/> In "P" Position, Vehicle Moves When Pushed. <a href="#">AT-161</a> . <input type="checkbox"/> In "N" Position Vehicle Moves. <a href="#">AT-162</a> . <input type="checkbox"/> Large Shock ("N" to "D" Position). <a href="#">AT-163</a> . <input type="checkbox"/> Vehicle Does Not Creep Backward In "R" Position. <a href="#">AT-164</a> . <input type="checkbox"/> Vehicle Does Not Creep Forward In "D" Position. <a href="#">AT-165</a> .	<a href="#">AT-59</a>									
4-3.	Driving tests <table border="1" style="width: 100%; border-collapse: collapse;"> <tr> <td style="width: 15%;"></td> <td>Part 1</td> <td style="width: 10%;"></td> </tr> <tr> <td></td> <td> <input type="checkbox"/> Vehicle Cannot Be Started From D1. <a href="#">AT-166</a> .  <input type="checkbox"/> A/T Does Not Shift: D1 → D2. <a href="#">AT-167</a> .  <input type="checkbox"/> A/T Does Not Shift: D2 → D3. <a href="#">AT-168</a> .  <input type="checkbox"/> A/T Does Not Shift: D3 → D4. <a href="#">AT-169</a> .  <input type="checkbox"/> A/T Does Not Shift: D4 → D5. <a href="#">AT-170</a> .  <input type="checkbox"/> A/T Does Not Perform Lock-up. <a href="#">AT-172</a> .  <input type="checkbox"/> A/T Does Not Hold Lock-up Condition. <a href="#">AT-173</a> .  <input type="checkbox"/> Lock-up Is Not Released. <a href="#">AT-173</a> .  <input type="checkbox"/> Engine Speed Does Not Return To Idle. <a href="#">AT-174</a> .                 </td> <td style="text-align: right;"><a href="#">AT-61</a></td> </tr> </table>		Part 1			<input type="checkbox"/> Vehicle Cannot Be Started From D1. <a href="#">AT-166</a> . <input type="checkbox"/> A/T Does Not Shift: D1 → D2. <a href="#">AT-167</a> . <input type="checkbox"/> A/T Does Not Shift: D2 → D3. <a href="#">AT-168</a> . <input type="checkbox"/> A/T Does Not Shift: D3 → D4. <a href="#">AT-169</a> . <input type="checkbox"/> A/T Does Not Shift: D4 → D5. <a href="#">AT-170</a> . <input type="checkbox"/> A/T Does Not Perform Lock-up. <a href="#">AT-172</a> . <input type="checkbox"/> A/T Does Not Hold Lock-up Condition. <a href="#">AT-173</a> . <input type="checkbox"/> Lock-up Is Not Released. <a href="#">AT-173</a> . <input type="checkbox"/> Engine Speed Does Not Return To Idle. <a href="#">AT-174</a> .	<a href="#">AT-61</a>				
	Part 1										
	<input type="checkbox"/> Vehicle Cannot Be Started From D1. <a href="#">AT-166</a> . <input type="checkbox"/> A/T Does Not Shift: D1 → D2. <a href="#">AT-167</a> . <input type="checkbox"/> A/T Does Not Shift: D2 → D3. <a href="#">AT-168</a> . <input type="checkbox"/> A/T Does Not Shift: D3 → D4. <a href="#">AT-169</a> . <input type="checkbox"/> A/T Does Not Shift: D4 → D5. <a href="#">AT-170</a> . <input type="checkbox"/> A/T Does Not Perform Lock-up. <a href="#">AT-172</a> . <input type="checkbox"/> A/T Does Not Hold Lock-up Condition. <a href="#">AT-173</a> . <input type="checkbox"/> Lock-up Is Not Released. <a href="#">AT-173</a> . <input type="checkbox"/> Engine Speed Does Not Return To Idle. <a href="#">AT-174</a> .	<a href="#">AT-61</a>									

4	4-3	Part 2 <input type="checkbox"/> Vehicle Cannot Be Started From D1. <a href="#">AT-166</a> . <input type="checkbox"/> A/T Does Not Shift: D1 → D2. <a href="#">AT-167</a> . <input type="checkbox"/> A/T Does Not Shift: D2 → D3. <a href="#">AT-168</a> . <input type="checkbox"/> A/T Does Not Shift: D3 → D4. <a href="#">AT-169</a> .	<a href="#">AT-63</a>	A
		Part 3 <input type="checkbox"/> Cannot Be Changed To Manual Mode. <a href="#">AT-175</a> . <input type="checkbox"/> A/T Does Not Shift:5th gear → 4th gear. <a href="#">AT-175</a> . <input type="checkbox"/> A/T Does Not Shift:4th gear → 3rd gear. <a href="#">AT-176</a> . <input type="checkbox"/> A/T Does Not Shift:3rd gear → 2nd gear. <a href="#">AT-177</a> . <input type="checkbox"/> A/T Does Not Shift:2nd gear → 1st gear. <a href="#">AT-178</a> . <input type="checkbox"/> Vehicle Does Not Decelerate By Engine Brake. <a href="#">AT-179</a> . <input type="checkbox"/> Execute self-diagnostics Enter checks for detected items.	<a href="#">AT-64</a>	B <b>AT</b> D
		<input type="checkbox"/> Vehicle speed sensor-A/T. <a href="#">AT-96</a> . <input type="checkbox"/> Vehicle speed sensor-MTR. <a href="#">AT-118</a> . <input type="checkbox"/> Direct clutch solenoid valve. <a href="#">AT-133</a> , <a href="#">AT-135</a> . <input type="checkbox"/> TCC solenoid valve. <a href="#">AT-100</a> , <a href="#">AT-102</a> . <input type="checkbox"/> Line pressure solenoid valve. <a href="#">AT-104</a> . <input type="checkbox"/> Input clutch solenoid valve. <a href="#">AT-125</a> , <a href="#">AT-127</a> . <input type="checkbox"/> Front brake solenoid valve. <a href="#">AT-129</a> , <a href="#">AT-131</a> . <input type="checkbox"/> Low coast brake solenoid valve. <a href="#">AT-141</a> , <a href="#">AT-143</a> . <input type="checkbox"/> high and low reverse clutch solenoid valve. <a href="#">AT-137</a> , <a href="#">AT-139</a> . <input type="checkbox"/> PNP switch. <a href="#">AT-94</a> . <input type="checkbox"/> A/T fluid temperature sensors 1, 2. <a href="#">AT-114</a> . <input type="checkbox"/> Turbine revolution sensors 1, 2. <a href="#">AT-116</a> . <input type="checkbox"/> A/T interlock. <a href="#">AT-120</a> . <input type="checkbox"/> A/T 1st engine braking. <a href="#">AT-123</a> . <input type="checkbox"/> Start signal. <a href="#">AT-91</a> . <input type="checkbox"/> Accelerator pedal position signal. <a href="#">AT-112</a> . <input type="checkbox"/> Engine speed signal. <a href="#">AT-98</a> . <input type="checkbox"/> CAN communication. <a href="#">AT-89</a> . <input type="checkbox"/> TCM power supply. <a href="#">AT-106</a> . <input type="checkbox"/> TCM-RAM. <a href="#">AT-109</a> . <input type="checkbox"/> TCM-ROM. <a href="#">AT-110</a> . <input type="checkbox"/> TCM-EEPROM. <a href="#">AT-111</a> . <input type="checkbox"/> Manual mode switch. <a href="#">AT-145</a> . <input type="checkbox"/> ATF pressure switch1, 3, 5, 6. <a href="#">AT-149</a> , <a href="#">AT-151</a> , <a href="#">AT-153</a> , <a href="#">AT-155</a> .		E F G H I J K
5	<input type="checkbox"/> Inspect each system for items found to be NG in the self-diagnostics and repair or replace the malfunction parts.			
6	<input type="checkbox"/> Execute all road tests and enter the checks again for the required items.	<a href="#">AT-59</a>		L
7	<input type="checkbox"/> For any remaining NG items, execute the “diagnostics procedure” and repair or replace the malfunction parts. See the chart for diagnostics by symptoms. (This chart also contains other symptoms and inspection procedures.)	<a href="#">AT-65</a>		M
8	<input type="checkbox"/> Erase the results of the self-diagnostics from the TCM.	<a href="#">AT-75</a> , <a href="#">AT-87</a>		

**A/T Electrical Parts Location**

ACS000HL

**COUPE MODEL**

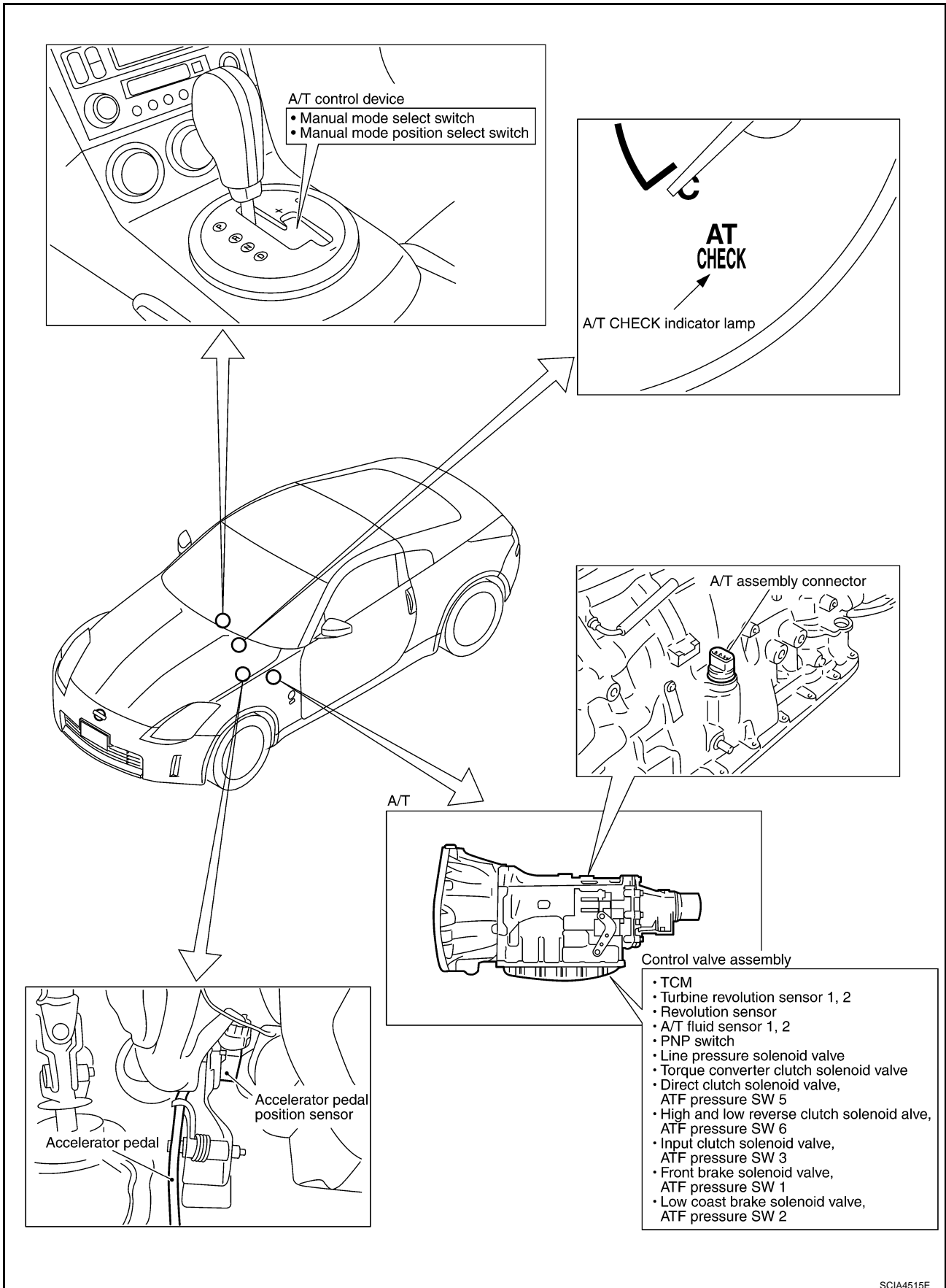

SCIA4515E

ROADSTER MODEL

A  
 B  
**AT**  
 D  
 E  
 F  
 G  
 H  
 I  
 J  
 K  
 L  
 M

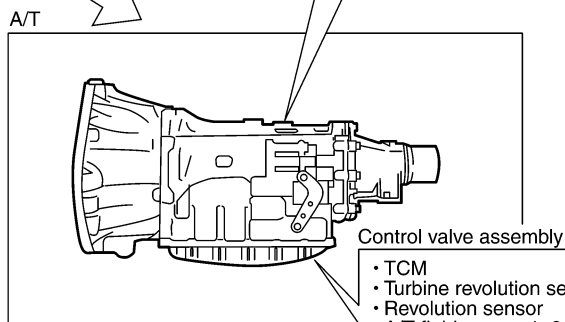
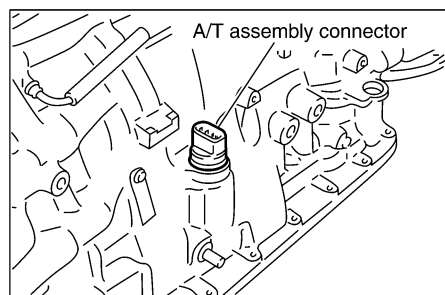
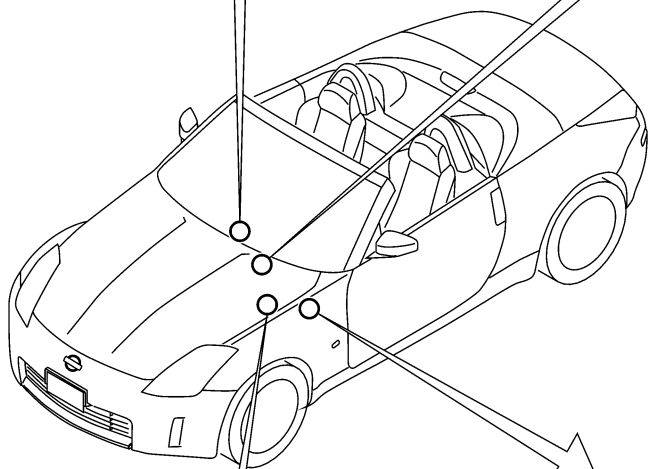
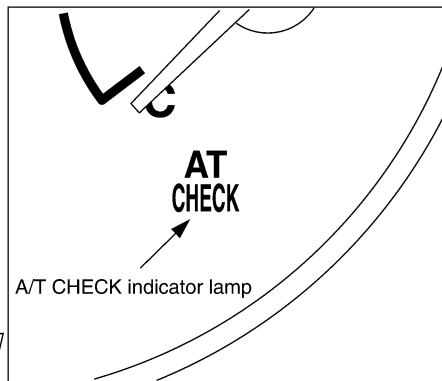
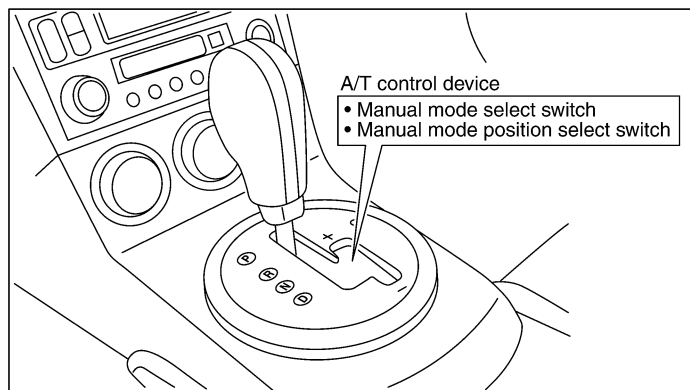

- TCM
- Turbine revolution sensor 1, 2
- Revolution sensor
- A/T fluid sensor 1, 2
- PNP switch
- Line pressure solenoid valve
- Torque converter clutch solenoid valve
- Direct clutch solenoid valve, ATF pressure SW 5
- High and low reverse clutch solenoid valve, ATF pressure SW 6
- Input clutch solenoid valve, ATF pressure SW 3
- Front brake solenoid valve, ATF pressure SW 1
- Low coast brake solenoid valve, ATF pressure SW 2

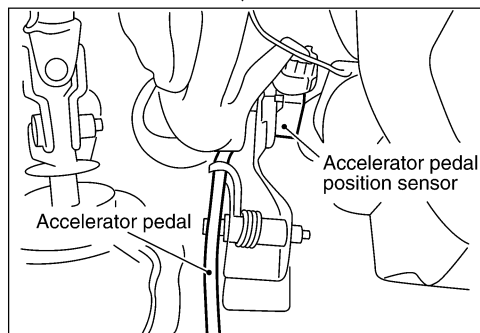

**Circuit Diagram**

ACS000HM

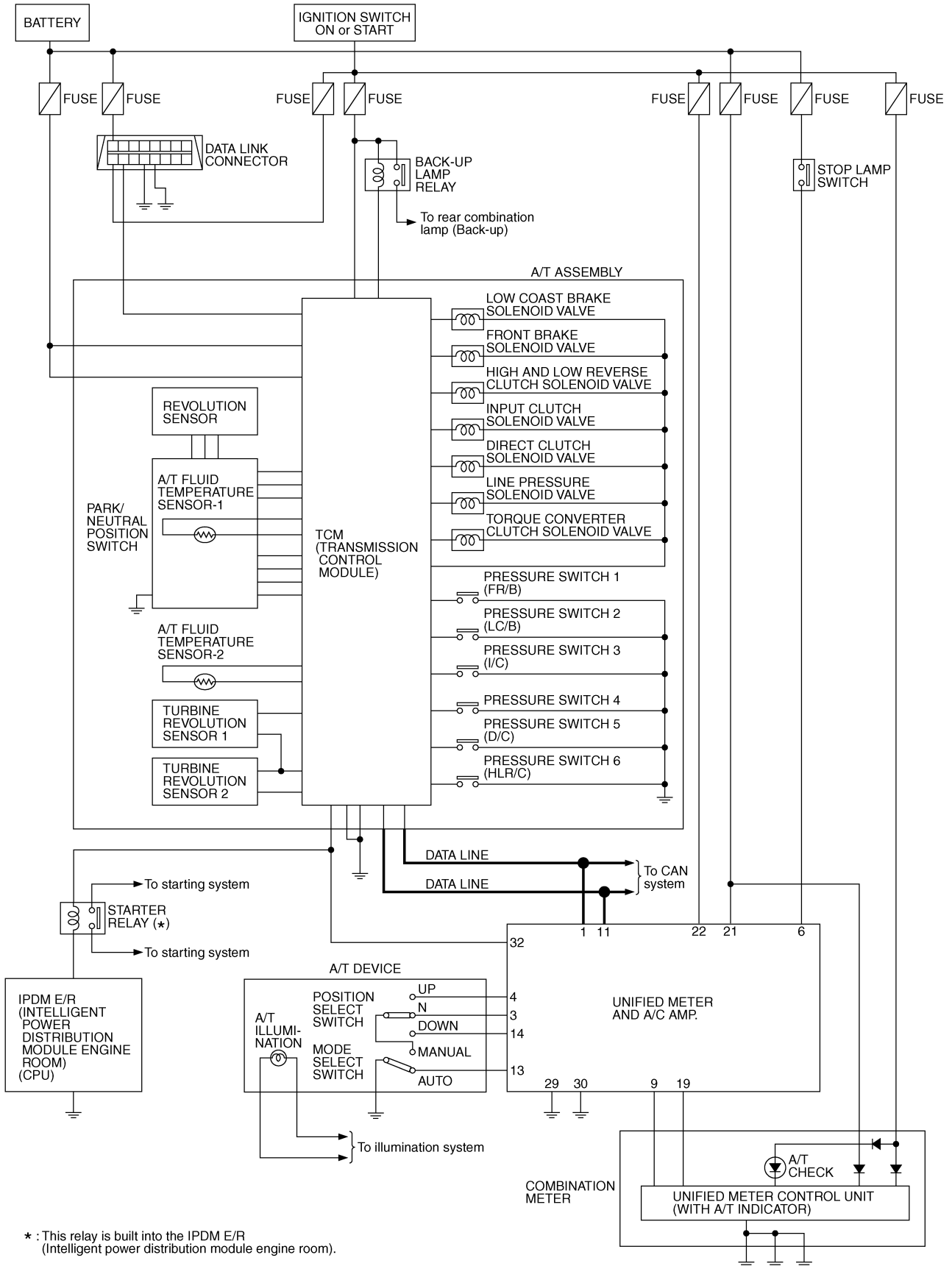

\* : This relay is built into the IPDM E/R (Intelligent power distribution module engine room).

TCWT0089E



Wiring Diagram — AT —

ACS001LH

AT-A/T-01

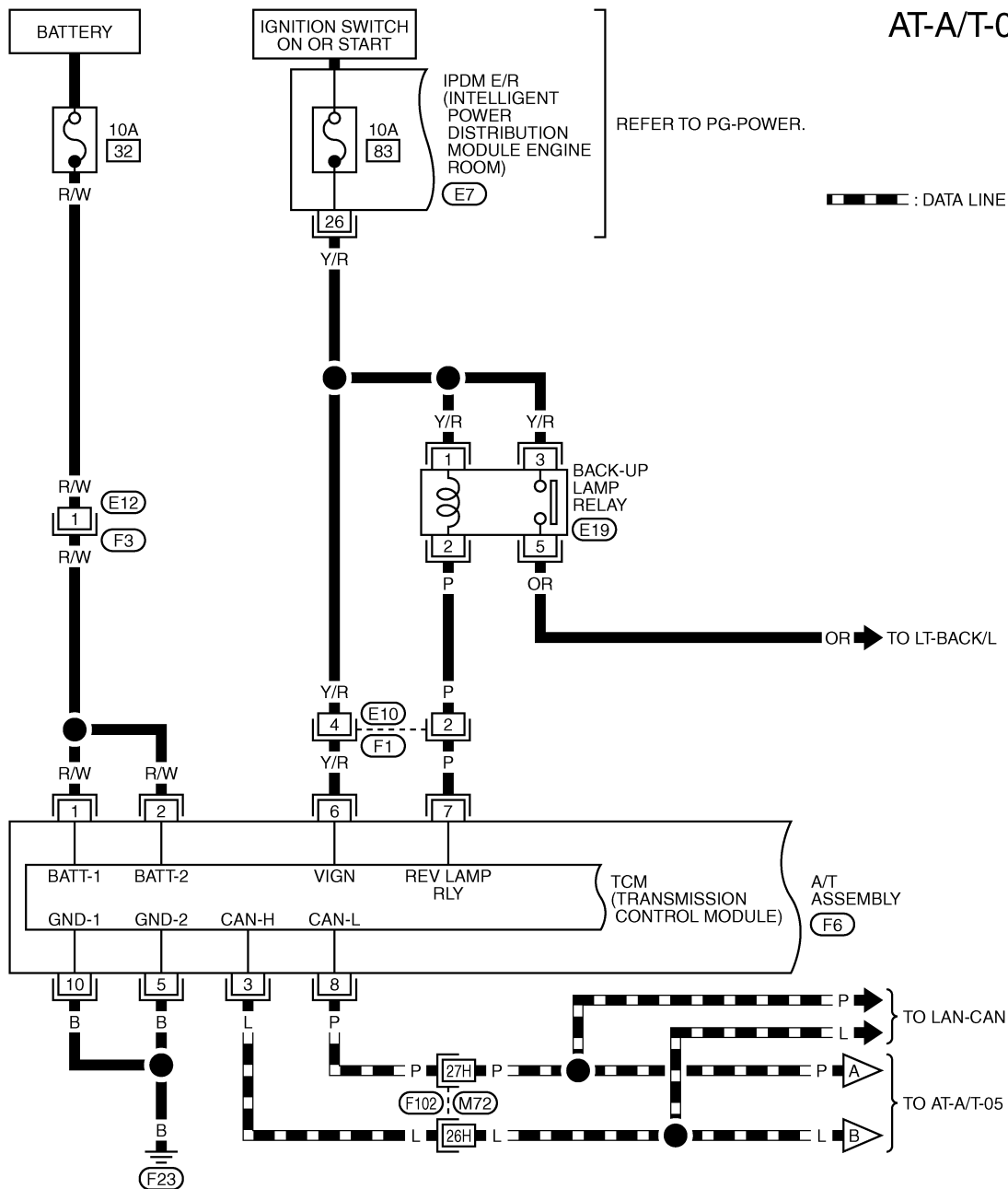

A  
B  
AT  
D  
E  
F  
G  
H  
I  
J  
K  
L  
M

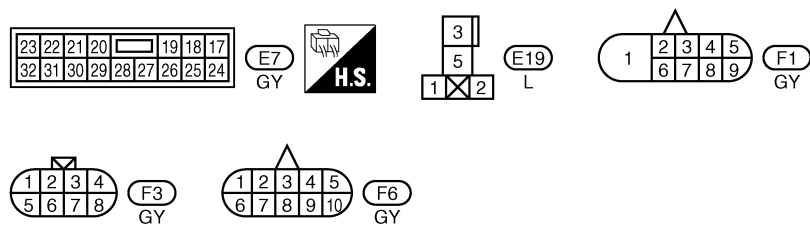

REFER TO THE FOLLOWING.  
F102 -SUPER MULTIPLE JUNCTION (SMJ)

AT-A/T-02

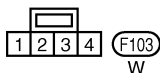
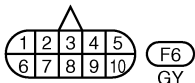
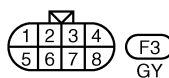
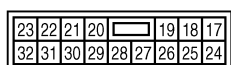
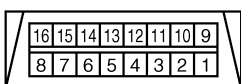
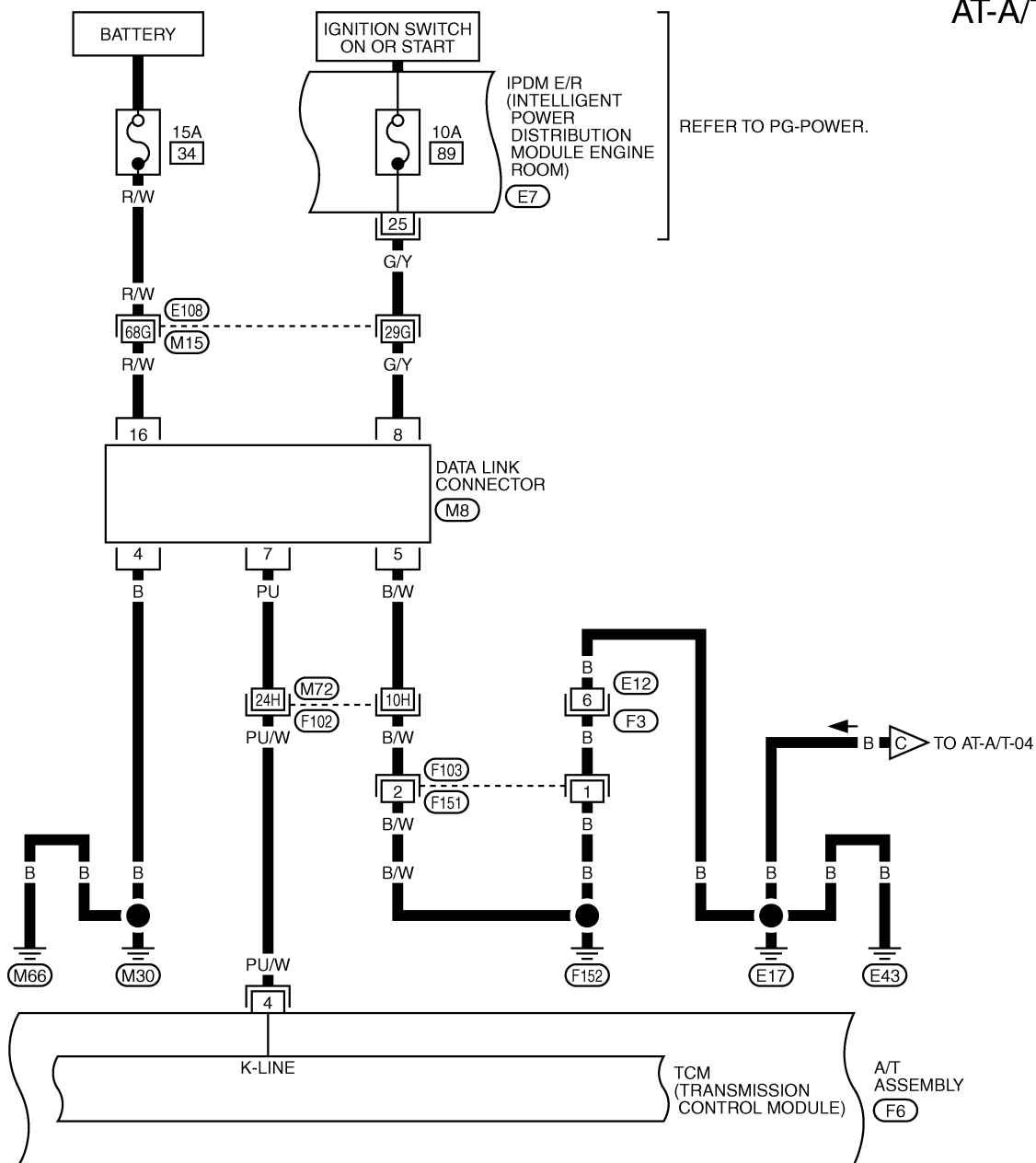

REFER TO THE FOLLOWING.  
 (E108), (F102) -SUPER MULTIPLE JUNCTION (SMJ)

AT-A/T-03

A  
 B  
**AT**  
 D  
 E  
 F  
 G  
 H  
 I  
 J  
 K  
 L  
 M

AT ASSEMBLY

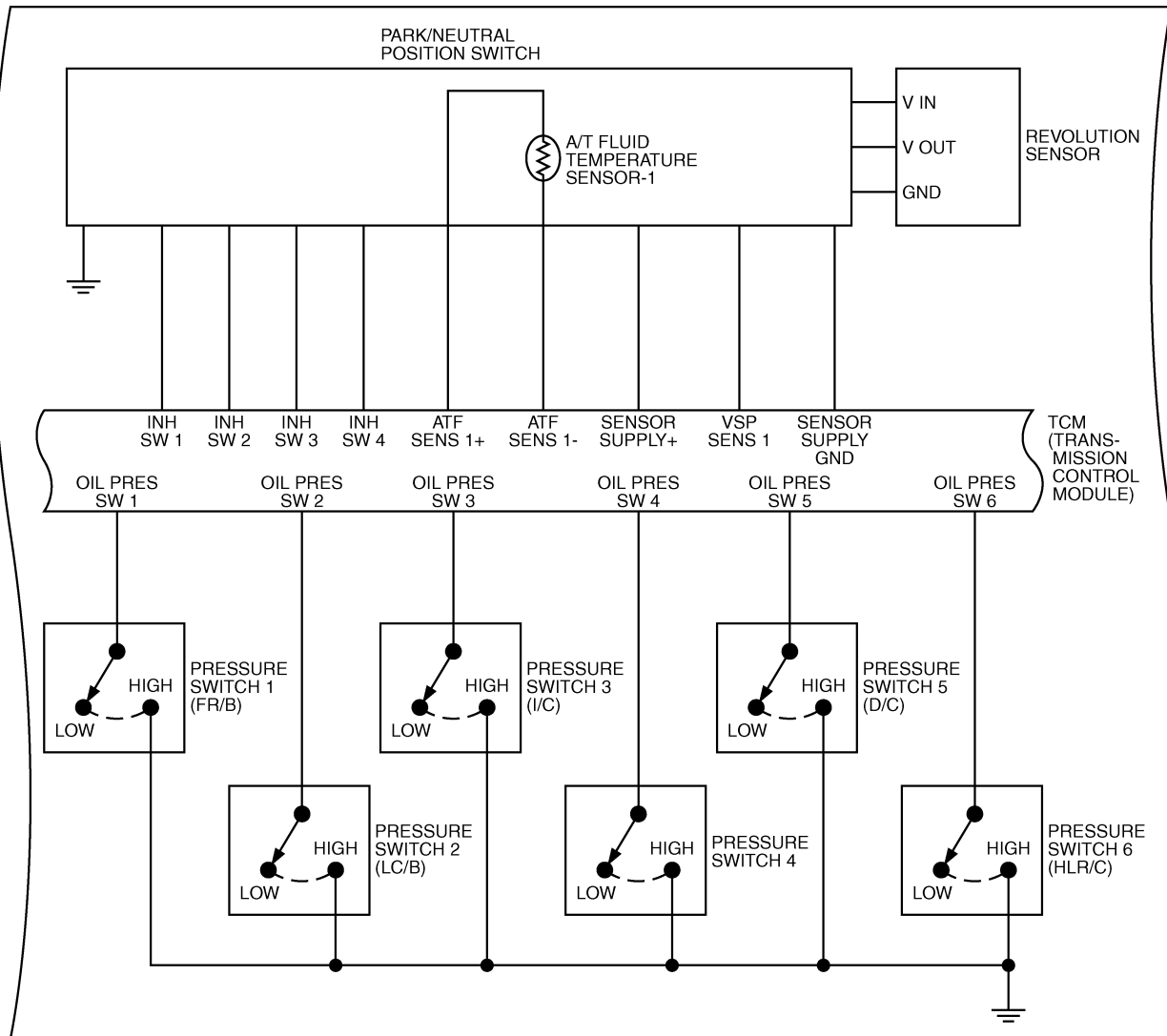

TCWT0091E

AT-A/T-04

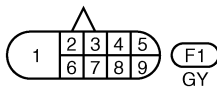
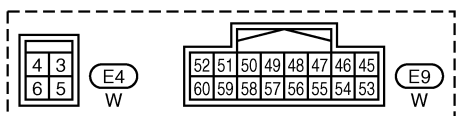
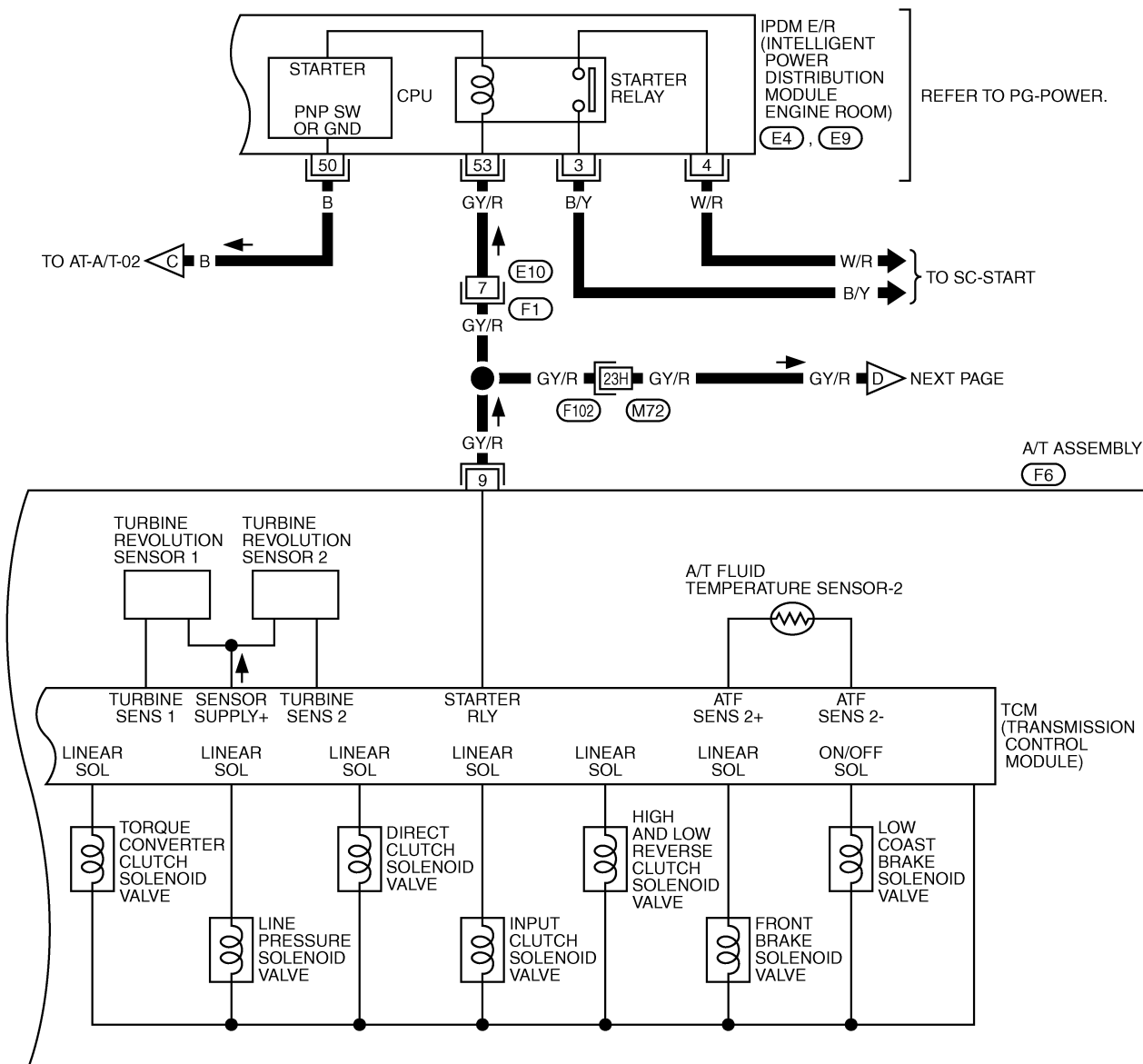

REFER TO THE FOLLOWING.  
 (F102) -SUPER MULTIPLE JUNCTION (SMJ)

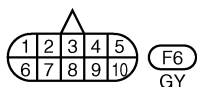

## AT-A/T-05

▬ : DATA LINE

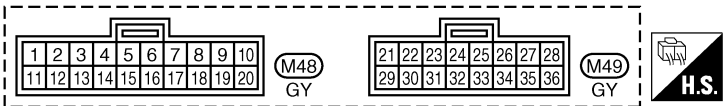
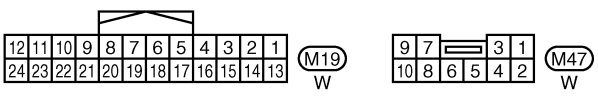
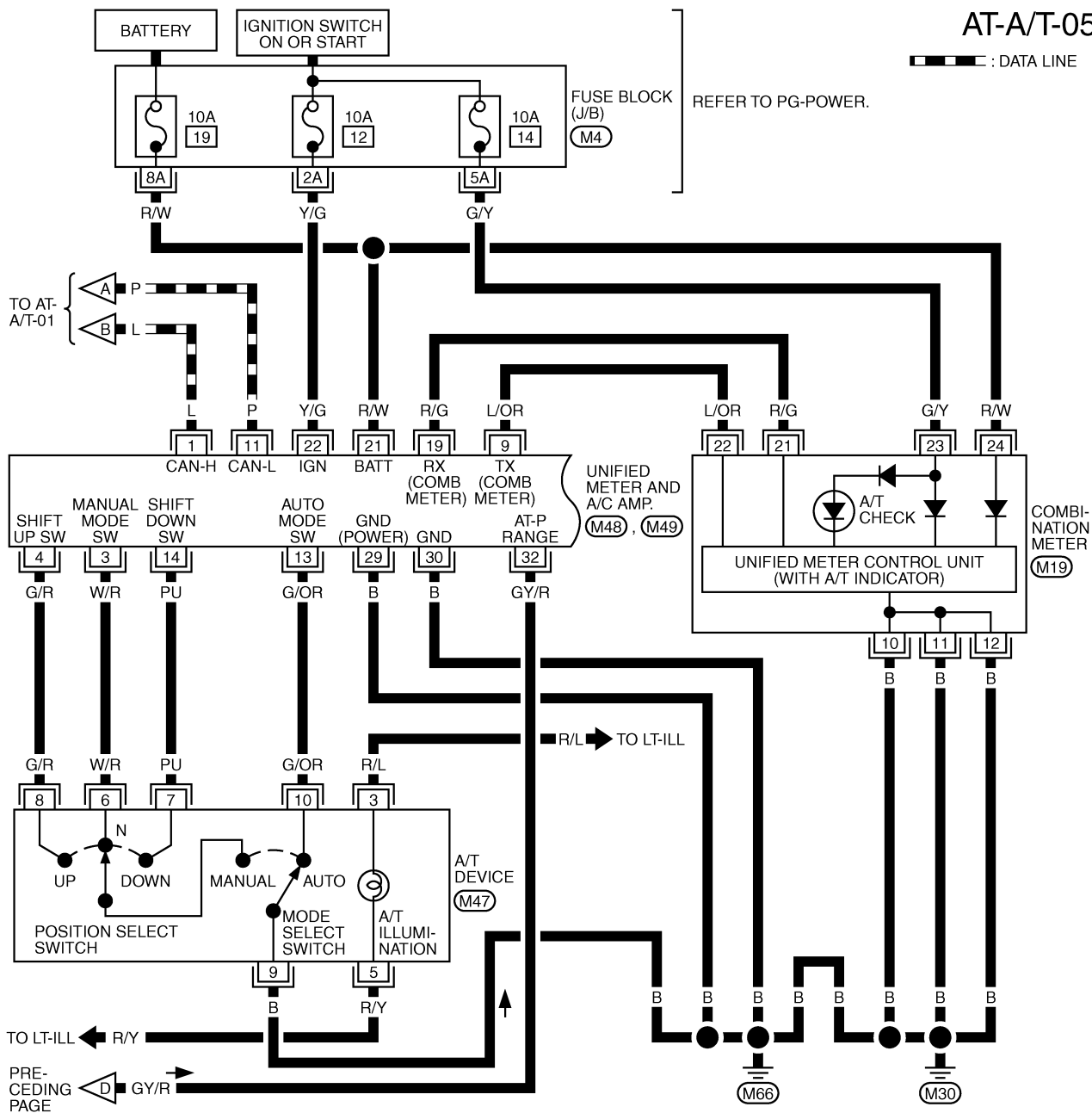

REFER TO THE FOLLOWING.  
 (M4) - FUSE BLOCK-JUNCTION BOX (J/B)

A  
B  
**AT**  
D  
E  
F  
G  
H  
I  
J  
K  
L  
M

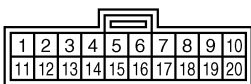
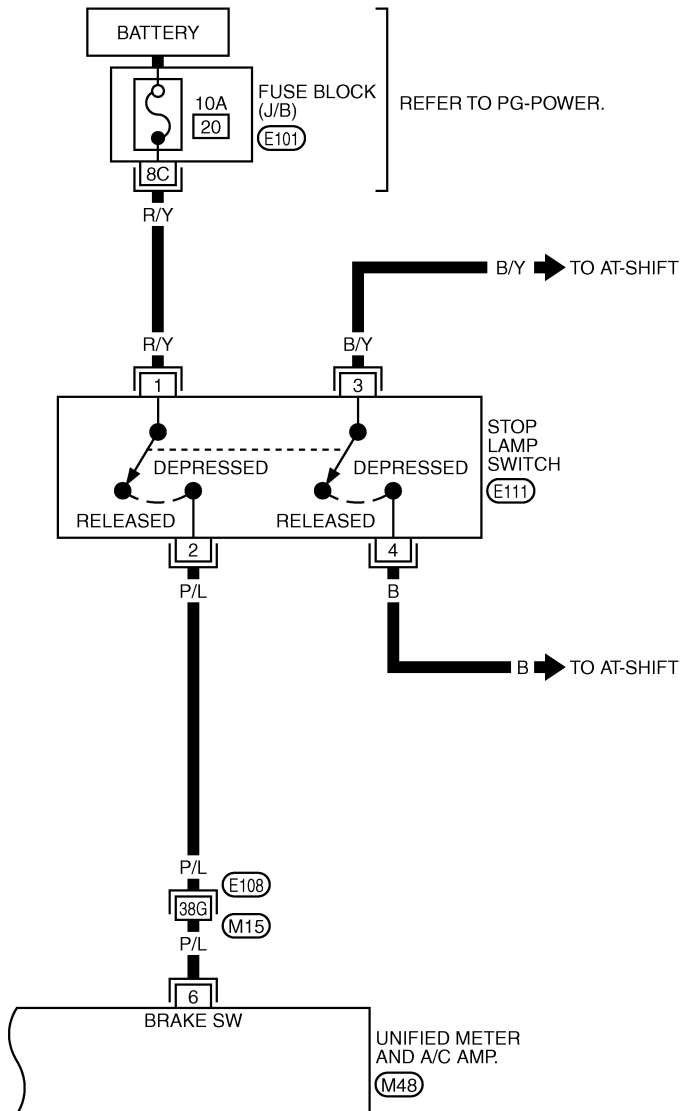

(M48)  
GY

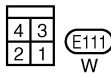





(E111)  
W

REFER TO THE FOLLOWING.

(E108) -SUPER MULTIPLE JUNCTION (SMJ)

(E101) -FUSE BLOCK-JUNCTION BOX (J/B)

TCM terminals and data are reference value. Measured between each terminal and ground.

Terminal No.	Wire color	Item	Condition	Data (Approx.)
1	R/W	Power supply (Memory back-up)	Always	Battery voltage
2	R/W	Power supply (Memory back-up)	Always	Battery voltage
3	L	CAN-H	-	-
4	PU/W	K-line (CONSULT-II signal)	The terminal is connected to the data link connector for CONSULT-II.	
5	B	Ground	-	-
6	Y/R	Power supply		Battery voltage
				0V
7	P	Back-up lamp relay		0V
				Battery voltage
8	P	CAN-L	-	-
9	GY/R	Starter relay		Battery voltage
				0V
10	B	Ground	-	-

## Inspections Before Trouble Diagnosis

### A/T FLUID CHECK

ACS000HN

#### Fluid leakage and fluid level check

- Inspect for fluid leakage and check the fluid level. Refer to [AT-10, "Checking A/T Fluid"](#).

#### Fluid condition check

Inspect the fluid condition.

Fluid condition	Conceivable Cause	Required Operation
Varnished (viscous varnish state)	Clutch, brake scorched	Replace the A/T fluid and check the A/T main unit and the vehicle for malfunctions (wire harnesses, cooler pipes, etc.)
Milky white or cloudy	Water in the fluid	Replace the A/T fluid and check for places where water is getting in.
Large amount of metal powder mixed in	Unusual wear of sliding parts within A/T	Replace the A/T fluid and check for improper operation of the A/T.

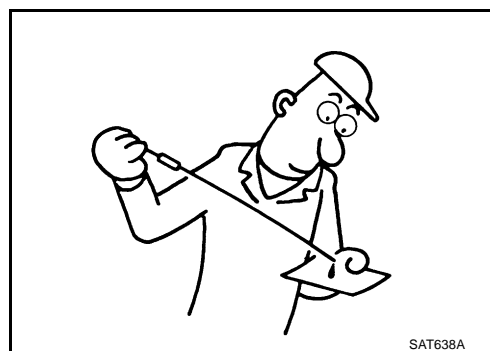

### STALL TEST

#### Stall test procedure

1. Inspect the amount of engine oil. Replenish the engine oil if necessary.

- Drive for about 10 minutes to warm up the vehicle so that the A/T fluid temperature is 50 to 80°C (122 to 176°F). Inspect the amount of A/T fluid. Replenish if necessary.

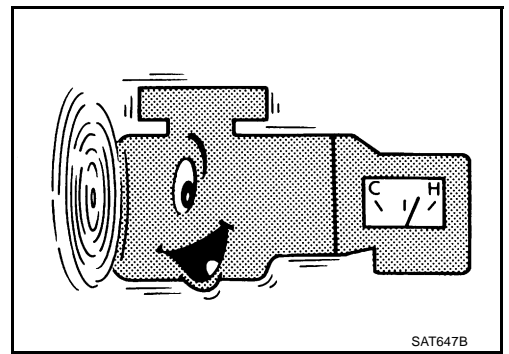

- Securely engage the parking brake so that the tires do not turn.

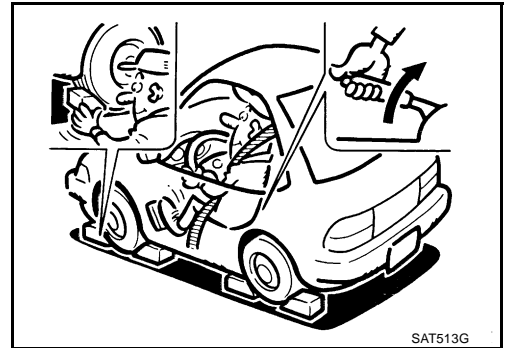

- Engine start, apply foot brake, and place selector lever in "D" position.
- While holding down the foot brake, gradually press down the accelerator pedal.
- Quickly read off the stall speed, then quickly remove your foot from the accelerator pedal.

**CAUTION:**

**Do not hold down the accelerator pedal for more than 5 seconds during this test.**

- Move the selector lever to the "N" position.
- Cool down the A/T fluid.

**CAUTION:**

**Run the engine at idle for at least one minute.**

**Stall speed: 2,650 - 2,950 rpm**

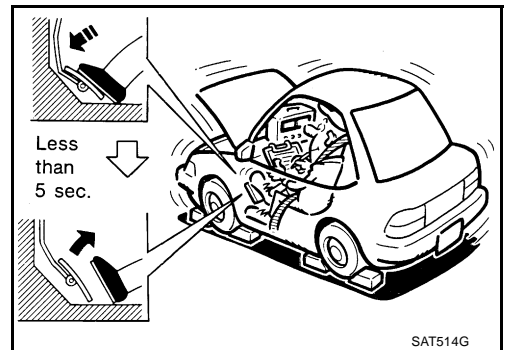

**Judgement stall test**

	Selector lever position		Expected problem location
	D, M	R	
Stall rotation	H	O	<ul style="list-style-type: none"> <li>● Forward brake</li> <li>● Forward one-way clutch</li> <li>● 1st one-way clutch</li> <li>● 3rd one-way clutch</li> </ul>
	O	H	<ul style="list-style-type: none"> <li>● Reverse clutch</li> </ul>
	L	L	<ul style="list-style-type: none"> <li>● Engine and torque converter one-way clutch</li> </ul>
	H	H	<ul style="list-style-type: none"> <li>● Line pressure low</li> </ul>
	O	O	<ul style="list-style-type: none"> <li>● One-way clutch in torque converter stuck or check with another item tests</li> </ul>

O: Stall speed within standard value position

H: Stall speed higher than standard value

L: Stall speed lower than standard value



## Stall test standard value position

Does not shift up D, M position 1 → 2	Slipping in 2nd, 3rd, 4th gears	Direct clutch slippage
Does not shift up D, M position 2 → 3	Slipping in 3rd, 4th, 5th gears	high and low reverse clutch slippage
Does not shift up D, M position 3 → 4	Slipping in 4th, 5th gears	Input clutch slippage
Does not shift up D, M position 4 → 5	Slipping in 5th gear	Front brake slippage

## LINE PRESSURE TEST

### Line pressure test port

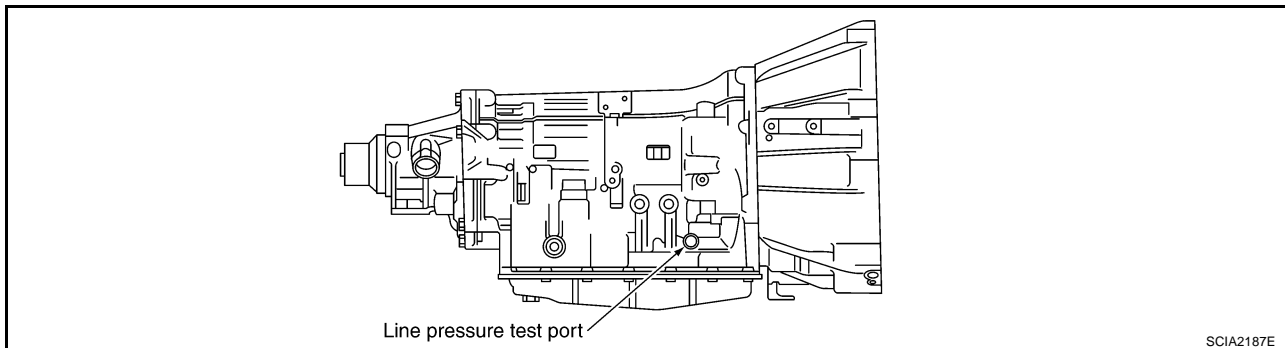

### Line pressure test procedure

1. Inspect the amount of engine oil and replenish if necessary.
2. Drive the car for about 10 minutes to warm it up so that the A/T fluid reaches in range of 50 to 80°C (122 to 176°F), then inspect the amount of A/T fluid and replenish if necessary.

**NOTE:**

**The A/T fluid temperature rises in range of 50 to 80°C (122 to 176°F) during 10 minutes of driving.**

3. After warming up remove the oil pressure detection plug and install the oil pressure gauge.

**CAUTION:**

**When using the oil pressure gauge, be sure to use the O-ring attached to the oil pressure detection plug.**

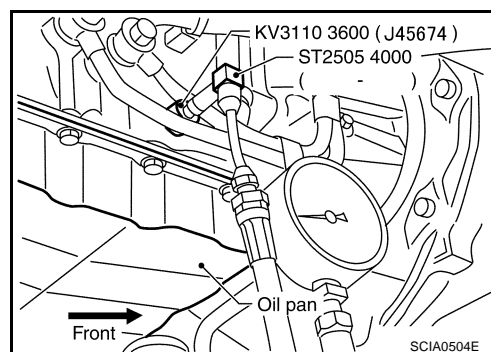

4. Securely engage the parking brake so that the tires do not turn.

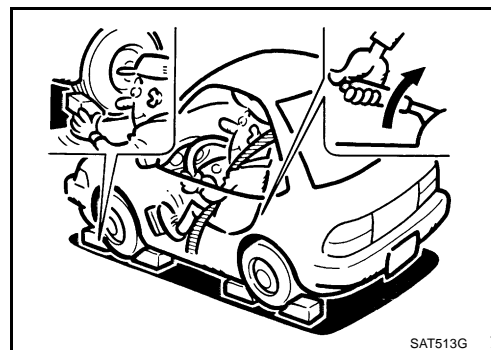

5. Start the engine, then measure the line pressure at both idle and the stall speed.

**CAUTION:**

- Keep the brake pedal pressed all the way down during measurement.
- When measuring the line pressure at the stall speed, refer to [AT-55. "STALL TEST"](#) .

6. After the measurements are complete, install the oil pressure detection plug and tighten to the regulation torque below.

**:7.3 N·m (0.74 kg·m, 65 in·lb)**

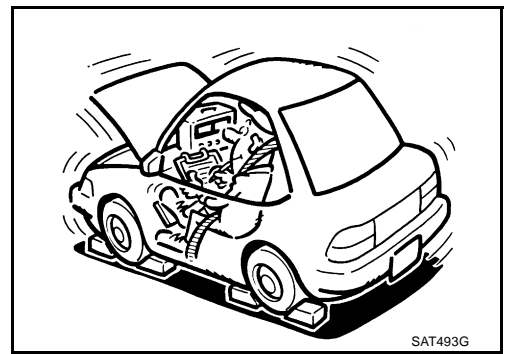

**CAUTION:**

Do not reuse the O-ring.

## Line pressure

Engine speed	Line pressure [kPa (kg/cm <sup>2</sup> , psi)]	
	R position	D, M positions
At idle speed	392 - 441 (4.0 - 4.5, 57 - 64)	373 - 422 (3.8 - 4.3, 54 - 61)
At stall speed	1,700 - 1,890 (17.3 - 19.3, 247 - 274)	1,310 - 1,500 (13.3 - 15.3, 190 - 218)

## Judgement of line pressure test

Judgement		Possible cause
Idle speed	Low for all positions (P, R, N, D, M)	Possible causes include malfunctions in the pressure supply system and low oil pump output. For example <ul style="list-style-type: none"> <li>● Oil pump wear</li> <li>● Pressure regulator valve or plug sticking or spring fatigue</li> <li>● Oil strainer ⇒ oil pump ⇒ pressure regulator valve passage oil leak</li> <li>● Engine idle speed too low</li> </ul>
	Only low for a specific position	Possible causes include an oil pressure leak in a passage or device related to the position after the pressure is distributed by the manual valve.
	High	Possible causes include a sensor malfunction or malfunction in the line pressure adjustment function. For example <ul style="list-style-type: none"> <li>● Accelerator pedal position signal malfunction</li> <li>● ATF temperature sensor malfunction</li> <li>● Line pressure solenoid malfunction (sticking in "OFF" state, filter clog, cut line)</li> <li>● Pressure regulator valve or plug sticking</li> </ul>
Stall speed	Oil pressure does not rise higher than the oil pressure for idle.	Possible causes include a sensor malfunction or malfunction in the pressure adjustment function. For example <ul style="list-style-type: none"> <li>● Accelerator pedal position signal malfunction</li> <li>● TCM breakdown</li> <li>● Line pressure solenoid malfunction (shorting, sticking in "ON" state)</li> <li>● Pressure regulator valve or plug sticking</li> <li>● Pilot valve sticking or pilot filter clogged</li> </ul>
	The pressure rises, but does not enter the standard position.	Possible causes include malfunctions in the pressure supply system and malfunction in the pressure adjustment function. For example <ul style="list-style-type: none"> <li>● Accelerator pedal position signal malfunction</li> <li>● Line pressure solenoid malfunction (sticking, filter clog)</li> <li>● Pressure regulator valve or plug sticking</li> <li>● Pilot valve sticking or pilot filter clogged</li> </ul>
	Only low for a specific position	Possible causes include an oil pressure leak in a passage or device related to the position after the pressure is distributed by the manual valve.

## ROAD TEST

### Description

- The road test inspects overall performance of the A/T and analyzes possible malfunction causes.
- The road test is carried out in the following three stages.
  1. Check before engine is started. Refer to [AT-59](#) .
  2. Check at idle. Refer to [AT-59](#) .
  3. Cruise test
    - Inspect all the items from Part 1 to Part 3. Refer to [AT-61](#) , [AT-63](#) , [AT-64](#) .
- Before beginning the road test, check the test procedure and inspection items.
- Test all inspection items until the symptom is uncovered. Diagnose NG items when all road tests are complete.

### Check Before Engine is Started

ACS000HO

#### 1. CHECK A/T CHECK INDICATOR LAMP

1. Park vehicle on level surface.
2. Move selector lever to “P” position.
3. Turn ignition switch to “OFF” position and wait at least 10 seconds.
4. Turn ignition switch to “ON” position. (Do not start engine.)

Does A/T CHECK indicator lamp light up for about 2 seconds?

YES >> GO TO 2.

NO >> Stop the road test and go to [AT-159, "A/T CHECK Indicator Lamp Does Not Come On"](#) .

#### 2. CHECK A/T CHECK INDICATOR LAMP

Does A/T CHECK indicator lamp flash for about 8 seconds?

YES >> For TCM fail-safe mode, carry out self-diagnostics and record all NG items on the diagnostics worksheet. Refer to [AT-76](#) , [AT-87](#) .

NO >> 1. Turn ignition switch to “OFF” position.

2. Carry out the self-diagnostics and record all NG items on the diagnostics worksheet. Refer to [AT-76](#) , [AT-87](#) .

3. Go to [AT-59, "Check at Idle"](#) .

### Check at Idle

ACS000HP

#### 1. CHECK STARTING THE ENGINE

1. Park vehicle on level surface.
2. Move selector lever to “P” or “N” position.
3. Turn ignition switch to “OFF” position.
4. Turn ignition switch to “START” position.

Does the engine start?

YES >> GO TO 2.

NO >> Stop the road test and go to [AT-160, "Engine Cannot Be Started In “P” or “N” Position"](#) .

#### 2. CHECK STARTING THE ENGINE

1. Turn ignition switch to “ON” position.
2. Move selector lever in “D” or “R” position.
3. Turn ignition switch to “START” position.

Does the engine start in either position?

YES >> Stop the road test and go to [AT-160, "Engine Cannot Be Started In “P” or “N” Position"](#) .

NO >> GO TO 3.

---

### 3. CHECK "P" POSITION FUNCTIONS

---

1. Move selector lever to "P" position.
2. Turn ignition switch to "OFF" position.
3. Release the parking brake.
4. Push the vehicle forward or backward.
5. Engage the parking brake.

When you push the vehicle with disengaging the parking brake, does it move?

- YES >> Enter a check mark at "In "P" position, Vehicle Moves When Pushed" on the diagnostics worksheet, then continue the road test.
- NO >> GO TO 4.

---

### 4. CHECK "N" POSITION FUNCTIONS

---

1. Start the engine.
2. Move selector lever to "N" position.
3. Release the parking brake.

Does vehicle move forward or backward?

- YES >> Enter a check mark at "In "N" position Vehicle Moves" on the diagnostics worksheet, then continue the road test.
- NO >> GO TO 5.

---

### 5. CHECK SHIFT SHOCK

---

1. Engage the brake.
2. Move selector lever to "D" position.

When the transmission is shifted from "N" to "D", is there an excessive shock?

- YES >> Enter a check mark at "Large Shock ("N" to "D" Position)" on the diagnostics worksheet, then continue the road test.
- NO >> GO TO 6.

---

### 6. CHECK "R" POSITION FUNCTIONS

---

1. Engage the brake.
2. Move selector lever to "R" position.
3. Release the brake for 4 to 5 seconds.

Does the vehicle creep backward?

- YES >> GO TO 7.
- NO >> Enter a check mark at "Vehicle Does Not Creep Backward in "R" Position" on the diagnostics worksheet, then continue the road test.

---

### 7. CHECK "D" POSITION FUNCTIONS

---

Inspect whether the vehicle moves forward when the transmission is put into the "D" position.

Does the vehicle move forward in the "D" positions?

- YES >> Go to [AT-61, "Cruise Test - Part 1"](#) , [AT-63, "Cruise Test - Part 2"](#) , and [AT-64, "Cruise Test - Part 3"](#) .
- NO >> Enter a check mark at "Vehicle Does not Creep Forward in "D" Position" on the diagnostics worksheet, then continue the road test.

## Cruise Test - Part 1

### Cruise test Part 1

#### 1. CHECK STARTING OUT FROM D1

1. Drive the vehicle for about 10 minutes to warm up the engine oil and A/T fluid.  
 Appropriate temperature for the A/T fluid: 50 - 80°C (122 - 176°F)
2. Park the vehicle on a level surface.
3. Move selector lever to "P" position.
4. Start the engine.
5. Move selector lever to "D" position.
6. Press the accelerator pedal about half way down to accelerate the vehicle.

**Ⓟ With CONSULT-II**

Read off the gear positions. Refer to [AT-80, "Data monitor mode \(A/T\)"](#) .

Starts from D1?

YES >> GO TO 2.

NO >> Enter a check mark at "Vehicle Cannot Be Started From D1" on the diagnostics worksheet, then continue the road test.

#### 2. CHECK SHIFT UP D1 → D2

Press down the accelerator pedal about half way and inspect if the vehicle shifts up (D1 → D2) at the appropriate speed.

- Refer to [AT-65](#) .

**Ⓟ With CONSULT-II**

Read the gear position, throttle degree of opening, and vehicle speed. Refer to [AT-80, "Data monitor mode \(A/T\)"](#) .

Does the A/T shift up D1 → D2 at the correct speed?

YES >> GO TO 3.

NO >> Enter a check mark at "A/T Does Not Shift D1 → D2" on the diagnostics worksheet, then continue the road test.

#### 3. CHECK SHIFT UP D2 → D3

Press down the accelerator pedal about half way and inspect if the vehicle shifts up (D2 → D3) at the appropriate speed.

- Refer to [AT-65](#) .

**Ⓟ With CONSULT-II**

Read the gear position, throttle degree of opening, and vehicle speed. Refer to [AT-80, "Data monitor mode \(A/T\)"](#) .

Does the A/T shift up D2 → D3 at the correct speed?

YES >> GO TO 4.

NO >> Enter a check mark at "A/T Does Not Shift D2 → D3" on the diagnostics worksheet, then continue the road test.

#### 4. CHECK SHIFT UP D3 → D4

Press down the accelerator pedal about half way and inspect if the vehicle shifts up (D3 → D4) at the appropriate speed.

- Refer to [AT-65](#) .

**Ⓜ With CONSULT-II**

Read the gear position, throttle degree of opening, and vehicle speed. Refer to Data [AT-80, "Data monitor mode \(A/T\)"](#) .

Does the A/T shift up D3 → D4 at the correct speed?

YES >> GO TO 5.

NO >> Enter a check mark at "A/T Does Not Shift D3 → D4" on the diagnostics worksheet, then continue the road test.

#### 5. CHECK SHIFT UP D4 → D5

Press down the accelerator pedal about half way and inspect if the vehicle shifts up (D4 → D5) at the appropriate speed.

- Refer to [AT-65](#) .

**Ⓜ With CONSULT-II**

Read the gear position, throttle degree of opening, and vehicle speed. Refer to [AT-80, "Data monitor mode \(A/T\)"](#) .

Does the A/T shift up D4 → D5 at the correct speed?

YES >> GO TO 6.

NO >> Enter a check mark at "A/T Does Not Shift D4 → D5" on the diagnostics worksheet, then continue the road test.

#### 6. CHECK LOCK-UP

When releasing accelerator pedal from D5, check lock-up from D5 to L/U.

- Refer to [AT-65](#) .

**Ⓜ With CONSULT-II**

Select "TCC SOL 0.00A" with the "MAIN SIGNAL" mode for "A/T".

Does it lock-up?

YES >> GO TO 7.

NO >> Enter a check mark at "A/T Does Not Perform Lock-up" on the diagnostics worksheet, then continue the road test.

#### 7. CHECK LOCK-UP HOLD

Check hold lock-up.

**Ⓜ With CONSULT-II**

Select "TCC SOL 0.00A" with the "MAIN SIGNAL" mode for "A/T".

Does it maintain lock-up status?

YES >> GO TO 8.

NO >> Enter a check mark at "A/T Does Not Hold Lock-up Condition" on the diagnostics worksheet, then continue the road test.

## 8. CHECK LOCK-UP RELEASE

Check lock-up cancellation by depressing brake pedal lightly to decelerate.

### With CONSULT-II

Select "TCC SOL 0.00A" with the "MAIN SIGNAL" mode for "A/T".

Does lock-up cancel?

YES >> GO TO 9.

NO >> Enter a check mark at "Lock-up is Not Released" on the diagnostics worksheet, then continue the road test.

## 9. CHECK SHIFT DOWN D5 → D4

Decelerate by pressing lightly on the brake pedal.

### With CONSULT-II

Read the gear position and engine speed. [AT-80, "Data monitor mode \(A/T\)"](#) .

When the A/T shift down D5 → D4, does the engine speed drop smoothly back to idle?

YES >> 1. Stop the vehicle.

2. Go to Cruise test - Part 2 (Refer to [AT-63](#) ).

NO >> Enter a check mark at "Engine Speed Does Not Return To Idle" on the diagnostics worksheet, then continue the road test. Go to Cruise test - Part 2 (Refer to [AT-63](#) ).

## Cruise Test - Part 2

ACS000HR

### Cruise test Part 2

#### 1. CHECK STARTING FROM D1

1. Move selector lever the "D" position.

2. Accelerate at half throttle.

### With CONSULT-II

Read the gear position. Refer to [AT-80, "Data monitor mode \(A/T\)"](#) .

Does it start from D1?

YES >> GO TO 2.

NO >> Enter a check mark at "Vehicle Cannot Be Started From D1" on the diagnostics worksheet, then continue the road test.

#### 2. CHECK SHIFT UP D1 → D2

Press the accelerator pedal down all the way and inspect whether or not the transmission shifts up (D1 → D2) at the correct speed.

- Refer to [AT-65](#) .

### With CONSULT-II

Read the gear position, throttle position and vehicle speed. Refer to [AT-80, "Data monitor mode \(A/T\)"](#) .

Does the A/T shift up D1 → D2 at the correct speed?

YES >> GO TO 3.

NO >> Enter a check mark at "Vehicle Does Not Shift D1 → D2" on the diagnostics worksheet, then continue the road test.

### 3. CHECK SHIFT UP D2 → D3

Press the accelerator pedal down all the way and inspect whether or not the transmission shifts up (D2 → D3) at the correct speed.

- Refer to [AT-65](#) .

#### Ⓜ With CONSULT-II

Read the gear position, throttle position and vehicle speed. Refer to [AT-80, "Data monitor mode \(A/T\)"](#) .

Does the A/T shift up D2 → D3 at the correct speed?

YES >> GO TO 4.

NO >> Enter a check mark at "Vehicle Does Not Shift D2 → D3" on the diagnostics worksheet, then continue the road test.

### 4. CHECK SHIFT UP D3 → D4 AND ENGINE BRAKE

When the transmission changes speed D3 → D4, return the accelerator pedal.

#### Ⓜ With CONSULT-II

Read the gear position. Refer to [AT-80, "Data monitor mode \(A/T\)"](#) .

Does the A/T shift up D3 → D4 and apply the engine brake?

YES >> 1. Stop the vehicle.

2. See [AT-64](#) .

NO >> Enter a check mark at "Vehicle Does Not Shift D3 → D4" on the diagnostics worksheet, then continue the road test. (Refer to [AT-64](#) ).

## Cruise Test - Part 3

ACS000HS

### Cruise test Part 3

#### 1. MANUAL MODE FUNCTION

Move to manual mode from D position.

Does it switch to manual mode?

YES >> GO TO 2.

NO >> Continue road test and add checkmark to "Cannot Be Changed To Manual Mode" on diagnostics worksheet.

#### 2. CHECK SHIFT DOWN

During manual mode driving, is downshift from M5 → M4 → M3 → M2 → M1 performed?

#### Ⓜ With CONSULT-II

Read the gear position. Refer to Data monitor.

Is downshifting correctly performed?

YES >> GO TO 2.

NO >> Enter a check mark at "Vehicle Does Not Shift" at the corresponding position (5th → 4th, 4th → 3rd, 3rd → 2nd, 2nd → 1st) on the diagnostics worksheet, then continue the road test.

#### 3. CHECK ENGINE BRAKE

Check engine brake.

Does engine braking effectively reduce speed in M1 position?

YES >> 1. Stop the vehicle.

2. Carry out the self-diagnostics. Refer to [AT-76, "SELF-DIAGNOSTIC PROCEDURE \(WITH CONSULT-II\)"](#) , [AT-87, "Diagnostic Procedure Without CONSULT-II"](#) .

NO >> Enter a check mark at "Vehicle does not decelerate by engine brake" on the diagnostics worksheet, then continue trouble diagnosis.



## Vehicle Speed When Shifting Gears

ACS000HT

Throttle position	Vehicle speed km/h (MPH)							
	D1 →D2	D2 →D3	D3 →D4	D4 →D5	D5 →D4	D4 →D3	D3 →D2	D2 →D1
Full throttle	58 - 62 (36 - 39)	90 - 98 (56 - 61)	140 - 150 (87 - 93)	201 - 211 (125 - 131)	197 - 207 (122 - 129)	122 - 132 (76 - 82)	74 - 82 (46 - 51)	34 - 38 (23 - 25)
Half throttle	46 - 50 (29 - 31)	71 - 79 (44 - 49)	107 - 117 (66 - 73)	135 - 145 (84 - 90)	88 - 98 (55 - 61)	63 - 73 (39 - 45)	29 - 37 (18 - 23)	11 - 15 (7 - 9)

- At half throttle, the accelerator opening is 4/8 of the full opening.

## Vehicle Speed When Performing and Releasing Complete Lock-up

ACS000HU

Throttle position	Vehicle speed km/h (MPH)	
	Lock-up "ON"	Lock-up "OFF"
Closed throttle	56 - 64 (35 - 40)	53 - 61 (33 - 38)
Half throttle	168 - 176 (104 - 109)	131 - 139 (81 - 86)

- At closed throttle, the accelerator opening is less than 1/8 condition.
- At half throttle, the accelerator opening is 4/8 of the full opening.

## Vehicle Speed When Performing and Releasing Slip Lock-up

ACS000HV

Throttle position	Gear position	Vehicle speed km/h (MPH)	
		Slip lock-up "ON"	Slip lock-up "OFF"
Closed throttle	4th	37 - 45 (23 - 28)	34 - 42 (21 - 26)
	5th	44 - 52 (27 - 32)	41 - 49 (25 - 30)

- At closed throttle, the accelerator opening is less than 1/8 condition.

## Symptom Chart

ACS000HW

The diagnostics item numbers show the sequence for inspection. Inspect in order from Item 1.

### CAUTION:

- If any malfunction occurs in the RE5R05A transmission, replace the transmission assembly.
- Condition for "on vehicle" only

Symptom	Diagnostic Item	Reference page
Shift point is high in D position.	1. Vehicle speed sensor A/T and vehicle speed sensor MTR	<a href="#">AT-96</a> , <a href="#">AT-118</a>
	2. Accelerator pedal position sensor	<a href="#">EC-546</a> , <a href="#">EC-552</a> , <a href="#">EC-564</a>
	3. Throttle position sensor	<a href="#">EC-481</a> , <a href="#">EC-483</a> , <a href="#">EC-558</a>
	4. ATF temperature sensor	<a href="#">AT-114</a>
Shift point is low in D position.	1. Vehicle speed sensor A/T and vehicle speed sensor MTR	<a href="#">AT-96</a> , <a href="#">AT-118</a>
	2. Accelerator pedal position sensor	<a href="#">EC-546</a> , <a href="#">EC-552</a> , <a href="#">EC-564</a>
	3. Throttle position sensor	<a href="#">EC-481</a> , <a href="#">EC-483</a> , <a href="#">EC-558</a>

Symptom	Diagnostic Item	Reference page
Large shock. ("N" → "D" position)	1. Engine idle speed	<a href="#">EC-30</a>
	2. Engine speed signal	<a href="#">AT-98</a>
	3. Accelerator pedal position sensor	<a href="#">EC-546, EC-552</a> , <a href="#">EC-564</a>
	4. Throttle position sensor	<a href="#">EC-481, EC-483</a> , <a href="#">EC-558</a>
	5. Control linkage adjustment	<a href="#">AT-182</a>
	6. ATF temperature sensor	<a href="#">AT-114</a>
	7. ATF pressure switch 1, front brake solenoid valve	<a href="#">AT-149, AT-129</a>
	8. CAN communication line	<a href="#">AT-89</a>
	9. Fluid level and state	<a href="#">AT-55</a>
Shock is too large when changing D1 → D2 or M1 → M2 .	1. Accelerator pedal position sensor	<a href="#">EC-546, EC-552</a> , <a href="#">EC-564</a>
	2. Throttle position sensor	<a href="#">EC-481, EC-483</a> , <a href="#">EC-558</a>
	3. Control linkage adjustment	<a href="#">AT-182</a>
	4. ATF pressure switch 5, direct clutch solenoid valve	<a href="#">AT-153, AT-133</a>
	5. CAN communication line	<a href="#">AT-89</a>
	6. Engine speed signal	<a href="#">AT-98</a>
	7. Turbine revolution sensor	<a href="#">AT-116</a>
	8. Vehicle speed sensor A/T and vehicle speed sensor MTR	<a href="#">AT-96, AT-118</a>
	9. Fluid level and state	<a href="#">AT-55</a>
Shock is too large when changing D2 → D3 or M2 → M3 .	1. Accelerator pedal position sensor	<a href="#">EC-546, EC-552</a> , <a href="#">EC-564</a>
	2. Throttle position sensor	<a href="#">EC-481, EC-483</a> , <a href="#">EC-558</a>
	3. Control linkage adjustment	<a href="#">AT-182</a>
	4. ATF pressure switch 6, high and low reverse clutch solenoid valve	<a href="#">AT-155, AT-137</a>
	5. CAN communication line	<a href="#">AT-89</a>
	6. Engine speed signal	<a href="#">AT-98</a>
	7. Turbine revolution sensor	<a href="#">AT-116</a>
	8. Vehicle speed sensor A/T and vehicle speed sensor MTR	<a href="#">AT-96, AT-118</a>
	9. Fluid level and state	<a href="#">AT-55</a>
Shock is too large when changing D3 → D4 or M3 → M4 .	1. Accelerator pedal position sensor	<a href="#">EC-546, EC-552</a> , <a href="#">EC-564</a>
	2. Throttle position sensor	<a href="#">EC-481, EC-483</a> , <a href="#">EC-558</a>
	3. Control linkage adjustment	<a href="#">AT-182</a>
	4. ATF pressure switch 3, input clutch solenoid valve	<a href="#">AT-151, AT-125</a>
	5. CAN communication line	<a href="#">AT-89</a>
	6. Engine speed signal	<a href="#">AT-98</a>
	7. Turbine revolution sensor	<a href="#">AT-116</a>
	8. Vehicle speed sensor A/T and vehicle speed sensor MTR	<a href="#">AT-96, AT-118</a>
	9. Fluid level and state	<a href="#">AT-55</a>

Symptom	Diagnostic Item	Reference page	
Shock is too large when changing D4 → D5 or M4 → M5 .	1. Accelerator pedal position sensor	<a href="#">EC-546</a> , <a href="#">EC-552</a> , <a href="#">EC-564</a>	A
	2. Throttle position sensor	<a href="#">EC-481</a> , <a href="#">EC-483</a> , <a href="#">EC-558</a>	B
	3. Control linkage adjustment	<a href="#">AT-182</a>	
	4. ATF pressure switch 1, front brake solenoid valve	<a href="#">AT-149</a> , <a href="#">AT-129</a>	AT
	5. CAN communication line	<a href="#">AT-89</a>	
	6. Engine speed signal	<a href="#">AT-98</a>	
	7. Turbine revolution sensor	<a href="#">AT-116</a>	D
	8. Vehicle speed sensor A/T and vehicle speed sensor MTR	<a href="#">AT-96</a> , <a href="#">AT-118</a>	
	9. Fluid level and state	<a href="#">AT-55</a>	E
Shock is too large for downshift when accelerator pedal is pressed.	1. Accelerator pedal position sensor	<a href="#">EC-546</a> , <a href="#">EC-552</a> , <a href="#">EC-564</a>	
	2. Throttle position sensor	<a href="#">EC-481</a> , <a href="#">EC-483</a> , <a href="#">EC-558</a>	F
	3. Control linkage adjustment	<a href="#">AT-182</a>	
	4. CAN communication line	<a href="#">AT-89</a>	G
	5. Engine speed signal	<a href="#">AT-98</a>	
	6. Turbine revolution sensor	<a href="#">AT-116</a>	H
	7. Vehicle speed sensor A/T and vehicle speed sensor MTR	<a href="#">AT-96</a> , <a href="#">AT-118</a>	
	8. Fluid level and state	<a href="#">AT-55</a>	
Shock is too large for upshift when accelerator pedal is released.	1. Accelerator pedal position sensor	<a href="#">EC-546</a> , <a href="#">EC-552</a> , <a href="#">EC-564</a>	I
	2. Throttle position sensor	<a href="#">EC-481</a> , <a href="#">EC-483</a> , <a href="#">EC-558</a>	
	3. Control linkage adjustment	<a href="#">AT-182</a>	J
	4. Engine speed signal	<a href="#">AT-98</a>	
	5. CAN communication line	<a href="#">AT-89</a>	K
	6. Turbine revolution sensor	<a href="#">AT-116</a>	
	7. Vehicle speed sensor A/T and vehicle speed sensor MTR	<a href="#">AT-96</a> , <a href="#">AT-118</a>	L
	8. Fluid level and state	<a href="#">AT-55</a>	
Shock is too large for lock-up.	1. Accelerator pedal position sensor	<a href="#">EC-546</a> , <a href="#">EC-552</a> , <a href="#">EC-564</a>	M
	2. Throttle position sensor	<a href="#">EC-481</a> , <a href="#">EC-483</a> , <a href="#">EC-558</a>	
	3. Control linkage adjustment	<a href="#">AT-182</a>	
	4. Engine speed signal	<a href="#">AT-98</a>	
	5. CAN communication line	<a href="#">AT-89</a>	
	6. Turbine revolution sensor	<a href="#">AT-116</a>	
	7. Vehicle speed sensor A/T and vehicle speed sensor MTR	<a href="#">AT-96</a> , <a href="#">AT-118</a>	
	8. Torque converter clutch solenoid valve	<a href="#">AT-100</a>	
	9. Fluid level and state	<a href="#">AT-55</a>	

Symptom	Diagnostic Item	Reference page
Shock is too large during engine brake.	1. Accelerator pedal position sensor	<a href="#">EC-546, EC-552</a> , <a href="#">EC-564</a>
	2. Throttle position sensor	<a href="#">EC-481, EC-483</a> , <a href="#">EC-558</a>
	3. Control linkage adjustment	<a href="#">AT-182</a>
	4. CAN communication line	<a href="#">AT-89</a>
	5. Fluid level and state	<a href="#">AT-55</a>
Judder occurs during lock-up.	1. Fluid level and state	<a href="#">AT-55</a>
	2. Engine speed signal	<a href="#">AT-98</a>
	3. Turbine revolution sensor	<a href="#">AT-116</a>
	4. Vehicle speed sensor A/T and vehicle speed sensor MTR	<a href="#">AT-96, AT-118</a>
	5. Accelerator pedal position sensor	<a href="#">EC-546, EC-552</a> , <a href="#">EC-564</a>
	6. Throttle position sensor	<a href="#">EC-481, EC-483</a> , <a href="#">EC-558</a>
	7. Torque converter clutch solenoid valve	<a href="#">AT-100</a>
Strange noise in "R", "N" or " D" position.	1. Fluid level and state	<a href="#">AT-55</a>
	2. Engine speed signal	<a href="#">AT-98</a>
When D or M position, remains in 1st gear.	1. Fluid level and state	<a href="#">AT-55</a>
	2. Vehicle speed sensor A/T and vehicle speed sensor MTR	<a href="#">AT-96, AT-118</a>
	3. Direct clutch solenoid valve	<a href="#">AT-133</a>
	4. Line pressure test	<a href="#">AT-57</a>
When D or M position, remains in 2nd gear.	1. Fluid level and state	<a href="#">AT-55</a>
	2. Vehicle speed sensor A/T and vehicle speed sensor MTR	<a href="#">AT-96, AT-118</a>
	3. Low coast brake solenoid valve	<a href="#">AT-141</a>
	4. Line pressure test	<a href="#">AT-57</a>
When D or M position, remains in 3rd gear.	1. Fluid level and state	<a href="#">AT-55</a>
	2. Vehicle speed sensor A/T and vehicle speed sensor MTR	<a href="#">AT-96, AT-118</a>
	3. Line pressure test	<a href="#">AT-57</a>
When D or M position, remains in 4th gear.	1. Fluid level and state	<a href="#">AT-55</a>
	2. Vehicle speed sensor A/T and vehicle speed sensor MTR	<a href="#">AT-96, AT-118</a>
	3. ATF pressure switch 3, input clutch solenoid valve	<a href="#">AT-151, AT-125</a>
	4. ATF pressure switch 5, direct clutch solenoid valve	<a href="#">AT-153, AT-133</a>
	5. ATF pressure switch 6, high and low reverse clutch solenoid valve	<a href="#">AT-155, AT-137</a>
	6. Low coast brake solenoid valve	<a href="#">AT-141</a>
	7. Front brake solenoid valve	<a href="#">AT-129</a>
	8. Line pressure test	<a href="#">AT-57</a>
When D or M position, remains in 5th gear.	1. Fluid level and state	<a href="#">AT-55</a>
	2. Vehicle speed sensor A/T and vehicle speed sensor MTR	<a href="#">AT-96, AT-118</a>
	3. ATF pressure switch 1, front brake solenoid valve	<a href="#">AT-149, AT-129</a>
	4. Line pressure test	<a href="#">AT-57</a>
Gear does not change from D1 → D2 or from M1 → M2 .	1. Fluid level and state	<a href="#">AT-55</a>
	2. Vehicle speed sensor A/T and vehicle speed sensor MTR	<a href="#">AT-96, AT-118</a>
	3. ATF pressure switch 5, direct clutch solenoid valve	<a href="#">AT-153, AT-133</a>
	4. Line pressure test	<a href="#">AT-57</a>

Symptom	Diagnostic Item	Reference page
Gear does not change from D2 → D3 or from M2 → M3 .	1. Fluid level and state	<a href="#">AT-55</a>
	2. Vehicle speed sensor A/T and vehicle speed sensor MTR	<a href="#">AT-96, AT-118</a>
	3. ATF pressure switch 6, high and low reverse clutch solenoid valve	<a href="#">AT-155, AT-137</a>
	4. Line pressure test	<a href="#">AT-57</a>
Gear does not change from D3 → D4 or from M3 → M4 .	1. Fluid level and state	<a href="#">AT-55</a>
	2. Vehicle speed sensor A/T and vehicle speed sensor MTR	<a href="#">AT-96, AT-118</a>
	3. ATF pressure switch 3, input clutch solenoid valve	<a href="#">AT-151, AT-125</a>
	4. ATF pressure switch 1, front brake solenoid valve	<a href="#">AT-149, AT-129</a>
	5. Line pressure test	<a href="#">AT-57</a>
Gear does not change from D4 → D5 or from M4 → M5 .	1. Fluid level and state	<a href="#">AT-55</a>
	2. Vehicle speed sensor A/T and vehicle speed sensor MTR	<a href="#">AT-96, AT-118</a>
	3. ATF pressure switch 1, front brake solenoid valve	<a href="#">AT-149, AT-129</a>
	4. ATF pressure switch 5, direct clutch solenoid valve	<a href="#">AT-153, AT-133</a>
	5. Turbine revolution sensor	<a href="#">AT-116</a>
	6. Line pressure test	<a href="#">AT-57</a>
In D range, does not downshift to 4th gear.	1. Fluid level and state	<a href="#">AT-55</a>
	2. Vehicle speed sensor A/T and vehicle speed sensor MTR	<a href="#">AT-96, AT-118</a>
	3. ATF pressure switch 1, front brake solenoid valve	<a href="#">AT-149, AT-129</a>
	4. ATF pressure switch 5, direct clutch solenoid valve	<a href="#">AT-153, AT-133</a>
	5. Line pressure test	<a href="#">AT-57</a>
In D range, does not downshift to 3rd gear.	1. Fluid level and state	<a href="#">AT-55</a>
	2. Vehicle speed sensor A/T and vehicle speed sensor MTR	<a href="#">AT-96, AT-118</a>
	3. ATF pressure switch 3, input clutch solenoid valve	<a href="#">AT-151, AT-125</a>
	4. ATF pressure switch 1, front brake solenoid valve	<a href="#">AT-149, AT-129</a>
	5. Line pressure test	<a href="#">AT-57</a>
In D range, does not downshift to 2nd gear.	1. Fluid level and state	<a href="#">AT-55</a>
	2. Vehicle speed sensor A/T and vehicle speed sensor MTR	<a href="#">AT-96, AT-118</a>
	3. ATF pressure switch 6, high and low reverse clutch solenoid valve	<a href="#">AT-155, AT-137</a>
	4. Line pressure test	<a href="#">AT-57</a>
In D range, does not downshift to 1st gear.	1. Fluid level and state	<a href="#">AT-55</a>
	2. Vehicle speed sensor A/T and vehicle speed sensor MTR	<a href="#">AT-96, AT-118</a>
	3. ATF pressure switch 5, direct clutch solenoid valve	<a href="#">AT-153, AT-133</a>
	4. Line pressure test	<a href="#">AT-57</a>
Does not lock up.	1. Fluid level and state	<a href="#">AT-55</a>
	2. Line pressure test	<a href="#">AT-57</a>
	3. Engine speed signal	<a href="#">AT-98</a>
	4. Turbine revolution sensor	<a href="#">AT-116</a>
	5. Torque converter clutch solenoid valve	<a href="#">AT-100</a>
	6. CAN communication line	<a href="#">AT-89</a>
Does not change M5 → M4.	1. PNP switch	<a href="#">AT-94</a>
	2. Fluid level and state	<a href="#">AT-55</a>
	3. Control linkage adjustment	<a href="#">AT-182</a>
	4. Manual mode switch	<a href="#">AT-145</a>
	5. ATF pressure switch 1	<a href="#">AT-149</a>

Symptom	Diagnostic Item	Reference page
Does not change M4 → M3.	1. PNP switch	<a href="#">AT-94</a>
	2. Fluid level and state	<a href="#">AT-55</a>
	3. Control linkage adjustment	<a href="#">AT-182</a>
	4. Manual mode switch	<a href="#">AT-145</a>
	5. ATF pressure switch 1, ATF pressure switch 3	<a href="#">AT-149, AT-151</a>
Does not change M3 → M2.	1. PNP switch	<a href="#">AT-94</a>
	2. Fluid level and state	<a href="#">AT-55</a>
	3. Control linkage adjustment	<a href="#">AT-182</a>
	4. Manual mode switch	<a href="#">AT-145</a>
	5. ATF pressure switch 6	<a href="#">AT-155</a>
Does not change M2 → M1.	1. PNP switch	<a href="#">AT-94</a>
	2. Fluid level and state	<a href="#">AT-55</a>
	3. Control linkage adjustment	<a href="#">AT-182</a>
	4. Manual mode switch	<a href="#">AT-145</a>
	5. ATF pressure switch 5	<a href="#">AT-153</a>
No shock at all or the clutch slips when vehicle changes speed D1 → D2 or M1 → M2 .	1. Fluid level and state	<a href="#">AT-55</a>
	2. Vehicle speed sensor A/T and vehicle speed sensor MTR	<a href="#">AT-96, AT-118</a>
	3. ATF pressure switch 5, direct clutch solenoid valve	<a href="#">AT-153, AT-133</a>
	4. Line pressure test	<a href="#">AT-57</a>
No shock at all or the clutch slips when vehicle changes speed D2 → D3 or M2 → M3 .	1. Fluid level and state	<a href="#">AT-55</a>
	2. Vehicle speed sensor A/T and vehicle speed sensor MTR	<a href="#">AT-96, AT-118</a>
	3. ATF pressure switch 6, high and low reverse clutch solenoid valve	<a href="#">AT-155, AT-137</a>
	4. Line pressure test	<a href="#">AT-57</a>
No shock at all or the clutch slips when vehicle changes speed D3 → D4 or M3 → M4 .	1. Fluid level and state	<a href="#">AT-55</a>
	2. Vehicle speed sensor A/T and vehicle speed sensor MTR	<a href="#">AT-96, AT-118</a>
	3. ATF pressure switch 3, input clutch solenoid valve	<a href="#">AT-151, AT-125</a>
	4. ATF pressure switch 1, front brake solenoid valve	<a href="#">AT-149, AT-129</a>
	5. Line pressure test	<a href="#">AT-57</a>
No shock at all or the clutch slips when vehicle changes speed D4 → D5 or M4 → M5 .	1. Fluid level and state	<a href="#">AT-55</a>
	2. Vehicle speed sensor A/T and vehicle speed sensor MTR	<a href="#">AT-96, AT-118</a>
	3. ATF pressure switch 1, front brake solenoid valve	<a href="#">AT-149, AT-129</a>
	4. ATF pressure switch 5, direct clutch solenoid valve	<a href="#">AT-153, AT-133</a>
	5. Line pressure test	<a href="#">AT-57</a>
When you press the accelerator pedal and shift speed D5 → D4 or M5 → M4 the engine idles or the transmission slips.	1. Fluid level and state	<a href="#">AT-55</a>
	2. Vehicle speed sensor A/T and vehicle speed sensor MTR	<a href="#">AT-96, AT-118</a>
	3. ATF pressure switch 1, front brake solenoid valve	<a href="#">AT-149, AT-129</a>
	4. ATF pressure switch 5, direct clutch solenoid valve	<a href="#">AT-153, AT-133</a>
	5. Line pressure test	<a href="#">AT-57</a>
When you press the accelerator pedal and shift speed D4 → D3 or M4 → M3 the engine idles or the transmission slips.	1. Fluid level and state	<a href="#">AT-55</a>
	2. Vehicle speed sensor A/T and vehicle speed sensor MTR	<a href="#">AT-96, AT-118</a>
	3. ATF pressure switch 3, input clutch solenoid valve	<a href="#">AT-151, AT-125</a>
	4. ATF pressure switch 1, front brake solenoid valve	<a href="#">AT-149, AT-129</a>
	5. Line pressure test	<a href="#">AT-57</a>

Symptom	Diagnostic Item	Reference page
When you press the accelerator pedal and shift speed D3 → D2 or M3 → M2 the engine idles or the transmission slips.	1. Fluid level and state	<a href="#">AT-55</a>
	2. Vehicle speed sensor A/T and vehicle speed sensor MTR	<a href="#">AT-96</a> , <a href="#">AT-118</a>
	3. ATF pressure switch 6, high and low reverse clutch solenoid valve	<a href="#">AT-155</a> , <a href="#">AT-137</a>
	4. ATF pressure switch 5, direct clutch solenoid valve	<a href="#">AT-153</a> , <a href="#">AT-133</a>
	5. Line pressure test	<a href="#">AT-57</a>
When you press the accelerator pedal and shift speed D2 → D1 or M2 → M1 the engine idles or the transmission slips.	1. Fluid level and state	<a href="#">AT-55</a>
	2. Vehicle speed sensor A/T and vehicle speed sensor MTR	<a href="#">AT-96</a> , <a href="#">AT-118</a>
	3. ATF pressure switch 5, direct clutch solenoid valve	<a href="#">AT-153</a> , <a href="#">AT-133</a>
	4. Line pressure test	<a href="#">AT-57</a>
Engine brake does not work M5 → M4.	1. PNP switch	<a href="#">AT-94</a>
	2. Fluid level and state	<a href="#">AT-55</a>
	3. Control linkage adjustment	<a href="#">AT-182</a>
	4. Manual mode switch	<a href="#">AT-145</a>
	5. ATF pressure switch 1	<a href="#">AT-149</a>
Engine brake does not work M4 → M3.	1. PNP switch	<a href="#">AT-94</a>
	2. Fluid level and state	<a href="#">AT-55</a>
	3. Control linkage adjustment	<a href="#">AT-182</a>
	4. Manual mode switch	<a href="#">AT-145</a>
	5. ATF pressure switch 1, ATF pressure switch 3	<a href="#">AT-149</a> , <a href="#">AT-151</a>
Engine brake does not work M3 → M2.	1. PNP switch	<a href="#">AT-94</a>
	2. Fluid level and state	<a href="#">AT-55</a>
	3. Control linkage adjustment	<a href="#">AT-182</a>
	4. Manual mode switch	<a href="#">AT-145</a>
	5. ATF pressure switch 6	<a href="#">AT-155</a>
Engine brake does not work M2 → M1.	1. PNP switch	<a href="#">AT-94</a>
	2. Fluid level and state	<a href="#">AT-55</a>
	3. Control linkage adjustment	<a href="#">AT-182</a>
	4. Manual mode switch	<a href="#">AT-145</a>
	5. ATF pressure switch 5	<a href="#">AT-153</a>
With selector lever in D position, acceleration is extremely poor.	1. Fluid level and state	<a href="#">AT-55</a>
	2. Line pressure test	<a href="#">AT-57</a>
	3. Accelerator pedal position sensor	<a href="#">EC-546</a> , <a href="#">EC-552</a> , <a href="#">EC-564</a>
	4. Throttle position sensor	<a href="#">EC-481</a> , <a href="#">EC-483</a> , <a href="#">EC-558</a>
	5. CAN communication line	<a href="#">AT-89</a>
	6. PNP switch	<a href="#">AT-94</a>
	7. Control linkage adjustment	<a href="#">AT-182</a>

A  
B  
AT  
D  
E  
F  
G  
H  
I  
J  
K  
L  
M

Symptom	Diagnostic Item	Reference page
With selector lever in R position, acceleration is extremely poor.	1. Fluid level and state	<a href="#">AT-55</a>
	2. Line pressure test	<a href="#">AT-57</a>
	3. Accelerator pedal position sensor	<a href="#">EC-546, EC-552</a> , <a href="#">EC-564</a>
	4. Throttle position sensor	<a href="#">EC-481, EC-483</a> , <a href="#">EC-558</a>
	5. ATF pressure switch 6, high and low reverse clutch solenoid valve	<a href="#">AT-155, AT-137</a>
	6. CAN communication line	<a href="#">AT-89</a>
	7. PNP switch	<a href="#">AT-94</a>
	8. Control linkage adjustment	<a href="#">AT-182</a>
While starting off by accelerating in 1st, engine races or slippage occurs.	1. Fluid level and state	<a href="#">AT-55</a>
	2. Line pressure test	<a href="#">AT-57</a>
	3. Accelerator pedal position sensor	<a href="#">EC-546, EC-552</a> , <a href="#">EC-564</a>
	4. Throttle position sensor	<a href="#">EC-481, EC-483</a> , <a href="#">EC-558</a>
	5. CAN communication line	<a href="#">AT-89</a>
While accelerating in 2nd, engine races or slippage occurs.	1. Fluid level and state	<a href="#">AT-55</a>
	2. Line pressure test	<a href="#">AT-57</a>
	3. Accelerator pedal position sensor	<a href="#">EC-546, EC-552</a> , <a href="#">EC-564</a>
	4. Throttle position sensor	<a href="#">EC-481, EC-483</a> , <a href="#">EC-558</a>
	5. CAN communication line	<a href="#">AT-89</a>
	6. ATF pressure switch 5, direct clutch solenoid valve	<a href="#">AT-153, AT-133</a>
While accelerating in 3rd, engine races or slippage occurs.	1. Fluid level and state	<a href="#">AT-55</a>
	2. Line pressure test	<a href="#">AT-57</a>
	3. Accelerator pedal position sensor	<a href="#">EC-546, EC-552</a> , <a href="#">EC-564</a>
	4. Throttle position sensor	<a href="#">EC-481, EC-483</a> , <a href="#">EC-558</a>
	5. CAN communication line	<a href="#">AT-89</a>
	6. ATF pressure switch 6, high and low reverse clutch solenoid valve	<a href="#">AT-155, AT-137</a>
While accelerating in 4th, engine races or slippage occurs.	1. Fluid level and state	<a href="#">AT-55</a>
	2. Line pressure test	<a href="#">AT-57</a>
	3. Accelerator pedal position sensor	<a href="#">EC-546, EC-552</a> , <a href="#">EC-564</a>
	4. Throttle position sensor	<a href="#">EC-481, EC-483</a> , <a href="#">EC-558</a>
	5. CAN communication line	<a href="#">AT-89</a>
	6. ATF pressure switch 3, input clutch solenoid valve	<a href="#">AT-151, AT-125</a>



Symptom	Diagnostic Item	Reference page
While accelerating in 5th, engine races or slippage occurs.	1. Fluid level and state	<a href="#">AT-55</a>
	2. Line pressure test	<a href="#">AT-57</a>
	3. Accelerator pedal position sensor	<a href="#">EC-546, EC-552</a> , <a href="#">EC-564</a>
	4. Throttle position sensor	<a href="#">EC-481, EC-483</a> , <a href="#">EC-558</a>
	5. CAN communication line	<a href="#">AT-89</a>
	6. ATF pressure switch 1, front brake solenoid valve	<a href="#">AT-149, AT-129</a>
Slips at lock-up.	1. Fluid level and state	<a href="#">AT-55</a>
	2. Line pressure test	<a href="#">AT-57</a>
	3. Engine speed signal	<a href="#">AT-98</a>
	4. Turbine revolution sensor	<a href="#">AT-116</a>
	5. Torque converter clutch solenoid valve	<a href="#">AT-100</a>
	6. CAN communication line	<a href="#">AT-89</a>
Maximum speed low.	1. Fluid level and state	<a href="#">AT-55</a>
	2. Line pressure test	<a href="#">AT-57</a>
	3. Accelerator pedal position sensor	<a href="#">EC-546, EC-552</a> , <a href="#">EC-564</a>
	4. Throttle position sensor	<a href="#">EC-481, EC-483</a> , <a href="#">EC-558</a>
	5. CAN communication line	<a href="#">AT-89</a>
	6. Direct clutch solenoid valve	<a href="#">AT-133</a>
No creep at all.	1. Fluid level and state	<a href="#">AT-55</a>
	2. Engine speed signal	<a href="#">AT-98</a>
	3. CAN communication line	<a href="#">AT-89</a>
	4. ATF pressure switch 5, direct clutch solenoid valve	<a href="#">AT-153, AT-133</a>
Extremely large creep.	1. Engine idle speed	<a href="#">EC-30</a>
	2. CAN communication line	<a href="#">AT-89</a>
	3. ATF pressure switch 5	<a href="#">AT-153</a>
With selector lever in P position, vehicle does not enter parking condition or, with selector lever in another position, parking condition is not cancelled.	1. PNP switch	<a href="#">AT-94</a>
	2. Control linkage adjustment	<a href="#">AT-182</a>
Vehicle runs with transmission in "P" position.	1. PNP switch	<a href="#">AT-94</a>
	2. Fluid level and state	<a href="#">AT-55</a>
	3. Control linkage adjustment	<a href="#">AT-182</a>
	4. Line pressure test	<a href="#">AT-57</a>
Vehicle runs with transmission in "N" position.	1. PNP switch	<a href="#">AT-94</a>
	2. Fluid level and state	<a href="#">AT-55</a>
	3. Control linkage adjustment	<a href="#">AT-182</a>
	4. Line pressure test	<a href="#">AT-57</a>
Vehicle cannot run in all positions.	1. Fluid level and state	<a href="#">AT-55</a>
	2. Line pressure test	<a href="#">AT-57</a>
	3. PNP switch	<a href="#">AT-94</a>
	4. Control linkage adjustment	<a href="#">AT-182</a>

Symptom	Diagnostic Item	Reference page
With selector lever in D position, driving is not possible.	1. Fluid level and state	<a href="#">AT-55</a>
	2. Line pressure test	<a href="#">AT-57</a>
	3. PNP switch	<a href="#">AT-94</a>
	4. Control linkage adjustment	<a href="#">AT-182</a>
With selector lever in R position, driving is not possible.	1. Fluid level and state	<a href="#">AT-55</a>
	2. Line pressure test	<a href="#">AT-57</a>
	3. PNP switch	<a href="#">AT-94</a>
	4. Control linkage adjustment	<a href="#">AT-182</a>
Engine does not start in "N", "P" position.	1. Ignition switch and starter	<a href="#">PG-4, SC-10</a>
	2. Control linkage adjustment	<a href="#">AT-182</a>
	3. PNP switch	<a href="#">AT-94</a>
Engine starts in positions other than "N" or "P".	1. Ignition switch and starter	<a href="#">PG-4, SC-10</a>
	2. Control linkage adjustment	<a href="#">AT-182</a>
	3. PNP switch	<a href="#">AT-94</a>
Engine stall.	1. Fluid level and state	<a href="#">AT-55</a>
	2. Engine speed signal	<a href="#">AT-98</a>
	3. Turbine revolution sensor	<a href="#">AT-116</a>
	4. Torque converter clutch solenoid valve	<a href="#">AT-100</a>
Engine stalls when select lever shifted "N" → "D", "R".	1. Fluid level and state	<a href="#">AT-55</a>
	2. Engine speed signal	<a href="#">AT-98</a>
	3. Turbine revolution sensor	<a href="#">AT-116</a>
	4. Torque converter clutch solenoid valve	<a href="#">AT-100</a>

## TCM Input/Output Signal Reference Values A/T ASSEMBLY TERMINAL CONNECTOR LAYOUT



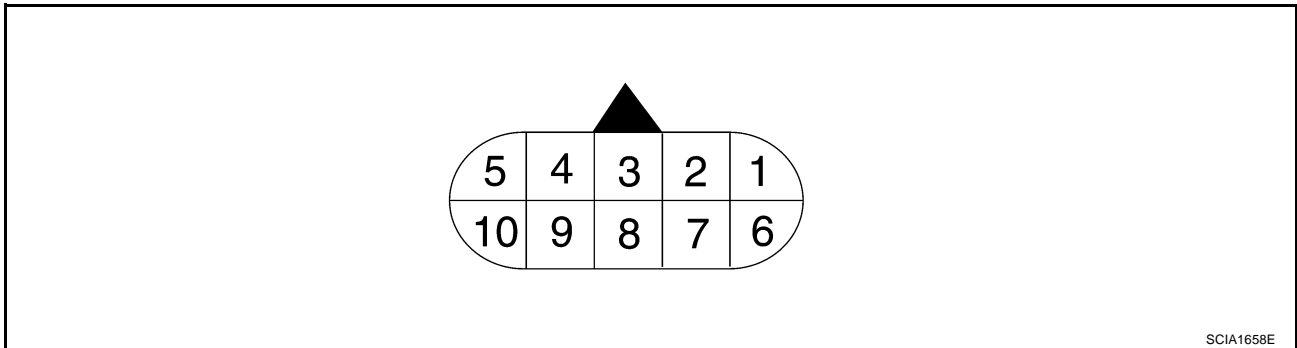

ACS000HX



### TCM INSPECTION TABLE

Data are reference value and are measured between each terminal and ground.

Terminal No.	Wire color	Item	Condition	Data (Approx.)
1	R/W	Power supply (Memory back-up)	Always	Battery voltage
2	R/W	Power supply (Memory back-up)	Always	Battery voltage
3	L	CAN-H	—	—
4	PU/W	K-line (CONSULT-II signal)	The terminal is connected to the data link connector for CONSULT-II.	—
5	B	Ground	—	—

Terminal No.	Wire color	Item	Condition	Data (Approx.)	
6	Y/R	Power supply		-	Battery voltage
				-	0V
7	P	Back-up lamp relay		Selector lever in "R" position.	0V
				Selector lever in other positions.	Battery voltage
8	P	CAN-L	-	-	
9	GY/R	Starter relay		Selector lever in "N", "P" positions.	Battery voltage
				Selector lever in other positions.	0V
10	B	Ground	-	-	

## CONSULT-II

ACS000HY

After performing [AT-87, "Diagnostic Procedure Without CONSULT-II"](#) , place check marks for results on the [AT-43, "DIAGNOSTIC WORKSHEET"](#) . Reference pages are provided following the items.

### NOTICE:

- The CONSULT-II electrically displays shift timing and lock-up timing (that is, operation timing of each solenoid).  
Check for time difference between actual shift timing and the CONSULT-II display. If the difference is noticeable, mechanical parts (except solenoids, sensors, etc.) may be malfunctioning. Check mechanical parts using applicable diagnostic procedures.
- Shift schedule (which implies gear position) displayed on CONSULT-II and that indicated in Service Manual may differ slightly. This occurs because of the following reasons:
  - Actual shift schedule has more or less tolerance or allowance,
  - Shift schedule indicated in Service Manual refers to the point where shifts start, and
  - Gear position displayed on CONSULT-II indicates the point where shifts are completed.
- Display of solenoid valves on CONSULT-II changes at the start of shifting, while gear position is displayed upon completion of shifting (which is computed by TCM).
- Additional CONSULT-II information can be found in the Operation Manual supplied with the CONSULT-II unit.

## CONSULT-II REFERENCE VALUE

Item name	Condition	Display value
ATF TEMP SE 1	0°C (32° F) - 20°C (68°F) - 80°C (176°F)	3.2 - 2.5 - 0.8 V
ATF TEMP SE 2		3.2 - 2.4 - 0.65 V
TCC SOLENOID	When perform slip lock-up	0.2 - 0.4 A
	When perform lock-up	0.4 - 0.6 A
SLCTLVR POSI	Selector lever in "N", "P" position.	N/P
	Selector lever in "R" position.	R
	Selector lever in "D" position.	D
VHCL/S SE-A/T	During driving	Approximately matches the speedometer reading.
ENGINE SPEED	Engine running	Closely matches the tachometer reading.
LINE PRES SOL	During driving	0.2 - 0.6
TURBINE REV	During driving (lock-up ON)	Approximately matches the engine speed.
VHCL/S SE-MTR	During driving	Approximately matches the speedometer reading.

Item name	Condition	Display value
ON OFF SOL	Low coast brake operates. Refer to <a href="#">AT-17</a>	ON
ATF PRES SW 1	Front brake operates. Refer to <a href="#">AT-17</a>	ON
	Other conditions	OFF
ATF PRES SW 2	Low coast brake operates. Refer to <a href="#">AT-17</a>	ON
	Other conditions	OFF
ATF PRES SW 3	Input clutch operates. Refer to <a href="#">AT-17</a>	ON
	Other conditions	OFF
ATF PRES SW 5	Direct clutch operates. Refer to <a href="#">AT-17</a>	ON
	Other conditions	OFF
ATF PRES SW 6	High and low reverse clutch operates. Refer to <a href="#">AT-17</a>	ON
	Other conditions	OFF
I/C SOLENOID	Input clutch operates. Refer to <a href="#">AT-17</a>	0.6 - 0.8
	Other conditions	0 - 0.05
FR/B SOLENOID	Front brake operates. Refer to <a href="#">AT-17</a>	0.6 - 0.8
	Other conditions	0 - 0.05
D/C SOLENOID	Direct clutch operates. Refer to <a href="#">AT-17</a>	0.6 - 0.8
	Other conditions	0 - 0.05
HLR/C SOL	High and low reverse clutch operates. Refer to <a href="#">AT-17</a>	0.6 - 0.8
	Other conditions	0 - 0.05
ON OFF SOL	Low coast brake operates. Refer to <a href="#">AT-17</a>	ON
	Other conditions	OFF
ATF PRES SW 2	Low coast brake operates. Refer to <a href="#">AT-17</a>	ON
	Other conditions	OFF

## Ⓜ SELF-DIAGNOSTIC PROCEDURE (WITH CONSULT-II)

### CONSULT-II setting procedure

#### CAUTION:

If CONSULT-II is used with no connection of CONSULT-II CONVERTER, malfunctions might be detected in self-diagnosis depending on control unit which carry out CAN communication.

- For details, refer to the separate "CONSULT-II Operations Manual".
1. Turn ignition switch "OFF".
  2. Connect CONSULT-II and CONSULT-II CONVERTER to data link connector, which is located in instrument lower panel on driver side.

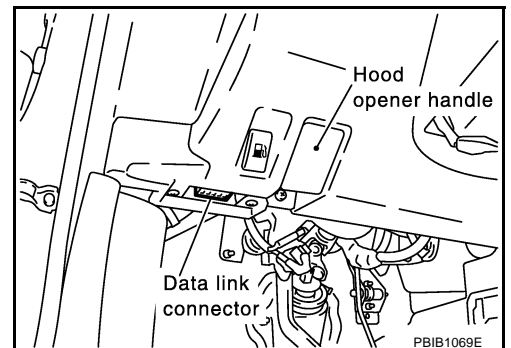

3. Turn ignition switch "ON". (Do not start engine.)

4. Touch "START (NISSAN BASED VHCL)".

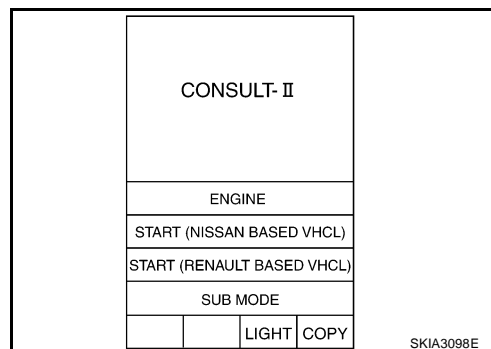

5. Touch "A/T".

If "A/T" is not indicated, go to [GI-39, "CONSULT-II Data Link Connector \(DLC\) Circuit"](#).

6. Perform each diagnostic test mode according to each service procedure.

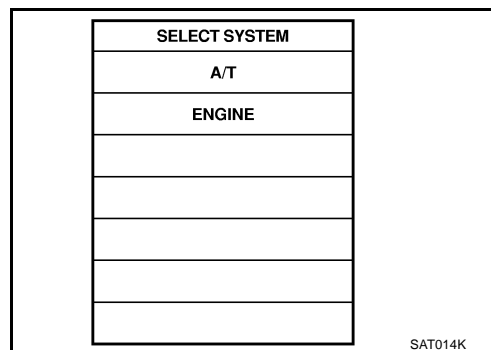

### Self-diagnostic result test mode

X: Applicable, —: Not applicable

Items (CONSULT-II screen terms)	Malfunction is detected when...	TCM self-diagnosis		OBD-II (DTC)
		A/T CHECK indicator lamp	"A/T" with CONSULT-II	MIL indicator lamp*1, "ENGINE" with CONSULT-II or GST
CAN COMM CIRCUIT	<ul style="list-style-type: none"> <li>When a malfunction is detected in CAN communications</li> </ul>	X	U1000	U1000
STARTER RELAY/CIRC	<ul style="list-style-type: none"> <li>If this signal is ON other than in P or N position, this is judged to be a malfunction. (And if it is OFF in P or N position, this too is judged to be a malfunction.)</li> </ul>	X	P0615	—
PNP SW/CIRC	<ul style="list-style-type: none"> <li>PNP switch 1-4 signals input with impossible pattern</li> <li>P position is detected from N position without any other position being detected in between.</li> </ul>	X	P0705	P0705
VEH SPD SEN/CIR AT (Revolution sensor)	<ul style="list-style-type: none"> <li>Signal from vehicle speed sensor A/T(Revolution sensor) not input due to cut line or the like</li> <li>Unexpected signal input during running</li> <li>After ignition switch is turned ON, unexpected signal input from vehicle speed sensor MTR before the vehicle starts moving</li> </ul>	X	P0720	P0720
ENGINE SPEED SIG	<ul style="list-style-type: none"> <li>TCM does not receive the CAN communication signal from the ECM.</li> </ul>	X	P0725	P0725
TCC SOLENOID/CIRC	<ul style="list-style-type: none"> <li>Normal voltage not applied to solenoid due to cut line, short, or the like</li> </ul>	X	P0740	P0740
A/T TCC S/V FNCTN	<ul style="list-style-type: none"> <li>A/T cannot perform lock-up even if electrical circuit is good.</li> <li>TCM detects as irregular by comparing difference value with slip rotation.</li> </ul>	X	P0744	P0744*2

Items (CONSULT-II screen terms)	Malfunction is detected when...	TCM self-diagnosis		OBD-II (DTC)
		A/T CHECK indicator lamp	“A/T” with CONSULT-II	MIL indicator lamp*1, “ENGINE” with CONSULT-II or GST
L/PRESS SOL/CIRC	<ul style="list-style-type: none"> <li>● Normal voltage not applied to solenoid due to cut line, short, or the like</li> <li>● TCM detects as irregular by comparing target value with monitor value.</li> </ul>	X	P0745	P0745
TCM-POWER SUPPLY	<ul style="list-style-type: none"> <li>● When the power supply to the TCM is cut “OFF”, for example because the battery is removed, and the self-diagnostics memory function stops</li> <li>● This is not a malfunction message (Whenever shutting “OFF” a power supply to the TCM, this message appears on the screen.)</li> </ul>	—	P1701	—
TCM-RAM	<ul style="list-style-type: none"> <li>● TCM memory (RAM) is malfunctioning.</li> </ul>	—	P1702	—
TCM-ROM	<ul style="list-style-type: none"> <li>● TCM memory (ROM) is malfunctioning.</li> </ul>	—	P1703	—
TCM-EEPROM	<ul style="list-style-type: none"> <li>● TCM memory (EEP ROM) is malfunctioning.</li> </ul>	—	P1704	—
TP SEN/CIRC A/T	<ul style="list-style-type: none"> <li>● TCM does not receive the proper accelerator pedal position signals (input by CAN communication) from ECM.</li> </ul>	X	P1705	P1705
ATF TEMP SEN/CIRC	<ul style="list-style-type: none"> <li>● During running, the ATF temperature sensor signal voltage is excessively high or low</li> </ul>	X	P1710	P1710
TURBINE REV S/CIRC	<ul style="list-style-type: none"> <li>● TCM does not receive the proper voltage signal from the sensor.</li> <li>● TCM detects an irregularity only at position of 4th gear for turbine revolution sensor 2.</li> </ul>	X	P1716	P1716
VEH SPD SE/CIR-MTR	<ul style="list-style-type: none"> <li>● Signal (CAN communication) from vehicle speed sensor MTR not input due to cut line or the like</li> <li>● Unexpected signal input during running</li> </ul>	—	P1721	—
A/T INTERLOCK	<ul style="list-style-type: none"> <li>● Except during shift change, the gear position and pressure switch states are monitored and comparative judgement made.</li> </ul>	X	P1730	P1730
A/T 1ST E/BRAKING	<ul style="list-style-type: none"> <li>● Each pressure switch and solenoid current is monitored and if a pattern is detected having engine braking 1st gear other than in the M1 position, a malfunction is detected.</li> </ul>	X	P1731	—
I/C SOLENOID/CIRC	<ul style="list-style-type: none"> <li>● Normal voltage not applied to solenoid due to functional malfunction, cut line, short, or the like</li> <li>● TCM detects as irregular by comparing target value with monitor value.</li> </ul>	X	P1752	P1752
I/C SOLENOID FNCTN	<ul style="list-style-type: none"> <li>● TCM detects that actual gear ratio is irregular, and relation between gear position and condition of pressure switch 3 is irregular during depressing accelerator pedal. (Other than during shift change)</li> <li>● TCM detects that relation between gear position and condition of pressure switch 3 is irregular during releasing accelerator pedal. (Other than during shift change)</li> </ul>	X	P1754	P1754*2
FR/B SOLENOID/CIRC	<ul style="list-style-type: none"> <li>● Normal voltage not applied to solenoid due to functional malfunction, cut line, short, or the like</li> <li>● TCM detects as irregular by comparing target value with monitor value.</li> </ul>	X	P1757	P1757

Items (CONSULT-II screen terms)	Malfunction is detected when...	TCM self-diagnosis		OBD-II (DTC)
		A/T CHECK indicator lamp	“A/T” with CONSULT-II	MIL indicator lamp*1, “ENGINE” with CONSULT-II or GST
FR/B SOLENOID FNCT	<ul style="list-style-type: none"> <li>● TCM detects that actual gear ratio is irregular, and relation between gear position and condition of pressure switch 1 is irregular during depressing accelerator pedal. (Other than during shift change)</li> <li>● TCM detects that relation between gear position and condition of pressure switch 1 is irregular during releasing accelerator pedal. (Other than during shift change)</li> </ul>	X	P1759	P1759*2
D/C SOLENOID/ CIRC	<ul style="list-style-type: none"> <li>● Normal voltage not applied to solenoid due to cut line, short, or the like</li> <li>● TCM detects as irregular by comparing target value with monitor value.</li> </ul>	X	P1762	P1762
D/C SOLENOID FNCTN	<ul style="list-style-type: none"> <li>● TCM detects that actual gear ratio is irregular, and relation between gear position and condition of pressure switch 5 is irregular during depressing accelerator pedal. (Other than during shift change)</li> <li>● TCM detects that relation between gear position and condition of pressure switch 5 is irregular during releasing accelerator pedal. (Other than during shift change)</li> </ul>	X	P1764	P1764*2
HLR/C SOL/CIRC	<ul style="list-style-type: none"> <li>● Normal voltage not applied to solenoid due to functional malfunction, cut line, short, or the like</li> <li>● TCM detects as irregular by comparing target value with monitor value.</li> </ul>	X	P1767	P1767
HLR/C SOL FNCTN	<ul style="list-style-type: none"> <li>● TCM detects that actual gear ratio is irregular, and relation between gear position and condition of pressure switch 6 is irregular during depressing accelerator pedal. (Other than during shift change)</li> <li>● TCM detects that relation between gear position and condition of pressure switch 6 is irregular during releasing accelerator pedal. (Other than during shift change)</li> </ul>	X	P1769	P1769*2
LC/B SOLENOID/ CIRC	<ul style="list-style-type: none"> <li>● Normal voltage not applied to solenoid due to functional malfunction, cut line, short, or the like</li> </ul>	X	P1772	P1772
LC/B SOLENOID FNCT	<ul style="list-style-type: none"> <li>● TCM detects an improper voltage drop when it tries to operate the solenoid valve.</li> <li>● Condition of pressure switch 2 is different from monitor value, and relation between gear position and actual gear ratio is irregular.</li> </ul>	X	P1774	P1774*2
MANU MODE SW/ CIRC	<ul style="list-style-type: none"> <li>● When an impossible pattern of switch signals is detected, a malfunction is detected.</li> </ul>	—	P1815	—
ATF PRES SW 1/ CIRC	<ul style="list-style-type: none"> <li>● TCM detects that actual gear ratio is normal, and relation between gear position and condition of pressure switch 1 is irregular during depressing accelerator pedal. (Other than during shift change)</li> </ul>	—	P1841	—
ATF PRES SW 3/ CIRC	<ul style="list-style-type: none"> <li>● TCM detects that actual gear ratio is normal, and relation between gear position and condition of pressure switch 3 is irregular during depressing accelerator pedal. (Other than during shift change)</li> </ul>	—	P1843	—
ATF PRES SW 5/ CIRC	<ul style="list-style-type: none"> <li>● TCM detects that actual gear ratio is normal, and relation between gear position and condition of pressure switch 5 is irregular during depressing accelerator pedal. (Other than during shift change)</li> </ul>	—	P1845	—

A  
B  
**AT**  
D  
E  
F  
G  
H  
I  
J  
K  
L  
M

Items (CONSULT-II screen terms)	Malfunction is detected when...	TCM self-diagnosis		OBD-II (DTC)
		A/T CHECK indicator lamp	"A/T" with CONSULT-II	MIL indicator lamp*1, "ENGINE" with CONSULT-II or GST
ATF PRES SW 6/ CIRC	<ul style="list-style-type: none"> <li>TCM detects that actual gear ratio is normal, and relation between gear position and condition of pressure switch 6 is irregular during depressing accelerator pedal. (Other than during shift change)</li> </ul>	—	P1846	—
NO DTC IS DETECTED FURTHER TESTING MAY BE REQUIRED	<ul style="list-style-type: none"> <li>No NG item has been detected.</li> </ul>	—	X	X

\*1: Refer to [AT-38, "Malfunction Indicator Lamp \(MIL\)"](#) .

\*2: These malfunctions cannot be displayed MIL if another malfunction is assigned to MIL.

## Data monitor mode (A/T)

X: Standard, —: Not applicable

Monitored item (Unit)	Monitor Item Selection				Remarks
	ECU INPUT SIGNALS	MAIN SIGNALS	CAN DIAG SUPPORT MNTR	SELECTION FROM MENU	
VHCL/S SE-A/T (km/h)	X	X	—	X	Revolution sensor
VHCL/S SE-MTR (km/h)	X	—	—	X	
ACCELE POSI (0.0/8)	X	—	—	X	Accelerator pedal position signal
THROTTLE POSI (0.0/8)	X	X	—	X	Degree of opening for accelerator recognized by the TCM For fail-safe operation, the specific value used for control is displayed.
BATTERY BOLT (V)	X	—	—	X	
ENGINE SPEED (rpm)	X	X	—	X	
TURBINE REV (rpm)	X	X	—	X	
ATF TEMP 1 (°C)	—	X	—	X	
ATF TEMP 2 (°C)	—	X	—	X	
OUTPUT REV (rpm)	X	X	—	X	
ATF TEMP SE 1 (V)	X	—	—	X	
ATF TEMP SE 2 (V)	X	—	—	X	
ATF PRES SW 1 (ON-OFF display)	X	X	—	X	(for FR/B solenoid)
ATF PRES SW 2 (ON-OFF display)	X	X	—	X	(for LC/B solenoid)
ATF PRES SW 3 (ON-OFF display)	X	X	—	X	(for I/C solenoid)
ATF PRES SW 5 (ON-OFF display)	X	X	—	X	(for D/C solenoid)
ATF PRES SW 6 (ON-OFF display)	X	X	—	X	(for HLR/C solenoid)
PNP SW 1 (ON-OFF display)	X	—	—	X	
PNP SW 2 (ON-OFF display)	X	—	—	X	
PNP SW 3 (ON-OFF display)	X	—	—	X	
PNP SW 4 (ON-OFF display)	X	—	—	X	
1 POSITION SW (ON-OFF display)	X	—	—	X	
ASCD-CRUISE (ON-OFF display)	X	—	—	X	
ASCD-OD CUT (ON-OFF display)	X	—	—	X	



Monitored item (Unit)	Monitor Item Selection				Remarks
	ECU INPUT SIGNALS	MAIN SIGNALS	CAN DIAG SUP-PORT MNTR	SELECTION FROM MENU	
OD OFF SW (ON-OFF display)	X	—	—	X	Not mounted but displayed.
MANU MODE SW (ON-OFF display)	X	—	—	X	
NON M-MODE SW (ON-OFF display)	X	—	—	X	
UP SW LEVER (ON-OFF display)	X	—	—	X	
DOWN SW LEVER (ON-OFF display)	X	—	—	X	
POWER SHIFT SW (ON-OFF display)	X	—	—	X	Not mounted but displayed.
CLSD THL POS (ON-OFF display)	X	—	—	X	Signal input with CAN communications
W/O THL POS (ON-OFF display)	X	—	—	X	Signal input with CAN communications
TCC SOLENOID (A)	—	X	—	X	
LINE PRES SOL (A)	—	X	—	X	
I/C SOLENOID (A)	—	X	—	X	
FR/B SOLENOID (A)	—	X	—	X	
D/C SOLENOID (A)	—	X	—	X	
HLR/C SOL (A)	—	X	—	X	
HOLD SW (ON-OFF display)	X	—	—	X	Not mounted but displayed.
BRAKE SW (ON-OFF display)	X	—	—	X	Stop lamp switch
GEAR	—	X	—	X	Gear position recognized by the TCM updated after gear-shifting
GEAR RATIO	—	X	—	X	
SLCTLVR POSI	—	X	—	X	Selector lever position is recognized by the TCM. For fail safe operation, the specific value used for control is displayed.
VEHICLE SPEED (km/h)	—	X	—	X	Vehicle speed recognized by the TCM.
TC SLIP SPEED (rpm)	—	X	—	X	Difference between engine speed and torque converter input shaft speed
CAN COMM (OK-NG)	—	—	X	—	
CAN CIRC 1 (OK-UNKWN)	—	—	X	—	
CAN CIRC 2 (OK-UNKWN)	—	—	X	—	
CAN CIRC 3 (OK-UNKWN)	—	—	X	—	
CAN CIRC 4 (OK-UNKWN)	—	—	X	—	
CAN CIRC 5 (OK-UNKWN)	—	—	X	—	
Voltage (V)	—	—	—	X	Displays the value measured by the voltage probe.
F SUN GO REV (rpm)	—	—	—	X	
F CARR GR REV (rpm)	—	—	—	X	
SFT UP ST SW	—	—	—	X	Not mounted but displayed.
SFT DOWN ST SW	—	—	—	X	
ABS SIGNAL	—	—	—	X	

A  
B  
AT  
D  
E  
F  
G  
H  
I  
J  
K  
L  
M

Monitored item (Unit)	Monitor Item Selection				Remarks
	ECU INPUT SIGNALS	MAIN SIG- NALS	CAN DIAG SUP- PORT MNTR	SELEC- TION FROM MENU	
ACC OD CUT	—	—	—	X	Not mounted but displayed.
ACC SIGNAL	—	—	—	X	
TCS GR/P KEEP	—	—	—	X	
TCS SIGNAL 2	—	—	—	X	
TCS SIGNAL 1	—	—	—	X	
ON OFF SOL (ON-OFF display)	—	—	—	X	LC/B solenoid
TCC SOL MON	—	—	—	X	
L/P SOL MON	—	—	—	X	
I/C SL MON	—	—	—	X	
FR/B SOL MON	—	—	—	X	
D/C SOL MON	—	—	—	X	
HLR/C SOL MON	—	—	—	X	
ON OFF SOL MON	—	—	—	X	LC/B solenoid
P POSI IND	—	—	—	X	
R POSI IND	—	—	—	X	
N POSI IND	—	—	—	X	
D POSI IND	—	—	—	X	
4TH POSI IND	—	—	—	X	
3RD POSI IND	—	—	—	X	
2ND POSI IND	—	—	—	X	
1ST POSI IND	—	—	—	X	
M MODE IND	—	—	—	X	
POWER M LAMP	—	—	—	X	
F-SAFE IND/L	—	—	—	X	
ATF WARN LAMP	—	—	—	X	
BACK-UP LAMP	—	—	—	X	
STARTER RELAY	—	—	—	X	
PNP SW3 MON	—	—	—	X	
TRGT GR RATIO	—	—	—	X	
ENGINE TORQUE	—	—	—	X	
ENG TORQUE D	—	—	—	X	
INPUT TRQ S	—	—	—	X	
INPUT TRQ L/P	—	—	—	X	
TRGT PRES TCC	—	—	—	X	
TRGT PRES L/P	—	—	—	X	
TRGT PRES I/C	—	—	—	X	
TRGT PRES FR/B	—	—	—	X	
TRGT PRES D/C	—	—	—	X	
TRG PRE HLR/C	—	—	—	X	
SHIFT PATTERN	—	—	—	X	
C/V CLB ID1	—	—	—	X	

Monitored item (Unit)	Monitor Item Selection				Remarks
	ECU INPUT SIGNALS	MAIN SIGNALS	CAN DIAG SUP-PORT MNTR	SELECTION FROM MENU	
C/V CLB ID2	—	—	—	X	
C/V CLB ID3	—	—	—	X	
UNIT CLB ID1	—	—	—	X	
UNIT CLB ID2	—	—	—	X	
UNIT CLB ID3	—	—	—	X	
DRV CST JUDGE	—	—	—	X	
START RLY MON	—	—	—	X	
NEXT GR POSI	—	—	—	X	
SHIFT MODE	—	—	—	X	
MANU GR POSI	—	—	—	X	
Frequency (Hz)	—	—	—	X	The value measured by the pulse probe is displayed.
DUTY·HI (high) (%)	—	—	—	X	
DUTY·LOW (low) (%)	—	—	—	X	
PLS WIDTH·HI (ms)	—	—	—	X	
PLS WIDTH·LOW (ms)	—	—	—	X	

## DTC WORK SUPPORT MODE WITH CONSULT-II

### CONSULT-II setting procedure

**CAUTION:**

If CONSULT-II is used with no connection of CONSULT-II CONVERTER, malfunctions might be detected in self-diagnosis depending on control unit which carry out CAN communication.

- For details, refer to the separate “CONSULT-II Operation Manual”.
1. Turn ignition switch “OFF”.
  2. Connect CONSULT-II and CONSULT-II CONVERTER to data link connector, which is located in instrument lower panel on driver side.
  3. Turn ignition switch “ON”.(Do not start engine.)

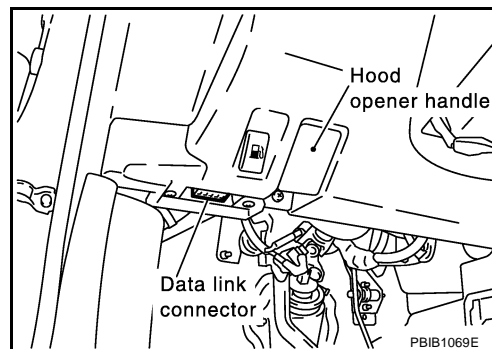

4. Touch “START(NISSAN BASED VHCL)”.

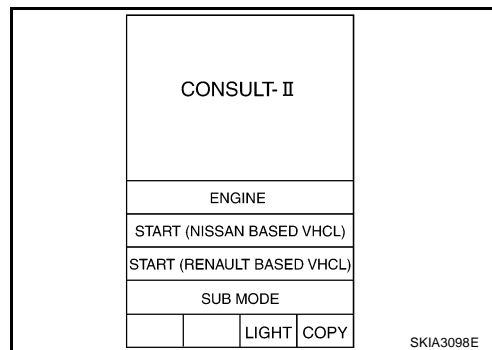

5. Touch "A/T".  
 If "A/T" is not indicated, go to [GI-39, "CONSULT-II Data Link Connector \(DLC\) Circuit"](#) .

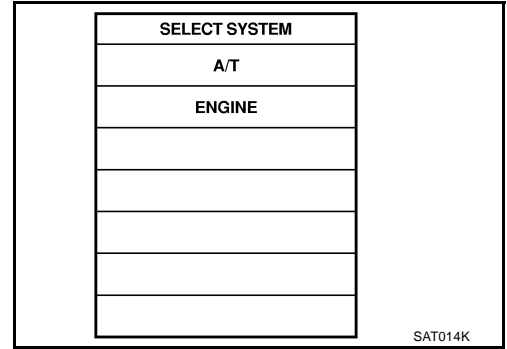

6. Touch "DTC WORK SUPPORT".

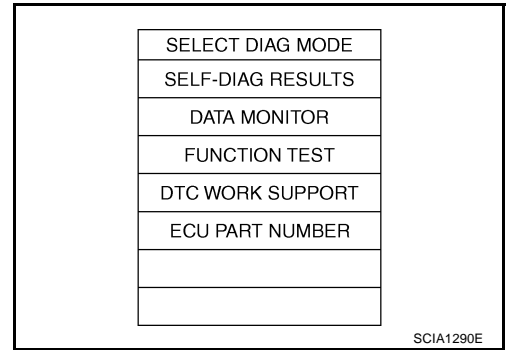

7. Touch select item menu.

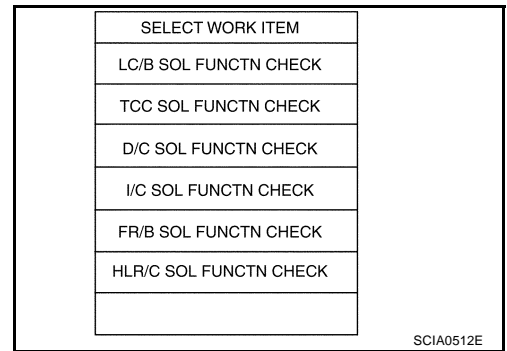

8. Touch "START".

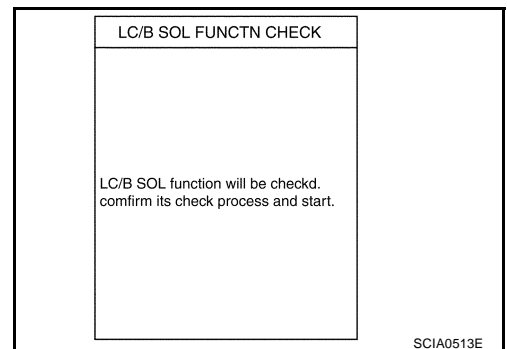

9. Perform driving test according to "DTC CONFIRMATION PROCEDURE" in "TROUBLE DIAGNOSIS FOR DTC".

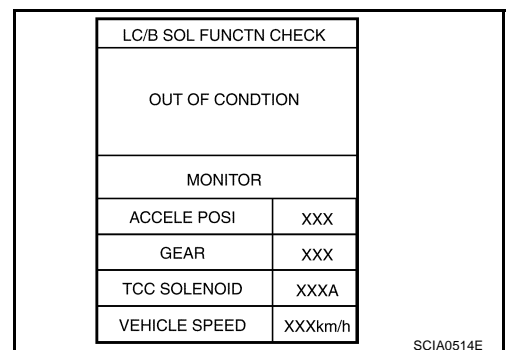

- When testing conditions are satisfied, CONSULT-II screen changes from “OUT OF CONDITION” to “TESTING”.

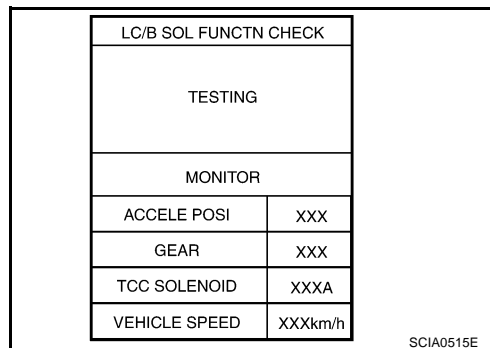

A  
B  
**AT**  
D

- Stop vehicle. If “NG” appears on the screen, malfunction may exist. Go to “DIAGNOSTIC PROCEDURE”.
- Perform test drive to check gear shift feeling in accordance with instructions displayed.
- Touch “YES” or “NO”.
- CONSULT-II procedure is ended.

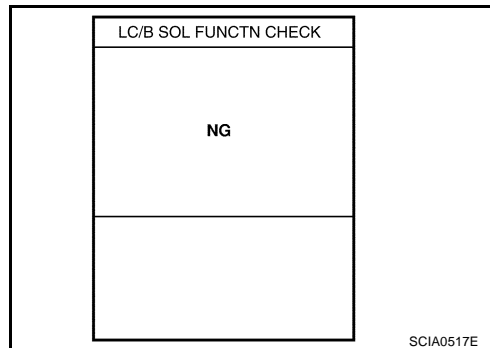

E  
F  
G

If “NG” appears on the screen, a malfunction may exist. Go to “DIAGNOSTIC PROCEDURE”.

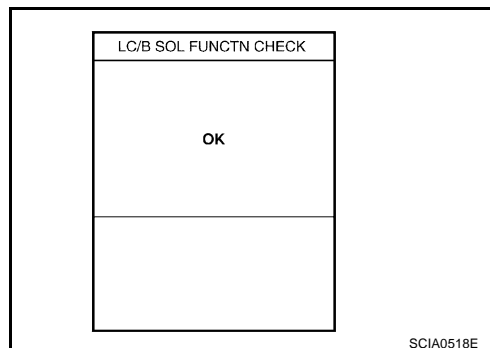

H  
I  
J  
K

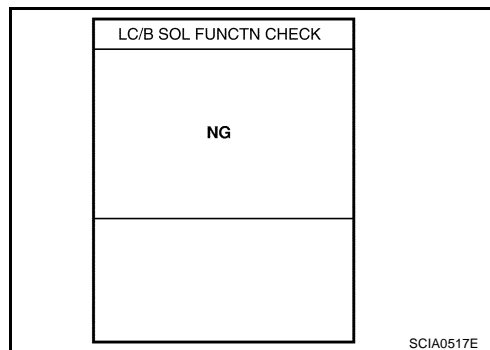

L  
M

## DTC WORK SUPPORT MODE

DTC work support item	Description	Check item
I/C SOL FUNCTN CHECK*	—	—
FR/B SOL FUNCTN CHECK*	—	—
D/C SOL FUNCTN CHECK*	—	—
HLR/C SOL FUNCTN CHECK*	—	—

DTC work support item	Description	Check item
LC/B SOL FUNCTN CHECK*	—	—
TCC SOL FUNCTN CHECK	Following items for “TCC solenoid function (lock-up)” can be confirmed. <ul style="list-style-type: none"> <li>● Self-diagnosis status (whether the diagnosis is being performed or not)</li> <li>● Self-diagnosis result (OK or NG)</li> </ul>	<ul style="list-style-type: none"> <li>● TCC solenoid valve</li> <li>● Hydraulic control circuit</li> </ul>

\*: Do not use, but displayed.

**Diagnostic Procedure Without CONSULT-II**  
**OBD-II SELF-DIAGNOSTIC PROCEDURE (WITH GST)**

ACS000HZ



A

Refer to [EC-116, "Generic Scan Tool \(GST\) Function"](#) .



B

**OBD-II SELF-DIAGNOSTIC PROCEDURE (NO TOOLS)**

Refer to [EC-62, "Malfunction Indicator Lamp \(MIL\)"](#) .



**TCM SELF-DIAGNOSTIC PROCEDURE (NO TOOLS)**

AT

**Description**

In the unlikely event of a malfunction in the electrical system, when the ignition switch is switched "ON", the A/T CHECK indicator lamp lights up for 2 seconds, then flashes for 8 seconds. If there is no malfunction, when the ignition switch is turned "ON", the indicator lamp lights up for 2 seconds. As a method for locating the suspect circuit, when the self-diagnostics start signal is input, the memory for the malfunction location is output and the A/T CHECK indicator lamp flashes to display the corresponding DTC.

D

E

**Diagnostic procedure**

**1. CHECK A/T CHECK INDICATOR LAMP**

1. Start the engine with selector lever in "P" position. Warm engine to normal operating temperature.
2. Turn ignition switch "ON" and "OFF" at least twice, then leave it in the "OFF" position.
3. Wait 10 seconds.
4. Turn ignition switch to "ON" position. (Do not start engine.)
5. Does A/T CHECK indicator lamp come on for about 2 seconds?

F

G

**YES or NO**

H

YES >> GO TO 2.

NO >> GO TO [AT-159, "A/T CHECK Indicator Lamp Does Not Come On"](#) .

**2. JUDGEMENT PROCEDURE STEP 1**

1. Turn ignition switch "OFF".
2. Push shift lock release button.
3. Move selector lever from "P" to "D" position.
4. Release accelerator pedal. (Set the closed throttle position signal "ON".)
5. Depress brake pedal. (Stop lamp switch signal "ON".)
6. Turn ignition switch "ON".
7. Wait 3 seconds.
8. Move the selector lever to the Manual shift gate side. (Manual mode switch "ON".)
9. Release brake pedal. (Stop lamp switch signal "OFF".)
10. Move the selector lever to "D" position. (Manual mode switch "OFF".)
11. Depress brake pedal. (Stop lamp switch signal "ON".)
12. Release brake pedal. (Stop lamp switch signal "OFF".)
13. Depress accelerator pedal fully and release it.

J

K

L

M

>> GO TO 3.

**3. CHECK SELF-DIAGNOSIS CODE**

Check A/T CHECK indicator lamp.

Refer to [AT-88, "Judgement self-diagnosis code"](#) .

If the system does not go into self-diagnostics. Refer to [AT-94, "DTC P0705 PARK/NEUTRAL POSITION SWITCH"](#) , [AT-112, "DTC P1705 THROTTLE POSITION SENSOR"](#) , [AT-145, "DTC P1815 MANUAL MODE SWITCH"](#) , [AT-158, "BRAKE SIGNAL CIRCUIT"](#) .

>> **DIAGNOSIS END**

## Judgement self-diagnosis code

If there is a malfunction, the lamp lights up for the time corresponding to the suspect circuit.

1	Revolution sensor 1
2	Direct clutch solenoid valve
3	Torque converter clutch solenoid valve
4	Line pressure solenoid valve
5	Input clutch solenoid valve
6	Front brake solenoid valve
7	Low coast brake solenoid valve
8	High & low reverse clutch solenoid valve
9	PNP switch
10	A/T fluid temperature sensor
11	Turbine revolution sensor
12	A/T interlock
13	A/T 1st engine braking
14	Start signal
15	Accelerator pedal position sensor
16	Engine speed signal
17	CAN

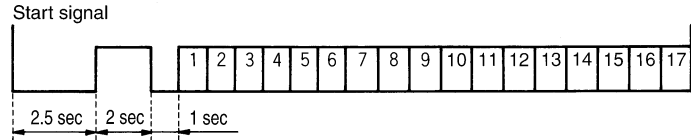

17-judgement flickers  
(OK)

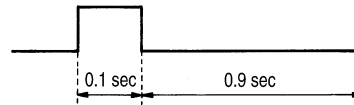

(NG)

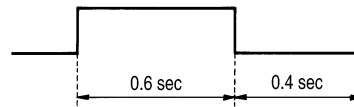

※ Solenoid valve is checked for open and short circuit, and malfunctions.

SCIA0497E

## Erase self-diagnosis

- In order to make it easier to find the cause of hard-to-duplicate malfunctions, malfunction information is stored into the control unit as necessary during use by the user. This memory is not erased no matter how many times the ignition switch is turned ON and OFF.
- However, this information is erased by turning ignition switch "OFF" after executing self-diagnostics or by erasing the memory using the CONSULT-II.



## DTC U1000 CAN COMMUNICATION LINE

PFP:23710

### Description

ACS003MG

CAN (Controller Area Network) is a serial communication line for real time application. It is an on-vehicle multiplex communication line with high data communication speed and excellent malfunction detection ability. Many electronic control units are equipped onto a vehicle, and each control unit shares information and links with other control units during operation (not independent). In CAN communication, control units are connected with 2 communication lines (CAN H line, CAN L line) allowing a high rate of information transmission with less wiring. Each control unit transmits/receives data but selectively reads required data only.

### On Board Diagnosis Logic

ACS003MH

- This is an OBD-II self-diagnostic item.
- Diagnostic trouble code "CAN COMM CIRCUIT" with CONSULT-II or U1000 without CONSULT-II is detected when TCM cannot communicate to other control units.

### Possible Cause

ACS003MI

Harness or connectors  
 (CAN communication line is open or shorted.)

### DTC Confirmation Procedure

ACS003MJ

#### NOTE:

If "DTC Confirmation Procedure" has been previously performed, always turn ignition switch "OFF" and wait at least 10 seconds before performing the next test.

After the repair, perform the following procedure to confirm the malfunction is eliminated.

#### ④ WITH CONSULT-II

1. Turn ignition switch "ON". (Do not start engine.)
2. Select "DATA MONITOR" mode for "ENGINE" with CONSULT-II.
3. Start engine and wait for at least 6 seconds.
4. If DTC is detected, go to [AT-90, "Diagnostic Procedure"](#).

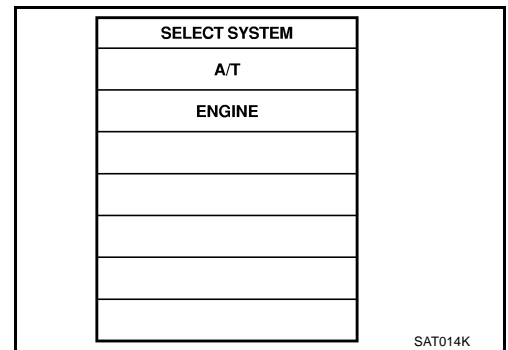

#### ④ WITH GST

Follow the procedure "WITH CONSULT-II".

## Diagnostic Procedure

### 1. CHECK CAN COMMUNICATION CIRCUIT

④ **With CONSULT-II**

1. Turn ignition switch "ON" and start engine.
2. Select "DATA MONITOR" mode for "A/T" with CONSULT-II.
3. The "CAN COMM CIRCUIT" is detected.

**YES or NO?**

- YES >> Print out CONSULT-II screen, GO TO 2.  
 NO >> **INSPECTION END**

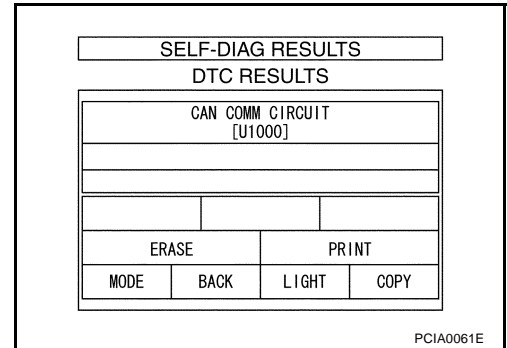

### 2. CHECK CAN COMMUNICATION SIGNALS

④ **With CONSULT-II**

1. Turn ignition switch "ON" and start engine.
2. Select "CAN DIAG SUPPORT MNTR" in "DATA MONITOR" mode for "A/T" with CONSULT-II.

>> Print out CONSULT-II screen, go to [LAN-3, "Precautions When Using CONSULT-II"](#) .

#### CAN Communication Signals

Normal conditions	Malfunction conditions (examples)
CAN COMM: OK	CAN COMM: OK
CAN CIRC 1: OK	CAN CIRC 1: UNKWN
CAN CIRC 2: OK	CAN CIRC 2: UNKWN
CAN CIRC 3: OK	CAN CIRC 3: UNKWN
CAN CIRC 4: OK	CAN CIRC 4: UNKWN
CAN CIRC 5: UNKWN	CAN CIRC 5: UNKWN

## DTC P0615 START SIGNAL CIRCUIT

PFP:25230

### Description

ACS00016

Prohibits cranking other at "P" or "N" position.

### On Board Diagnosis Logic

ACS00017

- This is not an OBD-II self-diagnostic item.
- Diagnostic trouble code "STARTER RELAY/CIRC" with CONSULT-II or 14th judgement flicker without CONSULT-II is detected when detects as irregular when switched "ON" other than at "P" or "N" position. (Or when switched "OFF" at "P" or "N" position).

### Possible Cause

ACS00018

- Harness or connectors  
(The starter relay and TCM circuit is open or shorted.)
- Starter relay circuit

### DTC Confirmation Procedure

ACS00019

#### NOTE:

If "DTC Confirmation Procedure" has been previously conducted, always turn ignition switch "OFF" and wait at least 10 seconds before conducting the next test.

After the repair, perform the following procedure to confirm the malfunction is eliminated.

#### Ⓟ WITH CONSULT-II

1. Turn ignition switch "ON". (Do not start engine.)
2. Select "DATA MONITOR" mode for "A/T" with CONSULT-II.
3. Start engine.
4. Vehicle start for at least 2 consecutive seconds.
5. If DTC is detected, go to [AT-92. "Diagnostic Procedure"](#).

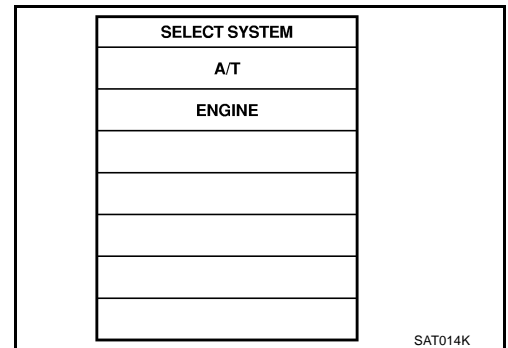

## Diagnostic Procedure

ACS000/B

### 1. CHECK STARTER RELAY

#### ④ With CONSULT-II

1. Turn ignition switch "ON". (Do not start engine.)
2. Select "SELECTION FROM MENU" in "DATA MONITOR" mode for "A/T" with CONSULT-II and check monitor "STARTER RELAY" ON/OFF.

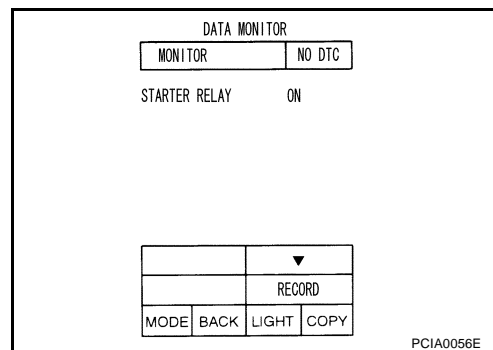

#### ⊗ Without CONSULT-II

1. Turn ignition switch "ON". (Do not start engine.)
2. Check the voltage between the IPDM E/R connector and ground.

Item	Connector No.	Terminal No. (Wiring color)	Shift position	Voltage (Approx.)
Starter relay	E9	53 (GY/R)	Ground	N and P Battery voltage
				R and D 0V

#### OK or NG

- OK >> GO TO 3.  
NG >> GO TO 2.

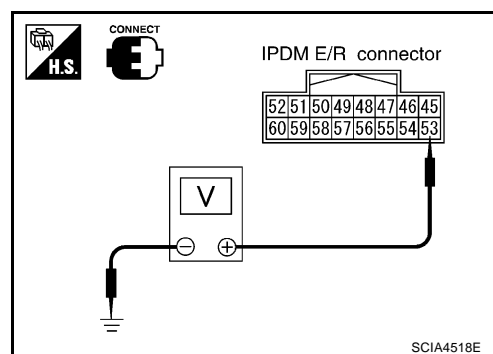

### 2. DETECT MALFUNCTIONING ITEM

Check the following items:

- Starter relay, Refer to [SC-10, "STARTING SYSTEM"](#) .
- Disconnections or short-circuits in the harness between TCM and the IPDM E/R.
- Disconnections or short-circuits in the harness between TCM and the unified meter and A/C amp.

#### OK or NG

- OK >> GO TO 3.  
NG >> Repair or replace damaged parts.

### 3. CHECK TCM

Perform TCM input/output signal inspection. Refer to [AT-74, "TCM Input/Output Signal Reference Values"](#) .

#### OK or NG

- OK >> GO TO 5.  
NG >> GO TO 4.

### 4. DETECT MALFUNCTIONING ITEM

Check the following items:

- Power supply and ground circuit for TCM.
- The TCM pin terminals for damage or loose connection with harness connector.

#### OK or NG

- OK >> Replace the transmission assembly. Refer to [AT-192, "Removal and Installation"](#) .  
NG >> Repair or replace damaged parts.

---

## 5. CHECK DTC

---

Perform DTC Confirmation Procedure.

- Refer to [AT-91, "DTC Confirmation Procedure"](#) .

OK or NG

OK >> **INSPECTION END**  
NG >> GO TO 3.

A

B

AT

D

E

F

G

H

I

J

K

L

M

## DTC P0705 PARK/NEUTRAL POSITION SWITCH

PDF:32006

### Description

ACS003ML

- The park/neutral position (PNP) switch includes a transmission range switch.
- The transmission range switch detects the selector lever position and sends a signal to the TCM.

### CONSULT-II Reference Value

ACS003MM

Item name	Condition	Display value
SLCTLVR POSI	Selector lever in "N", "P" position.	N/P
	Selector lever in "R" position.	R
	Selector lever in "D" position.	D

### On Board Diagnosis Logic

ACS003MN

- This is an OBD-II self-diagnostic item.
- Diagnostic trouble code "PNP SW/CIRC" with CONSULT-II or P0705 without CONSULT-II is detected under the following conditions.
  - When TCM does not receive the correct voltage signal from the PNP switch 1, 2, 3, 4 based on the gear position.
  - When no other position but "P" position is detected from "N" positions.

### Possible Cause

ACS003MO

- Harness or connectors  
 [The park/neutral position (PNP) switch 1, 2, 3, 4 and TCM circuit is open or shorted.]
- Park/neutral position (PNP) switch 1, 2, 3, 4

### DTC Confirmation Procedure

ACS003MP

#### CAUTION:

**Always drive vehicle at a safe speed.**

#### NOTE:

**If "DTC Confirmation Procedure" has been previously performed, always turn ignition switch "OFF" and wait at least 10 seconds before performing the next test.**

After the repair, perform the following procedure to confirm the malfunction is eliminated.

#### Ⓟ WITH CONSULT-II

1. Turn ignition switch "ON". (Do not start engine.)
2. Select "DATA MONITOR" mode for "ENGINE" with CONSULT-II.
3. Start engine.
4. Drive vehicle and maintain the following conditions for at least 2 consecutive seconds.  
**THRTL POS SEN: More than 1.2V**
5. If DTC is detected, go to [AT-95, "Diagnostic Procedure"](#).

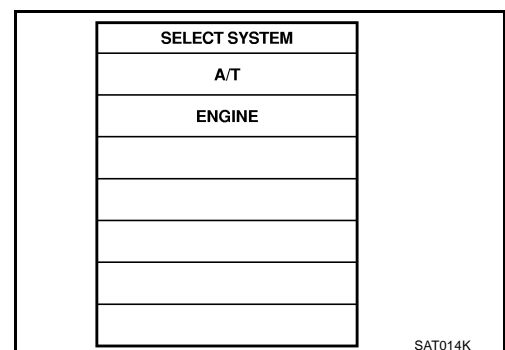

#### Ⓟ WITH GST

Follow the procedure "With CONSULT-II".

## Diagnostic Procedure

ACS003MQ

### 1. CHECK PNP SW CIRCUIT (WITH CONSULT-II)

**With CONSULT-II**

1. Turn ignition switch "ON". (Do not start engine.)
2. Select "MAIN SIGNALS" in "DATA MONITOR" mode for "A/T" with CONSULT-II.
3. Read out "N·P", "R" and "D" position switches moving selector lever to each position.

OK or NG

- OK     >> GO TO 4.  
 NG     >> GO TO 2.

DATA MONITOR			
MONITOR		NO DTC	
ATF PRES SW 2		OFF	
ATF PRES SW 3		OFF	
ATF PRES SW 5		OFF	
ATF PRES SW 6		OFF	
SLCT LVR POSI		N·P	

△	▽
RECORD	
MODE	BACK
LIGHT	COPY

PCIA0034E

### 2. CHECK TCM

Perform TCM input/output signal inspection. Refer to [AT-74, "TCM Input/Output Signal Reference Values"](#) .

OK or NG

- OK     >> GO TO 4.  
 NG     >> GO TO 3.

### 3. DETECT MALFUNCTIONING ITEM

Check the following items:

- Power supply and ground circuit for TCM.
- A/T assembly harness connector pin terminals for damage or loose connection with harness connector.

OK or NG

- OK     >> Replace the transmission assembly. Refer to [AT-192, "Removal and Installation"](#) .  
 NG     >> Repair or replace damaged parts.

### 4. CHECK DTC

Perform DTC Confirmation Procedure.

- Refer to [AT-94, "DTC Confirmation Procedure"](#) .

OK or NG

- OK     >> **INSPECTION END**  
 NG     >> GO TO 2.

## DTC P0720 VEHICLE SPEED SENSOR A/T (REVOLUTION SENSOR)

PFP:32702

### Description

ACS003MR

The revolution sensor detects the revolution of the idler gear parking pawl lock gear and emits a pulse signal. The pulse signal is sent to the TCM which converts it into vehicle speed.

### CONSULT-II Reference Value

ACS003MS

Item name	Condition	Display value (km/h)
VHCL/S SE-A/T	During driving	Approximately matches the speedometer reading.

### On Board Diagnosis Logic

ACS003MT

- This is an OBD-II self-diagnostic item.
- Diagnostic trouble code “VEH SPD SEN/CIR AT” with CONSULT-II or P0720 without CONSULT-II is detected under the following conditions.
  - When TCM does not receive the proper voltage signal from the sensor.
  - After ignition switch is turned “ON”, irregular signal input from vehicle speed sensor MTR before the vehicle starts moving.

### Possible Cause

ACS003MU

- Harness or connectors  
(The sensor circuit is open or shorted.)
- Revolution sensor
- Vehicle speed sensor MTR

### DTC Confirmation Procedure

ACS003MV

#### CAUTION:

- Always drive vehicle at a safe speed.
- Be careful not to rev engine into the red zone on the tachometer.

#### NOTE:

If “DTC Confirmation Procedure” has been previously performed, always turn ignition switch “OFF” and wait at least 10 seconds before performing the next test.

After the repair, perform the following procedure to confirm the malfunction is eliminated.

#### WITH CONSULT-II

1. Turn ignition switch “ON”. (Do not start engine.)
2. Select “DATA MONITOR” mode for “A/T” with CONSULT-II.
3. Drive vehicle and check for an increase of “VHCL/S SE-A/T” value in response to “VHCL/S SE-MTR” value.  
If the check result is NG, go to [AT-97, "Diagnostic Procedure"](#) .  
If the check result is OK, go to following step.
4. Select “DATA MONITOR” mode for “ENGINE” with CONSULT-II.
5. Start engine and maintain the following conditions for at least 5 consecutive seconds.

**VHCL SPEED SE: 30 km/h (19 MPH) or more**

**THRTL POS SEN: More than 1.0/8**

**Selector lever: “D” position**

**Driving location: Driving the vehicle uphill (increased engine load) will help maintain the driving conditions required for this test.**

If the check result is NG, go to [AT-97, "Diagnostic Procedure"](#) .

If the check result is OK, go to following step.

6. Maintain the following conditions for at least 5 consecutive seconds.

**ENGINE SPEED: 3,500 rpm or more**

**THRTL POS SEN: More than 1.0/8**

**Selector lever: “D” position**

**Driving location: Driving the vehicle uphill (increased engine load) will help maintain the driving conditions required for this test.**

If the check result is NG, go to [AT-97, "Diagnostic Procedure"](#) .

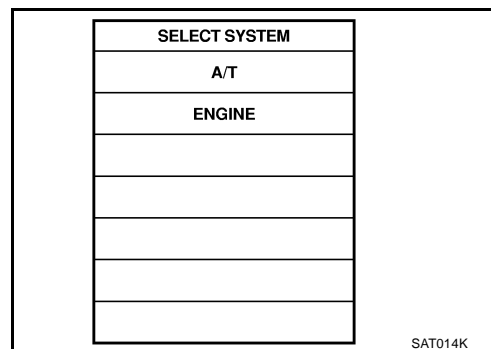



**WITH GST**

Follow the procedure "With CONSULT-II".

## Diagnostic Procedure

ACS003MW

### 1. CHECK INPUT SIGNALS

**With CONSULT-II**

1. Turn ignition switch "ON". (Do not start engine.)
2. Select "ECU INPUT SIGNALS" in "DATA MONITOR" mode for "A/T" with CONSULT-II.
3. Start the engine.
4. Read out the value of "VHCL/S SE·A/T" while driving. Check the value changes according to driving speed.

DATA MONITOR			
MONITOR		NO DTC	
VHCL/S SE-A/T	0km/h		
VHCL/S SE-MTR	0km/h		
ACCELE POSI	0.0/8		
THROTTLE POS	0.0/8		
CLSD THL POS	ON		
W/O THL POS	OFF		
		▽	
		RECORD	
MODE	BACK	LIGHT	COPY

SCIA2148E

OK or NG

- OK >> GO TO 4.  
 NG >> GO TO 2.

### 2. CHECK TCM

Perform TCM input/output signal inspection. Refer to [AT-74, "TCM Input/Output Signal Reference Values"](#) .

OK or NG

- OK >> GO TO 4.  
 NG >> GO TO 3.

### 3. DETECT MALFUNCTIONING ITEM

Check the following items:

- Power supply and ground circuit for TCM.
- The A/T assembly harness connector pin terminals for damage or loose connection with harness connector.

OK or NG

- OK >> Replace the transmission assembly. Refer to [AT-192, "Removal and Installation"](#) .  
 NG >> Repair or replace damaged parts.

### 4. CHECK DTC

Perform DTC Confirmation Procedure.

- Refer to [AT-96, "DTC Confirmation Procedure"](#) .

OK or NG

- OK >> **INSPECTION END**  
 NG >> GO TO 2.

## DTC P0725 ENGINE SPEED SIGNAL

PFP:24825

### Description

ACS003MX

The engine speed signal is sent from the ECM to the TCM.

### CONSULT-II Reference Value

ACS003MY

Item name	Condition	Display value (rpm)
ENGINE SPEED	Engine running	Closely matches the tachometer reading.

### On Board Diagnosis Logic

ACS003MZ

- This is an OBD-II self-diagnostic item.
- Diagnostic trouble code “ENGINE SPEED SIG” with CONSULT-II or P0725 without CONSULT-II is detected when TCM does not receive the ignition signal from ECM during engine cranking or running.

### Possible Cause

ACS003N0

Harness or connectors  
 (The ECM to the TCM circuit is open or shorted.)

### DTC Confirmation Procedure

ACS003N1

#### CAUTION:

**Always drive vehicle at a safe speed.**

#### NOTE:

If “DTC Confirmation Procedure” has been previously performed, always turn ignition switch “OFF” and wait at least 10 seconds before performing the next test.

After the repair, perform the following procedure to confirm the malfunction is eliminated.

#### WITH CONSULT-II

1. Turn ignition switch “ON” and select “DATA MONITOR” mode for “A/T” with CONSULT-II.
2. Start engine and maintain the following conditions for at least 10 consecutive seconds.  
**VHCL SPEED SE: 10 km/h (6 MPH) or more**  
**ACCELE POSI: More than 1/8**  
**Selector lever: “D” position**
3. If DTC is detected, go to [AT-98, "Diagnostic Procedure"](#).

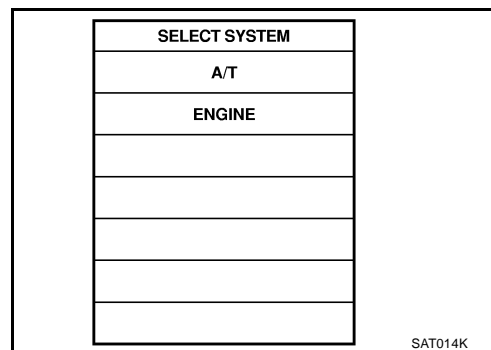

#### WITH GST

Follow the procedure “With CONSULT-II”.

### Diagnostic Procedure

ACS003N2

#### 1. CHECK CAN COMMUNICATION LINE

Perform the self-diagnosis. Refer to [AT-76, "SELF-DIAGNOSTIC PROCEDURE \(WITH CONSULT-II\)"](#) , [AT-87, "TCM SELF-DIAGNOSTIC PROCEDURE \(NO TOOLS\)"](#) .

Is a malfunction in the CAN communication indicated in the results?

- YES >> Check CAN communication line. Refer to [AT-89, "DTC U1000 CAN COMMUNICATION LINE"](#) .  
 NO >> GO TO 2.

## 2. CHECK DTC WITH TCM

### With CONSULT-II

1. Start engine.
2. Select "ECU INPUT SIGNALS" in "DATA MONITOR" mode for "A/T" with CONSULT-II.
3. While monitoring engine speed, check for engine speed change corresponding to wide-open throttle position signal.

DATA MONITOR	
MONITOR	NO DTC
W/O THL POS	OFF
BRAKE SW	OFF
ENGINE SPEED	0 rpm
TURBINE REV	0 rpm
OUTPUT REV	0 rpm
▼	
RECORD	
MODE	BACK LIGHT COPY

PCIA0041E

### With GST

Follow the procedure "With CONSULT-II".

#### OK or NG

- OK >> GO TO 3.
- NG >> Check the ignition signal circuit.
  - Refer to [EC-571, "IGNITION SIGNAL"](#) .

## 3. CHECK TCM

Perform TCM input/output signal inspection. Refer to [AT-74, "TCM Input/Output Signal Reference Values"](#) .

#### OK or NG

- OK >> GO TO 5.
- NG >> GO TO 4.

## 4. DETECT MALFUNCTIONING ITEM

Check the following items:

- Power supply and ground circuit for TCM.
- The A/T assembly harness connector pin terminals for damage or loose connection with harness connector.

#### OK or NG

- OK >> Replace the transmission assembly. Refer to [AT-192, "Removal and Installation"](#) .
- NG >> Repair or replace damaged parts.

## 5. CHECK DTC

Perform DTC Confirmation Procedure.

- Refer to [AT-98, "DTC Confirmation Procedure"](#) .

#### OK or NG

- OK >> **INSPECTION END**
- NG >> GO TO 3.

## DTC P0740 TORQUE CONVERTER CLUTCH SOLENOID VALVE

PFP:31940

### Description

ACS003N3

- The torque converter clutch solenoid valve is activated, with the gear in D4 , D5 by the TCM in response to signals sent from the vehicle speed sensor and accelerator pedal position sensor (throttle position sensor). Torque converter clutch piston operation will then be controlled.
- Lock-up operation, however, is prohibited when A/T fluid temperature is too low.
- When the accelerator pedal is depressed (less than 1/8) in lock-up condition, the engine speed should not change abruptly. If there is a big jump in engine speed, there is no lock-up.

### CONSULT-II Reference Value

ACS003N4

Item name	Condition	Display value (Approx.) (A)
TCC SOLENOID	When performing slip lock-up	0.2 - 0.4
	When performing lock-up	0.4 - 0.6

### On Board Diagnosis Logic

ACS003N5

- This is an OBD-II self-diagnostic item.
- Diagnostic trouble code "TCC SOLENOID/CIRC" with CONSULT-II or P0740 without CONSULT-II is detected under the following conditions.
  - When TCM detects an improper voltage drop when it tries to operate the solenoid valve.
  - When TCM detects as irregular by comparing target value with monitor value.

### Possible Cause

ACS003N6

- Torque converter clutch solenoid valve
- Harness or connectors  
(The solenoid circuit is open or shorted.)

### DTC Confirmation Procedure

ACS003N7

#### CAUTION:

**Always drive vehicle at a safe speed.**

#### NOTE:

**If "DTC Confirmation Procedure" has been previously performed, always turn ignition switch "OFF" and wait at least 10 seconds before performing the next test.**

After the repair, perform the following procedure to confirm the malfunction is eliminated.

#### WITH CONSULT-II

1. Turn ignition switch "ON". (Do not start engine.)
2. Select "DATA MONITOR" mode for "ENGINE" with CONSULT-II.
3. Start engine and maintain the following conditions for at least 5 consecutive seconds.
  - VHCL SPEED SE: 80 km/h (50 MPH) or more**
  - ACCELE POSI: 0.5/8 - 1.0/8**
  - SELECTOR LEVER: "D" position**
  - Driving location: Driving the vehicle uphill (increased engine load) will help maintain the driving conditions required for this test.**
4. If DTC is detected go to [AT-101, "Diagnostic Procedure"](#) .

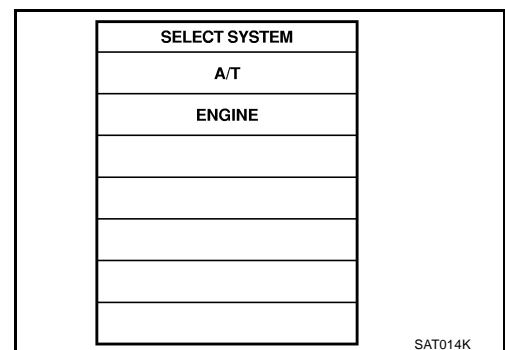

#### WITH GST

Follow the procedure "With CONSULT-II".

## Diagnostic Procedure

ACS003NB

### 1. CHECK TCM

Perform TCM input/output signal inspection. Refer to [AT-74, "TCM Input/Output Signal Reference Values"](#).

OK or NG

- OK >> GO TO 3.
- NG >> GO TO 2.

### 2. DETECT MALFUNCTIONING ITEM

Check the following items:

- Power supply and ground circuit for TCM.
- The A/T assembly harness connector pin terminals for damage or loose connection with harness connector.

OK or NG

- OK >> Replace the transmission assembly. Refer to [AT-192, "Removal and Installation"](#).
- NG >> Repair or replace damaged parts.

### 3. CHECK DTC

Perform DTC Confirmation Procedure.

- Refer to [AT-100, "DTC Confirmation Procedure"](#).

OK or NG

- OK >> **INSPECTION END**
- NG >> GO TO 1.

A

B

AT

D

E

F

G

H

I

J

K

L

M

## DTC P0744 A/T TCC S/V FUNCTION (LOCK-UP)

PF3:31940

### Description

ACS003N9

This malfunction is detected when the A/T does not shift into 5th gear position or the torque converter clutch does not lock-up as instructed by the TCM. This is not only caused by electrical malfunction (circuits open or shorted) but also by mechanical malfunction such as control valve sticking, improper solenoid valve operation, etc.

### CONSULT-II Reference Value

ACS003NA

Item name	Condition	Display value (Approx.) (A)
TCC SOLENOID	When performing slip lock-up	0.2 - 0.4
	When performing lock-up	0.4 - 0.6

### On Board Diagnosis Logic

ACS003NB

- This is an OBD-II self-diagnostic item.
- Diagnostic trouble code "A/T TCC S/V FNCTN" with CONSULT-II or P0744 without CONSULT-II is detected under the following conditions.
  - When A/T cannot perform lock-up even if electrical circuit is good.
  - When TCM detects as irregular by comparing difference value with slip rotation.

### Possible Cause

ACS003NC

- Harness or connectors  
(The solenoid circuit is open or shorted.)
- Torque converter clutch solenoid valve
- Hydraulic control circuit

### DTC Confirmation Procedure

ACS003ND

#### CAUTION:

Always drive vehicle at a safe speed.

#### NOTE:

If "DTC Confirmation Procedure" has been previously performed, always turn ignition switch "OFF" and wait at least 10 seconds before performing the next test.

After the repair, perform the following procedure to confirm the malfunction is eliminated.

#### WITH CONSULT-II

1. Start engine and Select "TCC SOL FUNCTN CHECK" of "DTC WORK SUPPORT" mode for "A/T" with CONSULT-II and touch "START".
2. Accelerate vehicle to more than 80 km/h (50 MPH) and maintain the following condition continuously until "TESTING" has turned to "COMPLETE". (It will take approximately 30 seconds after "TESTING" shows.)

**ACCELE POSI: More than 1.0/8 (at all times during step 4)**

**TCC SOLENOID: 0.4 - 0.6 A**

**Selector lever: "D" position**

**[Reference speed: Constant speed of more than 80 km/h (50 MPH)]**

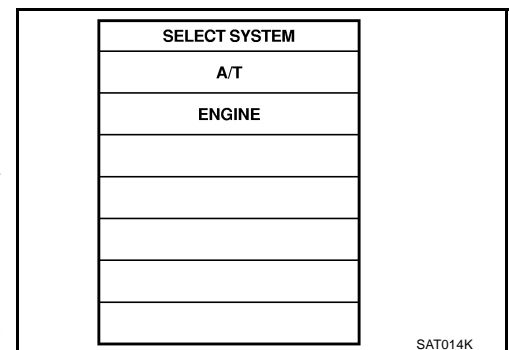

- Make sure "GEAR" shows "5".
  - For shift schedule, refer to [AT-65. "Vehicle Speed When Performing and Releasing Complete Lock-up"](#).
  - If "TESTING" does not appear on CONSULT-II for a long time, select "SELF-DIAG RESULTS". In case a 1st trip DTC other than P0744 is shown, refer to applicable "TROUBLE DIAGNOSIS FOR DTC".
3. Make sure that "OK" is displayed. (If "NG" is displayed, refer to "DIAGNOSTIC PROCEDURE".)  
 Refer to [AT-103. "Diagnostic Procedure"](#).  
 Refer to shift schedule, [AT-65. "Vehicle Speed When Performing and Releasing Complete Lock-up"](#).

 **WITH GST**

Follow the procedure "With CONSULT-II".

## Diagnostic Procedure

ACS003NE

### 1. CHECK TCM

Perform TCM input/output signal inspection. Refer to [AT-74, "TCM Input/Output Signal Reference Values"](#) .

OK or NG

- OK >> GO TO 3.
- NG >> GO TO 2.

### 2. DETECT MALFUNCTIONING ITEM

Check the following items:

- Power supply and ground circuit for TCM.
- The A/T assembly harness connector pin terminals for damage or loose connection with harness connector.

OK or NG

- OK >> Replace the transmission assembly. Refer to [AT-192, "Removal and Installation"](#) .
- NG >> Repair or replace damaged parts.

### 3. CHECK DTC

Perform DTC Confirmation Procedure.

- Refer to [AT-102, "DTC Confirmation Procedure"](#) .

OK or NG

- OK >> **INSPECTION END**
- NG >> GO TO 1.

A  
B  
AT  
D  
E  
F  
G  
H  
I  
J  
K  
L  
M

## DTC P0745 LINE PRESSURE SOLENOID VALVE

PFP:31940

### Description

ACS003NF

The line pressure solenoid valve regulates the oil pump discharge pressure to suit the driving condition in response to a signal sent from the TCM.

**The line pressure duty cycle value is not consistent when the closed throttle position signal is “ON”. To confirm the line pressure duty cycle at low pressure, the accelerator (throttle) should be open until the closed throttle position signal is “OFF”.**

### CONSULT-II Reference Value

ACS003NG

Item name	Condition	Display value (Approx.) (A)
LINE PRES SOL	During driving	0.2 - 0.6

### On Board Diagnosis Logic

ACS003NH

- This is an OBD-II self-diagnostic item.
- Diagnostic trouble code “L/PRESS SOL/CIRC” with CONSULT-II or P0745 without CONSULT-II is detected under the following conditions.
  - When TCM detects an improper voltage drop when it tries to operate the solenoid valve.
  - When TCM detects as irregular by comparing target value with monitor value.

### Possible Cause

ACS003NI

- Harness or connectors  
(The solenoid circuit is open or shorted.)
- Line pressure solenoid valve

### DTC Confirmation Procedure

ACS003NJ

#### NOTE:

**If “DTC Confirmation Procedure” has been previously performed, always turn ignition switch “OFF” and wait at least 10 seconds before performing the next test.**

After the repair, perform the following procedure to confirm the malfunction is eliminated.

#### Ⓜ WITH CONSULT-II

1. Turn ignition switch “ON” and select “DATA MONITOR” mode for “ENGINE” with CONSULT-II.
2. Engine start and wait at least 5 second.
3. If DTC is detected, go to [“AT-105, "Diagnostic Procedure" .](#)

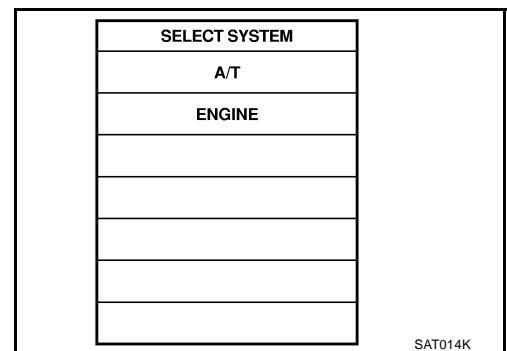

#### Ⓜ WITH GST

Follow the procedure “With CONSULT-II”.



## Diagnostic Procedure

ACS003NK

### 1. CHECK TCM

Perform TCM input/output signal inspection. Refer to [AT-74, "TCM Input/Output Signal Reference Values"](#) .

OK or NG

- OK >> GO TO 3.
- NG >> GO TO 2.

### 2. DETECT MALFUNCTIONING ITEM

Check the following items:

- Power supply and ground circuit for TCM.
- The A/T assembly harness connector pin terminals for damage or loose connection with harness connector.

OK or NG

- OK >> Replace the transmission assembly. Refer to [AT-192, "Removal and Installation"](#) .
- NG >> Repair or replace damaged parts.

### 3. CHECK DTC

Perform DTC Confirmation Procedure.

- Refer to [AT-104, "DTC Confirmation Procedure"](#) .

OK or NG

- OK >> **INSPECTION END**
- NG >> GO TO 1.

A

B

AT

D

E

F

G

H

I

J

K

L

M

## DTC P1701 TRANSMISSION CONTROL MODULE (POWER SUPPLY)

PFP:31036

### Description

ACS003NL

When the power supply to the TCM is cut "OFF", for example because the battery is removed, and the self-diagnostics memory function stops, malfunction is detected.

### On Board Diagnosis Logic

ACS003NM

- This is not an OBD-II self-diagnostic item.
- Diagnostic trouble code "TCM-POWER SUPPLY" with CONSULT-II is detected when TCM does not receive the voltage signal from the battery power supply.
- This is not a malfunction message. (Whenever shutting "OFF" a power supply to the TCM, this message appears on the screen.)

### Possible Cause

ACS003NN

Harness or connectors  
(Battery or ignition switch and TCM circuit is open or shorted.)

### DTC Confirmation Procedure

ACS003NO

#### NOTE:

If "DTC Confirmation Procedure" has been previously performed, always turn ignition switch "OFF" and wait at least 10 seconds before performing the next test.

After the repair, perform the following procedure to confirm the malfunction is eliminated.

#### WITH CONSULT-II

1. Turn ignition switch "ON". (Do not start engine.)
2. Select "DATA MONITOR" mode for "A/T" with CONSULT-II.
3. Wait for at least 2 consecutive seconds.
4. If DTC is detected, go to [AT-106. "Diagnostic Procedure"](#).

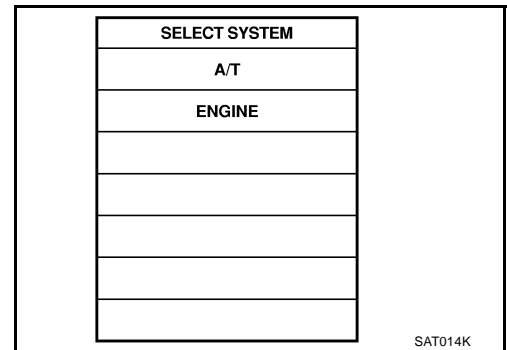

ACS003NP

### Diagnostic Procedure

#### 1. CHECK TCM POWER SOURCE STEP 1

1. Turn ignition switch "OFF".
2. Disconnect A/T assembly harness connector.
3. Check voltage between A/T assembly harness connector and ground. Refer to [AT-49, "Wiring Diagram — AT —"](#).

Item	Connector No.	Terminal No. (Wire color)	Voltage
TCM	F6	1 (R/W) - Ground	Battery voltage
		2 (R/W) - Ground	
		6 (Y/R) - Ground	0V

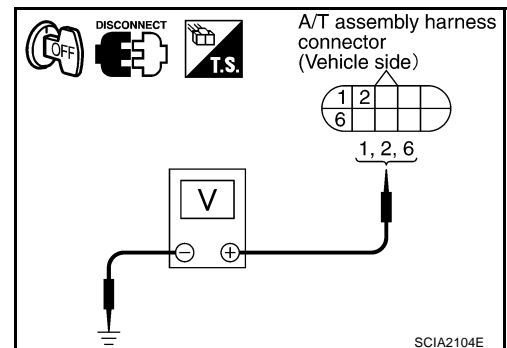

SCIA2104E

#### OK or NG

- OK >> GO TO 2.  
NG >> GO TO 3.

## 2. CHECK TCM POWER SOURCE STEP 2

1. Disconnect A/T assembly harness connector.
2. Turn ignition switch "ON". (Do not start engine.)
3. Check voltage between A/T assembly harness connector and ground. Refer to [AT-49, "Wiring Diagram — AT —"](#).

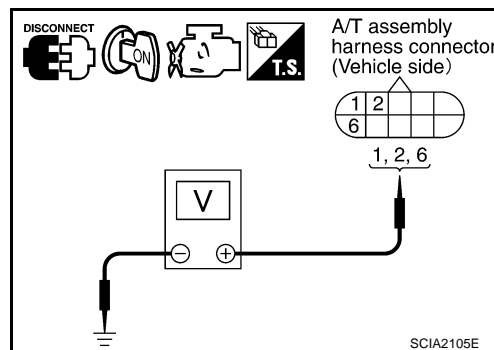

Item	Connector No.	Terminal No. (Wire color)	Voltage
TCM	F6	1 (R/W) - Ground	Battery voltage
		2 (R/W) - Ground	
		6 (Y/R) - Ground	

### OK or NG

- OK >> GO TO 4.
- NG >> GO TO 3.

## 3. DETECT MALFUNCTIONING ITEM

Check the following items:

- Harness for short or open between battery and A/T assembly harness connector terminals 1, 2
- Harness for short or open between ignition switch and A/T assembly harness connector terminal 6
- 10A fuse (No. 32, located in the fuse and fusible link block) and 10A fuse (No. 83, located in the IPDM E/R)
- Ignition switch, Refer to [PG-4, "POWER SUPPLY ROUTING CIRCUIT"](#)

### OK or NG

- OK >> GO TO 4.
- NG >> Repair or replace damaged parts.

## 4. CHECK TCM GROUND CIRCUIT

1. Turn ignition switch "OFF".
2. Disconnect A/T assembly harness connector.
3. Check continuity between A/T assembly harness connector terminal 5 (B), 10 (B) and ground. Refer to [AT-49, "Wiring Diagram — AT —"](#).

**Continuity should exist.**

If OK, check harness for short to ground and short to power.

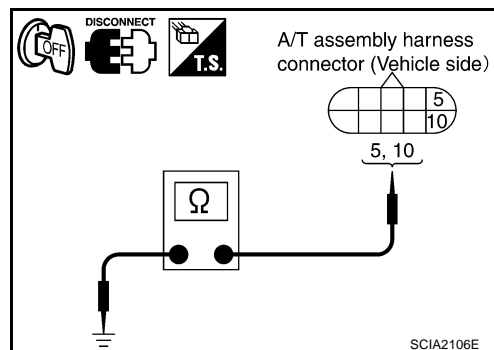

### OK or NG

- OK >> GO TO 5.
- NG >> Repair open circuit or short to ground or short to power in harness or connectors.

## 5. CHECK DTC

Perform DTC Confirmation Procedure.

- Refer to [AT-106, "DTC Confirmation Procedure"](#).

### OK or NG

- OK >> **INSPECTION END**
- NG >> GO TO 6.

---

## 6. DETECT MALFUNCTIONING ITEM

---

The A/T assembly harness connector pin terminals for damage or loose connection with harness connector.

### OK or NG

- OK >> Replace the transmission assembly. Refer to [AT-192. "Removal and Installation"](#) .
- NG >> Repair or replace damaged parts.

## DTC P1702 TRANSMISSION CONTROL MODULE (RAM)

PF3:31036

### Description

ACS003NQ

The TCM consists of a microcomputer and connectors for signal input and output and for power supply. The TCM controls the A/T.

### On Board Diagnosis Logic

ACS003NR

- This is not an OBD-II self-diagnostic item.
- Diagnostic trouble code "TCM-RAM" with CONSULT-II is detected when TCM memory RAM is malfunctioning.

### Possible Cause

ACS003NS

TCM.

### DTC Confirmation Procedure

ACS003NT

#### NOTE:

If "DTC Confirmation Procedure" has been previously performed, always turn ignition switch "OFF" and wait at least 10 seconds before performing the next test.

After the repair, perform the following procedure to confirm the malfunction is eliminated.

#### WITH CONSULT-II

1. Turn ignition switch "ON". (Do not start engine.)
2. Select "DATA MONITOR" mode for "A/T" with CONSULT-II.
3. Start engine.
4. Run engine for at least 2 consecutive seconds at idle speed.
5. If DTC is detected, go to [AT-109, "Diagnostic Procedure"](#).

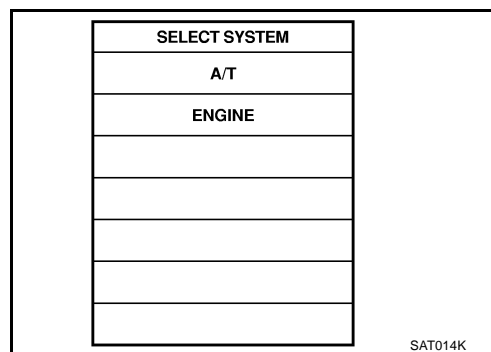

### Diagnostic Procedure

ACS003NU

#### 1. CHECK DTC

#### With CONSULT-II

1. Turn ignition switch "ON". (Do not start engine.)
2. Select "SELF DIAG RESULTS" mode for "A/T" with CONSULT-II.
3. Touch "ERASE".
4. Turn ignition switch "OFF" and wait at least 10 seconds.
5. Perform DTC confirmation procedure, [AT-109, "DTC Confirmation Procedure"](#).

Is the "TCM-RAM" displayed again?

- YES >> Replace the transmission assembly. Refer to [AT-192, "Removal and Installation"](#).
- NO >> **INSPECTION END**

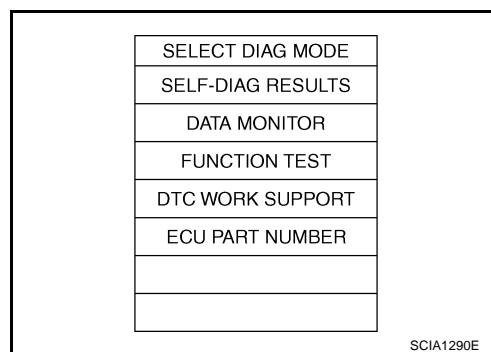

## DTC P1703 TRANSMISSION CONTROL MODULE (ROM)

PF3:31036

### Description

ACS003NV

The TCM consists of a microcomputer and connectors for signal input and output and for power supply. The TCM controls the A/T.

### On Board Diagnosis Logic

ACS003NW

- This is not an OBD-II self-diagnostic item.
- Diagnostic trouble code "TCM-ROM" with CONSULT-II is detected when TCM memory ROM is malfunctioning.

### Possible Cause

ACS003NX

TCM.

### DTC Confirmation Procedure

ACS003NY

#### NOTE:

If "DTC Confirmation Procedure" has been previously performed, always turn ignition switch "OFF" and wait at least 10 seconds before performing the next test.

After the repair, perform the following procedure to confirm the malfunction is eliminated.

#### Ⓜ WITH CONSULT-II

1. Turn ignition switch to "ON". (Do not start engine.)
2. Select "DATA MONITOR" mode for A/T with CONSULT-II.
3. Start engine.
4. Run engine for at least 2 consecutive seconds at idle speed.
5. If DTC is detected, go to [AT-110, "Diagnostic Procedure"](#) .

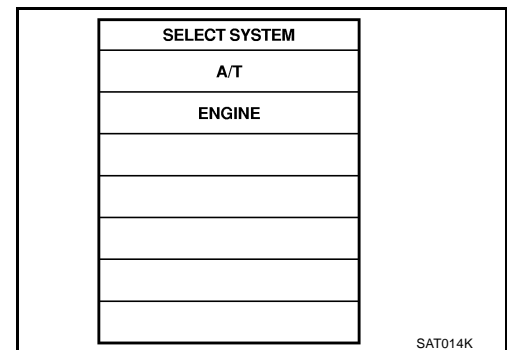

### Diagnostic Procedure

ACS003NZ

#### 1. CHECK DTC

#### Ⓜ With CONSULT-II

1. Turn ignition switch "ON". (Do not start engine.)
2. Select "SELF DIAG RESULTS" mode for "A/T" with CONSULT-II.
3. Touch "ERASE".
4. Turn ignition switch "OFF" and wait at least 10 seconds.
5. Perform DTC confirmation procedure, [AT-110, "DTC Confirmation Procedure"](#) .

Is the "TCM-ROM" displayed again?

- YES >> Replace the transmission assembly. Refer to [AT-192, "Removal and Installation"](#) .
- NO >> **INSPECTION END**

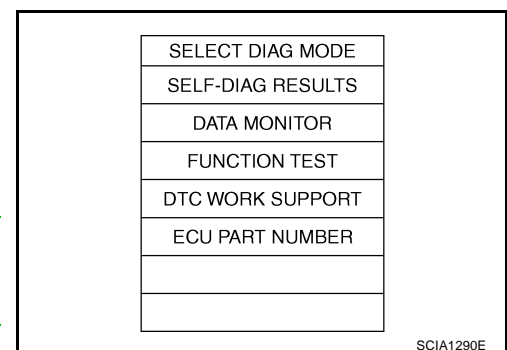

## DTC P1704 TRANSMISSION CONTROL MODULE (EEPROM)

PDF:31036

### Description

ACS00300

The TCM consists of a microcomputer and connectors for signal input and output and for power supply. The TCM controls the A/T.

### On Board Diagnosis Logic

ACS00301

- This is not an OBD-II self-diagnostic item.
- Diagnostic trouble code "TCM-EEPROM" with CONSULT-II is detected when TCM memory EEPROM is malfunctioning.

### Possible Cause

ACS00302

TCM.

### DTC Confirmation Procedure

ACS00303

#### NOTE:

If "DTC Confirmation Procedure" has been previously performed, always turn ignition switch "OFF" and wait at least 10 seconds before performing the next test.

After the repair, perform the following procedure to confirm the malfunction is eliminated.

#### WITH CONSULT-II

1. Turn ignition switch "ON". (Do not start engine.)
2. Select "DATA MONITOR" mode for "A/T" with CONSULT-II.
3. Start engine.
4. Run engine for at least 2 consecutive seconds at idle speed.
5. If DTC is detected, go to [AT-111, "Diagnostic Procedure"](#).

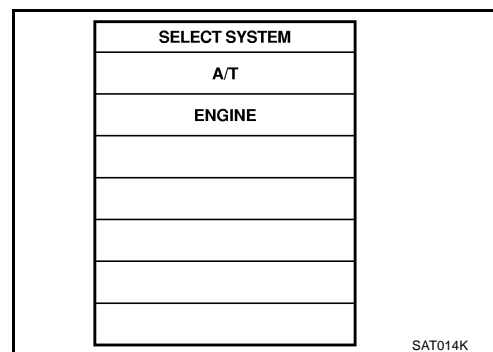

### Diagnostic Procedure

ACS004YB

#### 1. CHECK DTC

#### With CONSULT-II

1. Turn ignition switch "ON". (Do not start engine.)
2. Select "SELF DIAG RESULTS" mode for "A/T" with CONSULT-II.
3. Touch "ERASE".
4. Turn ignition switch "OFF" and wait at least 10 seconds.
5. Perform DTC confirmation procedure, [AT-111, "DTC Confirmation Procedure"](#).

Is the "TCM-ROM" displayed again?

- YES >> Replace the transmission assembly. Refer to [AT-192, "Removal and Installation"](#).
- NO >> **INSPECTION END**

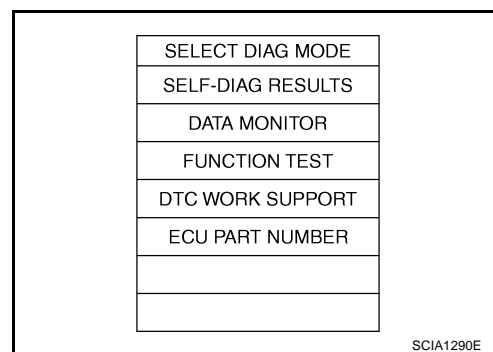

## DTC P1705 THROTTLE POSITION SENSOR

PFP:22620

### Description

ACS00305

Electric throttle control actuator consists of throttle control motor, accelerator pedal position sensor, throttle position sensor, etc. The actuator sends a signal to the ECM, and ECM sends signals to TCM with CAN communication.

### On Board Diagnosis Logic

ACS00306

- This is an OBD-II self-diagnostic item.
- Diagnostic trouble code "TP SEN/CIRC A/T" with CONSULT-II or P1705 without CONSULT-II is detected when TCM does not receive the proper accelerator pedal position signals (input by CAN communication) from ECM.

### Possible Cause

ACS00307

Harness or connectors  
 (The sensor circuit is open or shorted.)

### DTC Confirmation Procedure

ACS00308

#### NOTE:

If "DTC Confirmation Procedure" has been previously performed, always turn ignition switch "OFF" and wait at least 10 seconds before performing the next test.

After the repair, perform the following procedure to confirm the malfunction is eliminated.

#### WITH CONSULT-II

1. Turn ignition switch "ON". (Do not start engine.)
2. Select "DATA MONITOR" mode for "A/T" with CONSULT-II.
3. Start engine and let it idle for 1 second.
4. If DTC is detected, go to ["AT-112, "Diagnostic Procedure"](#) .

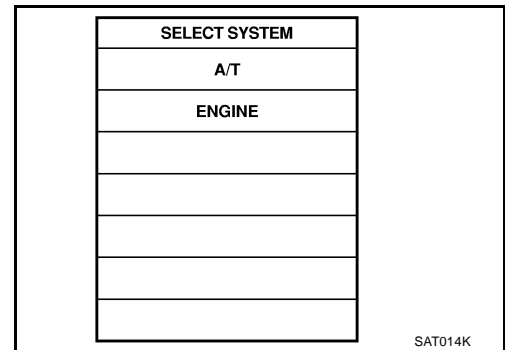

#### WITH GST

Follow the procedure "With CONSULT-II".

### Diagnostic Procedure

ACS00309

#### 1. CHECK CAN COMMUNICATION LINE

Perform the self-diagnosis. Refer to ["AT-76, "SELF-DIAGNOSTIC PROCEDURE \(WITH CONSULT-II\)"](#) , ["AT-87, "TCM SELF-DIAGNOSTIC PROCEDURE \(NO TOOLS\)"](#) .

Is a malfunction in the CAN communication indicated in the results.

- YES >> Check CAN communication line. Refer to ["AT-89, "DTC U1000 CAN COMMUNICATION LINE"](#) .  
 NO >> GO TO 2.



## 2. CHECK DTC WITH ECM

### With CONSULT-II

1. Turn ignition switch "ON". (Do not start engine.)
2. Select "SELF-DIAG RESULTS" mode for "ENGINE" with CONSULT-II. Refer to [EC-103, "CONSULT-II Function"](#) .

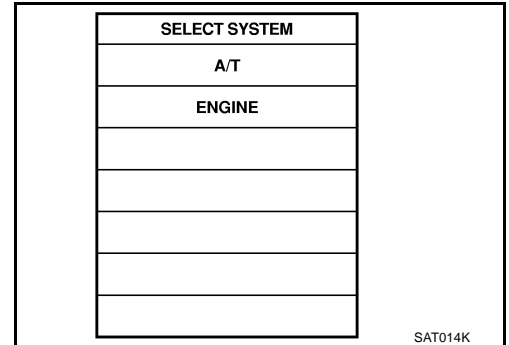

### With GST

Follow the procedure "With CONSULT-II".

#### OK or NG

- OK     >> GO TO 3.
- NG     >> Check the DTC detected item. Refer to [EC-103, "CONSULT-II Function"](#) .
- If CAN communication line is detected, go to [AT-89, "DTC U1000 CAN COMMUNICATION LINE"](#) .

## 3. CHECK DTC WITH TCM

### With CONSULT-II

1. Turn ignition switch "ON". (Do not start engine.)
2. Select "ECU INPUT SIGNALS" in "DATA MONITOR" mode for "A/T" with CONSULT-II.
3. Depress accelerator pedal and read out the value of "ACCLE POS" and "THROTTLE POSI".  
Check engine speed changes according to throttle position.
4. Select "SELF-DIAG RESULTS" mode for "ENGINE" with CONSULT-II. Refer to [EC-107, "SELF-DIAG RESULTS MODE"](#) .

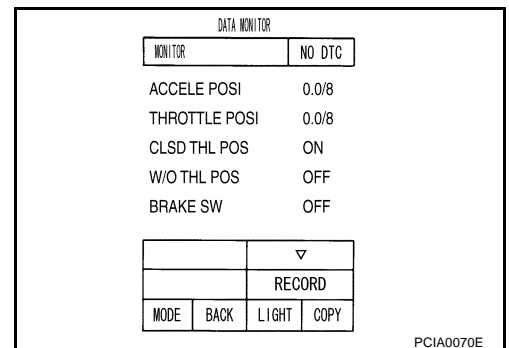

### With GST

Follow the procedure "With CONSULT-II".

#### OK or NG

- OK     >> GO TO 4.
- NG     >> Repair or replace damaged parts.

## 4. CHECK DTC

Perform DTC Confirmation Procedure.

- Refer to [AT-112, "DTC Confirmation Procedure"](#) .

#### OK or NG

- OK     >> **INSPECTION END**
- NG     >> Replace the transmission assembly. Refer to [AT-192, "Removal and Installation"](#) .

## DTC P1710 A/T FLUID TEMPERATURE SENSOR CIRCUIT

PFP:31940

### Description

ACS0030A

The A/T fluid temperature sensor detects the A/T fluid temperature and sends a signal to the TCM.

### CONSULT-II Reference Value

ACS0030B

Item name	Condition °C (°F)	Display value (Approx.) V
ATF TEMP SE 1	0 (32) - 20 (68) - 80 (176)	3.2 - 2.5 - 0.8
ATF TEMP SE 2		3.2 - 2.4 - 0.65

### On Board Diagnosis Logic

ACS0030C

- This is an OBD-II self-diagnostic item.
- Diagnostic trouble code “ATF TEMP SEN/CIRC” with CONSULT-II or P1710 (A/T), P0710 (ENGINE) without CONSULT-II is detected when TCM receives an excessively low or high voltage from the sensor.

### Possible Cause

ACS0030D

- Harness or connectors  
(The sensor circuit is open or shorted.)
- A/T fluid temperature sensors 1, 2

### DTC Confirmation Procedure

ACS0030E

#### CAUTION:

Always drive vehicle at a safe speed.

#### NOTE:

If “DTC Confirmation Procedure” has been previously performed, always turn ignition switch “OFF” and wait at least 10 seconds before performing the next test.

After the repair, perform the following procedure to confirm the malfunction is eliminated.

#### WITH CONSULT-II

1. Turn ignition switch “ON”. (Do not start engine.)
2. Select “DATA MONITOR” mode for “ENGINE” with CONSULT-II.
3. Start engine and maintain the following conditions for at least 10 minutes (Total). (It is not necessary to maintain continuously.)  
**VHCL SPEED SE: 10 km/h (6 MPH) or more**  
**THRTL POS SEN: More than 1.0/8**  
**Selector lever: “D” position**
4. If DTC is detected, go to [AT-115, "Diagnostic Procedure"](#) .

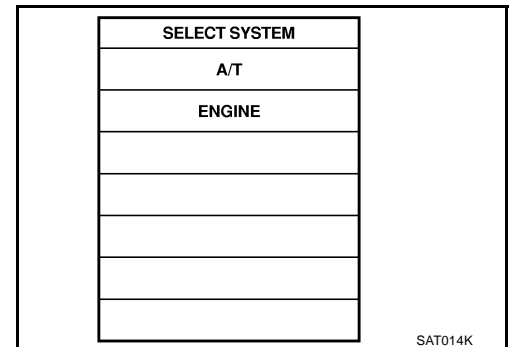

#### WITH GST

Follow the procedure “With CONSULT-II”.

## Diagnostic Procedure

ACS0030F

### 1. CHECK FLUID TEMPERATURE SENSOR (WITH CONSULT-II)

#### With CONSULT-II

1. Start engine.
2. Select "ECU INPUT SIGNALS" in "DATA MONITOR" mode for "A/T" with CONSULT-II.
3. Read out the value of "ATF TEMP SE 1" or "ATF TEMP SE 2".

Item name	Condition °C (°F)	Display value (Approx.) V
ATF TEMP SE 1	0 (32) - 20 (68) - 80 (176)	3.2 - 2.5 - 0.8
ATF TEMP SE 2		3.2 - 2.4 - 0.65

#### OK or NG

- OK >> GO TO 4.  
 NG >> GO TO 2.

DATA MONITOR	
MONITOR	NO DTC
OUTPUT REV	0 rpm
ATF TEMP SE 1	1.84 v
ATF TEMP SE 2	1.72 v
BATTERY BOLT	11.5 v
ATF PRES SW 1	OFF

△	▽
RECORD	
MODE	COPY

PCIA0039E

### 2. CHECK TCM

Perform TCM input/output signal inspection. Refer to [AT-74, "TCM Input/Output Signal Reference Values"](#) .

#### OK or NG

- OK >> GO TO 4.  
 NG >> GO TO 3.

### 3. DETECT MALFUNCTIONING ITEM

Check the following items:

- Power supply and ground circuit for TCM.
- The A/T assembly harness connector pin terminals for damage or loose connection with harness connector.

#### OK or NG

- OK >> Replace the transmission assembly. Refer to [AT-192, "Removal and Installation"](#) .  
 NG >> Repair or replace damaged parts.

### 4. CHECK DTC

Perform DTC Confirmation Procedure.

- Refer to [AT-114, "DTC Confirmation Procedure"](#) .

#### OK or NG

- OK >> **INSPECTION END**  
 NG >> GO TO 2.

## DTC P1716 TURBINE REVOLUTION SENSOR

PFP:31935

### Description

ACS0030G

The turbine revolution sensor detects input shaft rpm (revolutions per minute). It is located on the input side of the automatic transmission. Monitors revolution of sensor 1 and sensor 2 for non-standard conditions.

### CONSULT-II Reference Value

ACS0030H

Item name	Condition	Display value (rpm)
TURBINE REV	During driving (lock-up ON)	Approximately matches the engine speed.

### On Board Diagnosis Logic

ACS0030I

- This is an OBD-II self-diagnostic item.
- Diagnostic trouble code “TURBINE REV S/CIRC” with CONSULT-II or P1716 without CONSULT-II is detected under the following conditions.
  - When TCM does not receive the proper voltage signal from the sensor.
  - When TCM detects an irregularity only at position of 4th gear for turbine revolution sensor 2.

### Possible Cause

ACS0030J

- Harness or connectors  
(The sensor circuit is open or shorted.)
- Turbine revolution sensor 1, 2

### DTC Confirmation Procedure

ACS0030K

#### CAUTION:

Always drive vehicle at a safe speed.

#### NOTE:

If “DTC Confirmation Procedure” has been previously performed, always turn ignition switch “OFF” and wait at least 10 seconds before performing the next test.

After the repair, perform the following procedure to confirm the malfunction is eliminated.

#### WITH CONSULT-II

1. Turn ignition switch “ON”. (Do not start engine.)
2. Select “DATA MONITOR” mode for “A/T” with CONSULT-II.
3. Start engine and maintain the following conditions for at least 5 consecutive seconds.

**VHCL SPEED SE: 40 km/h (25 MPH) or more**

**ENGINE SPEED: 1,500 rpm or more**

**ACCELE POSI: 0.5/8 or more**

**Selector lever: “D” position**

**Gear position (Turbine revolution sensor 1): 4th or 5th position**

**Gear position (Turbine revolution sensor 2): All position**

**Driving location: Driving the vehicle uphill (increased engine load) will help maintain the driving conditions required for this test.**

4. If DTC is detected, go to [AT-117, "Diagnostic Procedure"](#) .

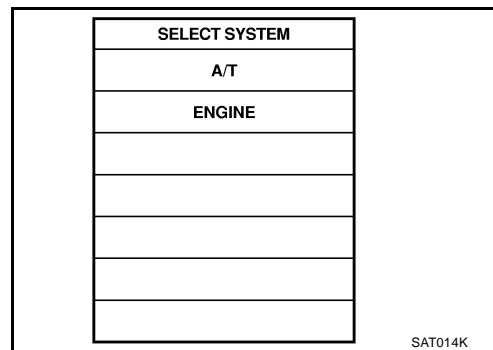

#### WITH GST

Follow the procedure “With CONSULT-II”.

## Diagnostic Procedure

### 1. CHECK INPUT SIGNALS

#### With CONSULT-II

1. Start engine.
2. Select "ECU INPUT SIGNALS" in "DATA MONITOR" mode for "A/T" with CONSULT-II.
3. Vehicle start and read out the value of "TURBINE REV".

DATA MONITOR			
MONITOR	NO DTC		
W/O THL POS	OFF		
BRAKE SW	OFF		
ENGINE SPEED	0 rpm		
TURBINE REV	0 rpm		
OUTPUT REV	0 rpm		
▼			
RECORD			
MODE	BACK	LIGHT	COPY

PCIA0041E

Item name	Condition	Display value (rpm)
TURBINE REV	During driving (lock-up ON)	Approximately matches the engine speed.

#### OK or NG

- OK     >> GO TO 4.  
 NG     >> GO TO 2.

### 2. CHECK TCM

Perform TCM input/output signal inspection. Refer to [AT-74, "TCM Input/Output Signal Reference Values"](#) .

#### OK or NG

- OK     >> GO TO 4.  
 NG     >> GO TO 3.

### 3. DETECT MALFUNCTIONING ITEM

Check the following items:

- Power supply and ground circuit for TCM.
- The A/T assembly harness connector pin terminals for damage or loose connection with harness connector.

#### OK or NG

- OK     >> Replace the transmission assembly. Refer to [AT-192, "Removal and Installation"](#) .  
 NG     >> Repair or replace damaged parts.

### 4. CHECK DTC

Perform DTC Confirmation Procedure.

- Refer to [AT-116, "DTC Confirmation Procedure"](#) .

#### OK or NG

- OK     >> **INSPECTION END**  
 NG     >> GO TO 2.

## DTC P1721 VEHICLE SPEED SENSOR MTR

PFP:24814

### Description

ACS0030M

The vehicle speed sensor-MTR signal is transmitted from combination meter to TCM by CAN communication line. The signal functions as an auxiliary device to the revolution sensor when it is malfunctioning. The TCM will then use the vehicle speed sensor-MTR signal.

### CONSULT-II Reference Value

ACS0030N

Item name	Condition	Display value (Approx.) (km/h)
VHCL/S SE-MTR	During driving	Approximately matches the speedometer reading.

### On Board Diagnosis Logic

ACS0030O

- This is not an OBD-II self-diagnostic item.
- Diagnostic trouble code “VHE SPD SE/CIR-MTR” with CONSULT-II is detected when TCM does not receive the proper vehicle speed sensor MTR signal (input by CAN communication) from combination meter.

### Possible Cause

ACS0030P

Harness or connectors  
 (The sensor circuit is open or shorted.)

### DTC Confirmation Procedure

ACS0030Q

**CAUTION:**

**Always drive vehicle at a safe speed.**

**NOTE:**

**If “DTC Confirmation Procedure” has been previously performed, always turn ignition switch “OFF” and wait at least 10 seconds before performing the next test.**

After the repair, perform the following procedure to confirm the malfunction is eliminated.

Ⓟ **WITH CONSULT-II**

1. Turn ignition switch “ON”. (Do not start engine.)
2. Select “DATA MONITOR” mode for “A/T” with CONSULT-II.
3. Start engine and maintain the following conditions for at least 5 consecutive seconds.  
**ACCELE POSI: 1/8 or less**  
**VHCL SPEED SE: 30 km/h (17 MPH) or more**
4. If DTC is detected, go to [AT-119, "Diagnostic Procedure"](#) .

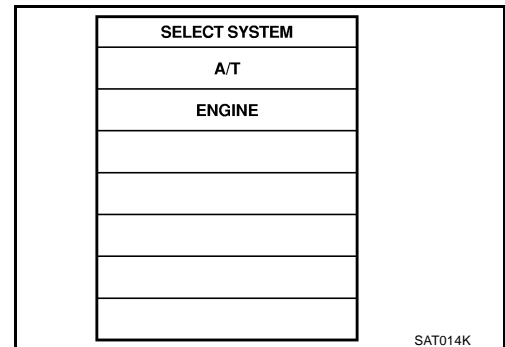

SAT014K

## Diagnostic Procedure

ACS0030R

### 1. CHECK CAN COMMUNICATION LINE

Perform the self-diagnosis. Refer [AT-76, "SELF-DIAGNOSTIC PROCEDURE \(WITH CONSULT-II\)"](#) , [AT-87, "TCM SELF-DIAGNOSTIC PROCEDURE \(NO TOOLS\)"](#) .

Is a malfunction in the CAN communication indicated in the results?

YES >> Check CAN communication line. Refer to [AT-89, "DTC U1000 CAN COMMUNICATION LINE"](#) .

NO >> GO TO 2.

### 2. CHECK INPUT SIGNALS

#### With CONSULT-II

1. Start engine.
2. Select "ECU INPUT SIGNALS" in "DATA MONITOR" mode for "A/T" with CONSULT-II.
3. Drive vehicle and read out the value of "VHCL/S SE-MTR".

Item name	Condition	Display value (Approx.) (km/h)
VHCL/S SE-MTR	During driving	Approximately matches the speedometer reading.

DATA MONITOR			
MONITOR		NO DTC	
VHCL/S SE-A/T		0km/h	
VHCL/S SE-MTR		0km/h	
ACCELE POSI		0.0/8	
THROTTLE POS		0.0/8	
CLSD THL POS		ON	
W/O THL POS		OFF	
		▼	
RECORD			
MODE	BACK	LIGHT	COPY

SCIA2148E

#### Without CONSULT-II

1. Start engine.
2. Drive vehicle.
3. Perform self-diagnosis. Refer to [EC-103, "CONSULT-II Function"](#) .

OK or NG

OK >> GO TO 3.

NG >> Repair or replace damaged parts.

### 3. CHECK TCM

Perform TCM input/output signal inspection. Refer to [AT-74, "TCM Input/Output Signal Reference Values"](#) .

OK or NG

OK >> GO TO 5.

NG >> GO TO 4.

### 4. DETECT MALFUNCTIONING ITEM

Check the following items:

- Power supply and ground circuit for TCM.
- The A/T assembly harness connector pin terminals for damage or loose connection with harness connector.

OK or NG

OK >> Replace the transmission assembly. Refer to [AT-192, "Removal and Installation"](#) .

NG >> Repair or replace damaged parts.

### 5. CHECK DTC

Perform DTC Confirmation Procedure.

- Refer to [AT-118, "DTC Confirmation Procedure"](#) .

OK or NG

OK >> **INSPECTION END**

NG >> GO TO 3.

## DTC P1730 A/T INTERLOCK

PFP:00000

### Description

ACS0030S

- Fail-safe function to detect interlock conditions.

### On Board Diagnosis Logic

ACS0030T

- This is an OBD-II self-diagnostic item.
- Diagnostic trouble code “A/T INTERLOCK” with CONSULT-II or P1730 without CONSULT-II is detected when TCM does not receive the proper voltage signal from the sensor and switch.
- TCM monitors and compares gear position and conditions of each ATF pressure switch when gear is steady.

### Possible Cause

ACS0030U

- Harness or connectors  
(The solenoid and switch circuit is open or shorted.)
- Input, direct, high and low reverse clutch, front, low coast brake solenoid valve
- ATF pressure switch 1, 2, 3, 5 and 6

### DTC Confirmation Procedure

ACS0030V

#### NOTE:

If “DTC Confirmation Procedure” has been previously performed, always turn ignition switch “OFF” and wait at least 10 seconds before performing the next test.

After the repair, perform the following procedure to confirm the malfunction is eliminated.

#### WITH CONSULT-II

1. Turn ignition switch “ON”. (Do not start engine.)
2. Select “DATA MONITOR” mode for “A/T” with CONSULT-II.
3. Start engine.
4. Drive vehicle and maintain the following conditions for at least 2 consecutive seconds.  
**Selector lever: “D” position**
5. If DTC is detected, go to [AT-122, "Diagnostic Procedure"](#) .

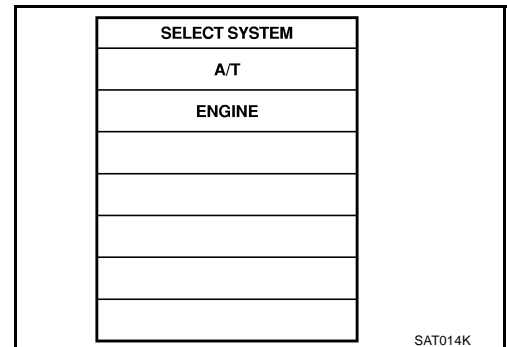

#### WITH GST

Follow the procedure “With CONSULT-II”.

### Judgement of A/T Interlock

ACS0030W

When A/T Interlock is judged to be malfunctioning, the vehicle should be fixed in 2nd, 4th, or 5th gear, and should be set in a condition in which it can travel.

When one of the following fastening patterns is detected, the fail-safe function in correspondence with the individual pattern should be performed.



**A/T INTERLOCK COUPLING PATTERN TABLE**

●: NG, X: OK

Gear position		ATF pressure switch output					Fail-safe function	Clutch pressure output pattern after fail-safe function					
		SW3 (I/C)	SW6 (H&LR /C)	SW5 (D/C)	SW1 (FR/B)	SW2 (LC/B)		I/C	H&LR/C	D/C	FR/B	LC/B	L/U
A/T interlock coupling pattern	1st	●	X	-	X	X	Held in 4th gear	ON	ON	ON	OFF	OFF	OFF
		-	X	●	-	X	Held in 4th gear	ON	ON	ON	OFF	OFF	OFF
	2nd	-	●	X	-	X	Held in 4th gear	ON	ON	ON	OFF	OFF	OFF
		●	-	X	X	-	Held in 4th gear	ON	ON	ON	OFF	OFF	OFF
	3rd	-	X	X	-	●	Held in 2nd gear	OFF	OFF	ON	OFF	OFF	OFF
		●	-	X	X	-	Held in 4th gear	ON	ON	ON	OFF	OFF	OFF
	4th	-	X	X	-	●	Held in 2nd gear	OFF	OFF	ON	OFF	OFF	OFF
		X	-	X	●	-	Held in 5th gear	ON	ON	OFF	ON	OFF	OFF
	5th	X	X	-	X	●	Held in 2nd gear	OFF	OFF	ON	OFF	OFF	OFF
		X	-	●	X	-	Held in 4th gear	ON	ON	ON	OFF	OFF	OFF

A  
B  
AT  
D  
E  
F  
G  
H  
I  
J  
K  
L  
M

## Diagnostic Procedure

ACS0030X

### 1. SELF-DIAGNOSIS

#### ④ With CONSULT-II

1. Start engine.
2. Select "SELF-DIAG RESULTS" mode for "A/T" with CONSULT-II.
3. Drive vehicle.

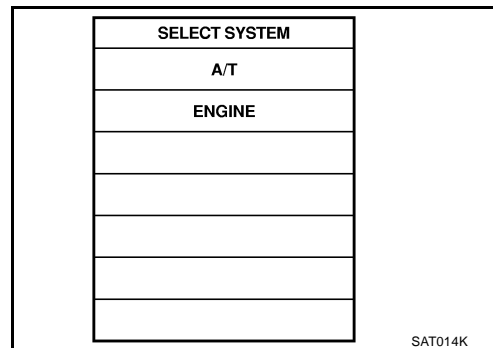

#### ⊗ Without CONSULT-II

1. Drive vehicle.
2. Stop vehicle and turn ignition switch OFF.
3. Turn ignition switch "ON". (Do not start engine.)
4. Perform self-diagnosis. Refer to [AT-87, "TCM SELF-DIAGNOSTIC PROCEDURE \(NO TOOLS\)"](#) .

#### OK or NG

OK >> GO TO 2.

- NG >> ● Check pressure switch, Refer to [AT-149, "DTC P1841 ATF PRESSURE SWITCH 1"](#) , [AT-151, "DTC P1843 ATF PRESSURE SWITCH 3"](#) , [AT-153, "DTC P1845 ATF PRESSURE SWITCH 5"](#) , [AT-155, "DTC P1846 ATF PRESSURE SWITCH 6"](#) .
- Check each solenoid valves, Refer to [AT-125, "DTC P1752 INPUT CLUTCH SOLENOID VALVE"](#) , [AT-129, "DTC P1757 FRONT BRAKE SOLENOID VALVE"](#) , [AT-133, "DTC P1762 DIRECT CLUTCH SOLENOID VALVE"](#) , [AT-137, "DTC P1767 HIGH AND LOW REVERSE CLUTCH SOLENOID VALVE"](#) , [AT-141, "DTC P1772 LOW COAST BRAKE SOLENOID VALVE"](#) .

### 2. CHECK TCM

Perform TCM input/output signal inspection. Refer to [AT-74, "TCM Input/Output Signal Reference Values"](#) .

#### OK or NG

OK >> GO TO 4.

NG >> GO TO 3.

### 3. DETECT MALFUNCTIONING ITEM

Check the following items:

- Power supply and ground circuit for TCM.
- The A/T assembly harness connector pin terminals for damage or loose connection with harness connector.

#### OK or NG

OK >> Replace the transmission assembly. Refer to [AT-192, "Removal and Installation"](#) .

NG >> Repair or replace damaged parts.

### 4. CHECK DTC

Perform DTC Confirmation Procedure.

- Refer to [AT-120, "DTC Confirmation Procedure"](#) .

#### OK or NG

OK >> **INSPECTION END**

NG >> GO TO 2.

## DTC P1731 A/T 1ST ENGINE BRAKING

PFP:00000

### Description

ACS0030Y

Fail-safe function to prevent sudden decrease in speed by engine brake other than at M1 position.

### CONSULT-II Reference Value

ACS0030Z

Item name	Condition	Display value (ON-OFF display)
ON OFF SOL	Low coast brake operates. Refer to <a href="#">AT-17</a>	ON
	Other conditions	OFF

Item name	Condition	Display value (ON-OFF display)
ATF PRES SW 2	Low coast brake operates. Refer to <a href="#">AT-17</a>	ON
	Other conditions	OFF

### On Board Diagnosis Logic

ACS003P0

- This is not an OBD-II self-diagnostic item.
- Diagnostic trouble code “A/T 1ST E/BRAKING” with CONSULT-II or 13th judgement flicker without CONSULT-II is detected under the following conditions.
  - When TCM does not receive the proper voltage signal from the sensor.
  - When TCM monitors each ATF pressure switch and solenoid monitor value, and detects as irregular when engine brake of 1st gear acts other than at M1 position.

### Possible Cause

ACS003P1

- Harness or connectors  
(The sensor circuit is open or shorted.)
- Low coast brake solenoid valve
- ATF pressure switch 2

### DTC Confirmation Procedure

ACS003P2

#### NOTE:

If “DTC Confirmation Procedure” has been previously preformed, always turn ignition switch “OFF” and wait at least 10 seconds before performing the next test.

After the repair, perform the following procedure to confirm the malfunction is eliminated.

#### Ⓟ WITH CONSULT-II

1. Turn ignition switch “ON”. (Do not start engine.)
2. Select “DATA MONITOR” mode for “A/T” with CONSULT-II.
3. Start engine.
4. Drive vehicle and maintain the following conditions for at least 2 consecutive seconds.  
**ENGINE SPEED: 1,200 rpm**  
**Selector lever: “M” position**  
**Gear position: 1st gear**
5. If DTC is detected, go to [AT-124, "Diagnostic Procedure"](#) .

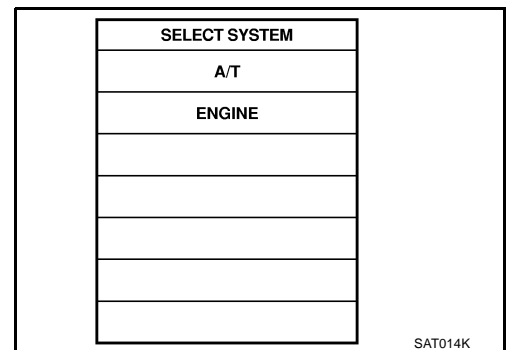

## Diagnostic Procedure

ACS003P3

### 1. CHECK INPUT SIGNALS

**With CONSULT-II**

1. Start the engine.
2. Select "ECU INPUT SIGNALS" or "MAIN SIGNALS" in "DATA MONITOR" mode for "A/T" with CONSULT-II.
3. Drive vehicle in the "M" position (1st gear), and confirm the ON/OFF actuation of the "ATF PRES SW 2".

DATA MONITOR			
MONITOR		NO. DTC	
ATF PRES SW 1		OFF	
ATF PRES SW 2		OFF	
ATF PRES SW 3		OFF	
ATF PRES SW 5		OFF	
ATF PRES SW 6		OFF	

△		▽	
RECORD			
MODE	BACK	LIGHT	COPY

PCIA0067E

**OK or NG**

- OK >> GO TO 4.
- NG >> GO TO 2.

### 2. CHECK TCM

Perform TCM input/output signal inspection. Refer to [AT-74, "TCM Input/Output Signal Reference Values"](#) .

**OK or NG**

- OK >> GO TO 4.
- NG >> GO TO 3.

### 3. DETECT MALFUNCTIONING ITEM

Check the following items:

- Power supply and ground circuit for TCM.
- The A/T assembly harness connector pin terminals for damage or loose connection with harness connector.

**OK or NG**

- OK >> Replace the transmission assembly. Refer to [AT-192, "Removal and Installation"](#) .
- NG >> Repair or replace damaged parts.

### 4. CHECK DTC

Perform DTC Confirmation Procedure.

- Refer to [AT-123, "DTC Confirmation Procedure"](#) .

**OK or NG**

- OK >> **INSPECTION END**
- NG >> GO TO 2.

## DTC P1752 INPUT CLUTCH SOLENOID VALVE

PF3:31940

### Description

ACS003P4

Input clutch solenoid valve is controlled by the TCM in response to signals sent from the PNP switch, vehicle speed sensor and accelerator pedal position sensor (throttle position sensor). Gears will then be shifted to the optimum position.

### CONSULT-II Reference Value

ACS003P5

Item name	Condition	Display value (Approx) (A)
I/C SOLENOID	Input clutch operates. Refer to <a href="#">AT-17</a>	0.6 - 0.8
	Other conditions	0 - 0.05

### On Board Diagnosis Logic

ACS003P6

- This is an OBD-II self-diagnostic item.
- Diagnostic trouble code "I/C SOLENOID/CIRC" with CONSULT-II or P1752 without CONSULT-II is detected under the following conditions.
  - When TCM detects an improper voltage drop when it tries to operate the solenoid valve.
  - When TCM detects as irregular by comparing target value with monitor value.

### Possible Cause

ACS003P7

- Harness or connectors  
(The solenoid circuit is open or shorted.)
- Input clutch solenoid valve

### DTC Confirmation Procedure

ACS003P8

#### CAUTION:

Always drive vehicle at a safe speed.

#### NOTE:

If "DTC Confirmation Procedure" has been previously performed, always turn ignition switch "OFF" and wait at least 10 seconds before performing the next test.

After the repair, perform the following procedure to confirm the malfunction is eliminated.

#### ⓑ WITH CONSULT-II

1. Turn ignition switch "ON". (Do not start engine.)
2. Select "DATA MONITOR" mode for "A/T" with CONSULT-II.
3. Start engine.
4. Drive vehicle and maintain the following conditions for at least 5 consecutive seconds.
  - ACCELE POSI: 1.5/8 - 2.0/8**
  - Selector lever: "D" position**
  - Gear position: 3rd ⇒ 4th Gear (I/C ON/OFF)**
  - Driving location: Driving the vehicle uphill (increased engine load) will help maintain the driving conditions required for this test.**
5. If DTC is detected go to "[AT-126, "Diagnostic Procedure"](#)".

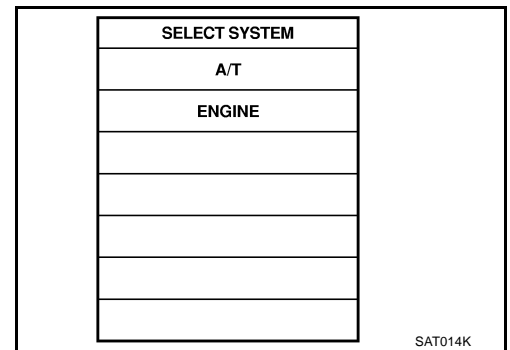

#### Ⓒ WITH GST

Follow the procedure "With CONSULT-II".

---

## Diagnostic Procedure

ACS003P9

### 1. CHECK TCM

---

Perform TCM input/output signal inspection. Refer to [AT-74, "TCM Input/Output Signal Reference Values"](#) .

OK or NG

- OK >> GO TO 3.
- NG >> GO TO 2.

### 2. DETECT MALFUNCTIONING ITEM

---

Check the following items:

- Power supply and ground circuit for TCM.
- The A/T assembly harness connector pin terminals for damage or loose connection with harness connector.

OK or NG

- OK >> Replace the transmission assembly. Refer to [AT-192, "Removal and Installation"](#) .
- NG >> Repair or replace damaged parts.

### 3. CHECK DTC

---

Perform DTC Confirmation Procedure.

- Refer to [AT-125, "DTC Confirmation Procedure"](#) .

OK or NG

- OK >> **INSPECTION END**
- NG >> GO TO 1.

## DTC P1754 INPUT CLUTCH SOLENOID VALVE FUNCTION

PF3:31940

### Description

ACS003PA

- Input clutch solenoid valve is controlled by the TCM in response to signals sent from the PNP switch, vehicle speed sensor and accelerator pedal position sensor (throttle position sensor). Gears will then be shifted to the optimum position.
- This is not only caused by electrical malfunction (circuits open or shorted) but also by mechanical malfunction such as control valve sticking, improper solenoid valve operation.

### CONSULT-II Reference Value

ACS003PB

Item name	Condition	Display value (Approx) (A)
I/C SOLENOID	Input clutch operates. Refer to <a href="#">AT-17</a>	0.6 - 0.8
	Other conditions	0 - 0.05

Item name	Condition	Display value (ON-OFF display)
ATF PRES SW 3	Input clutch operates. Refer to <a href="#">AT-17</a>	ON
	Other conditions	OFF

### On Board Diagnosis Logic

ACS003PC

- This is an OBD-II self-diagnostic item.
- Diagnostic trouble code "I/C SOLENOID FNCTN" with CONSULT-II or P1754 without CONSULT-II is detected under the following conditions.
  - When TCM detects that actual gear ratio is irregular, and relation between gear position and condition of pressure switch 3 is irregular during depressing accelerator pedal. (Other than during shift change)
  - When TCM detects that relation between gear position and condition of ATF pressure switch 3 is irregular during releasing accelerator pedal. (Other than during shift change)

### Possible Cause

ACS003PD

- Harness or connectors  
(The solenoid and switch circuits are open or shorted.)
- Input clutch solenoid valve
- ATF pressure switch 3

### DTC Confirmation Procedure

ACS003PE

#### CAUTION:

Always drive vehicle at a safe speed.

#### NOTE:

If "DTC Confirmation Procedure" has been previously performed, always turn ignition switch "OFF" and wait at least 10 seconds before performing the next test.

After the repair, perform the following procedure to confirm the malfunction is eliminated.

#### WITH CONSULT-II

1. Start engine.
2. Accelerate vehicle to maintain the following conditions.  
**ACCELE POSI: 1.5/8 - 2.0/8**  
**Selector lever: "D" position**  
**Gear position: 3rd ⇒ 4th Gear (I/C ON/OFF)**  
**Driving location: Driving the vehicle uphill (increased engine load) will help maintain the driving conditions required for this test.**
3. Perform step "2" again.
4. Turn ignition switch "OFF", then perform step "1" to "3" again.
5. Check "SELF-DIAG RESULTS" mode for "A/T" with CONSULT-II. If DTC (P1754) is detected, refer to [AT-128, "Diagnostic Procedure"](#).  
 If DTC (P1752) is detected, go to [AT-126, "Diagnostic Procedure"](#).  
 If DTC (P1843) is detected, go to [AT-152, "Diagnostic Procedure"](#).

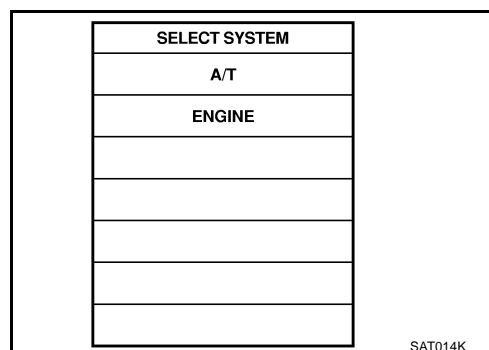

**WITH GST**

Follow the procedure "With CONSULT-II".

## Diagnostic Procedure

ACS003PF

### 1. CHECK INPUT SIGNALS

**With CONSULT-II**

1. Start engine.
2. Select "ECU INPUT SIGNALS" or "MAIN SIGNALS" in "DATA MONITOR" mode for "A/T" with CONSULT-II.
3. Drive vehicle in the "D" position (3rd ⇒ 4th gear), and confirm the ON/OFF actuation of the "ATF PRES SW 3".

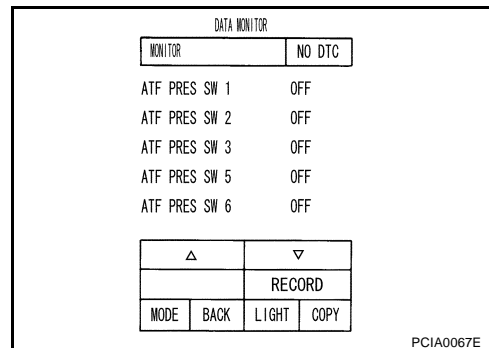

Item name	Condition	Display value (ON-OFF display)
ATF PRES SW 3	Input clutch operates. Refer to <a href="#">AT-17</a>	ON
	Other conditions	OFF

**With GST**

Follow the procedure "With CONSULT-II".

OK or NG

- OK >> GO TO 4.
- NG >> GO TO 2.

### 2. CHECK TCM

Perform TCM input/output signal inspection. Refer to [AT-74, "TCM Input/Output Signal Reference Values"](#) .

OK or NG

- OK >> GO TO 4.
- NG >> GO TO 3.

### 3. DETECT MALFUNCTIONING ITEM

Check the following items:

- Power supply and ground circuit for TCM.
- The A/T assembly harness connector pin terminals for damage or loose connection with harness connector.

OK or NG

- OK >> Replace the transmission assembly. Refer to [AT-192, "Removal and Installation"](#) .
- NG >> Repair or replace damaged parts.

### 4. CHECK DTC

Perform DTC Confirmation Procedure.

- Refer to [AT-127, "DTC Confirmation Procedure"](#) .

OK or NG

- OK >> **INSPECTION END**
- NG >> GO TO 2.



## DTC P1757 FRONT BRAKE SOLENOID VALVE

PFP:31940

### Description

ACS003PG

Front brake solenoid valve is controlled by the TCM in response to signals sent from the PNP switch, vehicle speed sensor and accelerator pedal position sensor (throttle position sensor). Gears will then be shifted to the optimum position.

### CONSULT-II Reference Value

ACS003PH

Item name	Condition	Display value (Approx) (A)
FR/B SOLENOID	Front brake operates. Refer to <a href="#">AT-17</a>	0.6 - 0.8
	Other conditions	0 - 0.05

### On Board Diagnosis Logic

ACS003PI

- This is an OBD-II self-diagnostic item.
- Diagnostic trouble code “FR/B SOLENOID/CIRC” with CONSULT-II or P1757 without CONSULT-II is detected under the following conditions.
  - When TCM detects an improper voltage drop when it tries to operate the solenoid valve.
  - When TCM detects as irregular by comparing target value with monitor value.

### Possible Cause

ACS003PJ

- Harness or connectors  
(The solenoid circuit is open or shorted.)
- Front brake solenoid valve

### DTC Confirmation Procedure

ACS003PK

#### **CAUTION:**

Always drive vehicle at a safe speed.

#### **NOTE:**

If “DTC Confirmation Procedure” has been previously performed, always turn ignition switch “OFF” and wait at least 10 seconds before performing the next test.

After the repair, perform the following procedure to confirm the malfunction is eliminated.

#### **ⓑ WITH CONSULT-II**

1. Turn ignition switch “ON”. (Do not start engine.)
2. Select “DATA MONITOR” mode for “A/T” with CONSULT-II.
3. Start engine.
4. Drive vehicle and maintain the following conditions for at least 5 consecutive seconds.  
**ACCELE POSI: 1.5/8 - 2.0/8**  
**Selector lever: “D” position**  
**Gear position: 3rd ⇒ 4th Gear (FR/B ON/OFF)**  
**Driving location: Driving the vehicle uphill (increased engine load) will help maintain the driving conditions required for this test.**
5. If DTC is detected go to [AT-130, "Diagnostic Procedure"](#) .

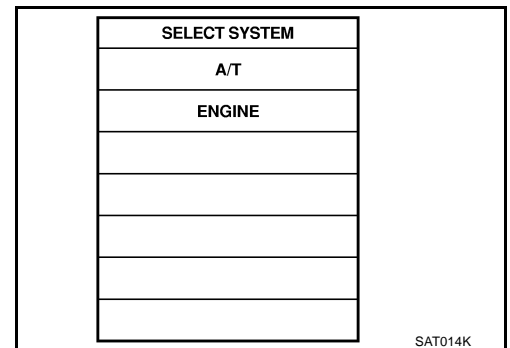

#### **Ⓒ WITH GST**

Follow the procedure “With CONSULT-II”.

---

## Diagnostic Procedure

ACS003PL

### 1. CHECK TCM

---

Perform TCM input/output signal inspection. Refer to [AT-74, "TCM Input/Output Signal Reference Values"](#) .

OK or NG

- OK >> GO TO 3.
- NG >> GO TO 2.

### 2. DETECT MALFUNCTIONING ITEM

---

Check the following items:

- Power supply and ground circuit for TCM.
- The A/T assembly harness connector pin terminals for damage or loose connection with harness connector.

OK or NG

- OK >> Replace the transmission assembly. Refer to [AT-192, "Removal and Installation"](#) .
- NG >> Repair or replace damaged parts.

### 3. CHECK DTC

---

Perform DTC Confirmation Procedure.

- Refer to [AT-129, "DTC Confirmation Procedure"](#) .

OK or NG

- OK >> **INSPECTION END**
- NG >> GO TO 1.

## DTC P1759 FRONT BRAKE SOLENOID VALVE FUNCTION

PF3:31940

### Description

ACS003PM

- Front brake solenoid valve is controlled by the TCM in response to signals sent from the PNP switch, vehicle speed sensor and accelerator pedal position sensor (throttle position sensor). Gears will then be shifted to the optimum position.
- This is not only caused by electrical malfunction (circuits open or shorted) but also by mechanical malfunction such as control valve sticking, improper solenoid valve operation.

### CONSULT-II Reference Value

ACS003PN

Item name	Condition	Display value (Approx) (A)
FR/B SOLENOID	Front brake operates. Refer to <a href="#">AT-17</a>	0.6 - 0.8
	Other conditions	0 - 0.05

Item name	Condition	Display value (ON-OFF display)
ATF PRES SW 1	Front brake operates. Refer to <a href="#">AT-17</a>	ON
	Other conditions	OFF

### On Board Diagnosis Logic

ACS003PO

- This is an OBD-II self-diagnostic item.
- Diagnostic trouble code "FR/B SOLENOID FNCT" with CONSULT-II or P1759 without CONSULT-II is detected under the following conditions.
  - When TCM detects that actual gear ratio is irregular, and relation between gear position and condition of ATF pressure switch 1 is irregular during depressing accelerator pedal. (Other than during shift change)
  - When TCM detects that relation between gear position and condition of ATF pressure switch 1 is irregular during releasing accelerator pedal. (Other than during shift change)

### Possible Cause

ACS003PP

- Harness or connectors  
(The solenoid and switch circuits are open or shorted.)
- Front brake solenoid valve
- ATF pressure switch 1

### DTC Confirmation Procedure

ACS003PQ

#### CAUTION:

Always drive vehicle at a safe speed.

#### NOTE:

If "DTC Confirmation Procedure" has been previously performed, always turn ignition switch "OFF" and wait at least 10 seconds before performing the next test.

After the repair, perform the following procedure to confirm the malfunction is eliminated.

#### WITH CONSULT-II

1. Start engine.
2. Accelerate vehicle to maintain the following conditions.  
**ACCELE POSI: 1.5/8 - 2.0/8**  
**Selector lever: "D" position**  
**Gear position: 3rd ⇒ 4th Gear (FR/B ON/OFF)**  
**Driving location: Driving the vehicle uphill (increased engine load) will help maintain the driving conditions required for this test.**
3. Perform step "2" again.
4. Turn ignition switch "OFF", then perform step "1" to "3" again.
5. Check "SELF-DIAG RESULTS" mode for "A/T" with CONSULT-II. If DTC (P1759) is detected, refer to [AT-132, "Diagnostic Procedure"](#).  
 If DTC (P1757) is detected, go to [AT-130, "Diagnostic Procedure"](#).  
 If DTC (P1841) is detected, go to [AT-150, "Diagnostic Procedure"](#).

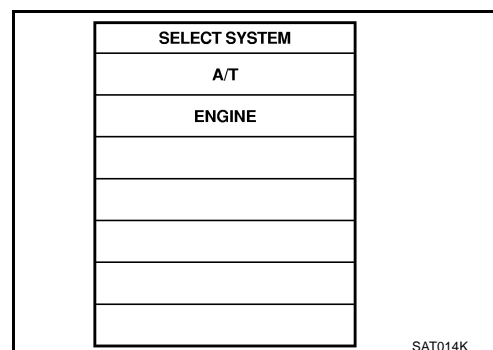

**WITH GST**

Follow the procedure "With CONSULT-II".

## Diagnostic Procedure

ACS003PR

### 1. CHECK INPUT SIGNALS

**With CONSULT-II**

1. Start engine.
2. Select "ECU INPUT SIGNALS" or "MAIN SIGNALS" in "DATA MONITOR" mode for "A/T" with CONSULT-II.
3. Drive vehicle in the "D" position (3rd ⇒ 4th gear), and confirm the ON/OFF actuation of the "ATF PRES SW 1".

Item name	Condition	Display value (ON-OFF display)
ATF PRES SW 1	Front brake operates. Refer to <a href="#">AT-17</a>	ON
	Other conditions	OFF

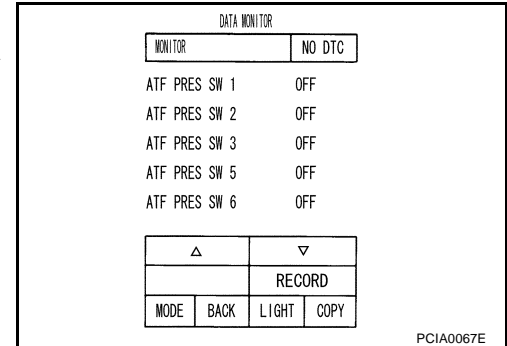

**With GST**

Follow the procedure "With CONSULT-II".

**OK or NG**

- OK >> GO TO 4.
- NG >> GO TO 2.

### 2. CHECK TCM

Perform TCM input/output signal inspection. Refer to [AT-74, "TCM Input/Output Signal Reference Values"](#) .

**OK or NG**

- OK >> GO TO 4.
- NG >> GO TO 3.

### 3. DETECT MALFUNCTIONING ITEM

Check the following items:

- Power supply and ground circuit for TCM.
- The A/T assembly harness connector pin terminals for damage or loose connection with harness connector.

**OK or NG**

- OK >> Replace the transmission assembly. Refer to [AT-192, "Removal and Installation"](#) .
- NG >> Repair or replace damaged parts.

### 4. CHECK DTC

Perform DTC Confirmation Procedure.

- Refer to [AT-132, "Diagnostic Procedure"](#) .

**OK or NG**

- OK >> **INSPECTION END**
- NG >> GO TO 2.

## DTC P1762 DIRECT CLUTCH SOLENOID VALVE

PFP:31940

### Description

ACS003PS

Direct clutch solenoid valve is controlled by the TCM in response to signals sent from the PNP switch, vehicle speed sensor and accelerator pedal position sensor (throttle position sensor). Gears will then be shifted to the optimum position.

### CONSULT-II Reference Value

ACS003PT

Item name	Condition	Display value (Approx) (A)
D/C SOLENOID	Direct clutch operates. Refer to <a href="#">AT-17</a>	0.6 - 0.8
	Other conditions	0 - 0.05

### On Board Diagnosis Logic

ACS003PU

- This is an OBD-II self-diagnostic item.
- Diagnostic trouble code "D/C SOLENOID/CIRC" with CONSULT-II or P1762 without CONSULT-II is detected under the following conditions.
  - When TCM detects an improper voltage drop when it tries to operate the solenoid valve.
  - When TCM detects as irregular by comparing target value with monitor value.

### Possible Cause

ACS003PV

- Harness or connectors  
(The solenoid circuit is open or shorted.)
- Direct clutch solenoid valve

### DTC Confirmation Procedure

ACS003PW

#### NOTE:

If "DTC Confirmation Procedure" has been previously performed, always turn ignition switch "OFF" and wait at least 10 seconds before performing the next test.

After the repair, perform the following procedure to confirm the malfunction is eliminated.

#### WITH CONSULT-II

1. Turn ignition switch "ON". (Do not start engine.)
2. Select "DATA MONITOR" mode for "A/T" with CONSULT-II.
3. Start engine.
4. Drive vehicle and maintain the following conditions for at least 5 consecutive seconds.
  - ACCELE POSI: 1.5/8 - 2.0/8**
  - Selector lever: "D" position**
  - Gear position: 1st ⇒ 2nd Gear (D/C ON/OFF)**
  - Driving location: Driving the vehicle uphill (increased engine load) will help maintain the driving conditions required for this test.**
5. If DTC is detected, go to [AT-134, "Diagnostic Procedure"](#).

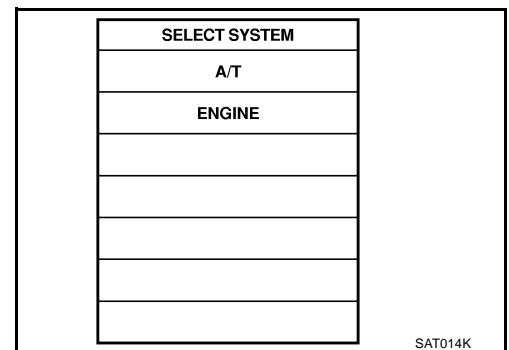

#### WITH GST

Follow the procedure "With CONSULT-II".

---

## Diagnostic Procedure

ACS003PX

### 1. CHECK TCM

---

Perform TCM input/output signal inspection. Refer to [AT-74, "TCM Input/Output Signal Reference Values"](#) .

OK or NG

- OK >> GO TO 3.
- NG >> GO TO 2.

### 2. DETECT MALFUNCTIONING ITEM

---

Check the following items:

- Power supply and ground circuit for TCM.
- The A/T assembly harness connector pin terminals for damage or loose connection with harness connector.

OK or NG

- OK >> Replace the transmission assembly. Refer to [AT-192, "Removal and Installation"](#) .
- NG >> Repair or replace damaged parts.

### 3. CHECK DTC

---

Perform DTC Confirmation Procedure.

- Refer to [AT-133, "DTC Confirmation Procedure"](#) .

OK or NG

- OK >> **INSPECTION END**
- NG >> GO TO 1.

## DTC P1764 DIRECT CLUTCH SOLENOID VALVE FUNCTION

PFP:31940

### Description

ACS003PY

- Direct clutch solenoid valve is controlled by the TCM in response to signals sent from the PNP switch, vehicle speed sensor and accelerator pedal position sensor (throttle position sensor). Gears will then be shifted to the optimum position.
- This is not only caused by electrical malfunction (circuits open or shorted) but also by mechanical malfunction such as control valve sticking, improper solenoid valve operation.

### CONSULT-II Reference Value

ACS003PZ

Item name	Condition	Display value (Approx) (A)
D/C SOLENOID	Direct clutch operates. Refer to <a href="#">AT-17</a>	0.6 - 0.8
	Other conditions	0 - 0.05

Item name	Condition	Display value (ON-OFF display)
ATF PRES SW 5	Direct clutch operates. Refer to <a href="#">AT-17</a>	ON
	Other conditions	OFF

### On Board Diagnosis Logic

ACS003Q0

- This is an OBD-II self-diagnostic item.
- Diagnostic trouble code “D/C SOLENOID FNCTN” with CONSULT-II or P1764 without CONSULT-II is detected under the following conditions.
  - When TCM detects that actual gear ratio is irregular, and relation between gear position and condition of ATF pressure switch 5 is irregular during depressing accelerator pedal. (Other than during shift change)
  - When TCM detects that relation between gear position and condition of ATF pressure switch 5 is irregular during releasing accelerator pedal. (Other than during shift change)

### Possible Cause

ACS003Q1

- Harness or connectors  
(The solenoid and switch circuits are open or shorted.)
- Direct clutch solenoid valve
- ATF pressure switch 5

### DTC Confirmation Procedure

ACS003Q2

#### NOTE:

If “DTC Confirmation Procedure” has been previously performed, always turn ignition switch “OFF” and wait at least 10 seconds before performing the next test.

After the repair, perform the following procedure to confirm the malfunction is eliminated.

#### Ⓟ WITH CONSULT-II

1. Start engine.
2. Accelerate vehicle to maintain the following conditions.  
**ACCELE POSI: 1.5/8 - 2.0/8**  
**Selector lever: “D” position**  
**Gear position: 1st ⇒ 2nd Gear (D/C ON/OFF)**  
**Driving location: Driving the vehicle uphill (increased engine load) will help maintain the driving conditions required for this test.**
3. Perform step “2” again.
4. Turn ignition switch “OFF”, then perform step “1” to “3” again.
5. Check “SELF-DIAG RESULTS” mode for “A/T” with CONSULT-II. If DTC (P1764) is detected, refer to [AT-136, "Diagnostic Procedure"](#) .  
 If DTC (P1762) is detected, go to [AT-134, "Diagnostic Procedure"](#) .  
 If DTC (P1845) is detected, go to [AT-154, "Diagnostic Procedure"](#) .

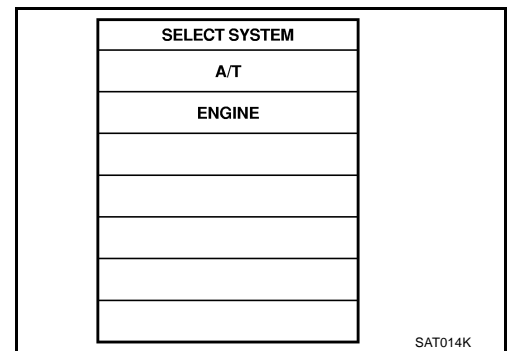

**WITH GST**

Follow the procedure "With CONSULT-II".

## Diagnostic Procedure

ACS003Q3

### 1. CHECK INPUT SIGNALS

With CONSULT-II

1. Start engine.
2. Select "ECU INPUT SIGNALS" or "MAIN SIGNALS" in "DATA MONITOR" mode for "A/T" with CONSULT-II.
3. Drive vehicle in the "D" position (1st ⇒ 2nd gear), and confirm the ON/OFF actuation of the "ATF PRES SW 5".

Item name	Condition	Display value (ON-OFF display)
ATF PRES SW 5	Direct clutch operates. Refer to <a href="#">AT-17</a>	ON
	Other conditions	OFF

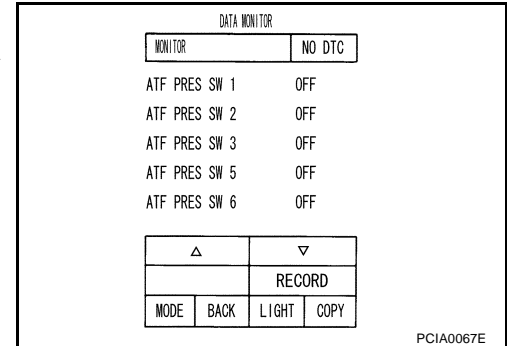

**With GST**

Follow the procedure "With CONSULT-II".

OK or NG

- OK >> GO TO 4.
- NG >> GO TO 2.

### 2. CHECK TCM

Perform TCM input/output signal inspection. Refer to [AT-74, "TCM Input/Output Signal Reference Values"](#) .

OK or NG

- OK >> GO TO 4.
- NG >> GO TO 3.

### 3. DETECT MALFUNCTIONING ITEM

Check the following items:

- Power supply and ground circuit for TCM.
- The A/T assembly harness connector pin terminals for damage or loose connection with harness connector.

OK or NG

- OK >> Replace the transmission assembly. Refer to [AT-192, "Removal and Installation"](#) .
- NG >> Repair or replace damaged parts.

### 4. CHECK DTC

Perform DTC Confirmation Procedure.

- Refer to [AT-135, "DTC Confirmation Procedure"](#) .

OK or NG

- OK >> **INSPECTION END**
- NG >> GO TO 2.



## DTC P1767 HIGH AND LOW REVERSE CLUTCH SOLENOID VALVE

PF3:31940

### Description

ACS003Q4

High and low reverse clutch solenoid valve is controlled by the TCM in response to signals sent from the PNP switch, vehicle speed sensor and accelerator pedal position sensor (throttle position sensor). Gears will then be shifted to the optimum position.

### CONSULT-II Reference Value

ACS003Q5

Item name	Condition	Display value (Approx) (A)
HLR/C SOL	High and low reverse clutch operates. Refer to <a href="#">AT-17</a>	0.6 - 0.8
	Other conditions	0 - 0.05

### On Board Diagnosis Logic

ACS003Q6

- This is an OBD-II self-diagnostic item.
- Diagnostic trouble code "HLR/C SOL/CIRC" with CONSULT-II or P1767 without CONSULT-II is detected under the following conditions.
  - When TCM detects an improper voltage drop when it tries to operate the solenoid valve.
  - When TCM detects as irregular by comparing target value with monitor value.

### Possible Cause

ACS003Q7

- Harness or connectors  
(The solenoid circuit is open or shorted.)
- High and low reverse clutch solenoid valve

### DTC Confirmation Procedure

ACS003Q8

#### CAUTION:

Always drive vehicle at a safe speed.

#### NOTE:

If "DTC Confirmation Procedure" has been previously performed, always turn ignition switch "OFF" and wait at least 10 seconds before performing the next test.

After the repair, perform the following procedure to confirm the malfunction is eliminated.

#### ⓑ WITH CONSULT-II

1. Turn ignition switch "ON". (Do not start engine.)
2. Select "DATA MONITOR" mode for "A/T" with CONSULT-II.
3. Start engine.
4. Drive vehicle and maintain the following conditions for at least 5 consecutive seconds.
  - ACCELE POSI: 1.5/8 - 2.0/8**
  - Selector lever: "D" position**
  - Gear position: 2nd ⇒ 3rd Gear (HLR/C ON/OFF)**
  - Driving location: Driving the vehicle uphill (increased engine load) will help maintain the driving conditions required for this test.**
5. If DTC is detected, go to [AT-138, "Diagnostic Procedure"](#).

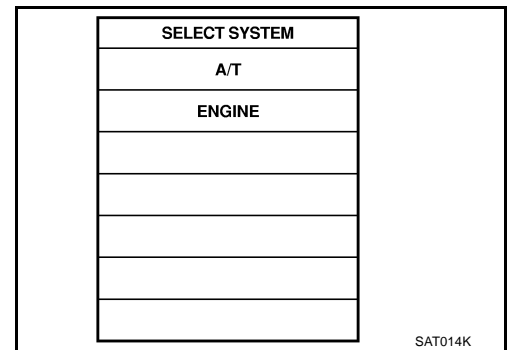

#### Ⓒ WITH GST

Follow the procedure "With CONSULT-II".

---

## Diagnostic Procedure

ACS003Q9

### 1. CHECK TCM

---

Perform TCM input/output signal inspection. Refer to [AT-74, "TCM Input/Output Signal Reference Values"](#) .

OK or NG

- OK >> GO TO 3.
- NG >> GO TO 2.

### 2. DETECT MALFUNCTIONING ITEM

---

Check the following items:

- Power supply and ground circuit for TCM.
- The A/T assembly harness connector pin terminals for damage or loose connection with harness connector.

OK or NG

- OK >> Replace the transmission assembly. Refer to [AT-192, "Removal and Installation"](#) .
- NG >> Repair or replace damaged parts.

### 3. CHECK DTC

---

Perform DTC Confirmation Procedure.

- Refer to [AT-137, "DTC Confirmation Procedure"](#) .

OK or NG

- OK >> **INSPECTION END**
- NG >> GO TO 1.

## DTC P1769 HIGH AND LOW REVERSE CLUTCH SOLENOID VALVE FUNCTION

PF3:31940

### Description

ACS003QA

- High and low reverse clutch solenoid valve is controlled by the TCM in response to signals sent from the PNP switch, vehicle speed sensor and accelerator pedal position sensor (throttle position sensor). Gears will then be shifted to the optimum position.
- This is not only caused by electrical malfunction (circuits open or shorted) but also by mechanical malfunction such as control valve sticking, improper solenoid valve operation.

### CONSULT-II Reference Value

ACS003QB

Item name	Condition	Display value (Approx) (A)
HLR/C SOL	High and low reverse clutch operates. Refer to <a href="#">AT-17</a>	0.6 - 0.8
	Other conditions	0 - 0.05

Item name	Condition	Display value (ON-OFF display)
ATF PRES SW 6	High and low reverse clutch operates. Refer to <a href="#">AT-17</a>	ON
	Other conditions	OFF

### On Board Diagnosis Logic

ACS003QC

- This is an OBD-II self-diagnostic item.
- Diagnostic trouble code “HLR/C SOL FNCTN” with CONSULT-II or P1769 without CONSULT-II is detected under the following conditions.
  - When TCM detects that actual gear ratio is irregular, and relation between gear position and condition of ATF pressure switch 6 is irregular during depressing accelerator pedal. (Other than during shift change)
  - When TCM detects that relation between gear position and condition of ATF pressure switch 6 is irregular during releasing accelerator pedal. (Other than during shift change)

### Possible Cause

ACS003QD

- Harness or connectors  
(The solenoid and switch circuits are open or shorted.)
- High and low reverse clutch solenoid valve
- ATF pressure switch 6

### DTC Confirmation Procedure

ACS003QE

#### CAUTION:

Always drive vehicle at a safe speed.

#### NOTE:

If “DTC Confirmation Procedure” has been previously performed, always turn ignition switch “OFF” and wait at least 10 seconds before performing the next test.

After the repair, perform the following procedure to confirm the malfunction is eliminated.

#### Ⓟ WITH CONSULT-II

1. Start engine.
2. Accelerate vehicle to maintain the following conditions.  
**ACCELE POSI: 1.5/8 - 2.0/8**  
**Selector lever: “D” position**  
**Gear position: 2nd ⇒ 3rd Gear (HLR/C ON/OFF)**  
**Driving location: Driving the vehicle uphill (increased engine load) will help maintain the driving conditions required for this test.**
3. Perform step “2” again.
4. Turn ignition switch “OFF”, then perform step “1” to “3” again.
5. Check “SELF-DIAG RESULTS” mode for “A/T” with CONSULT-II. If DTC (P1769) is detected, refer to [AT-140, "Diagnostic Procedure"](#) .  
 If DTC (P1767) is detected, go to [AT-138, "Diagnostic Procedure"](#) .

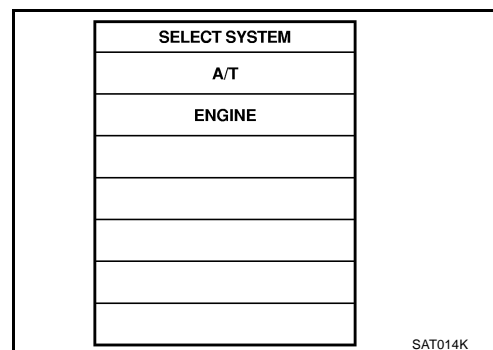

If DTC (P1846) is detected, go to [AT-156, "Diagnostic Procedure"](#) .

## WITH GST

Follow the procedure "With CONSULT-II".

## Diagnostic Procedure

ACS003QF

### 1. CHECK INPUT SIGNALS

#### With CONSULT-II

1. Start the engine.
2. Select "ECU INPUT SIGNALS" or "MAIN SIGNALS" in "DATA MONITOR" mode for "A/T" with CONSULT-II.
3. Drive vehicle in the "D" position (2nd ⇒ 3rd gear), and confirm the ON/OFF actuation of the "ATF PRES SW 6".

DATA MONITOR			
MONITOR		NO DTC	
ATF PRES SW 1		OFF	
ATF PRES SW 2		OFF	
ATF PRES SW 3		OFF	
ATF PRES SW 5		OFF	
ATF PRES SW 6		OFF	
△		▽	
RECORD			
MODE	BACK	LIGHT	COPY

PCIA0067E

Item name	Condition	Display value (ON-OFF display)
ATF PRES SW 6	High and low reverse clutch operates. Refer to <a href="#">AT-17</a>	ON
	Other conditions	OFF

#### With GST

Follow the procedure "With CONSULT-II".

#### OK or NG

- OK >> GO TO 4.
- NG >> GO TO 2.

### 2. CHECK TCM

Perform TCM input/output signal inspection. Refer to [AT-74, "TCM Input/Output Signal Reference Values"](#) .

#### OK or NG

- OK >> GO TO 4.
- NG >> GO TO 3.

### 3. DETECT MALFUNCTIONING ITEM

Check the following items:

- Power supply and ground circuit for TCM.
- The A/T assembly harness connector pin terminals for damage or loose connection with harness connector.

#### OK or NG

- OK >> Replace the transmission assembly. Refer to [AT-192, "Removal and Installation"](#) .
- NG >> Repair or replace damaged parts.

### 4. CHECK DTC

Perform DTC Confirmation Procedure.

- Refer to [AT-139, "DTC Confirmation Procedure"](#) .

#### OK or NG

- OK >> **INSPECTION END**
- NG >> GO TO 2.

## DTC P1772 LOW COAST BRAKE SOLENOID VALVE

PFP:31940

### Description

ACS003QG

Low coast brake solenoid valve is turned “ON” or “OFF” by the TCM in response to signals sent from the PNP switch, vehicle speed sensor and accelerator pedal position sensor (throttle position sensor). Gears will then be shifted to the optimum position.

### CONSULT-II Reference Value

ACS003QH

Item name	Condition	Display value (ON-OFF display)
ON OFF SOL	Low coast brake operates. Refer to <a href="#">AT-17</a>	ON
	Other conditions	OFF

### On Board Diagnosis Logic

ACS003QI

- This is an OBD-II self-diagnostic item.
- Diagnostic trouble code “LC/B SOLENOID/CIRC” with CONSULT-II or P1772 without CONSULT-II is detected when TCM detects an improper voltage drop when it tries to operate the solenoid valve.

### Possible Cause

ACS003QJ

- Harness or connectors  
(The solenoid circuit is open or shorted.)
- Low coast brake solenoid valve

### DTC Confirmation Procedure

ACS003QK

#### NOTE:

**If “DTC Confirmation Procedure” has been previously performed, always turn ignition switch “OFF” and wait at least 10 seconds before performing the next test.**

After the repair, perform the following procedure to confirm the malfunction is eliminated.

#### WITH CONSULT-II

1. Turn ignition switch “ON”. (Do not start engine.)
2. Select “DATA MONITOR” mode for “ENGINE” with CONSULT-II.
3. Start engine.
4. Drive vehicle and maintain the following conditions for at least 5 consecutive seconds.  
**Selector lever: “M” position**  
**Gear position: “M1-1st” or “M2-2nd” gear (LC/B ON/OFF)**
5. If DTC is detected, go to [AT-142, "Diagnostic Procedure"](#) .

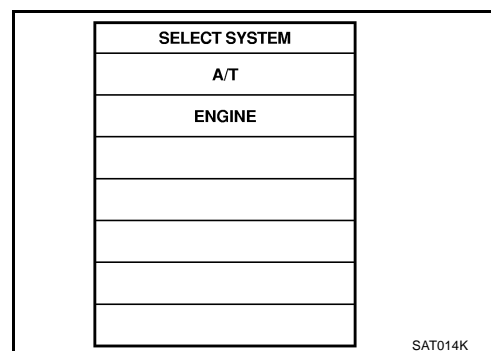

#### WITH GST

Follow the procedure “With CONSULT-II”.

---

## Diagnostic Procedure

ACS003QL

### 1. CHECK TCM

---

Perform TCM input/output signal inspection. Refer to [AT-74, "TCM Input/Output Signal Reference Values"](#) .

OK or NG

- OK >> GO TO 3.
- NG >> GO TO 2.

### 2. DETECT MALFUNCTIONING ITEM

---

Check the following items:

- Power supply and ground circuit for TCM.
- The A/T assembly harness connector pin terminals for damage or loose connection with harness connector.

OK or NG

- OK >> Replace the transmission assembly. Refer to [AT-192, "Removal and Installation"](#) .
- NG >> Repair or replace damaged parts.

### 3. CHECK DTC

---

Perform DTC Confirmation Procedure.

- Refer to [AT-141, "DTC Confirmation Procedure"](#) .

OK or NG

- OK >> **INSPECTION END**
- NG >> GO TO 1.

## DTC P1774 LOW COAST BRAKE SOLENOID VALVE FUNCTION

PFP:31940

### Description

ACS003QM

- Low coast brake solenoid valve is turned “ON” or “OFF” by the TCM in response to signals sent from the PNP switch, vehicle speed sensor and accelerator pedal position sensor (throttle position sensor). Gears will then be shifted to the optimum position.
- This is not only caused by electrical malfunction (circuits open or shorted) but also by mechanical malfunction such as control valve sticking, improper solenoid valve operation.

### CONSULT-II Reference Value

ACS003QN

Item name	Condition	Display value (ON-OFF display)
ON OFF SOL	Low coast brake operates. Refer to <a href="#">AT-17</a>	ON
	Other conditions	OFF

Item name	Condition	Display value (ON-OFF display)
ATF PRES SW 2	Low coast brake operates. Refer to <a href="#">AT-17</a>	ON
	Other conditions	OFF

### On Board Diagnosis Logic

ACS003QO

- This is an OBD-II self-diagnostic item.
- Diagnostic trouble code “LC/B SOLENOID FNCT” with CONSULT-II or P1774 without CONSULT-II is detected under the following conditions.
  - When TCM detects that actual gear ratio is irregular, and relation between gear position and condition of ATF pressure switch 2 is irregular during depressing accelerator pedal. (Other than during shift change)
  - When TCM detects that relation between gear position and condition of ATF pressure switch 2 is irregular during releasing accelerator pedal. (Other than during shift change)

### Possible Cause

ACS003QP

- Harness or connectors  
(The solenoid and switch circuits are open or shorted.)
- Low coast brake solenoid valve
- ATF pressure switch 2

### DTC Confirmation Procedure

ACS003QQ

#### CAUTION:

**Always drive vehicle at a safe speed.**

#### NOTE:

**If “DTC Confirmation Procedure” has been previously performed, always turn ignition switch “OFF” and wait at least 10 seconds before performing the next test.**

After the repair, perform the following procedure to confirm the malfunction is eliminated.

#### WITH CONSULT-II

1. Start engine.
2. Accelerate vehicle to maintain the following conditions.  
**Selector lever: “M” position**  
**Gear position: “M1-1st” or “M2-2nd” gear (LC/B ON/OFF)**
3. Perform step “2” again.
4. Turn ignition switch “OFF”, then perform step “1” to “3” again.
5. Check “SELF-DIAG RESULTS” mode for “A/T” with CONSULT-II. If DTC (P1774) is detected, refer to [AT-144, "Diagnostic Procedure"](#).  
 If DTC (P1772) is detected, go to [AT-142, "Diagnostic Procedure"](#).

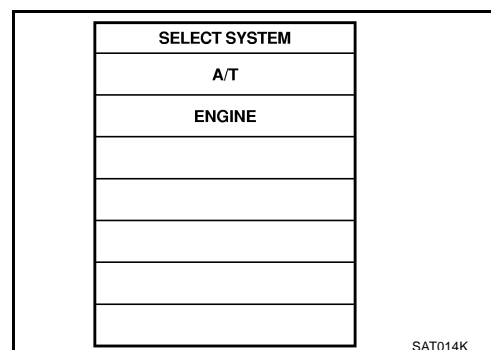

#### WITH GST

Follow the procedure “With CONSULT-II”.

## Diagnostic Procedure

ACS003QR

### 1. CHECK INPUT SIGNALS

#### With CONSULT-II

1. Start the engine.
2. Select "ECU INPUT SIGNALS" or "MAIN SIGNALS" in "DATA MONITOR" mode for "A/T" with CONSULT-II.
3. Drive vehicle in the manual mode ("M1-1st" or "M2-2nd" gear), and confirm the ON/OFF actuation of the "ATF PRES SW 2".

DATA MONITOR			
MONITOR		NO. DTC	
ATF PRES SW 1		OFF	
ATF PRES SW 2		OFF	
ATF PRES SW 3		OFF	
ATF PRES SW 5		OFF	
ATF PRES SW 6		OFF	

△	▽
RECORD	
MODE	COPY

PCIA0067E

Item name	Condition	Display value (ON-OFF display)
ATF PRES SW 2	Low coast brake operates. Refer to <a href="#">AT-17</a>	ON
	Other conditions	OFF

#### With GST

Follow the procedure "With CONSULT-II".

#### OK or NG

- OK >> GO TO 4.
- NG >> GO TO 2.

### 2. CHECK TCM

Perform TCM input/output signal inspection. Refer to [AT-74, "TCM Input/Output Signal Reference Values"](#) .

#### OK or NG

- OK >> GO TO 4.
- NG >> GO TO 3.

### 3. DETECT MALFUNCTIONING ITEM

Check the following items:

- Power supply and ground circuit for TCM.
- The A/T assembly harness connector pin terminals for damage or loose connection with harness connector.

#### OK or NG

- OK >> Replace the transmission assembly. Refer to [AT-192, "Removal and Installation"](#) .
- NG >> Repair or replace damaged parts.

### 4. CHECK DTC

Perform DTC Confirmation Procedure.

- Refer to [AT-143, "DTC Confirmation Procedure"](#) .

#### OK or NG

- OK >> **INSPECTION END**
- NG >> GO TO 2.



## DTC P1815 MANUAL MODE SWITCH

PFP:34901

### Description

ACS004YC

Manual mode switch is installed in A/T device. It sends manual mode switch, shift up and shift down switch signals to TCM.

TCM sends the switch signals to unified meter and A/C amp. By CAN communication line. Then manual mode switch position is indicated on the A/T indicator. For inspection, refer to [AT-147, "Position Indicator Lamp"](#).

### CONSULT-II Reference Value in Data Monitor Mode

ACS003QT

Monitor Item	Condition	Reference Value
MANU MODE SW [ON - OFF]	Manual shift gate position (neutral)	ON
	Other than the above	OFF
NON M-MODE SW [ON - OFF]	Manual shift gate position	OFF
	Other than the above	ON
UP SW LEVER [ON - OFF]	Select lever: + side	ON
	Other than the above	OFF
DOWN SW LEVER [ON - OFF]	Select lever: - side	ON
	Other than the above	OFF

### On Board Diagnosis Logic

ACS003QU

- This is not an OBD-II self-diagnostic item.
- Diagnostic trouble code "MANU MODE SW/CIR" with CONSULT-II is detected when TCM monitors Manual mode, Non manual mode, Up or Down switch signal, and detects as irregular when impossible input pattern occurs 1 second or more.

### Possible Cause

ACS003QV

- Harness or connectors (These switches circuit is open or shorted.)
- Mode select switch (Into control device)
- Position select switch (Into control device)

### DTC Confirmation Procedure

ACS003QW

#### NOTE:

If "DTC Confirmation Procedure" has been previously performed, always turn ignition switch "OFF" and wait at least 10 seconds before performing the next test.

After the repair, perform the following procedure to confirm the malfunction is eliminated.

#### WITH CONSULT-II

1. Turn ignition switch "ON". (Do not start engine.)
2. Select "DATA MONITOR" mode for "A/T" with CONSULT-II.
3. Start engine.
4. Move selector lever to "M" position.
5. Drive vehicle for at least 2 consecutive seconds.
6. If DTC is detected, go to [AT-146, "Diagnostic Procedure"](#).

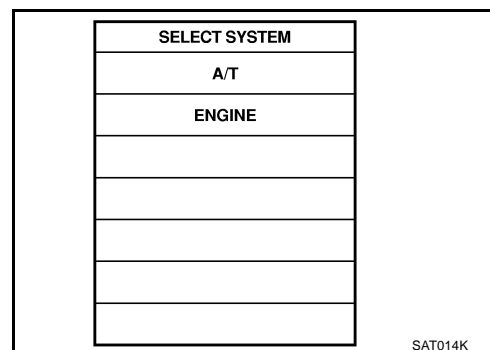

## Diagnostic Procedure

ACS0030X

### 1. CHECK CAN COMMUNICATION LINE

Perform the self-diagnosis. Refer to [AT-76, "SELF-DIAGNOSTIC PROCEDURE \(WITH CONSULT-II\)"](#) .

Is a malfunction in the CAN communication indicated in the results?

- YES >> Check CAN communication line. Refer to [AT-89, "DTC U1000 CAN COMMUNICATION LINE"](#) .
- NO >> GO TO 2.

### 2. CHECK MANUAL MODE SWITCH CIRCUIT

#### With CONSULT-II

1. Turn ignition switch "ON". (Do not start engine.)
2. Select "UNIFIED METER AND A/C AMP INPUT SIGNALS" in "DATA MONITOR" mode for "METER A/C AMP" with CONSULT-II.
3. Read out ON/OFF switching action of the "AT-M GEAR".

DATA MONITOR	
MONITOR	
AT-M IND	OFF
AT-M GEAR	OFF
P RANGE IND	ON
R RANGE IND	OFF
N RANGE IND	OFF
D RANGE IND	OFF

PKIA2062E

#### Without CONSULT-II

Drive vehicle in the manual mode, and confirm that the actual gear position and the meter's indication of the position mutually coincide when the selector lever is shifted to the "+" (up) or "-" (down) side (1st ⇔ 5th gear).

OK or NG

- OK >> GO TO 6.
- NG >> GO TO 3.

### 3. DETECT MALFUNCTIONING ITEM

Check the following items.

- Manual mode switch. Refer to [AT-147, "Component Inspection"](#) .
- Pin terminals for damage or loose connection with harness connector.
- Open circuit or short to ground or short to power in harness or connector for A/T device (manual mode switch).

OK or NG

- OK >> GO TO 4.
- NG >> Repair or replace damaged parts.

### 4. CHECK TCM

Perform TCM input/output signal inspection. Refer to [AT-74, "TCM Input/Output Signal Reference Values"](#) .

OK or NG

- OK >> GO TO 6.
- NG >> GO TO 5.

## 5. DETECT MALFUNCTIONING ITEM

Check the following items:

- Power supply and ground circuit for TCM.
- The A/T assembly harness connector pin terminals for damage or loose connection with harness connector.

OK or NG

- OK >> Replace the transmission assembly. Refer to [AT-192, "Removal and Installation"](#) .  
 NG >> Repair or replace damaged parts.

## 6. CHECK DTC

Perform DTC Confirmation Procedure.

- Refer to [AT-145, "DTC Confirmation Procedure"](#) .

OK or NG

- OK >> **INSPECTION END**  
 NG >> GO TO 4.

## Component Inspection MANUAL MODE SWITCH

ACS003QY

Check continuity between terminals.

Item	Position	Connector No.	Terminal No. (Unit side)	Continuity
Manual mode (select) switch	Auto	M47	9 - 10	Yes
	Manual		6 - 9	
UP switch	UP		8 - 9	
DOWN switch	DOWN		7 - 9	

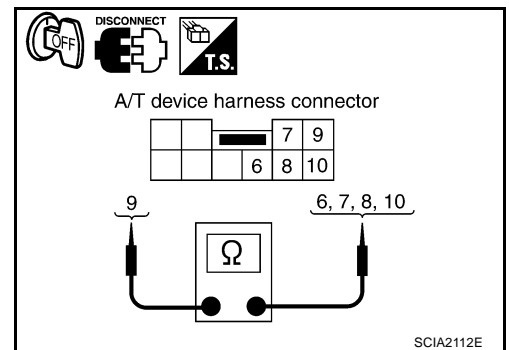

## Position Indicator Lamp DIAGNOSTIC PROCEDURE

ACS003QZ

### 1. CHECK INPUT SIGNALS (WITH CONSULT-II)

Ⓟ With CONSULT-II

1. Start engine.
2. Select "MAIN SIGNALS" in "DATA MONITOR" mode for A/T with CONSULT-II and read out the value of "GEAR".
3. Drive vehicle in the manual mode, and confirm that the actual gear position and the meter's indication of the position mutually coincide when the select lever is shifted to the "+ (up)" or "- (down)" side (1st ⇔ 5th gear).

OK or NG

- OK >> **INSPECTION END**  
 NG >> Check the following items.

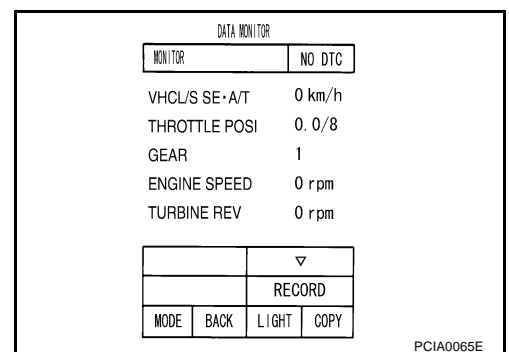

### Position indicator lamp symptom chart

Items	Presumed Location of Trouble
<p>The actual gear position does not change, or shifting into the manual mode is not possible (no gear shifting in the manual mode possible). The position indicator lamp is not indicated.</p>	<p>Manual mode switch Refer to <a href="#">AT-145. "DTC P1815 MANUAL MODE SWITCH"</a> . A/T main system (Fail-safe function actuated)</p> <ul style="list-style-type: none"> <li>● Refer to <a href="#">AT-76. "SELF-DIAGNOSTIC PROCEDURE (WITH CONSULT-II)"</a> .</li> </ul>
<p>The actual gear position changes, but the position indicator lamp is not indicated.</p>	<p>Perform the self-diagnosis function.</p> <ul style="list-style-type: none"> <li>● Refer to <a href="#">AT-76. "SELF-DIAGNOSTIC PROCEDURE (WITH CONSULT-II)"</a> .</li> </ul>
<p>The actual gear position and the indication on the position indicator lamp do not coincide.</p>	<p>Perform the self-diagnosis function.</p> <ul style="list-style-type: none"> <li>● Refer to <a href="#">AT-76. "SELF-DIAGNOSTIC PROCEDURE (WITH CONSULT-II)"</a> .</li> </ul>
<p>Only a specific position or positions is/are not indicated on the position indicator lamp.</p>	<p>Check the unified meter and A/C amp. Refer to <a href="#">DI-4. "COMBINATION METERS"</a> .</p>

## DTC P1841 ATF PRESSURE SWITCH 1

PDF:25240

### Description

ACS003R0

Fail-safe function to detect front brake clutch solenoid valve condition.

### CONSULT-II Reference Value

ACS003R1

Item name	Condition	Display value (ON-OFF display)
ATF PRES SW 1	Front brake operates. Refer to <a href="#">AT-17</a>	ON
	Other conditions	OFF

### On Board Diagnosis Logic

ACS003R2

- This is not an OBD-II self-diagnostic item.
- Diagnostic trouble code “ATF PRES SW 1/CIRC” with CONSULT-II is detected when TCM detects that actual gear ratio is normal, and relation between gear position and condition of ATF pressure switch 1 is irregular during depressing accelerator pedal. (Other than during shift change)

### Possible Cause

ACS003R3

- ATF pressure switch 1
- Harness or connectors  
(The switch circuit is open or shorted.)

### DTC Confirmation Procedure

ACS003R4

#### CAUTION:

Always drive vehicle at a safe speed.

#### NOTE:

If “DTC Confirmation Procedure” has been previously performed, always turn ignition switch “OFF” and wait at least 10 seconds before performing the next test.

After the repair, perform the following procedure to confirm the malfunction is eliminated.

#### Ⓟ WITH CONSULT-II

1. Start engine.
2. Accelerate vehicle to maintain the following conditions.  
**ACCELE POSI: 1.5/8 - 2.0/8**  
**Selector lever: “D” position**  
**Gear position: 3rd ⇒ 4th Gear (FR/B ON/OFF)**  
**Driving location: Driving the vehicle uphill (increased engine load) will help maintain the driving conditions required for this test.**
3. Perform step “2” again.
4. Turn ignition switch “OFF”, then perform step “1” to “3” again.
5. Check “SELF-DIAG RESULTS” mode for “A/T” with CONSULT-II.

If DTC (P1841) is detected, go to [AT-150. "Diagnostic Procedure"](#) .

If DTC (P1757) is detected, go to [AT-130. "Diagnostic Procedure"](#) .

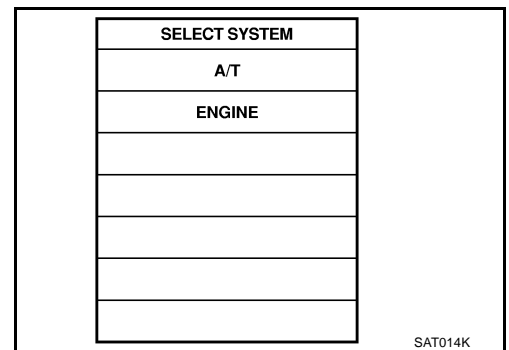

## Diagnostic Procedure

### 1. CHECK INPUT SIGNALS

#### With CONSULT-II

1. Start engine.
2. Select "ECU INPUT SIGNALS" or "MAIN SIGNALS" in "DATA MONITOR" mode for "A/T" with CONSULT-II.
3. Drive vehicle in the "D" position (3rd ⇒ 4th gear), and confirm the ON/OFF actuation of the "ATF PRES SW 1".

Item name	Condition	Display value (ON-OFF display)
ATF PRES SW 1	Front brake operates. Refer to <a href="#">AT-17</a>	ON
	Other conditions	OFF

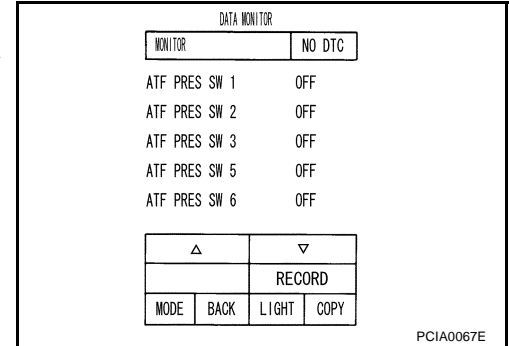

#### OK or NG

- OK >> GO TO 4.
- NG >> GO TO 2.

### 2. CHECK TCM

Perform TCM input/output signal inspection. Refer to [AT-74, "TCM Input/Output Signal Reference Values"](#).

#### OK or NG

- OK >> GO TO 4.
- NG >> GO TO 3.

### 3. DETECT MALFUNCTIONING ITEM

Check the following items:

- Power supply and ground circuit for TCM.
- A/T assembly harness connector pin terminals for damage or loose connection with harness connector.

#### OK or NG

- OK >> Replace the transmission assembly. Refer to [AT-192, "Removal and Installation"](#).
- NG >> Repair or replace damaged parts.

### 4. CHECK DTC

Perform DTC Confirmation Procedure.

- Refer to [AT-149, "DTC Confirmation Procedure"](#).

#### OK or NG

- OK >> **INSPECTION END**
- NG >> GO TO 2.

## DTC P1843 ATF PRESSURE SWITCH 3

PDF:25240

### Description

ACS003R6

Fail-safe function to detect input clutch solenoid valve condition.

### CONSULT-II Reference Value

ACS003R7

Item name	Condition	Display value (ON-OFF display)
ATF PRES SW 3	Input clutch operates. Refer to <a href="#">AT-17</a>	ON
	Other conditions	OFF

### On Board Diagnosis Logic

ACS003R8

- This is not an OBD-II self-diagnostic item.
- Diagnostic trouble code “ATF PRES SW 3/CIRC” with CONSULT-II is detected when TCM detects that actual gear ratio is normal, and relation between gear position and condition of ATF pressure switch 3 is irregular during depressing accelerator pedal. (Other than during shift change)

### Possible Cause

ACS003R9

- ATF pressure switch 3
- Harness or connectors  
(The switch circuit is open or shorted.)

### DTC Confirmation Procedure

ACS003RA

#### CAUTION:

Always drive vehicle at a safe speed.

#### NOTE:

If “DTC Confirmation Procedure” has been previously performed, always turn ignition switch “OFF” and wait at least 10 seconds before performing the next test.

After the repair, perform the following procedure to confirm the malfunction is eliminated.

#### Ⓟ WITH CONSULT-II

1. Start engine.
2. Accelerate vehicle to maintain the following conditions.  
**ACCELE POSI: 1.5/8 - 2.0/8**  
**Selector lever: “D” position**  
**Gear position: 3rd ⇒ 4th Gear (I/C ON/OFF)**  
**Driving location: Driving the vehicle uphill (increased engine load) will help maintain the driving conditions required for this test.**
3. Perform step “2” again.
4. Turn ignition switch “OFF”, then perform step “1” to “3” again.
5. Check “SELF-DIAG RESULTS” mode for “A/T” with CONSULT-II.

If DTC (P1843) is detected, go to [AT-152. "Diagnostic Procedure"](#) .

If DTC (P1752) is detected, go to [AT-126. "Diagnostic Procedure"](#) .

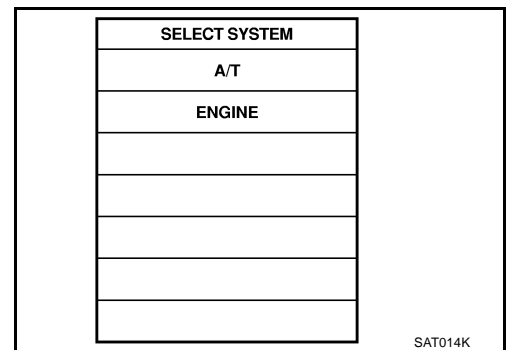

## Diagnostic Procedure

### 1. CHECK INPUT SIGNALS

#### With CONSULT-II

1. Start engine.
2. Select "ECU INPUT SIGNALS" or "MAIN SIGNALS" in "DATA MONITOR" mode for "A/T" with CONSULT-II.
3. Drive vehicle in the "D" position (3rd ⇒ 4th gear), and confirm the ON/OFF actuation of the "ATF PRES SW 3".

Item name	Condition	Display value (ON-OFF display)
ATF PRES SW 3	Input clutch operates. Refer to <a href="#">AT-17</a>	ON
	Other conditions	OFF

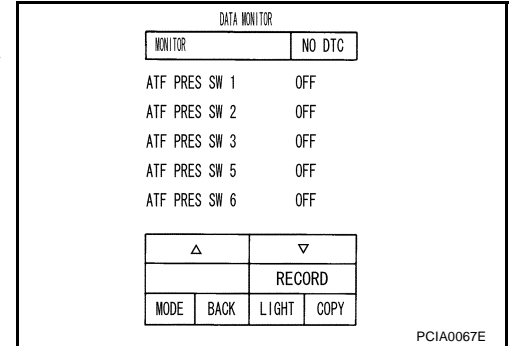

#### OK or NG

- OK >> GO TO 4.
- NG >> GO TO 2.

### 2. CHECK TCM

Perform TCM input/output signal inspection. Refer to [AT-74, "TCM Input/Output Signal Reference Values"](#) .

#### OK or NG

- OK >> GO TO 4.
- NG >> GO TO 3.

### 3. DETECT MALFUNCTIONING ITEM

Check the following items:

- Power supply and ground circuit for TCM.
- A/T assembly harness connector pin terminals for damage or loose connection with harness connector.

#### OK or NG

- OK >> Replace the transmission assembly. Refer to [AT-192, "Removal and Installation"](#) .
- NG >> Repair or replace damaged parts.

### 4. CHECK DTC

Perform DTC Confirmation Procedure.

- Refer to [AT-151, "DTC Confirmation Procedure"](#) .

#### OK or NG

- OK >> **INSPECTION END**
- NG >> GO TO 2.



## DTC P1845 ATF PRESSURE SWITCH 5

PDF:25240

### Description

ACS003RC

Fail-safe function to detect direct clutch solenoid valve condition.

### CONSULT-II Reference Value

ACS003RD

Item name	Condition	Display value (ON-OFF display)
ATF PRES SW 5	Direct clutch operates. Refer to <a href="#">AT-17</a>	ON
	Other conditions	OFF

### On Board Diagnosis Logic

ACS003RE

- This is not an OBD-II self-diagnostic item.
- Diagnostic trouble code “ATF PRES SW 5/CIRC” with CONSULT-II is detected when TCM detects that actual gear ratio is normal, and relation between gear position and condition of ATF pressure switch 5 is irregular during depressing accelerator pedal. (Other than during shift change)

### Possible Cause

ACS003RF

- ATF pressure switch 5
- Harness or connectors  
(The switch circuit is open or shorted.)

### DTC Confirmation Procedure

ACS003RG

#### CAUTION:

Always drive vehicle at a safe speed.

#### NOTE:

If “DTC Confirmation Procedure” has been previously performed, always turn ignition switch “OFF” and wait at least 10 seconds before performing the next test.

After the repair, perform the following procedure to confirm the malfunction is eliminated.

#### Ⓟ WITH CONSULT-II

1. Start engine.
2. Accelerate vehicle to maintain the following conditions.  
**ACCELE POSI: 1.5/8 - 2.0/8**  
**Selector lever: “D” position**  
**Gear position: 1st ⇒ 2nd Gear (D/C ON/OFF)**  
**Driving location: Driving the vehicle uphill (increased engine load) will help maintain the driving conditions required for this test.**
3. Perform step “2” again.
4. Turn ignition switch “OFF”, then perform step “1” to “3” again.
5. Check “SELF-DIAG RESULTS” mode for “A/T” with CONSULT-II.

If DTC (P1845) is detected, go to [AT-154, "Diagnostic Procedure"](#) .

If DTC (P1762) is detected, go to [AT-134, "Diagnostic Procedure"](#) .

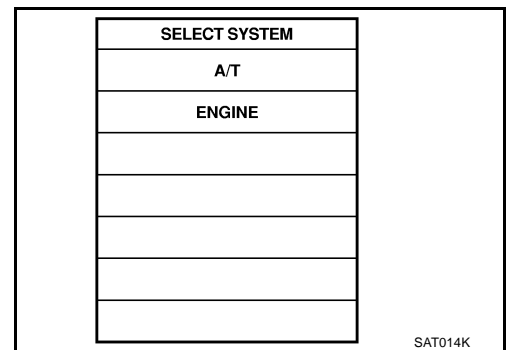

## Diagnostic Procedure

### 1. CHECK INPUT SIGNALS

④ With CONSULT-II

1. Start engine.
2. Select "ECU INPUT SIGNALS" or "MAIN SIGNALS" in "DATA MONITOR" mode for "A/T" with CONSULT-II.
3. Drive vehicle in the "D" position (1st ⇒ 2nd gear), and confirm the ON/OFF actuation of the "ATF PRES SW 5".

Item name	Condition	Display value (ON-OFF display)
ATF PRES SW 5	Direct clutch operates. Refer to <a href="#">AT-17</a>	ON
	Other conditions	OFF

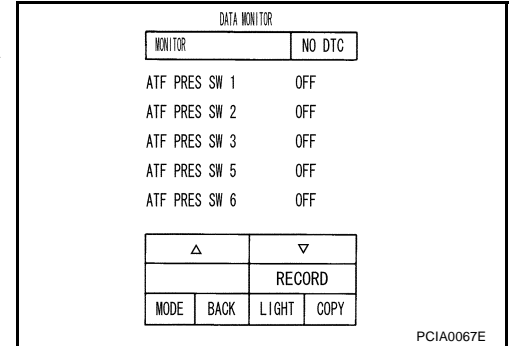

OK or NG

- OK >> GO TO 4.
- NG >> GO TO 2.

### 2. CHECK TCM

Perform TCM input/output signal inspection. Refer to [AT-74, "TCM Input/Output Signal Reference Values"](#) .

OK or NG

- OK >> GO TO 4.
- NG >> GO TO 3.

### 3. DETECT MALFUNCTIONING ITEM

Check the following items:

- Power supply and ground circuit for TCM.
- A/T assembly harness connector pin terminals for damage or loose connection with harness connector.

OK or NG

- OK >> Replace the transmission assembly. Refer to [AT-192, "Removal and Installation"](#) .
- NG >> Repair or replace damaged parts.

### 4. CHECK DTC

Perform DTC Confirmation Procedure.

- Refer to [AT-153, "DTC Confirmation Procedure"](#) .

OK or NG

- OK >> **INSPECTION END**
- NG >> GO TO 2.

## DTC P1846 ATF PRESSURE SWITCH 6

PDF:25240

### Description

ACS003RI

Fail-safe function to detect high and low reverse clutch solenoid valve condition.

### CONSULT-II Reference Value

ACS003RJ

Item name	Condition	Display value (ON-OFF display)
ATF PRES SW 6	High and low reverse clutch operates. Refer to <a href="#">AT-17</a>	ON
	Other conditions	OFF

### On Board Diagnosis Logic

ACS003RK

- This is not an OBD-II self-diagnostic item.
- Diagnostic trouble code “ATF PRES SW 6/CIRC” with CONSULT-II is detected when TCM detects that actual gear ratio is normal, and relation between gear position and condition of ATF pressure switch 6 is irregular during depressing accelerator pedal. (Other than during shift change)

### Possible Cause

ACS003RL

- ATF pressure switch 6
- Harness or connectors  
(The switch circuit is open or shorted.)

### DTC Confirmation Procedure

ACS003RM

#### CAUTION:

Always drive vehicle at a safe speed.

#### NOTE:

If “DTC Confirmation Procedure” has been previously performed, always turn ignition switch “OFF” and wait at least 10 seconds before performing the next test.

After the repair, perform the following procedure to confirm the malfunction is eliminated.

#### Ⓟ WITH CONSULT-II

1. Start engine.
2. Accelerate vehicle to maintain the following conditions.  
**ACCELE POSI: 1.5/8 - 2.0/8**  
**Selector lever: “D” position**  
**Gear position: 2nd ⇒ 3rd Gear (HLR/C ON/OFF)**  
**Driving location: Driving the vehicle uphill (increased engine load) will help maintain the driving conditions required for this test.**
3. Perform step “2” again.
4. Turn ignition switch “OFF”, then perform step “1” to “3” again.
5. Check “SELF-DIAG RESULTS” mode for “A/T” with CONSULT-II.

If DTC (P1846) is detected, go to [AT-156. "Diagnostic Procedure"](#) .

If DTC (P1767) is detected, go to [AT-138. "Diagnostic Procedure"](#) .

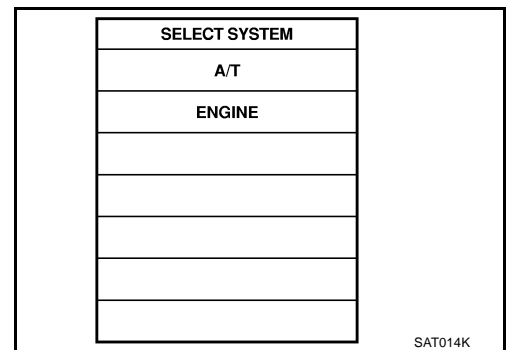

## Diagnostic Procedure

### 1. CHECK INPUT SIGNALS

#### With CONSULT-II

1. Start the engine.
2. Select "ECU INPUT SIGNALS" or "MAIN SIGNALS" in "DATA MONITOR" mode for "A/T" with CONSULT-II.
3. Drive vehicle in the "D" position (2nd ⇒ 3rd gear), and confirm the ON/OFF actuation of the "ATF PRES SW 6".

Item name	Condition	Display value (ON-OFF display)
ATF PRES SW 6	High and low reverse clutch operates. Refer to <a href="#">AT-17</a>	ON
	Other conditions	OFF

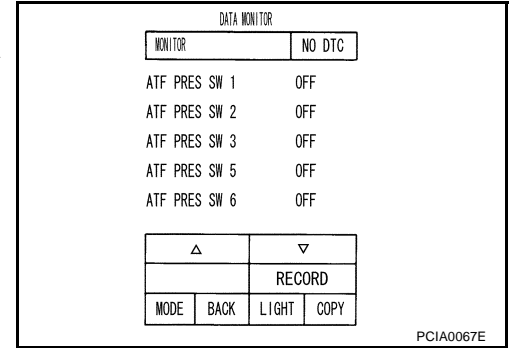

#### OK or NG

- OK >> GO TO 4.
- NG >> GO TO 2.

### 2. CHECK TCM

Perform TCM input/output signal inspection. Refer to [AT-74, "TCM Input/Output Signal Reference Values"](#) .

#### OK or NG

- OK >> GO TO 4.
- NG >> GO TO 3.

### 3. DETECT MALFUNCTIONING ITEM

Check the following items:

- Power supply and ground circuit for TCM.
- A/T assembly harness connector pin terminals for damage or loose connection with harness connector.

#### OK or NG

- OK >> Replace the transmission assembly. Refer to [AT-192, "Removal and Installation"](#) .
- NG >> Repair or replace damaged parts.

### 4. CHECK DTC

Perform DTC Confirmation Procedure.

- Refer to [AT-155, "DTC Confirmation Procedure"](#) .

#### OK or NG

- OK >> **INSPECTION END**
- NG >> GO TO 2.

## CLOSED THROTTLE POSITION AND WIDE OPEN THROTTLE POSITION CIRCUIT

PFP:18002

### Diagnostic Procedure

ACS003R0

#### 1. CHECK CAN COMMUNICATION LINE

Perform the self-diagnosis. Refer to [AT-76, "SELF-DIAGNOSTIC PROCEDURE \(WITH CONSULT-II\)"](#) , [AT-87, "TCM SELF-DIAGNOSTIC PROCEDURE \(NO TOOLS\)"](#) .

Is a malfunction in the CAN communication indicated in the results?

- YES >> Check CAN communication line. Refer to [AT-89, "DTC U1000 CAN COMMUNICATION LINE"](#) .
- NO >> GO TO 2.

#### 2. CHECK THROTTLE POSITION SIGNAL CIRCUIT

##### Ⓜ With CONSULT-II

1. Turn ignition switch "ON". (Do not start engine.)
2. Select "ECU INPUT SIGNALS" in "DATA MONITOR" mode for "A/T" with CONSULT-II.
3. Depress accelerator pedal and read out the value of "CLSD THL POS" and "W/O THL POS".

Accelerator Pedal Operation	Monitor Item	
	CLSD THL POS	W/O THL POS
Released	ON	OFF
Fully depressed	OFF	ON

DATA MONITOR			
MONITOR		NO DTC	
ACCELE POSI	0.0/8		
THROTTLE POSI	0.0/8		
CLSD THL POS	ON		
W/O THL POS	OFF		
BRAKE SW	OFF		
		▽	
RECORD			
MODE	BACK	LIGHT	COPY

PCIA0070E

##### OK or NG

OK >> **INSPECTION END**

NG >> Check the following items. If NG, repair or replace damaged parts.

- Perform the self-diagnosis for "ENGINE" with CONSULT-II. Refer to [EC-103, "CONSULT-II Function"](#) .
- Open circuit or short to ground or short to power in harness or connectors.
- Pin terminals for damage or loose connection with harness connector.

## BRAKE SIGNAL CIRCUIT

PFP:25320

### Diagnostic Procedure

ACS003RP

#### 1. CHECK CAN COMMUNICATION LINE

Perform the self-diagnosis. Refer to [AT-76, "SELF-DIAGNOSTIC PROCEDURE \(WITH CONSULT-II\)"](#) , [AT-87, "TCM SELF-DIAGNOSTIC PROCEDURE \(NO TOOLS\)"](#) .

Is a malfunction in the CAN communication indicated in the results?

- YES >> Check CAN communication line. Refer to [AT-89, "DTC U1000 CAN COMMUNICATION LINE"](#) .  
 NO >> GO TO 2.

#### 2. CHECK STOP LAMP SWITCH CIRCUIT

##### With CONSULT-II

1. Turn ignition switch "ON". (Do not start engine.)
2. Select "ECU INPUT SIGNALS" in "DATA MONITOR" mode for "A/T" with CONSULT-II.
3. Read out ON/OFF switching action of the "BRAKE SW".

OK or NG

- OK >> **INSPECTION END**  
 NG >> GO TO 3.

DATA MONITOR	
MONITOR	NO DTC
ACCELE POSI	0.0/8
THROTTLE POSI	0.0/8
CLSD THL POS	ON
W/O THL POS	OFF
BRAKE SW	OFF
▽	
RECORD	
MODE	BACK
LIGHT	COPY

PCIA0070E

#### 3. CHECK STOP LAMP SWITCH

Check continuity between stop lamp switch harness connector E111 terminals 1 (R/Y) and 2 (P/L).

Condition	Continuity
When brake pedal is depressed	Yes
When brake pedal is released	No

**Check stop lamp switch after adjusting brake pedal — refer to [BR-6, "BRAKE PEDAL"](#) .**

OK or NG

- OK >> **INSPECTION END**  
 NG >> Check the following items. If NG, repair or replace damaged parts.
- Harness for short or open between battery and stop lamp switch.
  - Harness for short or open between stop lamp switch and unified meter and A/C amp.

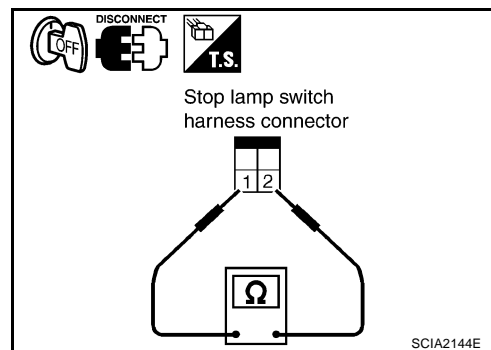

## TROUBLE DIAGNOSIS FOR SYMPTOMS

PFP:00007

### A/T CHECK Indicator Lamp Does Not Come On SYMPTOM:

ACS003S9

A/T CHECK indicator lamp does not come on for about 2 seconds when turning ignition switch to "ON".

### DIAGNOSTIC PROCEDURE

#### 1. CHECK CAN COMMUNICATION LINE

Perform the self-diagnosis. [AT-76, "SELF-DIAGNOSTIC PROCEDURE \(WITH CONSULT-II\)"](#) , [AT-87, "TCM SELF-DIAGNOSTIC PROCEDURE \(NO TOOLS\)"](#) .

Is a malfunction in the CAN communication indicated in the results?

- YES >> Check CAN communication line. Refer to [AT-89, "DTC U1000 CAN COMMUNICATION LINE"](#) .
- NO >> GO TO 2.

#### 2. CHECK TCM POWER SOURCE

1. Disconnect A/T assembly harness connector.
2. Turn ignition switch "ON". (Do not start engine.)
3. Check voltage between A/T assembly harness connector (vehicle side) and ground. Refer to [AT-49, "Wiring Diagram — AT —"](#)

Item	Connector No.	Terminal No. (Wire color)	Voltage
TCM	F6	1 (R/W) - Ground	Battery voltage
		2 (R/W) - Ground	
		6 (Y/R) - Ground	

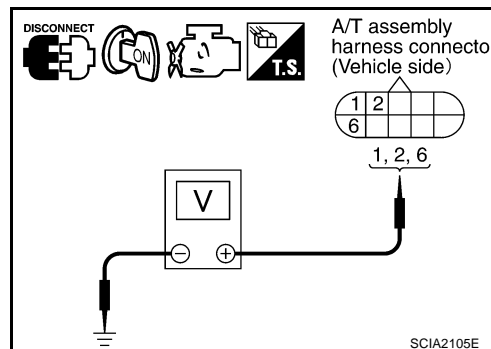

4. Turn ignition switch "OFF".
5. Check voltage between A/T assembly harness connector (vehicle side) and ground. Refer to [AT-49, "Wiring Diagram — AT —"](#) .

Item	Connector No.	Terminal No. (Wire color)	Voltage
TCM	F6	1 (R/W) - Ground	Battery voltage
		2 (R/W) - Ground	
		6 (Y/R) - Ground	0V

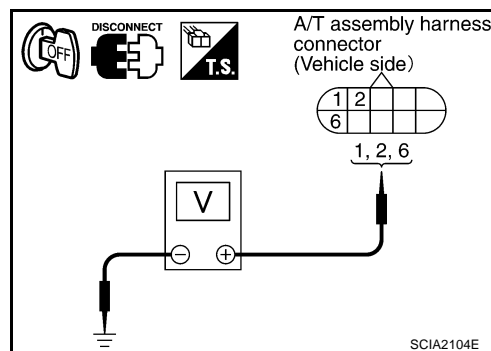

#### OK or NG

- OK >> GO TO 4.
- NG >> GO TO 3.

### 3. DETECT MALFUNCTIONING ITEM

Check the following items:

- Harness for short or open between battery and TCM connector terminals 1, 2
- Harness for short or open between ignition switch and TCM connector terminal 6
- 10A fuse (No. 32, located in the fuse and fusible link box)
- 10A fuse (No. 83, located in the IPDM E/R)
- Ignition switch, Refer to [PG-4, "POWER SUPPLY ROUTING CIRCUIT"](#) .

OK or NG

- OK >> GO TO 4.  
NG >> Repair or replace damaged parts.

### 4. CHECK TCM GROUND CIRCUIT

1. Turn ignition switch "OFF".
2. Disconnect the TCM connector.
3. Check the continuity between A/T assembly harness connector (vehicle side) 5 (B), 10 (B) and ground. Refer to [AT-49, "Wiring Diagram — AT —"](#) .

**Continuity should exist.**

4. If OK, check the harness for short-circuit to ground or the power source.

OK or NG

- OK >> GO TO 5.  
NG >> Repair the open or short circuit in the harness or connector.

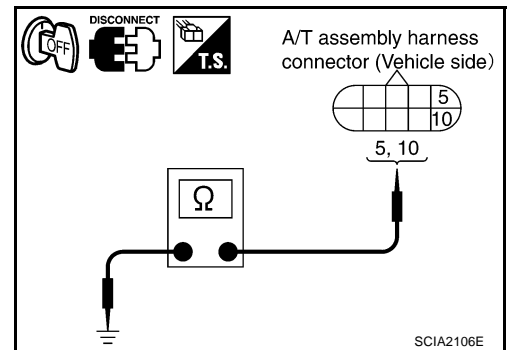

### 5. CHECK A/T CHECK INDICATOR LAMP CIRCUIT

1. Turn ignition switch "OFF".
2. Check the combination meter.  
Refer to [DI-4, "COMBINATION METERS"](#) .

OK or NG

- OK >> **INSPECTION END**  
NG >> Replace the combination meter. Refer to [DI-33, "Removal and Installation for Combination Meter"](#)

## Engine Cannot Be Started In "P" or "N" Position

ACS003SA

**SYMPTOM:**

- Engine cannot be started with selector lever in "P" or "N" position.
- Engine can be started with selector lever in "D" or "R" position.

**DIAGNOSTIC PROCEDURE**

#### 1. CHECK SELF-DIAGNOSIS RESULTS

Perform self-diagnosis. Refer to [AT-76, "SELF-DIAGNOSTIC PROCEDURE \(WITH CONSULT-II\)"](#) , [AT-87, "TCM SELF-DIAGNOSTIC PROCEDURE \(NO TOOLS\)"](#) .

Do the self-diagnosis results indicate PNP switch?

- YES >> Check the malfunctioning system. Refer to [AT-94, "DTC P0705 PARK/NEUTRAL POSITION SWITCH"](#) .  
NO >> GO TO 2.



## 2. CHECK CONTROL LINKAGE

Check the control linkage.

- Refer to [AT-182, "Checking of A/T Position"](#) .

OK or NG

OK >> GO TO 3.

NG >> Adjust control linkage. Refer to [AT-182, "Adjustment of A/T Position"](#) .

## 3. CHECK STARTING SYSTEM

Check the starting system. Refer to [SC-10, "STARTING SYSTEM"](#) .

OK or NG

OK >> **INSPECTION END**

NG >> Repair or replace damaged parts.

### In "P" Position, Vehicle Moves When Pushed SYMPTOM:

ACS003SB

Even though the selector lever is set in the "P" position, the parking mechanism is not actuated, allowing the vehicle to be moved when it is pushed.

### DIAGNOSTIC PROCEDURE

#### 1. CHECK SELF-DIAGNOSIS RESULTS

Perform self-diagnosis. Refer to [AT-76, "SELF-DIAGNOSTIC PROCEDURE \(WITH CONSULT-II\)"](#) , [AT-87, "TCM SELF-DIAGNOSTIC PROCEDURE \(NO TOOLS\)"](#) .

Do the self-diagnosis results indicate PNP switch?

YES >> Check the malfunctioning system. Refer to [AT-94, "DTC P0705 PARK/NEUTRAL POSITION SWITCH"](#) .

NO >> GO TO 2.

## 2. CHECK CONTROL LINKAGE

Check the control linkage.

- Refer to [AT-182, "Checking of A/T Position"](#) .

OK or NG

OK >> GO TO 3.

NG >> Adjust control linkage. Refer to [AT-182, "Adjustment of A/T Position"](#) .

## 3. CHECK SYMPTOM

Check again.

OK or NG

OK >> **INSPECTION END**

NG >> Replace the transmission assembly. Refer to [AT-192, "Removal and Installation"](#) .

## In "N" Position, Vehicle Moves

### SYMPTOM:

Vehicle moves forward or backward when selecting "N" position.

### DIAGNOSTIC PROCEDURE

#### 1. CHECK SELF-DIAGNOSIS RESULTS

Perform self-diagnosis. Refer to [AT-76, "SELF-DIAGNOSTIC PROCEDURE \(WITH CONSULT-II\)"](#) , [AT-87, "TCM SELF-DIAGNOSTIC PROCEDURE \(NO TOOLS\)"](#) .

Do the self-diagnosis results indicate PNP switch?

- YES >> Check the malfunctioning system. Refer to [AT-94, "DTC P0705 PARK/NEUTRAL POSITION SWITCH"](#) .
- NO >> GO TO 2.

#### 2. CHECK CONTROL LINKAGE

Check the control linkage.

- Refer to [AT-182, "Checking of A/T Position"](#) .

OK or NG

- OK >> GO TO 3.
- NG >> Adjust control linkage. Refer to [AT-182, "Adjustment of A/T Position"](#) .

#### 3. CHECK A/T FLUID LEVEL

Check the A/T fluid level. Refer to [AT-10, "Checking A/T Fluid"](#) .

OK or NG

- OK >> GO TO 4.
- NG >> Refill ATF.

#### 4. CHECK SYMPTOM

Check again.

OK or NG

- OK >> **INSPECTION END**
- NG >> GO TO 5.

#### 5. CHECK TCM

Perform TCM input/output signal inspection. Refer to [AT-74, "TCM Input/Output Signal Reference Values"](#) .

OK or NG

- OK >> **INSPECTION END**
- NG >> GO TO 6.

#### 6. DETECT MALFUNCTIONING ITEM

Check the following items:

- Power supply and ground circuit for TCM.
- A/T assembly harness connector pin terminals for damage or loose connection with harness connector.

OK or NG

- OK >> Replace the transmission assembly. Refer to [AT-192, "Removal and Installation"](#) .
- NG >> Repair or replace damaged parts.

## Large Shock (“N” to “D” Position)

ACS003SD

### SYMPTOM:

A noticeable shock occurs when the selector lever is shifted from the “N” to “D” position.

### DIAGNOSTIC PROCEDURE

#### 1. CHECK SELF-DIAGNOSIS RESULTS

Perform self-diagnosis. Refer to [AT-76, "SELF-DIAGNOSTIC PROCEDURE \(WITH CONSULT-II\)"](#) .

Do the self-diagnosis results indicate A/T fluid temperature sensor, engine speed signal, accelerator pedal position sensor, ATF pressure switch 1, front brake solenoid valve, CAN communication line?

YES >> Check the malfunctioning system. Refer to [AT-114, "DTC P1710 A/T FLUID TEMPERATURE SENSOR CIRCUIT"](#) , [AT-98, "DTC P0725 ENGINE SPEED SIGNAL"](#) , [EC-546, "DTC P2122, P2123 APP SENSOR"](#) , [EC-552, "DTC P2127, P2128 APP SENSOR"](#) , [EC-564, "DTC P2138 APP SENSOR"](#) , [AT-149, "DTC P1841 ATF PRESSURE SWITCH 1"](#) , [AT-129, "DTC P1757 FRONT BRAKE SOLENOID VALVE"](#) , [AT-89, "DTC U1000 CAN COMMUNICATION LINE"](#) .

NO >> GO TO 2.

#### 2. ENGINE IDLE SPEED

Check the engine idle speed. Refer to [EC-546, "DTC P2122, P2123 APP SENSOR"](#) , [EC-552, "DTC P2127, P2128 APP SENSOR"](#) , [EC-564, "DTC P2138 APP SENSOR"](#) .

OK or NG

OK >> GO TO 3.

NG >> Repair or replace damaged parts.

#### 3. CHECK CONTROL LINKAGE

Check the control linkage.

- Refer to [AT-182, "Checking of A/T Position"](#) .

OK or NG

OK >> GO TO 4.

NG >> Adjust control linkage. Refer to [AT-182, "Adjustment of A/T Position"](#) .

#### 4. CHECK A/T FLUID LEVEL

Check the A/T fluid level. Refer to [AT-10, "Checking A/T Fluid"](#) .

OK or NG

OK >> GO TO 5.

NG >> Refill ATF.

#### 5. CHECK SYMPTOM

Check again.

OK or NG

OK >> **INSPECTION END**

NG >> GO TO 6.

#### 6. CHECK TCM

Perform TCM input/output signal inspection. Refer to [AT-74, "TCM Input/Output Signal Reference Values"](#) .

OK or NG

OK >> **INSPECTION END**

NG >> GO TO 7.

## 7. DETECT MALFUNCTIONING ITEM

Check the following items:

- Power supply and ground circuit for TCM.
- A/T assembly harness connector pin terminals for damage or loose connection with harness connector.

OK or NG

- OK >> Replace the transmission assembly. Refer to [AT-192, "Removal and Installation"](#) .  
 NG >> Repair or replace damaged parts.

### Vehicle Does Not Creep Backward In “R” Position

ACS003SE

#### SYMPTOM:

The vehicle does not creep in the “R” position. Or an extreme lack of acceleration is observed.

#### DIAGNOSTIC PROCEDURE

### 1. CHECK A/T FLUID LEVEL

Check the A/T fluid level. Refer to [AT-10, "Checking A/T Fluid"](#) .

OK or NG

- OK >> GO TO 2.  
 NG >> Refill ATF.

### 2. CHECK SELF-DIAGNOSIS RESULTS

Perform self-diagnosis. Refer to [AT-76, "SELF-DIAGNOSTIC PROCEDURE \(WITH CONSULT-II\)"](#) .

Do the self-diagnosis results indicate accelerator pedal position sensor, ATF pressure switch 6, high and low reverse clutch solenoid valve, CAN communication line, PNP switch?

- YES >> Check the malfunctioning system. Refer to [EC-546, "DTC P2122, P2123 APP SENSOR"](#) , [EC-552, "DTC P2127, P2128 APP SENSOR"](#) , [EC-564, "DTC P2138 APP SENSOR"](#) , [AT-155, "DTC P1846 ATF PRESSURE SWITCH 6"](#) , [AT-137, "DTC P1767 HIGH AND LOW REVERSE CLUTCH SOLENOID VALVE"](#) , [AT-89, "DTC U1000 CAN COMMUNICATION LINE"](#) , [AT-94, "DTC P0705 PARK/NEUTRAL POSITION SWITCH"](#) .  
 NO >> GO TO 3.

### 3. CHECK LINE PRESSURE

Check the line pressure with the engine idling. Refer to [AT-57, "LINE PRESSURE TEST"](#) .

OK or NG

- OK >> GO TO 4.  
 NG >> Check the line pressure system. Refer to [AT-58, "Judgement of line pressure test"](#) .

### 4. CHECK CONTROL LINKAGE

Check the control linkage.

- Refer to [AT-182, "Checking of A/T Position"](#) .

OK or NG

- OK >> GO TO 5.  
 NG >> Adjust control linkage. Refer to [AT-182, "Adjustment of A/T Position"](#) .

### 5. CHECK SYMPTOM

Check again.

OK or NG

- OK >> **INSPECTION END**  
 NG >> GO TO 6.

## 6. CHECK TCM

Perform TCM input/output signal inspection. Refer to [AT-74, "TCM Input/Output Signal Reference Values"](#) .

OK or NG

- OK >> **INSPECTION END**
- NG >> GO TO 7.

## 7. DETECT MALFUNCTIONING ITEM

Check the following items:

- Power supply and ground circuit for TCM.
- A/T assembly harness connector pin terminals for damage or loose connection with harness connector.

OK or NG

- OK >> Replace the transmission assembly. Refer to [AT-192, "Removal and Installation"](#) .
- NG >> Repair or replace damaged parts.

### Vehicle Does Not Creep Forward In “D” Position

ACS003SF

**SYMPTOM:**

Vehicle does not creep forward when selecting “D” position.

### DIAGNOSTIC PROCEDURE

#### 1. CHECK A/T FLUID LEVEL

Check the A/T fluid level. Refer to [AT-10, "Checking A/T Fluid"](#) .

OK or NG

- OK >> GO TO 2.
- NG >> Refill ATF.

#### 2. CHECK SELF-DIAGNOSIS RESULTS

Perform self-diagnosis. Refer to [AT-76, "SELF-DIAGNOSTIC PROCEDURE \(WITH CONSULT-II\)"](#) , [AT-87, "TCM SELF-DIAGNOSTIC PROCEDURE \(NO TOOLS\)"](#) .

Do the self-diagnosis results indicate accelerator pedal position sensor, CAN communication line, PNP switch?

- YES >> Check the malfunctioning system. Refer to [EC-546, "DTC P2122, P2123 APP SENSOR"](#) , [EC-552, "DTC P2127, P2128 APP SENSOR"](#) , [EC-564, "DTC P2138 APP SENSOR"](#) , [AT-89, "DTC U1000 CAN COMMUNICATION LINE"](#) , [AT-94, "DTC P0705 PARK/NEUTRAL POSITION SWITCH"](#) .
- NO >> GO TO 3.

#### 3. CHECK LINE PRESSURE

Check the line pressure at idle with selector lever in “R” position. Refer to [AT-57, "LINE PRESSURE TEST"](#) .

OK or NG

- OK >> GO TO 4.
- NG >> Check the line pressure solenoid valve. Refer to [AT-104, "DTC P0745 LINE PRESSURE SOLENOID VALVE"](#) .

#### 4. CHECK CONTROL LINKAGE

Check the control linkage.

- Refer to [AT-182, "Checking of A/T Position"](#) .

OK or NG

- OK >> GO TO 5.
- NG >> Adjust control linkage. Refer to [AT-182, "Adjustment of A/T Position"](#) .

---

## 5. CHECK SYMPTOM

---

Check again.

OK or NG

- OK >> **INSPECTION END**
- NG >> GO TO 6.

---

## 6. CHECK TCM

---

Perform TCM input/output signal inspection. Refer to [AT-74, "TCM Input/Output Signal Reference Values"](#) .

OK or NG

- OK >> **INSPECTION END**
- NG >> GO TO 7.

---

## 7. DETECT MALFUNCTIONING ITEM

---

Check the following items:

- Power supply and ground circuit for TCM.
- A/T assembly harness connector pin terminals for damage or loose connection with harness connector.

OK or NG

- OK >> Replace the transmission assembly. Refer to [AT-192, "Removal and Installation"](#) .
- NG >> Repair or replace damaged parts.

### Vehicle Cannot Be Started From D1 SYMPTOM:

ACS003SG

The vehicle cannot be started from D1 .

### DIAGNOSTIC PROCEDURE

---

#### 1. CONFIRM THE SYMPTOM

---

Check if vehicle creeps in "R" position.

OK or NG

- OK >> GO TO 2.
- NG >> Refer to [AT-164, "Vehicle Does Not Creep Backward In "R" Position"](#) .

---

#### 2. CHECK SELF-DIAGNOSIS RESULTS

---

Perform self-diagnosis. refer to [AT-76, "SELF-DIAGNOSTIC PROCEDURE \(WITH CONSULT-II\)"](#) , [AT-87, "TCM SELF-DIAGNOSTIC PROCEDURE \(NO TOOLS\)"](#) .

Is any malfunction detected by self-diagnosis results?

- YES >> Check the malfunctioning system.
- NO >> GO TO 3.

---

#### 3. CHECK LINE PRESSURE

---

Check the line pressure at the engine stall point. Refer to [AT-57, "LINE PRESSURE TEST"](#) .

OK or NG

- OK >> GO TO 4.
- NG >> Check the line pressure system. Refer to [AT-58, "Judgement of line pressure test"](#) .

---

#### 4. CHECK SYMPTOM

---

Check again.

OK or NG

- OK >> **INSPECTION END**
- NG >> GO TO 5.

## 5. CHECK TCM

Perform TCM input/output signal inspection. Refer to [AT-74, "TCM Input/Output Signal Reference Values"](#) .

OK or NG

- OK >> **INSPECTION END**
- NG >> GO TO 6.

## 6. DETECT MALFUNCTIONING ITEM

Check the following items:

- Power supply and ground circuit for TCM.
- A/T assembly harness connector pin terminals for damage or loose connection with harness connector.

OK or NG

- OK >> Replace the transmission assembly. Refer to [AT-192, "Removal and Installation"](#) .
- NG >> Repair or replace damaged parts.

### A/T Does Not Shift: D1 → D2

ACS003SH

#### SYMPTOM:

The vehicle does not shift-up from the D1 to D2 gear at the specified speed.

#### DIAGNOSTIC PROCEDURE

### 1. CONFIRM THE SYMPTOM

Check if vehicle creeps forward in "D" position and vehicle can be started from D1.

OK or NG

- OK >> GO TO 2.
- NG >> Refer to [AT-165, "Vehicle Does Not Creep Forward In "D" Position"](#) , [AT-166, "Vehicle Cannot Be Started From D1"](#) .

### 2. CHECK SELF-DIAGNOSIS RESULTS

Perform self-diagnosis. Refer to [AT-76, "SELF-DIAGNOSTIC PROCEDURE \(WITH CONSULT-II\)"](#)

Do the self-diagnosis results indicate ATF pressure switch 5, direct clutch solenoid valve, accelerator pedal position sensor, vehicle speed sensor A/T (revolution sensor) and vehicle speed sensor MTR?

- YES >> Check the malfunctioning system. Refer to [AT-153, "DTC P1845 ATF PRESSURE SWITCH 5"](#) , [AT-133, "DTC P1762 DIRECT CLUTCH SOLENOID VALVE"](#) , [EC-546, "DTC P2122, P2123 APP SENSOR"](#) , [EC-552, "DTC P2127, P2128 APP SENSOR"](#) , [EC-564, "DTC P2138 APP SENSOR"](#) , [AT-96, "DTC P0720 VEHICLE SPEED SENSOR A/T \(REVOLUTION SENSOR\)"](#) , [AT-118, "DTC P1721 VEHICLE SPEED SENSOR MTR"](#) .
- NO >> GO TO 3.

### 3. CHECK A/T FLUID LEVEL

Check the A/T fluid level. Refer to [AT-10, "Checking A/T Fluid"](#) .

OK or NG

- OK >> GO TO 4.
- NG >> Refill ATF.

### 4. CHECK LINE PRESSURE

Check the line pressure at the engine stall point. Refer to [AT-57, "LINE PRESSURE TEST"](#) .

OK or NG

- OK >> GO TO 5.
- NG >> Check the line pressure system. Refer to [AT-58, "Judgement of line pressure test"](#) .

## 5. CHECK SYMPTOM

Check again.

OK or NG

- OK >> **INSPECTION END**
- NG >> GO TO 6.

## 6. CHECK TCM

Perform TCM input/output signal inspection. Refer to [AT-74, "TCM Input/Output Signal Reference Values"](#) .

OK or NG

- OK >> **INSPECTION END**
- NG >> GO TO 7.

## 7. DETECT MALFUNCTIONING ITEM

Check the following items:

- Power supply and ground circuit for TCM.
- A/T assembly harness connector pin terminals for damage or loose connection with harness connector.

OK or NG

- OK >> Replace the transmission assembly. Refer to [AT-192, "Removal and Installation"](#) .
- NG >> Repair or replace damaged parts.

### **A/T Does Not Shift: D2 → D3** **SYMPTOM:**

ACS003SI

The vehicle does not shift-up from D2 to D3 gear at the specified speed.

### **DIAGNOSTIC PROCEDURE**

#### **1. CONFIRM THE SYMPTOM**

Check if vehicle creeps forward in "D" position" and vehicle can be started from D1.

OK or NG

- OK >> GO TO 2.
- NG >> Refer to [AT-165, "Vehicle Does Not Creep Forward In "D" Position"](#) ,[AT-166, "Vehicle Cannot Be Started From D1"](#) .

#### **2. CHECK SELF-DIAGNOSIS RESULTS**

Perform self-diagnosis. Refer to [AT-76, "SELF-DIAGNOSTIC PROCEDURE \(WITH CONSULT-II\)"](#) .

Do the self-diagnosis results indicate ATF pressure switch 6, high and low reverse clutch solenoid valve, accelerator pedal position sensor, vehicle speed sensor A/T (revolution sensor) and vehicle speed sensor MTR?

- YES >> Check the malfunctioning system. Refer to [AT-155, "DTC P1846 ATF PRESSURE SWITCH 6"](#) , [AT-137, "DTC P1767 HIGH AND LOW REVERSE CLUTCH SOLENOID VALVE"](#) , [EC-546, "DTC P2122, P2123 APP SENSOR"](#) , [EC-552, "DTC P2127, P2128 APP SENSOR"](#) , [EC-564, "DTC P2138 APP SENSOR"](#) , [AT-96, "DTC P0720 VEHICLE SPEED SENSOR A/T \(REVOLUTION SENSOR\)"](#) , [AT-118, "DTC P1721 VEHICLE SPEED SENSOR MTR"](#) .
- NO >> GO TO 3.

#### **3. CHECK A/T FLUID LEVEL**

Check the A/T fluid level. Refer to [AT-10, "Checking A/T Fluid"](#) .

OK or NG

- OK >> GO TO 4.
- NG >> Refill ATF.



## 4. CHECK LINE PRESSURE

Check the line pressure at the engine stall point. Refer to [AT-57, "LINE PRESSURE TEST"](#) .

OK or NG

OK >> GO TO 5.

NG >> Check the line pressure system. Refer to [AT-58, "Judgement of line pressure test"](#) .

## 5. CHECK SYMPTOM

Check again.

OK or NG

OK >> **INSPECTION END**

NG >> GO TO 6.

## 6. CHECK TCM

Perform TCM input/output signal inspection. Refer to [AT-74, "TCM Input/Output Signal Reference Values"](#) .

OK or NG

OK >> **INSPECTION END**

NG >> GO TO 7.

## 7. DETECT MALFUNCTIONING ITEM

Check the following items:

- Power supply and ground circuit for TCM.
- A/T assembly harness connector pin terminals for damage or loose connection with harness connector.

OK or NG

OK >> Replace the transmission assembly. Refer to [AT-192, "Removal and Installation"](#) .

NG >> Repair or replace damaged parts.

### **A/T Does Not Shift: D3 → D4**

ACS003SJ

#### **SYMPTOM:**

- The vehicle does not shift-up from the D3 to D4 gear at the specified speed.
- The vehicle does not shift-up from the D3 to D4 gear unless A/T is warmed up.

#### **DIAGNOSTIC PROCEDURE**

### 1. CONFIRM THE SYMPTOM

Check if vehicle creeps forward in "D" position and vehicle can be started from D1.

OK or NG

OK >> GO TO 2.

NG >> Refer to [AT-165, "Vehicle Does Not Creep Forward In "D" Position"](#) , [AT-166, "Vehicle Cannot Be Started From D1"](#) .

### 2. CHECK SELF-DIAGNOSIS RESULTS

Perform self-diagnosis. Refer to [AT-76, "SELF-DIAGNOSTIC PROCEDURE \(WITH CONSULT-II\)"](#) .

Do the self-diagnosis results indicate ATF pressure switch 1, ATF pressure switch 3, front brake solenoid valve, input clutch solenoid valve, accelerator pedal position sensor, vehicle speed sensor A/T (revolution sensor) and vehicle speed sensor MTR?

YES >> Check the malfunctioning system. Refer to [AT-149, "DTC P1841 ATF PRESSURE SWITCH 1"](#) , [AT-151, "DTC P1843 ATF PRESSURE SWITCH 3"](#) , [AT-129, "DTC P1757 FRONT BRAKE SOLENOID VALVE"](#) , [AT-125, "DTC P1752 INPUT CLUTCH SOLENOID VALVE"](#) , [EC-546, "DTC P2122, P2123 APP SENSOR"](#) , [EC-552, "DTC P2127, P2128 APP SENSOR"](#) , [EC-564, "DTC P2138 APP SENSOR"](#) , [AT-96, "DTC P0720 VEHICLE SPEED SENSOR A/T \(REVOLUTION SENSOR\)"](#) , [AT-118, "DTC P1721 VEHICLE SPEED SENSOR MTR"](#) .

NO >> GO TO 3.

---

## 3. CHECK A/T FLUID LEVEL

---

Check the A/T fluid level. Refer to [AT-10, "Checking A/T Fluid"](#) .

OK or NG

- OK >> GO TO 4.
- NG >> Refill ATF.

---

## 4. CHECK LINE PRESSURE

---

Check the line pressure at the engine stall point. Refer to [AT-57, "LINE PRESSURE TEST"](#) .

OK or NG

- OK >> GO TO 5.
- NG >> Check the line pressure system. Refer to [AT-58, "Judgement of line pressure test"](#) .

---

## 5. CHECK SYMPTOM

---

Check again.

OK or NG

- OK >> **INSPECTION END**
- NG >> GO TO 6.

---

## 6. CHECK TCM

---

Perform TCM input/output signal inspection. Refer to [AT-74, "TCM Input/Output Signal Reference Values"](#) .

OK or NG

- OK >> **INSPECTION END**
- NG >> GO TO 7.

---

## 7. DETECT MALFUNCTIONING ITEM

---

Check the following items:

- Power supply and ground circuit for TCM.
- A/T assembly harness connector pin terminals for damage or loose connection with harness connector.

OK or NG

- OK >> Replace the transmission assembly. Refer to [AT-192, "Removal and Installation"](#) .
- NG >> Repair or replace damaged parts.

### **A/T Does Not Shift: D4 → D5**

#### **SYMPTOM:**

- The vehicle does not shift-up from the D4 to D5 gear at the specified speed.
- The vehicle does not shift-up from the D4 to D5 gear unless A/T is warmed up.

#### **DIAGNOSTIC PROCEDURE**

---

### 1. CONFIRM THE SYMPTOM

---

Check if vehicle creeps forward in "D" position and vehicle can be started from D1.

OK or NG

- OK >> GO TO 2.
- NG >> Refer to [AT-165, "Vehicle Does Not Creep Forward In "D" Position"](#) , [AT-166, "Vehicle Cannot Be Started From D1"](#) .

ACS003SK

## 2. CHECK SELF-DIAGNOSIS RESULTS

Perform self-diagnosis. Refer to [AT-76, "SELF-DIAGNOSTIC PROCEDURE \(WITH CONSULT-II\)"](#) .

Do the self-diagnosis results indicate ATF pressure switch 1, ATF pressure switch 5, front brake solenoid valve, direct clutch solenoid valve, accelerator pedal position sensor, turbine revolution sensor, vehicle speed sensor A/T (revolution sensor) and vehicle speed sensor MTR?

YES >> Check the malfunctioning system. Refer to [AT-149, "DTC P1841 ATF PRESSURE SWITCH 1"](#) , [AT-153, "DTC P1845 ATF PRESSURE SWITCH 5"](#) , [AT-129, "DTC P1757 FRONT BRAKE SOLENOID VALVE"](#) , [AT-133, "DTC P1762 DIRECT CLUTCH SOLENOID VALVE"](#) , [EC-546, "DTC P2122, P2123 APP SENSOR"](#) , [EC-552, "DTC P2127, P2128 APP SENSOR"](#) , [EC-564, "DTC P2138 APP SENSOR"](#) , [AT-116, "DTC P1716 TURBINE REVOLUTION SENSOR"](#) , [AT-96, "DTC P0720 VEHICLE SPEED SENSOR A/T \(REVOLUTION SENSOR\)"](#) , [AT-118, "DTC P1721 VEHICLE SPEED SENSOR MTR"](#) .

NO >> GO TO 3.

## 3. CHECK A/T FLUID LEVEL

Check the A/T fluid level. Refer to [AT-10, "Checking A/T Fluid"](#) .

OK or NG

OK >> GO TO 4.

NG >> Refill ATF.

## 4. CHECK LINE PRESSURE

Check the line pressure at the engine stall point. Refer to [AT-57, "LINE PRESSURE TEST"](#) .

OK or NG

OK >> GO TO 5.

NG >> Check the line pressure system. Refer to [AT-58, "Judgement of line pressure test"](#) .

## 5. CHECK SYMPTOM

Check again.

OK or NG

OK >> **INSPECTION END**

NG >> GO TO 6.

## 6. CHECK TCM

Perform TCM input/output signal inspection. Refer to [AT-74, "TCM Input/Output Signal Reference Values"](#) .

OK or NG

OK >> **INSPECTION END**

NG >> GO TO 7.

## 7. DETECT MALFUNCTIONING ITEM

Check the following items:

- Power supply and ground circuit for TCM.
- A/T assembly harness connector pin terminals for damage or loose connection with harness connector.

OK or NG

OK >> Replace the transmission assembly. Refer to [AT-192, "Removal and Installation"](#) .

NG >> Repair or replace damaged parts.

## A/T Does Not Perform Lock-up

ACS003SL

### SYMPTOM:

A/T does not perform lock-up at the specified speed.

### DIAGNOSTIC PROCEDURE

#### 1. CHECK SELF-DIAGNOSIS RESULTS

Perform self-diagnosis. Refer to [AT-76, "SELF-DIAGNOSTIC PROCEDURE \(WITH CONSULT-II\)"](#) , [AT-87, "TCM SELF-DIAGNOSTIC PROCEDURE \(NO TOOLS\)"](#) .

Do the self-diagnosis results indicate torque converter clutch solenoid valve, engine speed signal, turbine revolution sensor, accelerator pedal position sensor, CAN communication?

YES >> Check the malfunctioning system. Refer to [AT-100, "DTC P0740 TORQUE CONVERTER CLUTCH SOLENOID VALVE"](#) , [AT-98, "DTC P0725 ENGINE SPEED SIGNAL"](#) , [AT-116, "DTC P1716 TURBINE REVOLUTION SENSOR"](#) , [EC-546, "DTC P2122, P2123 APP SENSOR"](#) , [EC-552, "DTC P2127, P2128 APP SENSOR"](#) , [EC-564, "DTC P2138 APP SENSOR"](#) , [AT-89, "DTC U1000 CAN COMMUNICATION LINE"](#) .

NO >> GO TO 2.

#### 2. CHECK A/T FLUID LEVEL

Check the A/T fluid level. Refer to [AT-10, "Checking A/T Fluid"](#) .

OK or NG

OK >> GO TO 3.  
NG >> Refill ATF.

#### 3. CHECK LINE PRESSURE

Check the line pressure at the engine stall point. Refer to [AT-57, "LINE PRESSURE TEST"](#) .

OK or NG

OK >> GO TO 4.  
NG >> Check the line pressure system. Refer to [AT-58, "Judgement of line pressure test"](#) .

#### 4. CHECK SYMPTOM

Check again.

OK or NG

OK >> **INSPECTION END**  
NG >> GO TO 5.

#### 5. CHECK TCM

Perform TCM input/output signal inspection. Refer to [AT-74, "TCM Input/Output Signal Reference Values"](#) .

OK or NG

OK >> **INSPECTION END**  
NG >> GO TO 6.

#### 6. DETECT MALFUNCTIONING ITEM

Check the following items:

- Power supply and ground circuit for TCM.
- A/T assembly harness connector pin terminals for damage or loose connection with harness connector.

OK or NG

OK >> Replace the transmission assembly. Refer to [AT-192, "Removal and Installation"](#) .  
NG >> Repair or replace damaged parts.

## A/T Does Not Hold Lock-up Condition

ACS003SM

### SYMPTOM:

The lock-up condition cannot be maintained for more than 30 seconds.

### DIAGNOSTIC PROCEDURE

#### 1. CHECK SELF-DIAGNOSIS RESULTS

Perform self-diagnosis. Refer to [AT-76, "SELF-DIAGNOSTIC PROCEDURE \(WITH CONSULT-II\)"](#) , [AT-87, "TCM SELF-DIAGNOSTIC PROCEDURE \(NO TOOLS\)"](#) .

Do the self-diagnosis results indicate torque converter clutch solenoid valve, engine speed signal, turbine revolution sensor, CAN communication?

YES >> Check the malfunctioning system. Refer to [AT-100, "DTC P0740 TORQUE CONVERTER CLUTCH SOLENOID VALVE"](#) , [AT-98, "DTC P0725 ENGINE SPEED SIGNAL"](#) , [AT-116, "DTC P1716 TURBINE REVOLUTION SENSOR"](#) , [AT-89, "DTC U1000 CAN COMMUNICATION LINE"](#)

NO >> GO TO 2.

#### 2. CHECK SYMPTOM

Check again.

OK or NG

OK >> **INSPECTION END**

NG >> GO TO 3.

#### 3. CHECK TCM

Perform TCM input/output signal inspection. Refer to [AT-74, "TCM Input/Output Signal Reference Values"](#) .

OK or NG

OK >> **INSPECTION END**

NG >> GO TO 4.

#### 4. DETECT MALFUNCTIONING ITEM

Check the following items:

- Power supply and ground circuit for TCM.
- A/T assembly harness connector pin terminals for damage or loose connection with harness connector.

OK or NG

OK >> Replace the transmission assembly. Refer to [AT-192, "Removal and Installation"](#) .

NG >> Repair or replace damaged parts.

## Lock-up Is Not Released

ACS003SN

### SYMPTOM:

The lock-up condition cannot be cancelled.

### DIAGNOSTIC PROCEDURE

#### 1. CHECK SELF-DIAGNOSIS RESULTS

Perform self-diagnosis. Refer to [AT-76, "SELF-DIAGNOSTIC PROCEDURE \(WITH CONSULT-II\)"](#) , [AT-87, "TCM SELF-DIAGNOSTIC PROCEDURE \(NO TOOLS\)"](#) .

Do the self-diagnosis results indicate torque converter clutch solenoid valve, engine speed signal, turbine revolution sensor, CAN communication?

YES >> Check the malfunctioning system. Refer to [AT-100, "DTC P0740 TORQUE CONVERTER CLUTCH SOLENOID VALVE"](#) , [AT-98, "DTC P0725 ENGINE SPEED SIGNAL"](#) , [AT-116, "DTC P1716 TURBINE REVOLUTION SENSOR"](#) , [AT-89, "DTC U1000 CAN COMMUNICATION LINE"](#)

NO >> GO TO 2.

## 2. CHECK SYMPTOM

Check again.

OK or NG

OK >> **INSPECTION END**  
 NG >> GO TO 3.

## 3. CHECK TCM

Perform TCM input/output signal inspection. Refer to [AT-74, "TCM Input/Output Signal Reference Values"](#) .

OK or NG

OK >> **INSPECTION END**  
 NG >> GO TO 4.

## 4. DETECT MALFUNCTIONING ITEM

Check the following items:

- Power supply and ground circuit for TCM.
- A/T assembly harness connector pin terminals for damage or loose connection with harness connector.

OK or NG

OK >> Replace the transmission assembly. Refer to [AT-192, "Removal and Installation"](#) .  
 NG >> Repair or replace damaged parts.

### Engine Speed Does Not Return To Idle

ACS003SO

#### SYMPTOM:

When a shift-down is performed, the engine speed does not smoothly return to the idling speed.

#### DIAGNOSTIC PROCEDURE

### 1. CHECK A/T FLUID LEVEL

Check the A/T fluid level. Refer to [AT-10, "Checking A/T Fluid"](#) .

OK or NG

OK >> GO TO 2.  
 NG >> Refill ATF.

### 2. CHECK SELF-DIAGNOSIS RESULTS

Perform self-diagnosis. Refer to [AT-76, "SELF-DIAGNOSTIC PROCEDURE \(WITH CONSULT-II\)"](#) .

Do the self-diagnosis results indicate front brake solenoid valve, direct clutch solenoid valve, ATF pressure switch 1, ATF pressure switch 5, accelerator pedal position sensor, vehicle speed sensor A/T (revolution sensor) and vehicle speed sensor MTR?

YES >> Check the malfunctioning system. Refer to [AT-129, "DTC P1757 FRONT BRAKE SOLENOID VALVE"](#) , [AT-133, "DTC P1762 DIRECT CLUTCH SOLENOID VALVE"](#) , [AT-149, "DTC P1841 ATF PRESSURE SWITCH 1"](#) , [AT-153, "DTC P1845 ATF PRESSURE SWITCH 5"](#) , [EC-546, "DTC P2122, P2123 APP SENSOR"](#) , [EC-552, "DTC P2127, P2128 APP SENSOR"](#) , [EC-564, "DTC P2138 APP SENSOR"](#) , [AT-96, "DTC P0720 VEHICLE SPEED SENSOR A/T \(REVOLUTION SENSOR\)"](#) , [AT-118, "DTC P1721 VEHICLE SPEED SENSOR MTR"](#) .

NO >> GO TO 3.

### 3. CHECK SYMPTOM

Check again.

OK or NG

OK >> **INSPECTION END**  
 NG >> GO TO 4.

## 4. CHECK TCM

Perform TCM input/output signal inspection. Refer to [AT-74, "TCM Input/Output Signal Reference Values"](#) .

OK or NG

- OK >> **INSPECTION END**
- NG >> GO TO 5.

## 5. DETECT MALFUNCTIONING ITEM

Check the following items:

- Power supply and ground circuit for TCM.
- A/T assembly harness connector pin terminals for damage or loose connection with harness connector.

OK or NG

- OK >> Replace the transmission assembly. Refer to [AT-192, "Removal and Installation"](#) .
- NG >> Repair or replace damaged parts.

### Cannot Be changed to Manual Mode SYMPTOM:

ACS003SP

**Does not change to manual mode when manual shift gate is used.**

### DIAGNOSTIC PROCEDURE

#### 1. MANUAL MODE SWITCH

Check the manual mode switch. Refer to [AT-145, "DTC P1815 MANUAL MODE SWITCH"](#) .

OK or NG

- OK >> GO TO 2.
- NG >> Repair or replace damaged parts.

#### 2. CHECK SELF-DIAGNOSIS RESULTS

Perform self-diagnosis. Refer to [AT-76, "SELF-DIAGNOSTIC PROCEDURE \(WITH CONSULT-II\)"](#) .

Do the self-diagnosis results indicate turbine revolution sensor?

- YES >> Check the malfunctioning system. Refer to [AT-116, "DTC P1716 TURBINE REVOLUTION SENSOR"](#) .
- NO >> **INSPECTION END**

### A/T Does Not Shift: 5th gear → 4th gear

ACS003SQ

**SYMPTOM:**

**When shifted from M5 to M4 position in manual mode, does not downshift from 5th to 4th gears.**

### DIAGNOSTIC PROCEDURE

#### 1. CHECK SELF-DIAGNOSIS RESULTS

Perform self-diagnosis. Refer to [AT-76, "SELF-DIAGNOSTIC PROCEDURE \(WITH CONSULT-II\)"](#) .

Do the self-diagnosis results indicate PNP switch, ATF pressure switch 1?

- YES >> Check the malfunctioning system. Refer to [AT-94, "DTC P0705 PARK/NEUTRAL POSITION SWITCH"](#) , [AT-149, "DTC P1841 ATF PRESSURE SWITCH 1"](#) .
- NO >> GO TO 2.

#### 2. CHECK A/T FLUID LEVEL

Check the A/T fluid level. Refer to [AT-10, "Checking A/T Fluid"](#) .

OK or NG

- OK >> GO TO 3.
- NG >> Refill ATF.

### 3. CHECK CONTROL LINKAGE

Check the control linkage.

- Refer to [AT-182, "Checking of A/T Position"](#) .

OK or NG

OK >> GO TO 4.

NG >> Adjust control linkage. Refer to [AT-182, "Adjustment of A/T Position"](#) .

### 4. MANUAL MODE SWITCH

Check the manual mode switch. Refer to [AT-145, "DTC P1815 MANUAL MODE SWITCH"](#) .

OK or NG

OK >> GO TO 5.

NG >> Repair or replace damaged parts.

### 5. CHECK SYMPTOM

Check again.

OK or NG

OK >> **INSPECTION END**

NG >> GO TO 6.

### 6. CHECK TCM

Perform TCM input/output signal inspection. Refer to [AT-74, "TCM Input/Output Signal Reference Values"](#) .

OK or NG

OK >> **INSPECTION END**

NG >> GO TO 7.

### 7. DETECT MALFUNCTIONING ITEM

Check the following items:

- Power supply and ground circuit for TCM.
- A/T assembly harness connector pin terminals for damage or loose connection with harness connector.

OK or NG

OK >> Replace the transmission assembly. Refer to [AT-192, "Removal and Installation"](#) .

NG >> Repair or replace damaged parts.

### A/T Does Not Shift: 4th gear → 3rd gear

ACS003SR

**SYMPTOM:**

When shifted from M4 to M3 position in manual mode, does not downshift from 4th to 3rd gears.

### DIAGNOSTIC PROCEDURE

#### 1. CHECK SELF-DIAGNOSIS RESULTS

Perform self-diagnosis. Refer to [AT-76, "SELF-DIAGNOSTIC PROCEDURE \(WITH CONSULT-II\)"](#) .

Do the self-diagnosis results indicate PNP switch, ATF pressure switch 1, ATF pressure switch 3?

YES >> Check the malfunctioning system. Refer to [AT-94, "DTC P0705 PARK/NEUTRAL POSITION SWITCH"](#) , [AT-149, "DTC P1841 ATF PRESSURE SWITCH 1"](#) , [AT-151, "DTC P1843 ATF PRESSURE SWITCH 3"](#) .

NO >> GO TO 2.



## 2. CHECK A/T FLUID LEVEL

Check the A/T fluid level. Refer to [AT-10, "Checking A/T Fluid"](#) .

OK or NG

- OK >> GO TO 3.
- NG >> Refill ATF.

## 3. CHECK CONTROL LINKAGE

Check the control linkage.

- Refer to [AT-182, "Checking of A/T Position"](#) .

OK or NG

- OK >> GO TO 4.
- NG >> Adjust control linkage. Refer to [AT-182, "Adjustment of A/T Position"](#) .

## 4. MANUAL MODE SWITCH

Check the manual mode switch. Refer to [AT-145, "DTC P1815 MANUAL MODE SWITCH"](#) .

OK or NG

- OK >> GO TO 5.
- NG >> Repair or replace damaged parts.

## 5. CHECK SYMPTOM

Check again.

OK or NG

- OK >> **INSPECTION END**
- NG >> GO TO 6.

## 6. CHECK TCM

Perform TCM input/output signal inspection. Refer to [AT-74, "TCM Input/Output Signal Reference Values"](#) .

OK or NG

- OK >> **INSPECTION END**
- NG >> GO TO 7.

## 7. DETECT MALFUNCTIONING ITEM

Check the following items:

- Power supply and ground circuit for TCM.
- A/T assembly harness connector pin terminals for damage or loose connection with harness connector.

OK or NG

- OK >> Replace the transmission assembly. Refer to [AT-192, "Removal and Installation"](#) .
- NG >> Repair or replace damaged parts.

### **A/T Does Not Shift: 3rd gear → 2nd gear**

ACS003SS

#### **SYMPTOM:**

**When shifted from M3 to M2 position in manual mode, does not downshift from 3rd to 2nd gears.**

#### **DIAGNOSTIC PROCEDURE**

### 1. CHECK SELF-DIAGNOSIS RESULTS

Perform self-diagnosis. Refer to [AT-76, "SELF-DIAGNOSTIC PROCEDURE \(WITH CONSULT-II\)"](#) .

Do the self-diagnosis results indicate PNP switch, ATF pressure switch 6?

- YES >> Check the malfunctioning system. Refer to [AT-94, "DTC P0705 PARK/NEUTRAL POSITION SWITCH"](#) , [AT-155, "DTC P1846 ATF PRESSURE SWITCH 6"](#) .
- NO >> GO TO 2.

## 2. CHECK A/T FLUID LEVEL

Check the A/T fluid level. Refer to [AT-10, "Checking A/T Fluid"](#) .

OK or NG

- OK >> GO TO 3.
- NG >> Refill ATF.

## 3. CHECK CONTROL LINKAGE

Check the control linkage.

- Refer to [AT-182, "Checking of A/T Position"](#) .

OK or NG

- OK >> GO TO 4.
- NG >> Adjust control linkage. Refer to [AT-182, "Adjustment of A/T Position"](#) .

## 4. MANUAL MODE SWITCH

Check the manual mode switch. Refer to [AT-145, "DTC P1815 MANUAL MODE SWITCH"](#) .

OK or NG

- OK >> GO TO 5.
- NG >> Repair or replace damaged parts.

## 5. CHECK SYMPTOM

Check again.

OK or NG

- OK >> **INSPECTION END**
- NG >> GO TO 6.

## 6. CHECK TCM

Perform TCM input/output signal inspection. Refer to [AT-74, "TCM Input/Output Signal Reference Values"](#) .

OK or NG

- OK >> **INSPECTION END**
- NG >> GO TO 7.

## 7. DETECT MALFUNCTIONING ITEM

Check the following items:

- Power supply and ground circuit for TCM.
- A/T assembly harness connector pin terminals for damage or loose connection with harness connector.

OK or NG

- OK >> Replace the transmission assembly. Refer to [AT-192, "Removal and Installation"](#) .
- NG >> Repair or replace damaged parts.

### **A/T Does Not Shift: 2nd gear → 1st gear**

#### **SYMPTOM:**

**When shifted from M2 to M1 position in manual mode, does not downshift from 2nd to 1st gears.**

#### **DIAGNOSTIC PROCEDURE**

### **1. CHECK SELF-DIAGNOSIS RESULTS**

Perform self-diagnosis. Refer to [AT-76, "SELF-DIAGNOSTIC PROCEDURE \(WITH CONSULT-II\)"](#) .

Do the self-diagnosis results indicate PNP switch, ATF pressure switch 5?

- YES >> Check the malfunctioning system. Refer to [AT-94, "DTC P0705 PARK/NEUTRAL POSITION SWITCH"](#) , [AT-153, "DTC P1845 ATF PRESSURE SWITCH 5"](#) .
- NO >> GO TO 2.

ACS003ST

## 2. CHECK A/T FLUID LEVEL

Check the A/T fluid level. Refer to [AT-10, "Checking A/T Fluid"](#) .

OK or NG

- OK >> GO TO 3.
- NG >> Refill ATF.

## 3. CHECK CONTROL LINKAGE

Check the control linkage.

- Refer to [AT-182, "Checking of A/T Position"](#) .

OK or NG

- OK >> GO TO 4.
- NG >> Adjust control linkage. Refer to [AT-182, "Adjustment of A/T Position"](#) .

## 4. MANUAL MODE SWITCH

Check the manual mode switch. Refer to [AT-145, "DTC P1815 MANUAL MODE SWITCH"](#)

OK or NG

- OK >> GO TO 5.
- NG >> Repair or replace damaged parts.

## 5. CHECK SYMPTOM

Check again.

OK or NG

- OK >> **INSPECTION END**
- NG >> GO TO 6.

## 6. CHECK TCM

Perform TCM input/output signal inspection. Refer to [AT-74, "TCM Input/Output Signal Reference Values"](#) .

OK or NG

- OK >> **INSPECTION END**
- NG >> GO TO 7.

## 7. DETECT MALFUNCTIONING ITEM

Check the following items:

- Power supply and ground circuit for TCM.
- A/T assembly harness connector pin terminals for damage or loose connection with harness connector.

OK or NG

- OK >> Replace the transmission assembly. Refer to [AT-192, "Removal and Installation"](#) .
- NG >> Repair or replace damaged parts.

## Vehicle Does Not Decelerate By Engine Brake

ACS003SU

### SYMPTOM:

No engine brake is applied when the gear is shifted from the M2 to M1.

### DIAGNOSTIC PROCEDURE

#### 1. CHECK SELF-DIAGNOSIS RESULTS

Perform self-diagnosis. [AT-76, "SELF-DIAGNOSTIC PROCEDURE \(WITH CONSULT-II\)"](#) .

Do the self-diagnosis results indicate PNP switch, ATF pressure switch 5?

- YES >> Check the malfunctioning system. Refer to [AT-94, "DTC P0705 PARK/NEUTRAL POSITION SWITCH"](#) , [AT-153, "DTC P1845 ATF PRESSURE SWITCH 5"](#) .
- NO >> GO TO 2.

---

## 2. CHECK A/T FLUID LEVEL

---

Check the A/T fluid level. Refer to [AT-10, "Checking A/T Fluid"](#) .

OK or NG

- OK >> GO TO 3.
- NG >> Refill ATF.

---

## 3. CHECK CONTROL LINKAGE

---

Check the control linkage.

- Refer to [AT-182, "Checking of A/T Position"](#) .

OK or NG

- OK >> GO TO 4.
- NG >> Adjust control linkage. Refer to [AT-182, "Adjustment of A/T Position"](#) .

---

## 4. MANUAL MODE SWITCH

---

Check the manual mode switch. Refer to [AT-145, "DTC P1815 MANUAL MODE SWITCH"](#)

OK or NG

- OK >> GO TO 5.
- NG >> Repair or replace damaged parts.

---

## 5. CHECK SYMPTOM

---

Check again.

OK or NG

- OK >> **INSPECTION END**
- NG >> GO TO 6.

---

## 6. CHECK TCM

---

Perform TCM input/output signal inspection. Refer to [AT-74, "TCM Input/Output Signal Reference Values"](#) .

OK or NG

- OK >> **INSPECTION END**
- NG >> GO TO 7.

---

## 7. DETECT MALFUNCTIONING ITEM

---

Check the following items:

- Power supply and ground circuit for TCM.
- A/T assembly harness connector pin terminals for damage or loose connection with harness connector.

OK or NG

- OK >> Replace the transmission assembly. Refer to [AT-192, "Removal and Installation"](#) .
- NG >> Repair or replace damaged parts.

**SHIFT CONTROL SYSTEM**

PFP:34901

**Control Device Removal and Installation**

ACS00006

A  
B  
AT  
D  
E  
F  
G  
H  
I  
J  
K  
L  
M

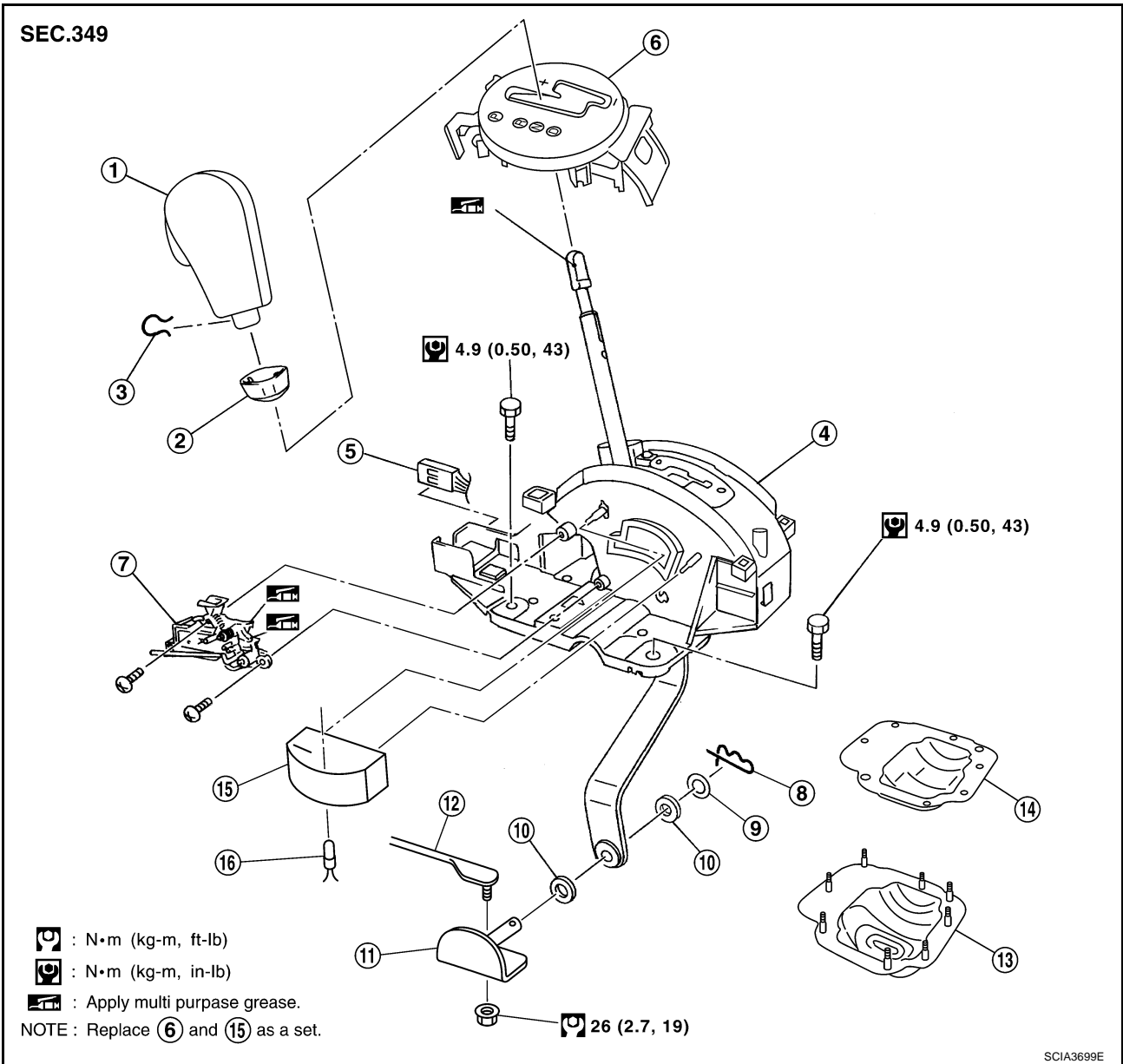

- |  |                                 |                             |
|--|---------------------------------|-----------------------------|
| 1. Selector lever knob                                   | 2. Knob cover                   | 3. Lock pin                 |
| 4. Control device assembly                               | 5. A/T device harness connector | 6. Position indicator plate |
| 7. Shift lock solenoid and park position switch assembly | 8. Snap pin                     | 9. Conical washer           |
| 10. Plain washer   | 11. Bracket                     | 12. Control rod             |
| 13. Dust cover   | 14. Dust cover plate            | 15. Bulb case               |
| 16. Position lamp  |                                 |                             |

## REMOVAL

1. Disconnect lower lever of control device and control rod.
2. Remove knob cover below selector lever downward.
3. Pull lock pin out of selector lever knob.
4. Remove selector lever knob.
5. Remove console finisher (A/T ring) and console finisher.
  - Refer to [IP-10, "INSTRUMENT PANEL ASSEMBLY"](#) .
6. Remove center console.
  - Refer to [IP-10, "INSTRUMENT PANEL ASSEMBLY"](#) .
7. Remove key interlock cable from control device.
  - Refer to [AT-188, "KEY INTERLOCK CABLE"](#) .
8. Disconnect A/T device harness connector.
9. Remove control device assembly.

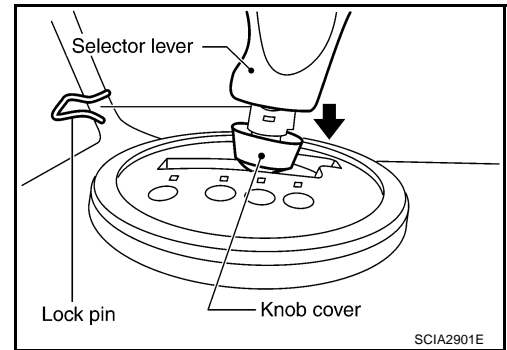

### CAUTION:

**Do not impact, or damage propeller shaft tube.**

## INSTALLATION

Install in reverse order of removal. Be careful of the following:

- After installation is completed, adjust and check A/T position.

## Adjustment of A/T Position

1. Loosen nut of control rod.
2. Place PNP switch and selector lever in "P" position.
3. While pressing lower lever toward rear of vehicle (in P-position direction), tighten nut to specified torque.

: **26 N·m (2.7 kg·m, 19 ft·lb)**

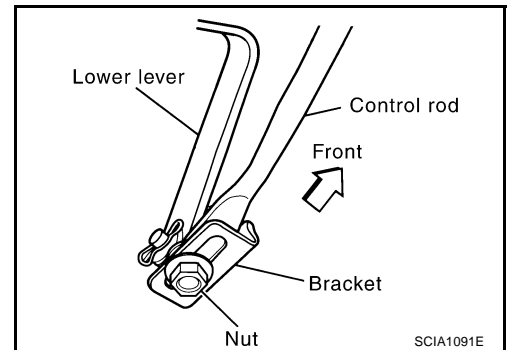

## Checking of A/T Position

1. Place selector lever in "P" position, and turn ignition switch ON (engine stop).
2. Check that selector lever can be shifted to other than "P" position when brake pedal is depressed. Also check that selector lever can be shifted from "P" position only when brake pedal is depressed.
3. Move the selector lever and check for excessive effort, sticking, noise or rattle.
4. Confirm the selector lever stops at each position with the feel of engagement when it is moved through all the positions. Check whether or not the actual position the selector lever is in matches the position shown by the shift position indicator and the transmission body.
5. The method of operating the lever to individual positions correctly should be as shown in the figure.
6. When selector button is pressed in "P", "R", or "N" position without applying forward/backward force to selector lever, check button operation for sticking.
7. Confirm the back-up lamps illuminate only when lever is placed in the "R" position. Confirm the back-up lamps does not illuminate when selector lever is pushed against "R" position in the "P" or "N" position.
8. Confirm the engine can only be started with the selector lever in the "P" and "N" positions. (With selector lever in the "P" position, engine can be started even when selector lever is moved forward and backward.)
9. Check that transmission is locked completely in "P" position.

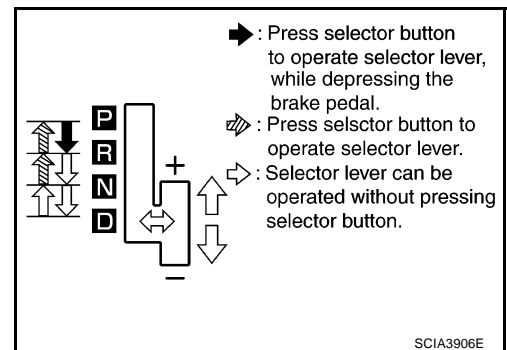

- 
10. When selector lever is set to manual shift gate, check that manual mode is displayed on combination meter.  
Shift selector lever to “+” and “-” sides, and check that set shift position changes.

A

B

**AT**

D

E

F

G

H

I

J

K

L

M

## A/T SHIFT LOCK SYSTEM

PFP:34950

### Description

ACS00009

- The mechanical key interlock mechanism also operates as a shift lock:  
 With the ignition switch turned to ON, the selector lever cannot be shifted from "P" (parking) to any other position unless the brake pedal is depressed.  
 With the key removed, the selector lever cannot be shifted from "P" to any other position.  
 The key cannot be removed unless the selector lever is placed in "P".
- The shift lock and key interlock mechanisms are controlled by the ON-OFF operation of the shift lock solenoid and by the operation of the rotator and slider located inside the key cylinder.

### Shift Lock System Electrical Parts Location

ACS00004

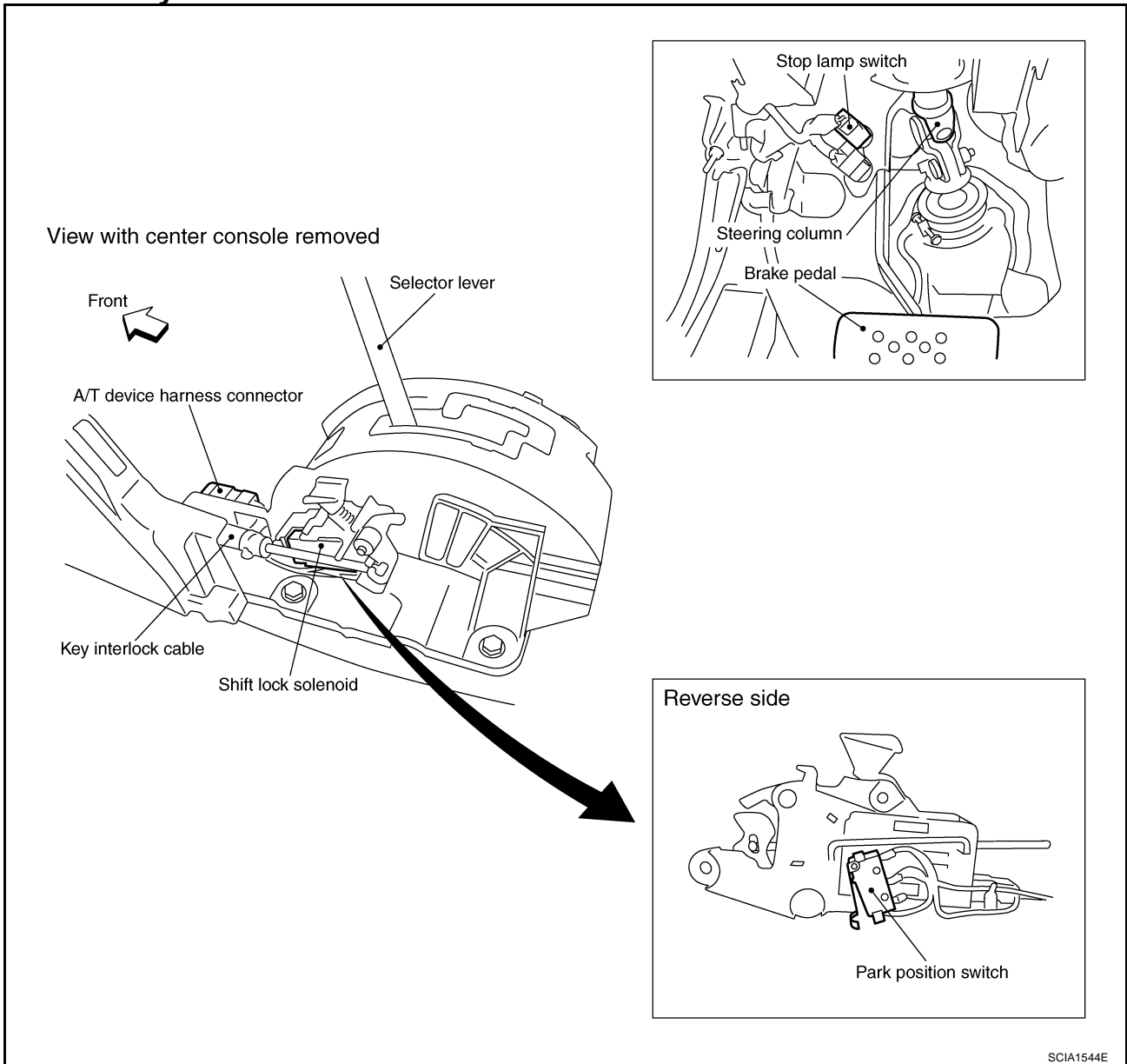



**Wiring Diagram — AT — SHIFT**

ACS001LG

**AT-SHIFT-01**

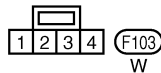
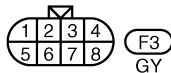
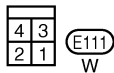
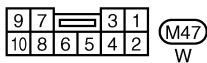
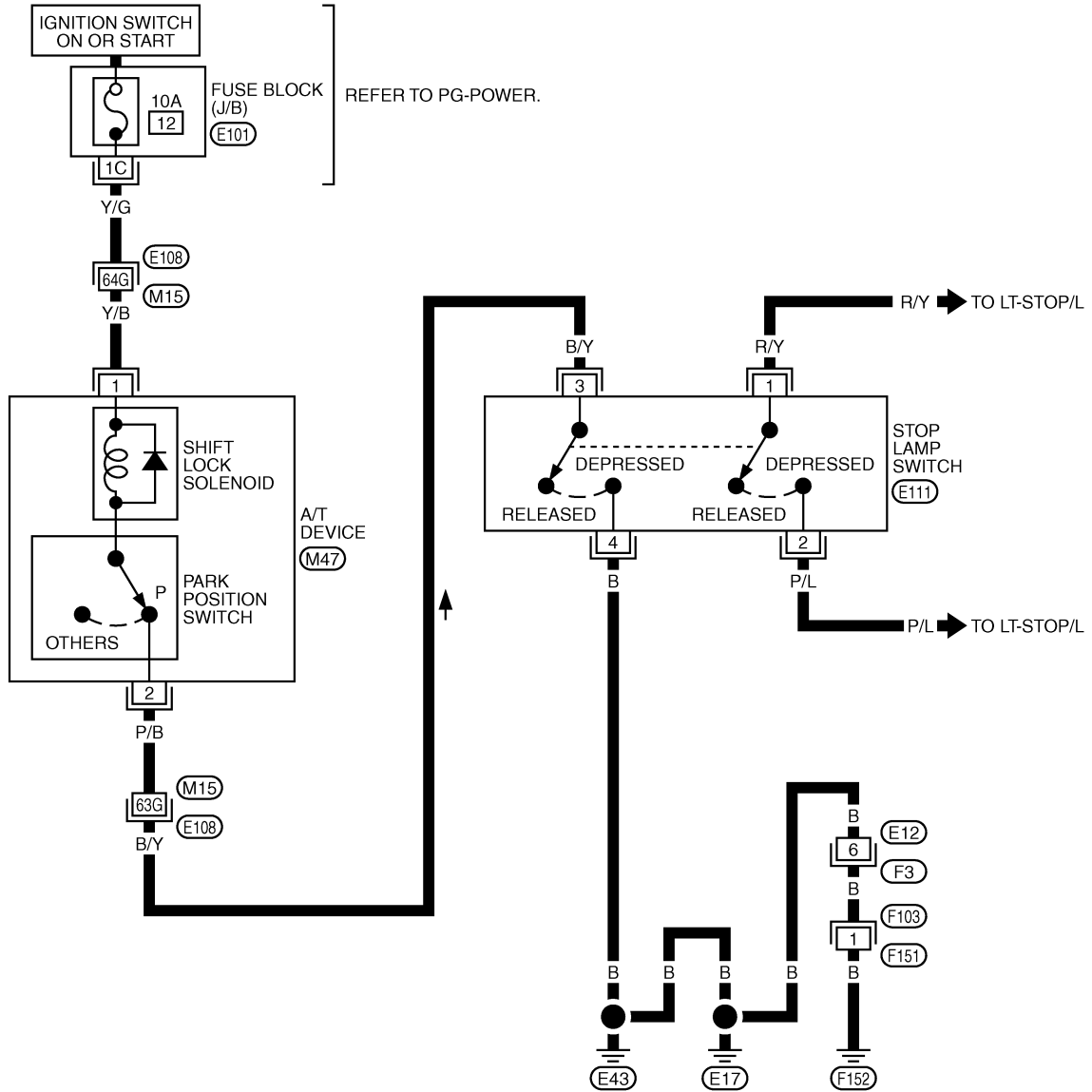

REFER TO THE FOLLOWING.  
 (E108) -SUPER MULTIPLE JUNCTION (SMJ)  
 (E101) -FUSE BLOCK-JUNCTION BOX (J/B)

## Diagnostic Procedure

### SYMPTOM 1:

- Selector lever cannot be moved from “P” position with key in ON position and brake pedal applied.
- Selector lever can be moved from “P” position with key in ON position and brake pedal released.
- Selector lever can be moved from “P” position when key is removed from key cylinder.

### SYMPTOM 2:

- Ignition key cannot be removed when selector lever is set to “P” position.
- Ignition key can be removed when selector lever is set to any position except “P”.

## 1. CHECK KEY INTERLOCK CABLE

Check the key interlock cable for damage.

OK or NG

OK >> GO TO 2.

NG >> Replace key interlock cable. Refer to [AT-188, "KEY INTERLOCK CABLE"](#) .

## 2. CHECK SELECTOR LEVER POSITION

Check the selector lever position for damage.

OK or NG

OK >> GO TO 3.

NG >> Check selector lever. Refer to [AT-182, "Adjustment of A/T Position"](#) .

## 3. CHECK SHIFT LOCK SOLENOID AND PARK POSITION SWITCH

1. Connect A/T device harness connector.
2. Turn ignition switch “ON”.
3. Selector lever is set in “P” position.
4. Check operation.

Condition	Brake pedal	Operation
When ignition switch is turned to “ON” position and selector lever is set in “P” position.	Depressed	Yes
	Released	No

OK or NG

OK >> **INSPECTION END**

NG >> GO TO 4.

## 4. CHECK POWER SOURCE

1. Turn ignition switch “ON”. (Do not start engine.)
2. Check voltage between A/T device harness connector M47 terminal 1 (Y/B) and ground.

**Voltage: Battery voltage**

OK or NG

OK >> GO TO 5.

NG >> GO TO 6.

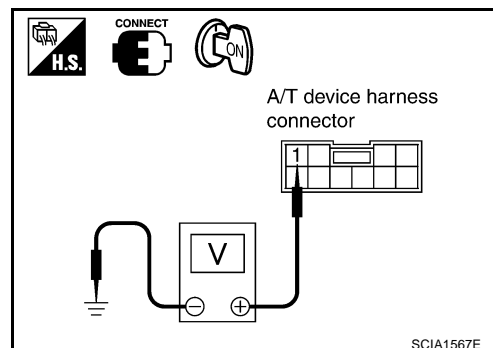

## 5. CHECK STOP LAMP SWITCH

Check continuity between stop lamp switch harness connector E111 terminals 3 (B/Y) and 4 (B).

Stop lamp switch harness connector

Condition	Continuity
When brake pedal is depressed	Yes
When brake pedal is released	No

SCIA3953E

**Check stop lamp switch after adjusting brake pedal — refer to [BR-6, "BRAKE PEDAL"](#) .**

OK or NG

- OK >> GO TO 7.
- NG >> Repair or replace damaged parts.

## 6. DETECT MALFUNCTIONING ITEM

Check the following items. If any items are damaged, repair or replace damaged parts.

1. Harness for short or open between ignition switch and A/T device harness terminal 1
2. 10A fuse [No.12, located in the fuse block (J/B)]
3. Ignition switch (Refer to [PG-4, "POWER SUPPLY ROUTING CIRCUIT"](#) .)

OK or NG

- OK >> **INSPECTION END**
- NG >> Repair or replace damaged parts.

## 7. CHECK GROUND CIRCUIT

1. Turn ignition switch "OFF".
2. Disconnect stop lamp switch harness connector.
3. Check continuity between stop lamp switch harness connector E111 terminal 4 (B) and ground.

**Continuity should exist.**

If OK, check harness for short to ground and short to power.

4. Connect stop lamp switch harness connector.

OK or NG

- OK >> GO TO 8.
- NG >> Repair open circuit or short to ground or short to power in harness or connectors.

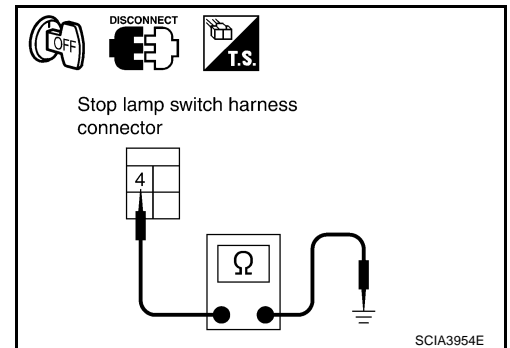

## 8. DETECT MALFUNCTIONING ITEM

Check the following items. If any items are damaged, repair or replace damaged parts.

- Harness for short or open between A/T device harness connector M47 terminal 2 (P/B) and stop lamp switch harness connector E111 terminal 3 (B/Y).

OK or NG

- OK >> Replace shift lock solenoid or park position switch.
- NG >> Repair or replace damaged parts.

# KEY INTERLOCK CABLE

PFP:34908

## Components

ACS0000D

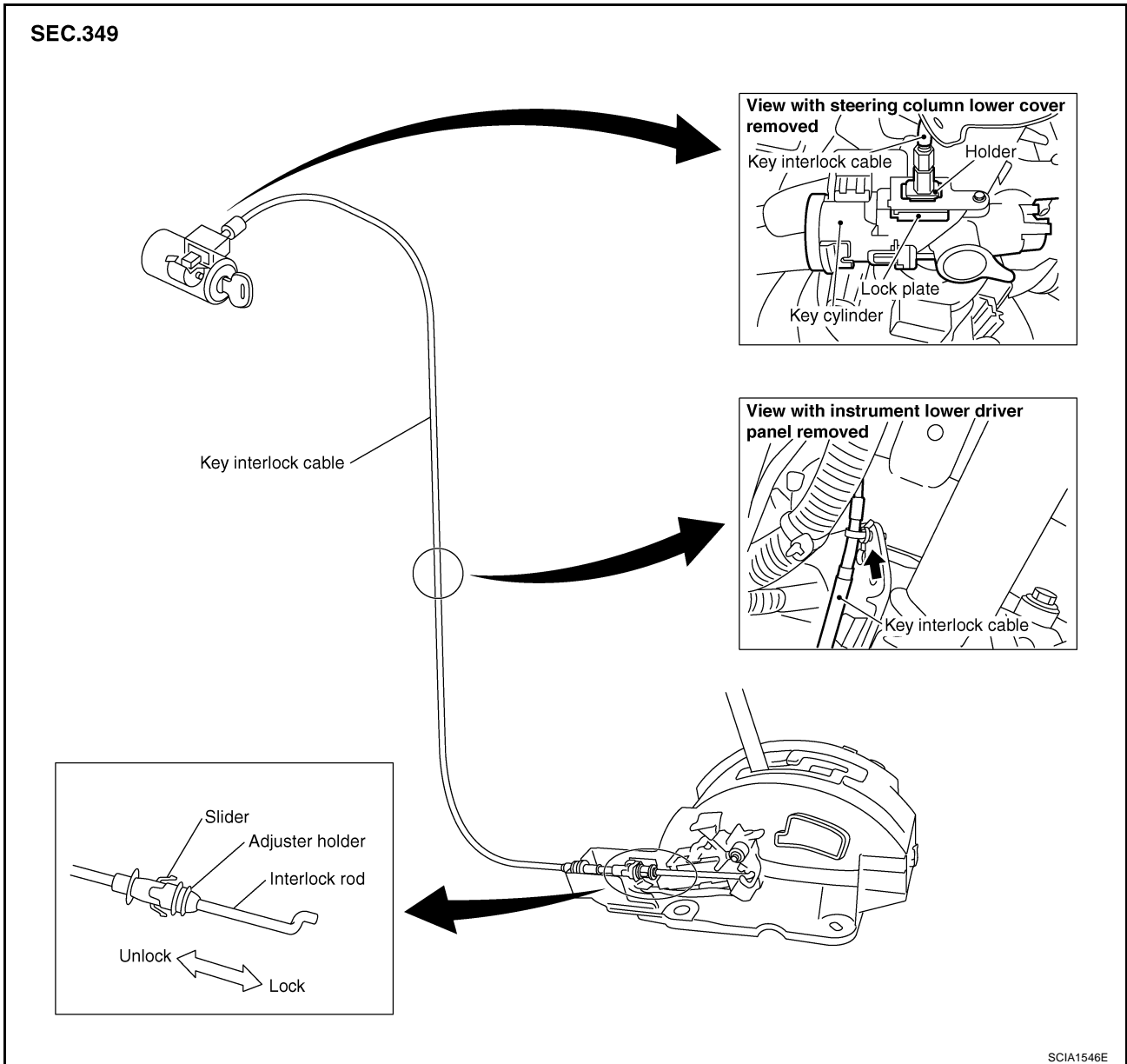

**CAUTION:**

- Install key interlock cable in such a way that it will not be damaged by sharp bends, twists or interference with adjacent parts.
- After installing key interlock cable to control device, make sure that casing cap and bracket are firmly secured in their positions. If casing cap be removed with an external load of less than 39.2 N (4.0 kg, 8.8 lb), replace key interlock cable with new one.

## Removal

1. Unlock slider by squeezing lock tabs on slider from adjuster holder.
2. Remove casing cap from bracket of control device and remove interlock rod from adjuster holder.

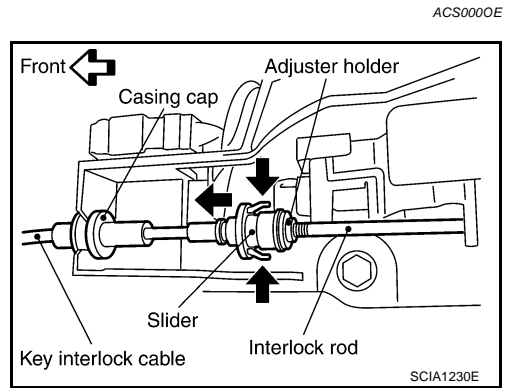

3. Remove lock plate from key cylinder.
4. Remove holder from key cylinder and remove key interlock cable.

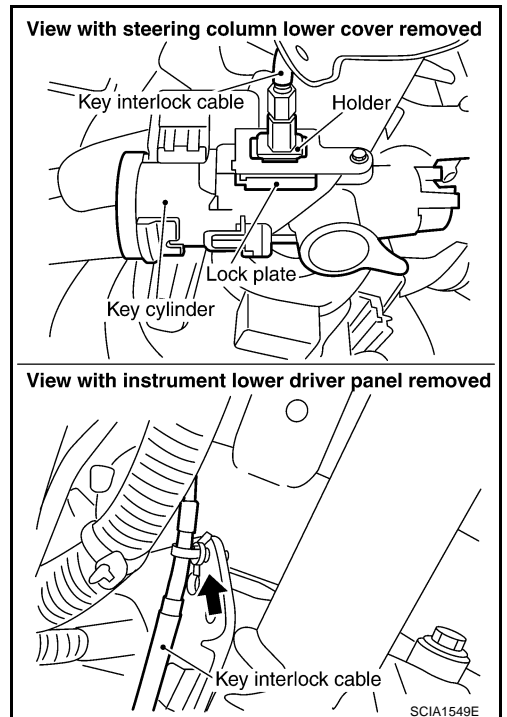

A  
B  
**AT**  
D  
E  
F  
G  
H  
I  
J  
K  
L  
M

## Installation

1. Set holder of key interlock cable to key cylinder and install lock plate.

**CAUTION:**

**Do not reuse the lock plate**

2. Clamp key interlock cable and fix to key interlock cable with band.
3. Turn ignition key to lock position.
4. Set selector lever to P position.

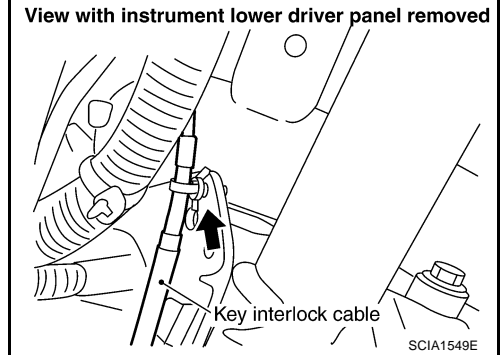
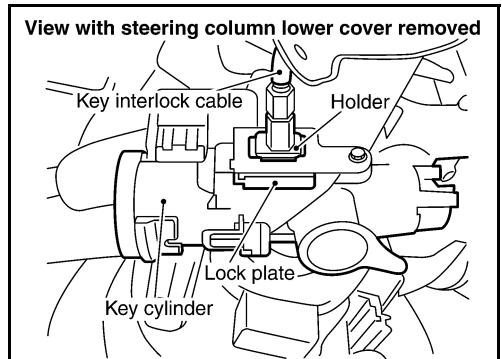

5. Insert interlock rod into adjuster holder.
6. Install casing cap to bracket.
7. Move slider in order to fix adjuster holder to interlock rod.

**CAUTION:**

**Do not touch any parts except slider. Do not add any force to slider except force toward slider.**

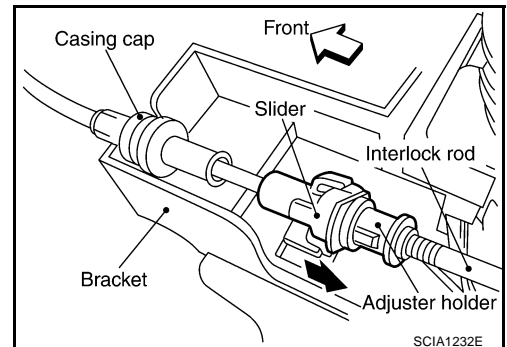

**AIR BREATHER HOSE**  
**Removal and Installation**

PFP:31098

ACS0000G

Refer to the figure below for air breather hose removal and installation procedure.

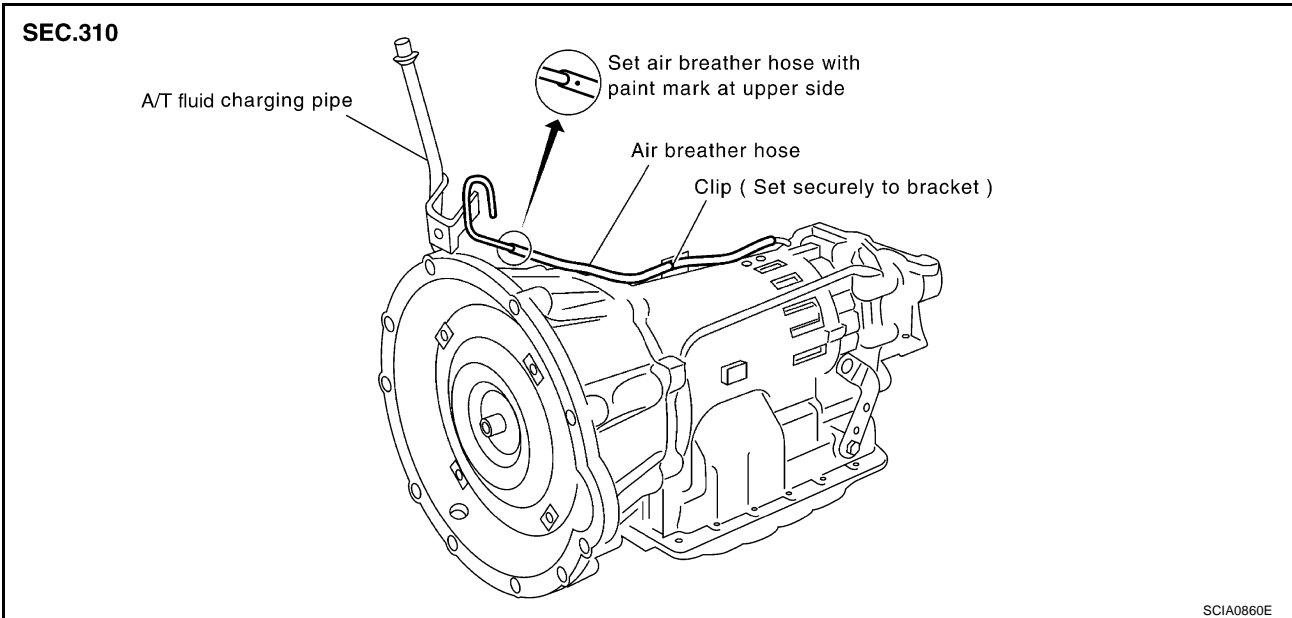

**CAUTION:**

- When installing an air breather hose, be careful not to be crushed or blocked by folding or bending the hose.
- When inserting a hose to the transmission tube, be sure to insert it fully until its end reaches the tube bend R portion.

A  
 B  
 C  
**AT**  
 D  
 E  
 F  
 G  
 H  
 I  
 J  
 K  
 L  
 M

## TRANSMISSION ASSEMBLY

PF3:31020

### Removal and Installation

ACS0000H

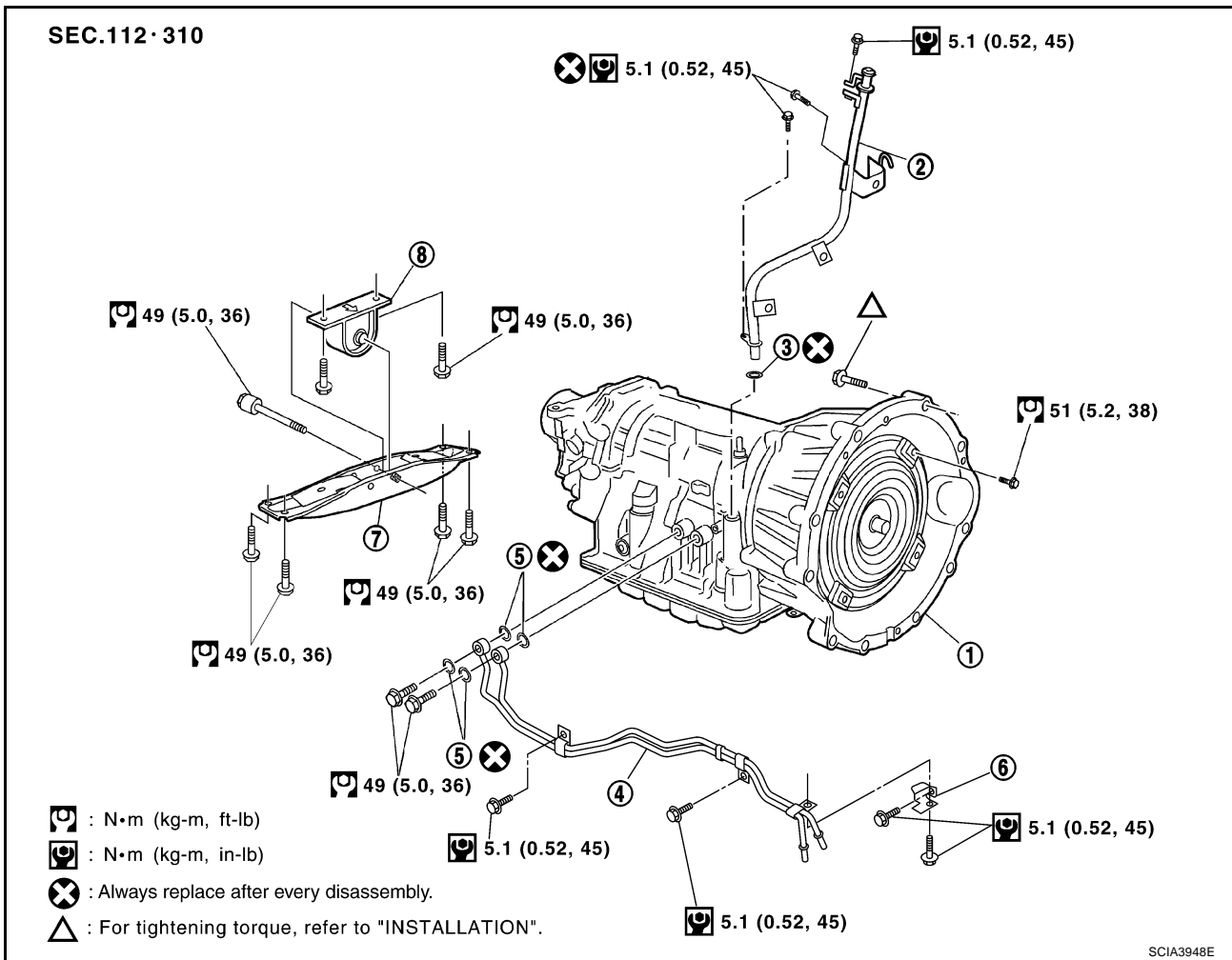

- |                          |                            |            |
|--------------------------|----------------------------|------------|
| 1. Transmission assembly | 2. A/T fluid charging pipe | 3. O-ring  |
| 4. Fluid cooler tube     | 5. Copper washer           | 6. Bracket |
| 7. Engine rear member    | 8. Insulator               |            |

### REMOVAL

#### CAUTION:

When removing the A/T assembly from engine, first remove the crankshaft position sensor (POS) from the A/T assembly.

Be careful not to damage sensor edge.

1. Disconnect the negative battery terminal.
2. Remove tower bar with power tool. Refer to [FSU-20, "Removal and Installation"](#) .
3. Remove engine under cover with power tool.
4. Remove front cross bar with power tool. Refer to [FSU-19, "Removal and Installation"](#) .
5. Remove exhaust tube with power tool. Refer to [EX-3, "Removal and Installation"](#) .
6. Remove propeller shaft. Refer to [PR-7, "Removal and Installation"](#) .

#### CAUTION:

Do not impact, or damage propeller shaft tube.

7. Remove control rod. Refer to [AT-181, "SHIFT CONTROL SYSTEM"](#) .
8. Disconnect A/T assembly connector.



9. Remove crankshaft position sensor (POS) from A/T assembly. Refer to [EM-28, "Removal and Installation"](#) .

**CAUTION:**

- Do not subject it to impact by dropping or hitting it.
- Do not disassemble.
- Do not allow metal filings, etc., to get on the sensor's front edge magnetic area.
- Do not place in an area affected by magnetism.

10. Remove fluid cooler tube and A/T fluid charging pipe.  
 11. Plug up openings such as the fluid charging pipe hole, etc.  
 12. Remove air breather hose. Refer to [AT-191, "Removal and Installation"](#) .  
 13. Remove starter motor with power tool. Refer to [SC-19, "Removal and Installation"](#) .  
 14. Remove dust cover from converter housing part.  
 15. Turn crankshaft, and remove the four tightening bolts for drive plate and torque converter.

**CAUTION:**

**When turning crankshaft, turn it clockwise as viewed from the front of the engine.**

16. Support transmission assembly with a transmission jack.

**CAUTION:**

**When setting the transmission jack, be careful not to allow it to collide against the drain plug.**

17. Remove engine rear member with power tool.  
 18. Remove bolts fixing transmission assembly to engine with power tool.  
 19. Remove transmission assembly from vehicle with a transmission jack.

- Secure torque converter to prevent it from dropping.
- Secure transmission assembly to a transmission jack.

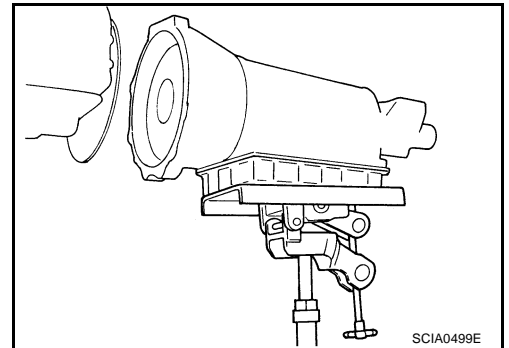
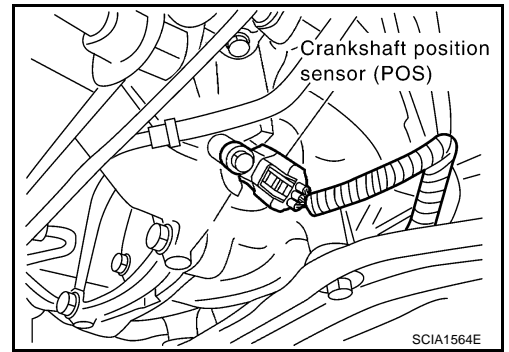

## INSPECTION

### Installation and inspection of torque converter

- After inserting a torque converter to a transmission, be sure to check dimension A to ensure it is within the reference value limit.

**Dimension A : 25.0 mm (0.98 in) or more**

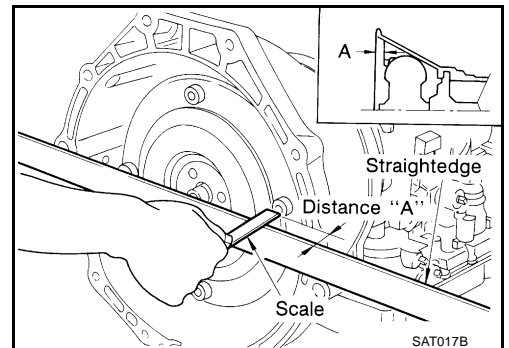

## INSTALLATION

Install the removed parts in the reverse order of the removal, while paying attention to the following work.

- When installing transmission assembly to the engine, attach the fixing bolts in accordance with the following standard.

Bolt No.	1	2	3	4
Number of bolts	1	5	2	2
Bolt length "ℓ"mm (in)	55 (2.17)	65 (2.56)	56 (2.20)	35 (1.38)
Tightening torque N·m (kg·m, ft·lb)	70 - 80 (7.2 - 8.1, 52 - 59)		49.0 - 61.8 (5.0 - 6.3, 37 - 45)	41.2 - 52.0 (4.2 - 5.3, 31 - 38)

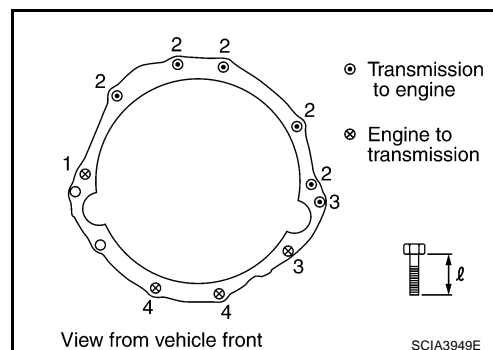

- Align the positions of tightening bolts for drive plate with those of the torque converter, and temporarily tighten the bolts. Then, tighten the bolts with the specified torque.

: 44 - 58 N·m (4.5 - 5.9 kg·m, 33 - 42 ft·lb)

### CAUTION:

- When turning crankshaft, turn it clockwise as viewed from the front of the engine.
- When tightening the tightening bolts for the torque converter after fixing the crankshaft pulley bolts, be sure to confirm the tightening torque of the crankshaft pulley mounting bolts.
- After converter is installed to drive plate, rotate crankshaft several turns and check to be sure that transmission rotates freely without binding.
- Install crankshaft position sensor (POS). Refer to [EM-28, "Removal and Installation"](#).
- After completing installation, check fluid leakage, fluid level, and the A/T positions of A/T. Refer to [AT-10, "Checking A/T Fluid"](#), [AT-182, "Adjustment of A/T Position"](#), [AT-182, "Checking of A/T Position"](#).

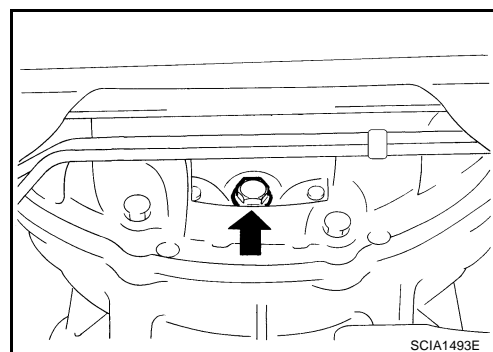

## SERVICE DATA AND SPECIFICATIONS (SDS)

PPF:00030

### General Specifications

ACS0000I

Applied model	VQ35DE engine	
Automatic transmission model	RE5R05A	
Transmission model code number	92X06	
Stall torque ratio	2.0: 1	
Transmission gear ratio	1st	3.540
	2nd	2.264
	3rd	1.417
	4th	1.000
	5th	0.834
	Reverse	2.370
Recommended fluid	Nissan Matic J ATF*1	
Fluid capacity	10.3 liter (10-7/8 US qt, 9-1/8 Imp qt)	

**CAUTION:**

- Use only Genuine Nissan Matic J ATF. Do not mix with other fluid.
- Using automatic transmission fluid other than Genuine Nissan Matic J ATF will deteriorate in driveability and automatic transmission durability, and may damage the automatic transmission, which is not covered by the NISSAN new vehicle limited warranty.

\*1: Refer to [MA-11. "Fluids and Lubricants"](#).

### Vehicle Speed When Shifting Gears

ACS0000J

Throttle position	Vehicle Speed km/h (MPH)							
	D1 →D2	D2 →D3	D3 →D4	D4 →D5	D5 →D4	D4 →D3	D3 →D2	D2 →D1
Full throttle	58 - 62 (36 - 39)	90 - 98 (56 - 61)	140 - 150 (87 - 93)	201 - 211 (125 - 131)	197 - 207 (122 - 129)	122 - 132 (76 - 82)	74 - 82 (46 - 51)	34 - 38 (23 - 25)
Half throttle	46 - 50 (29 - 31)	71 - 79 (44 - 49)	107 - 117 (66 - 73)	135 - 145 (84 - 90)	88 - 98 (55 - 61)	63 - 73 (39 - 45)	29 - 37 (18 - 23)	11 - 15 (7 - 9)

- At half throttle, the accelerator opening is 4/8 of the full opening.

### Vehicle Speed When Performing and Releasing Complete Lock-up

ACS0000K

Throttle position	Vehicle speed km/h (MPH)	
	Lock-up "ON"	Lock-up "OFF"
Closed throttle	56 - 64 (35 - 40)	53 - 61 (33 - 38)
Half throttle	168 - 176 (104 - 109)	131 - 139 (81 - 86)

- At closed throttle, the accelerator opening is less than 1/8 condition.
- At half throttle, the accelerator opening is 4/8 of the full opening.

### Vehicle Speed When Performing and Releasing Slip Lock-up

ACS0000L

Throttle position	Gear position	Vehicle speed km/h (MPH)	
		Slip lock-up "ON"	Slip lock-up "OFF"
Closed throttle	4th	37 - 45 (23 - 28)	34 - 42 (21 - 26)
	5th	44 - 52 (27 - 32)	41 - 49 (25 - 30)

- At closed throttle, the accelerator opening is less than 1/8 condition.

### Stall Speed

ACS0000M

Stall speed	2,650 - 2,950 rpm
-------------	-------------------

**Line Pressure**

ACS0000N

Engine speed	Line pressure [kPa (kg/cm <sup>2</sup> , psi)]	
	R position	D, M positions
At idle speed	392 - 441 (4.0 - 4.5, 57 - 64)	373 - 422 (3.8 - 4.3, 54 - 61)
At stall speed	1,700 - 1,890 (17.3 - 19.3, 247 - 274)	1,310 - 1,500 (13.3 - 15.3, 190 - 218)