



AXOD/AXODE (AX4S) UPDATE HANDBOOK

[GOTO PAGE](#)

INDEX

[PREVIOUS](#)
[MENU](#)

AXOD AND AXODE

HYDRAULIC SYSTEM CHANGES	4
SPACER PLATE IDENTIFICATION	9
PUMP AND VALVE BODY GASKET IDENTIFICATION	14
VALVE BODY CHECKBALL LOCATIONS	21
OIL PUMP CHECKBALL LOCATIONS	22
VALVE BODY VALVE LOCATIONS AND IDENTIFICATION	26
PREMATURE PLANETARY FAILURE	34
INTERMEDIATE CLUTCH PACK CHANGES	40
NEW STEEL FORWARD CLUTCH PISTON	48
HARSH COASTDOWN SHIFT	49
SPROCKET RATIO IDENTIFICATION (ALL)	51
NEW DESIGN OIL PUMP BEARING WITH INTEGRAL SEAL	56
ACCUMULATOR SPRING IDENTIFICATION (ALL)	58
LOW SPRAG FREE WHEEL DIRECTION	62
FORWARD CLUTCH WAVE PLATE CHANGE	64
FORWARD CLUTCH PACK AND LOW SPRAG OUTER RACE CHANGE	68
NEW DESIGN INPUT PLANETARY AND SUN SHELL	72
NO MOVEMENT OR NO TCC	75

AXODE

OIL PUMP CHECKBALL LOCATION CHANGES	76
TORQUE CONVERTER AND TURBINE SHAFT SPLINE CHANGES	79
VALVE BODY VALVE LOCATIONS AND IDENTIFICATION	80
VALVE BODY AND OIL PUMP SPACER PLATE IDENTIFICATION	88
OIL PUMP AND VALVE BODY GASKET IDENTIFICATION	89
VALVE BODY CHECKBALL LOCATION CHANGES	92
PREMATURE PLANETARY FAILURE	95
CHAIN COVER AND THRUST WASHER CHANGES	96
1991-1992 ELECTRICAL DIAGNOSIS	100
NEW DESIGN CHAIN COVER KIT FOR NEW CASE CONNECTOR	103
1993-UP ELECTRICAL DIAGNOSIS	104
NEW DESIGN TCC SOLENOID	106
VEHICLE SPEED SENSOR CHANGES	108
PRESSURE TAP LOCATIONS	111
PRESSURE CONTROL PROBLEM DIAGNOSIS	112
WINDSTAR AND TAURUS SPACER PLATE IDENTIFICATION	116
LATEST CHAIN COVER AND GASKET CHANGE (NO REVERSE)	119

AUTOMATIC TRANSMISSION SERVICE GROUP
9200 S. DADELAND BLVD. SUITE 720
MIAMI, FLORIDA 33156
(305) 670-4161



INTRODUCTION

*Updated
October, 2002*

Since the introduction of the Ford AXOD transaxle in model year 1986, there have been many major engineering design changes that have affected many of the parts used in the AXOD transaxle. This version of the AXOD "Update Handbook" begins with the 1986 model year and will explain each change, the parts affected by the change, and any parts interchange problems created by the change. This booklet is an updated version of the original.

This updated version of the AXOD "Update Handbook" will also cover the changes that occurred in the 1991 model year, when electronic controls were adapted to the AXOD transaxle, making it an AXODE, and now called an AX4S transaxle. We have included the changes on the AX4S transaxle up through and including model year 2002.

We wish to thank Ford Motor Company for the information and illustrations that have made this possible.

No part of any ATSG publication may be reproduced, stored in any retrieval system or transmitted in any form or by any means, including but not limited to electronic, mechanical, photocopying, recording or otherwise, without *written* permission of Automatic Transmission Service Group. This includes all text illustrations, tables and charts.

The information and part numbers contained in this booklet have been carefully compiled from industry sources known for their reliability, but ATSG does not guarantee its accuracy.

Copyright © ATSG 2002

DALE ENGLAND
FIELD SERVICE CONSULTANT

WAYNE COLONNA
TECHNICAL SUPERVISOR

PETER LUBAN
TECHNICAL CONSULTANT

JON GLATSTEIN
TECHNICAL CONSULTANT

JERRY GOTT
TECHNICAL CONSULTANT

GERALD CAMPBELL
TECHNICAL CONSULTANT

JIM DIAL
TECHNICAL CONSULTANT

ED KRUSE
TECHNICAL CONSULTANT

GREGORY LIPNICK
TECHNICAL CONSULTANT

DAVID CHALKER
TECHNICAL CONSULTANT

STANTON ANDERSON
TECHNICAL CONSULTANT

ROLAND ALVAREZ
TECHNICAL CONSULTANT

AUTOMATIC TRANSMISSION SERVICE GROUP
9200 S. DADELAND BLVD. SUITE 720
MIAMI, FLORIDA 33156
(305) 670-4161



Technical Service Information

APPLICATION CHART

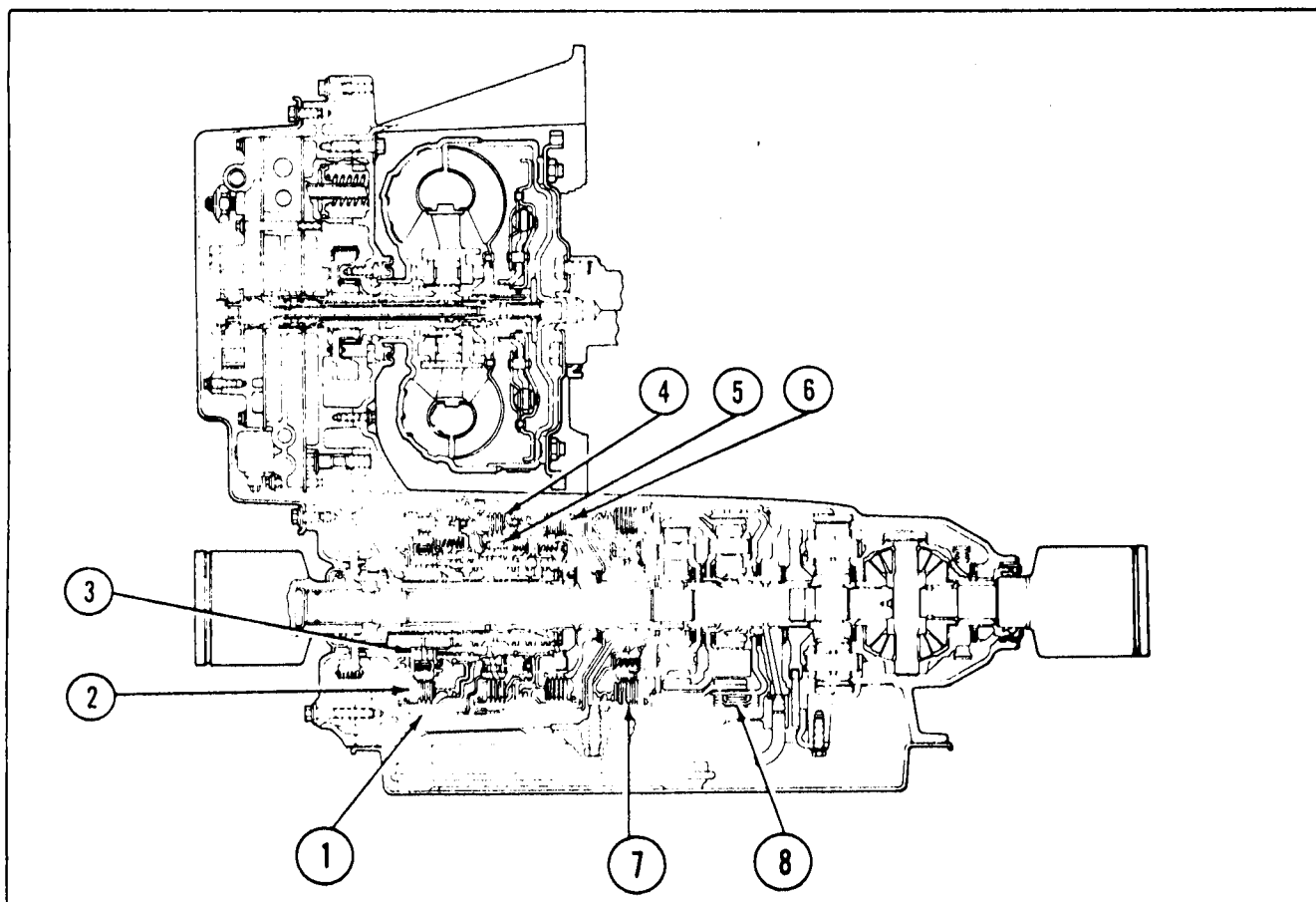

GEAR	OVER DRIVE BAND	FOR- WARD CLUTCH	LOW ONE-WAY CLUTCH	DIRECT CLUTCH	DIRECT ONE-WAY CLUTCH	INTER- MEDIATE CLUTCH	REV CLUTCH	LOW INTER. BAND	RATIO
MANUAL LOW		APPLIED	HOLD	APPLIED				APPLIED	2.77:1
• COASTING		APPLIED		APPLIED	HOLD			APPLIED	2.77:1
DRIVE 1st GEAR		APPLIED	HOLD					APPLIED	2.77:1
• COASTING		APPLIED	O/R					APPLIED	Freewheel
DRIVE 2nd GEAR		APPLIED	O/R			APPLIED		APPLIED	1.543:1
DRIVE 3rd GEAR		APPLIED		APPLIED	HOLD	APPLIED			1.000:1
• COASTING		APPLIED	HOLD	APPLIED					1.000:1
DRIVE 4th GEAR	APPLIED			APPLIED	O/R	APPLIED			.694:1
REVERSE		APPLIED	HOLD				APPLIED		2.263:1

AUTOMATIC TRANSMISSION SERVICE GROUP



Technical Service Information

CHANGE: The calibration and hydraulic system changed in 1987, again in 1988, again in 1989 on some models, and again in 1990 on all models.

REASON: In an effort to improve coast downshifts and forced downshifts.

NOTE: IT IS "IMPERATIVE" THAT THE HYDRAULIC SYSTEM BE PROPERLY IDENTIFIED DURING YOUR REBUILD.

PARTS AFFECTED:

- (1) OIL PUMP CASTING - Must be identified by the casting number located on the pump as shown in Figure 1, and can be identified as follows:
 - E6SP-7B324-AA = 1986 Hydraulics.
 - E7DP-7B324-AA = 1987 Hydraulics.
 - E8DP-7B324-AA = 1988 Hydraulics.
 - E9OP-7B324-AA = 89/90 Hydraulics (10 Checkball Pump).

NOTE: Some 1987 models had 1986 pumps, but had 1987 spacer plate, and requires 1987 pump spacer plate gaskets.
The 1986-1989 oil pumps have 9 checkballs, see Figure 16.
The 1990 oil pumps have 10 checkballs, see Figure 17.
- (2) OIL PUMP SPACER PLATE - Must be identified by the "Notches" in the spacer plate as shown in Figures 4, 5, 6, and 7.

NOTE: Some 1987 models had 1986 pumps, but had 1987 spacer plate, and requires 1987 pump spacer plate gaskets.
- (3) OIL PUMP SPACER PLATE GASKETS - Must be identified by "Color Stripe" located on the gaskets as follows:
 - NONE I.D. STRIPE = 1986 Hydraulics Only.
 - WHITE I.D. STRIPE = 1987 Hydraulics Only.
 - YELLOW I.D. STRIPE = 88/89 Hydraulics Only.
 - BLUE I.D. STRIPE = 1990 Hydraulics Only (10 Checkball Pump).

Refer to Figures 8, 10, 12, and 14.

NOTE: Some 1987 models had 1986 pumps, but had 1987 spacer plate, and requires 1987 pump spacer plate gaskets.
- (4) VALVE BODY CASTING - Must be identified by the casting number located beneath the lock-up solenoid as shown in Figure 2, and can be identified as follows:
 - E6SP-7A092-AD = 1986 Hydraulics Only.
 - E7DP-7A092-BA = 1987 Hydraulics Only.
 - E8DP-AA = 88/90 Hydraulics Only.

NOTE: Checkball locations in the valve body have remained the same for ALL model years and are shown in Figure 15.
- (5) VALVE BODY SPACER PLATE - Must be identified by the "Notches" in the spacer plate as shown in Figures 4, 5, and 6.
- (6) VALVE BODY SPACER PLATE GASKETS - Must be identified by "Color Stripe" located on the gaskets as follows:
 - NONE I.D. STRIPE = 1986 Hydraulics Only.
 - WHITE I.D. STRIPE = 1987 Hydraulics Only.
 - YELLOW I.D. STRIPE = 88/90 Hydraulics Only.

Refer to Figures 9, 11, and 13.



Technical Service Information

PARTS AFFECTED: (Continued)

- (7) CHAIN COVER - Must be identified by the casting number located below the axle seal as shown in Figure 3, and can be identified as follows:
 E6SP-7G234-AA = 1986 Hydraulics Only.
 E7DP-7G234-AA = 1987 Hydraulics Only.
 E8DP-7G234-AA = 88/90 Hydraulics Only.
- (8) OIL PUMP CHECKBALL LOCATIONS - The 1986 through 1989 oil pumps have 9 checkballs, and locations are shown in Figure 16.
 Some 1989 models and all 1990 model oil pumps have 10 checkballs, and locations are shown in Figure 17.

INTERCHANGEABILITY:

NONE of the "Parts Affected" listed above will interchange with one another, unless so stated under the specific part.

SERVICE INFORMATION:

1986 Pump to Pump Spacer Plate Gasket (NO Stripe)	E6DZ-7G331-A
1986 Pump Spacer Plate to V.B. Gasket (NO Stripe)	E6DZ-7A136-A
1986 V.B. to V.B. Spacer Plate Gasket (NO Stripe)	E6DZ-7D100-A
1986 V.B. Spacer Plate to Cover Gasket(NO Stripe).....	E6DZ-7C155-A
1987 Pump to Pump Spacer Plate Gasket (WHITE Stripe)	E7DZ-7G331-A
1987 Pump Spacer Plate to V.B. Gasket (WHITE Stripe)	E7DZ-7A136-A
1987 V.B. to V.B. Spacer Plate Gasket (WHITE Stripe)	E7DZ-7D100-A
1987 V.B. Spacer Plate to Cover Gasket(WHITE Stripe)	E7DZ-7C155-A
88/89 Pump to Pump Spacer Plate Gasket (YELLOW Stripe)	E8DZ-7G331-A
88/89 Pump Spacer Plate to V.B. Gasket (YELLOW Stripe)	E8DZ-7A136-A
88/90 V.B. to V.B. Spacer Plate Gasket (YELLOW Stripe)	E8DZ-7D100-A
88/90 V.B. Spacer Plate to Cover Gasket(YELLOW Stripe)	E8DZ-7C155-A
1990 Pump to Pump Spacer Plate Gasket (BLUE Stripe)	E90Y-7G331-A
1990 Pump Spacer Plate to V.B. Gasket (BLUE Stripe)	E90Y-7A136-A
Checkballs ALL models (5 per Package)	E7DZ-7E195-A



Technical Service Information

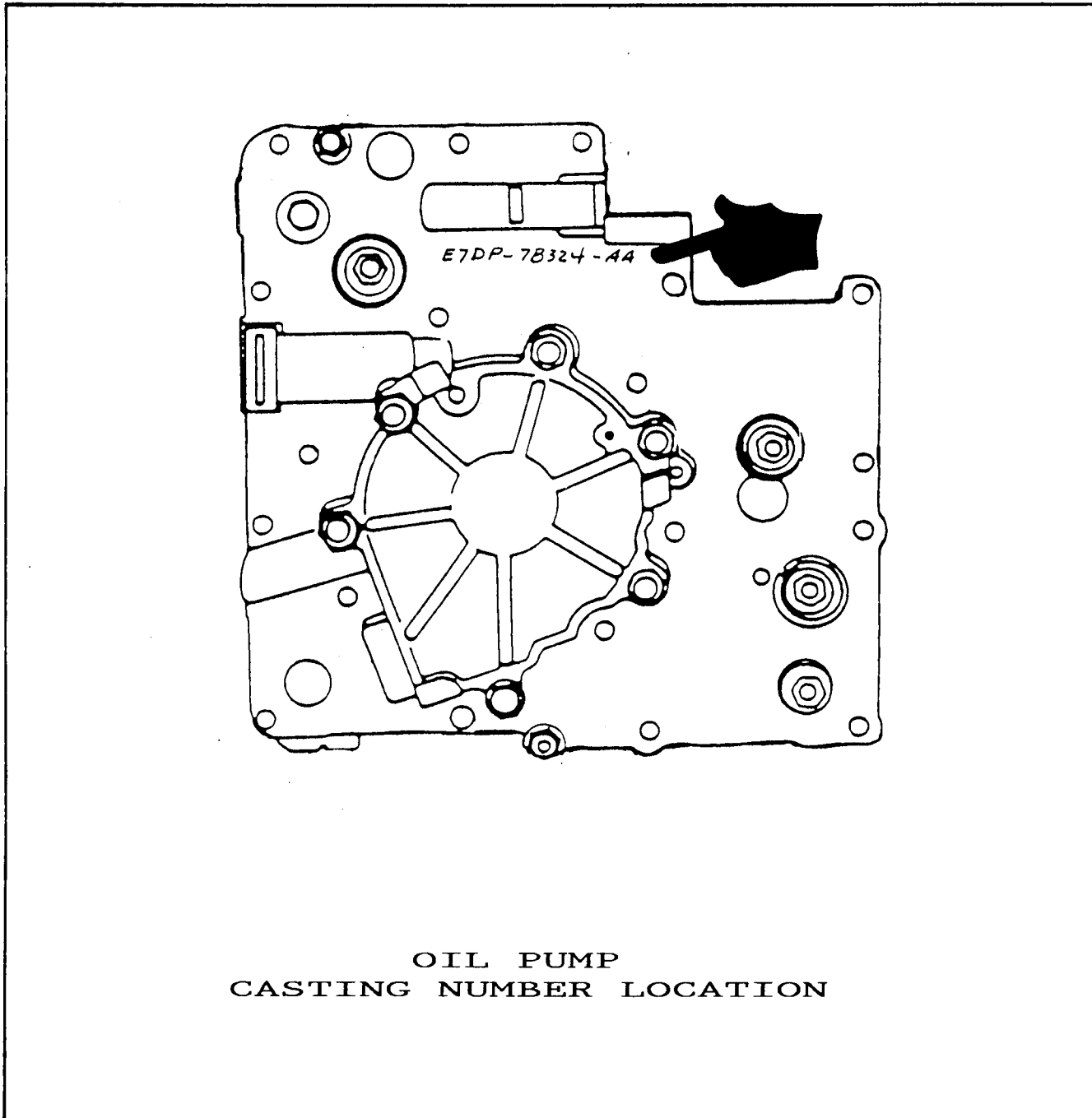
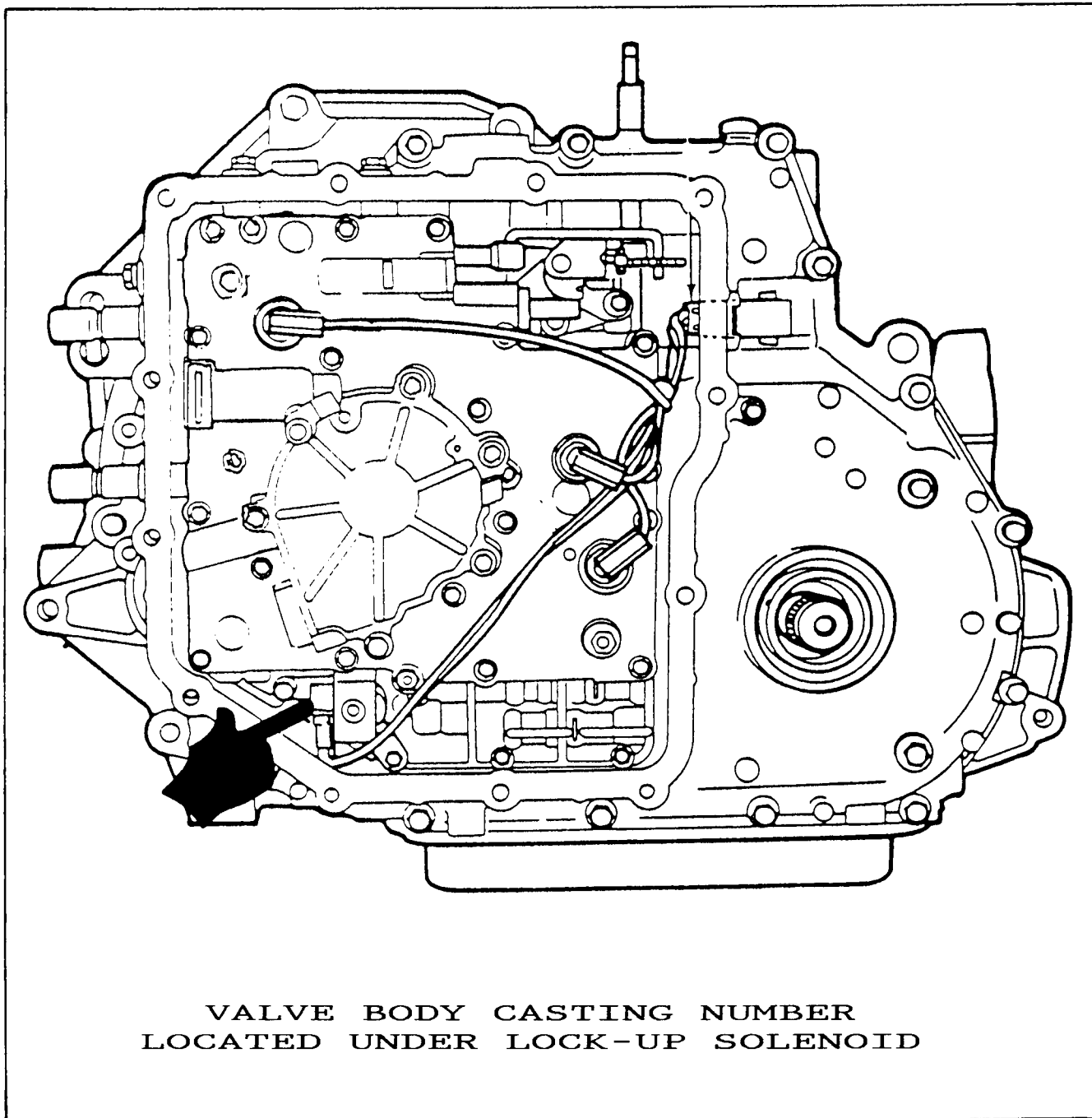

Figure 1



Technical Service Information



VALVE BODY CASTING NUMBER
LOCATED UNDER LOCK-UP SOLENOID

Figure 2



Technical Service Information

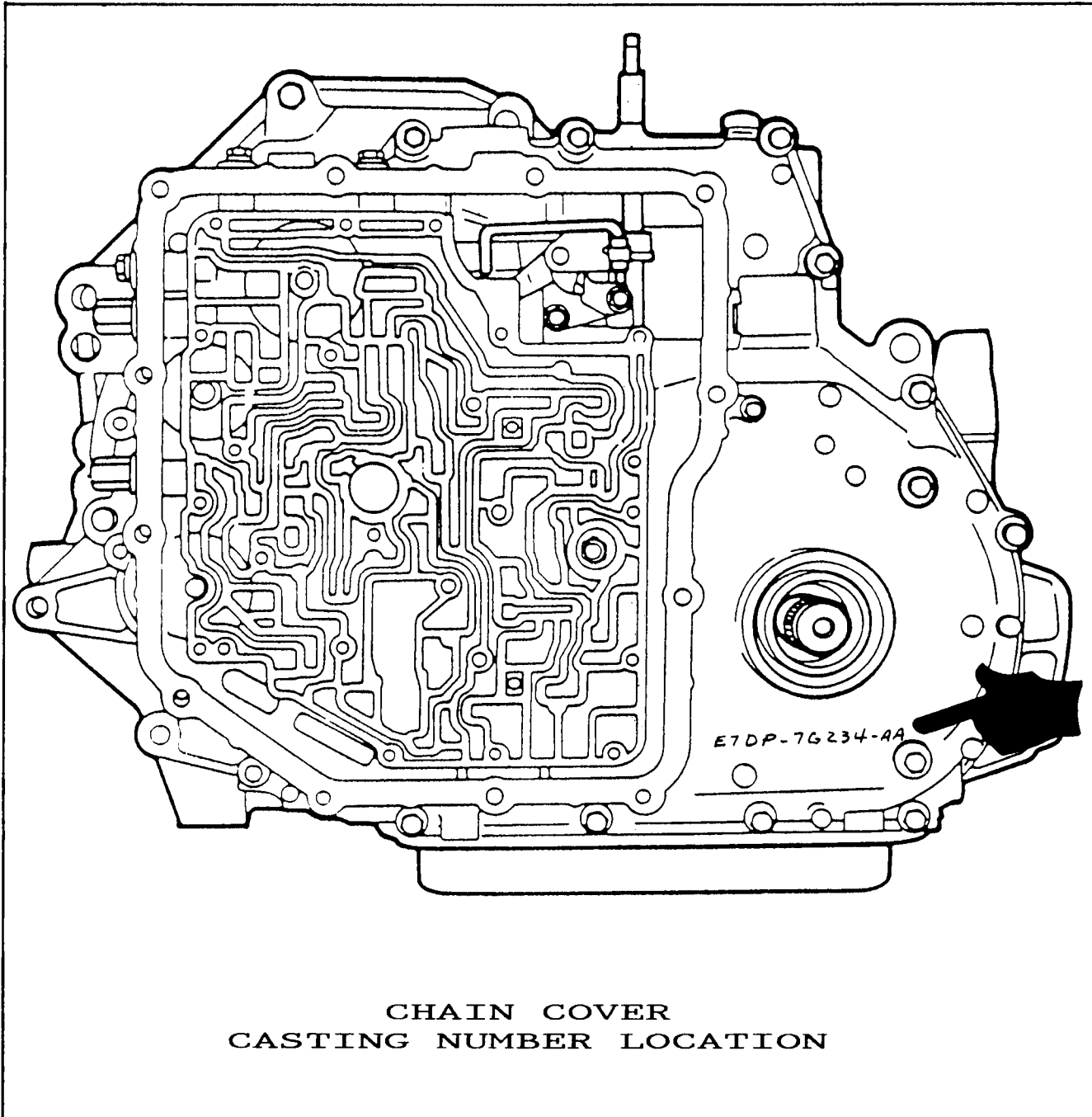

Figure 3



Technical Service Information

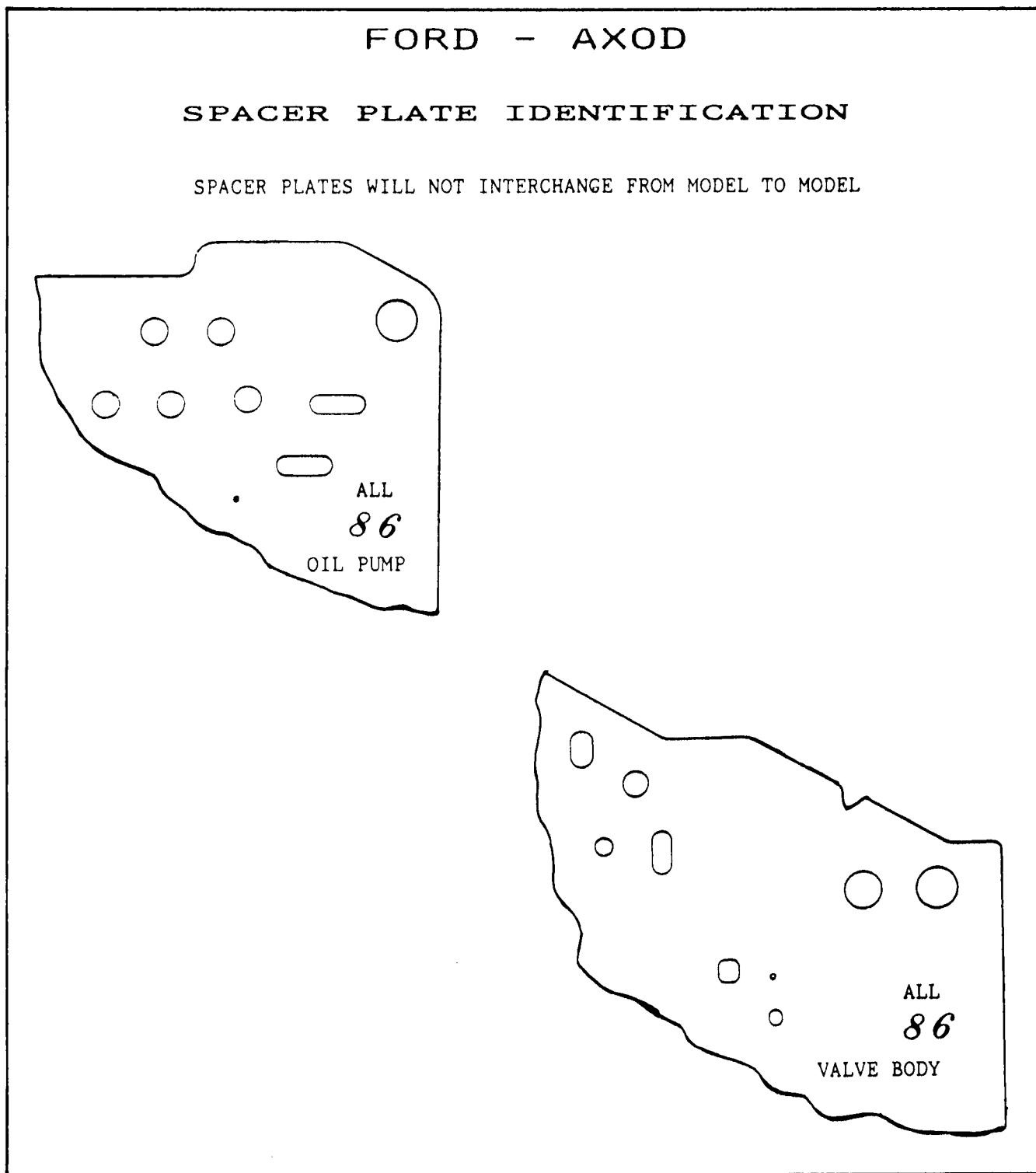

Figure 4



Technical Service Information

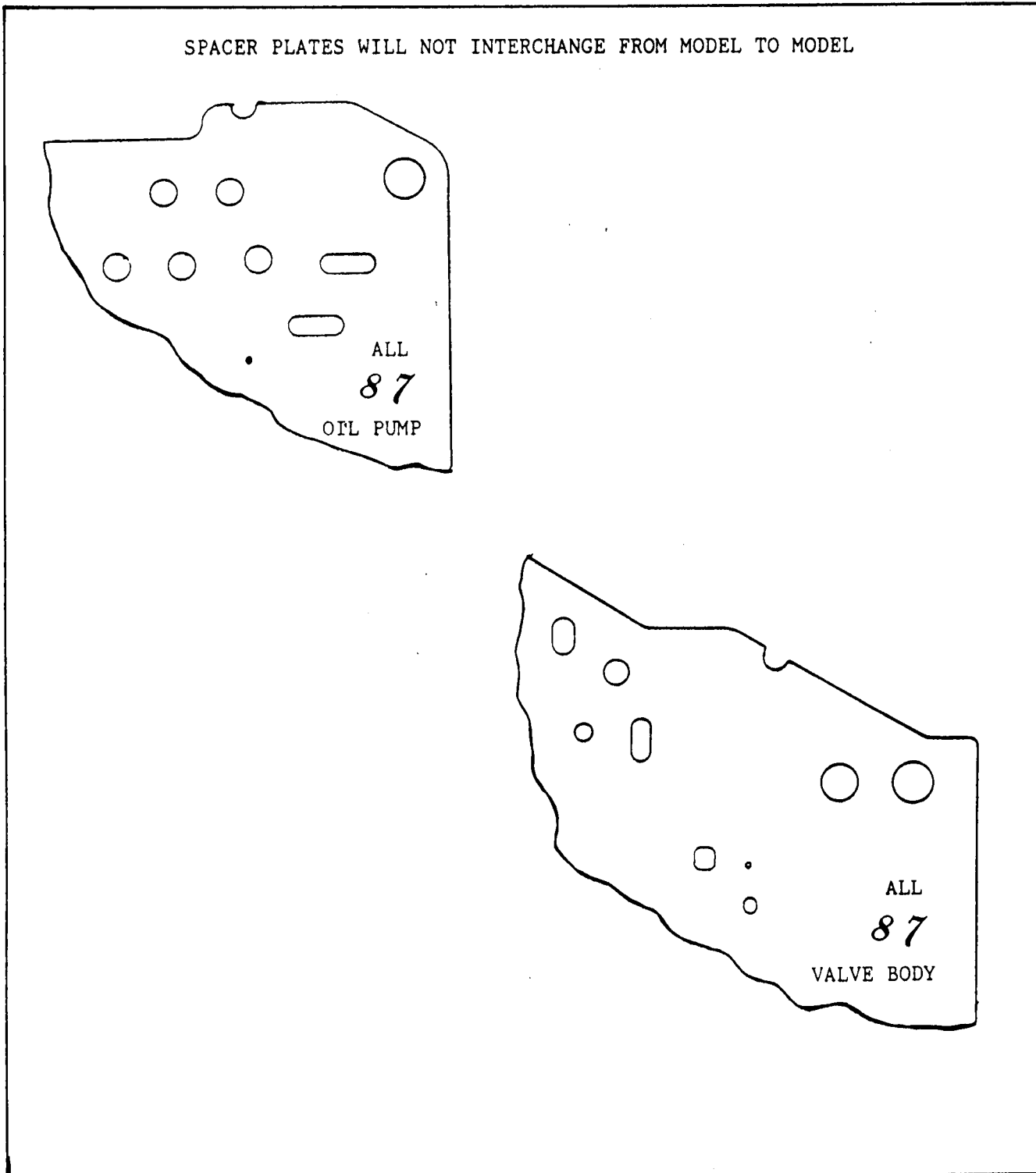

Figure 5



Technical Service Information

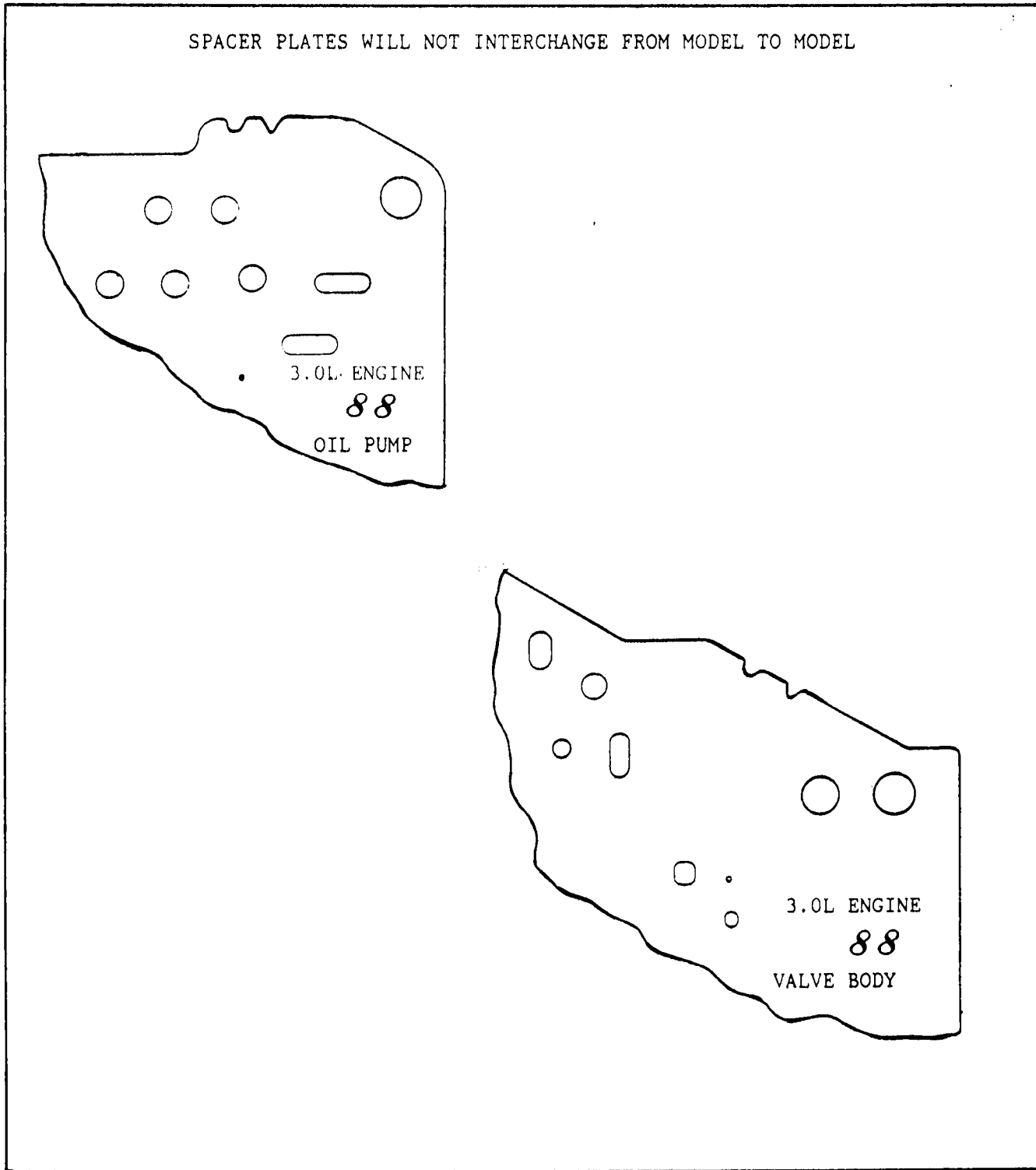

Figure 6



Technical Service Information

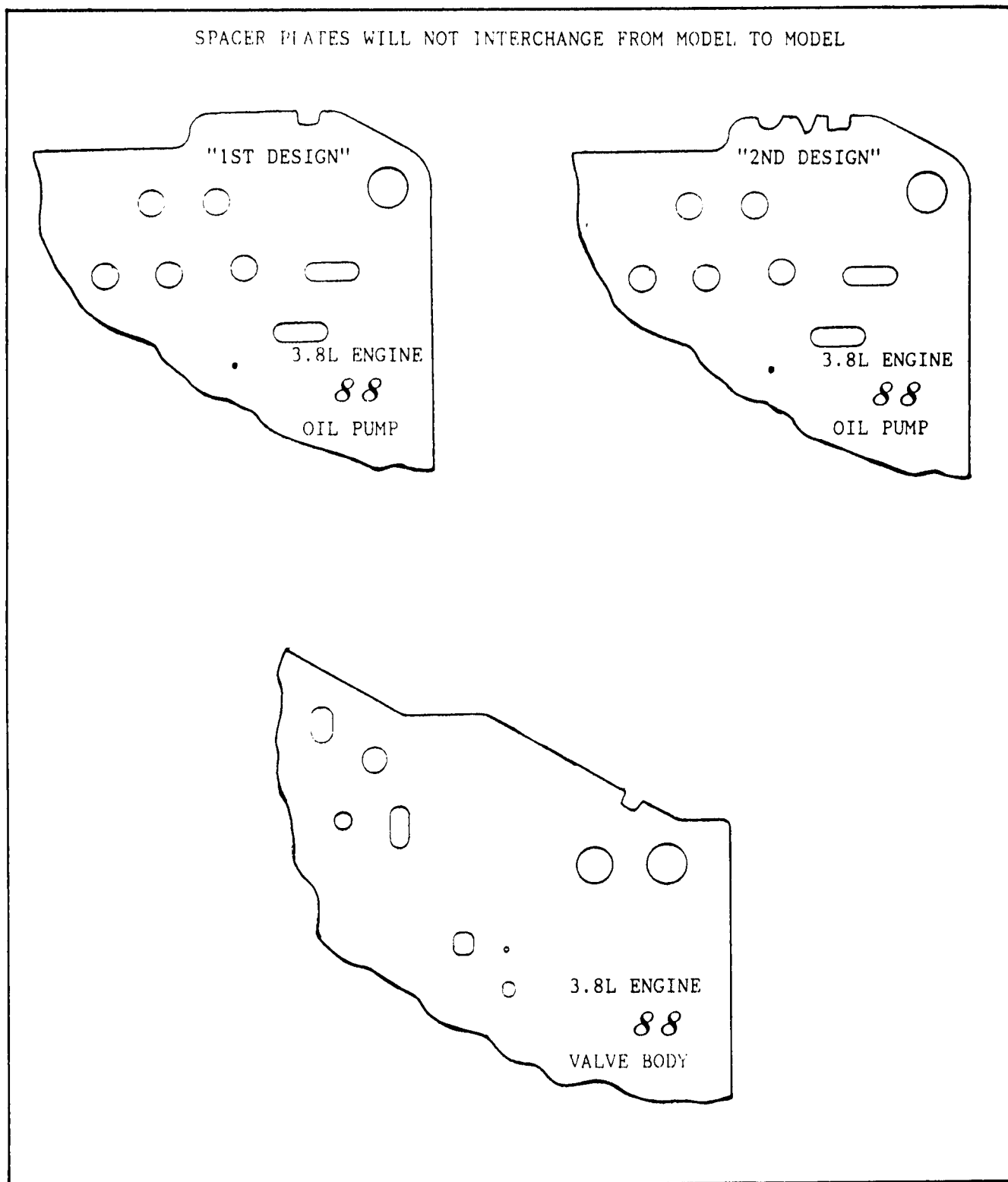
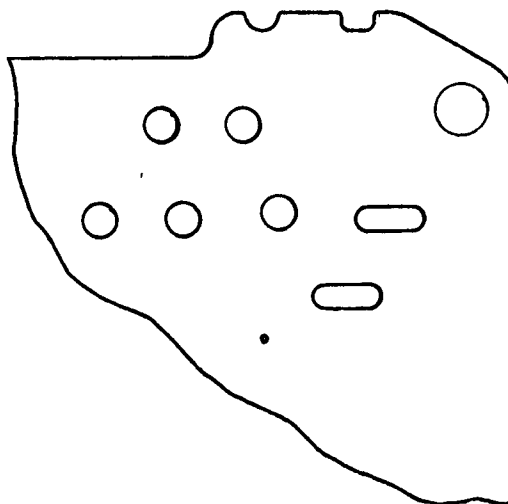

Figure 6A



Technical Service Information

SPACER PLATES WILL NOT INTERCHANGE FROM MODEL TO MODEL



THIS SPACER PLATE FITS "ONLY" THE 10 CHECKBALL OIL PUMP.

Figure 7



Technical Service Information

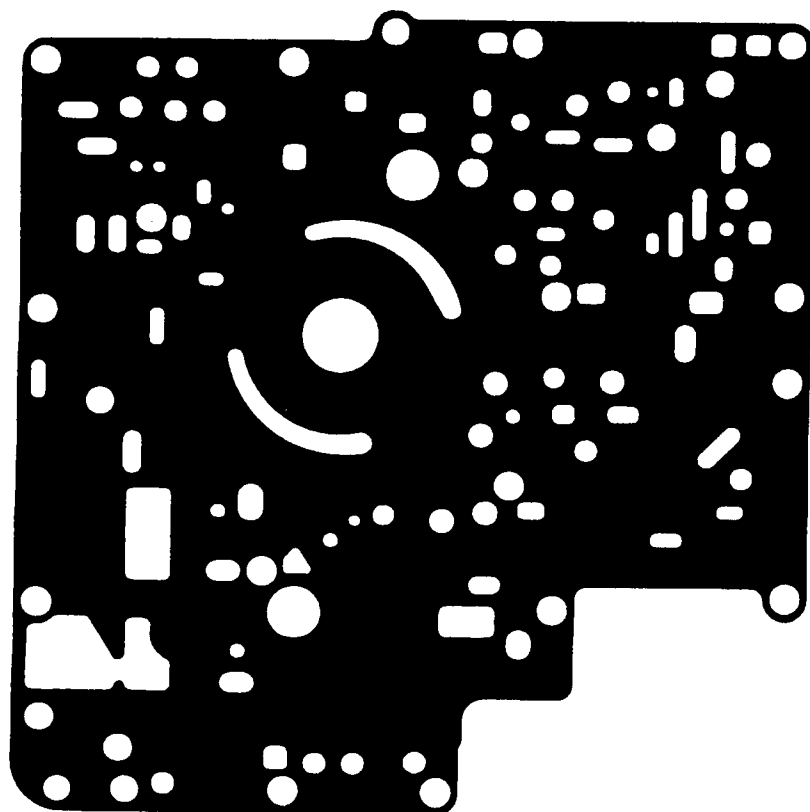

1986 PUMP SPACER PLATE
TO VALVE BODY.
E6DZ-7A136-A
(NO I.D. STRIPE)

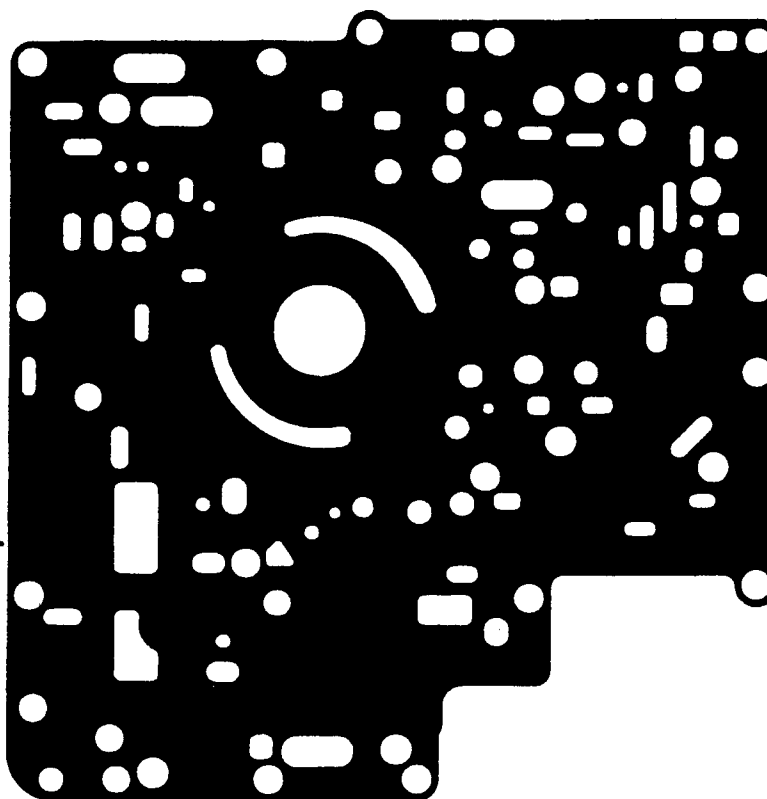

1986 PUMP BODY TO
PUMP SPACER PLATE
E6DZ-7G331-A
(NO I.D. STRIPE)

Figure 8



Technical Service Information

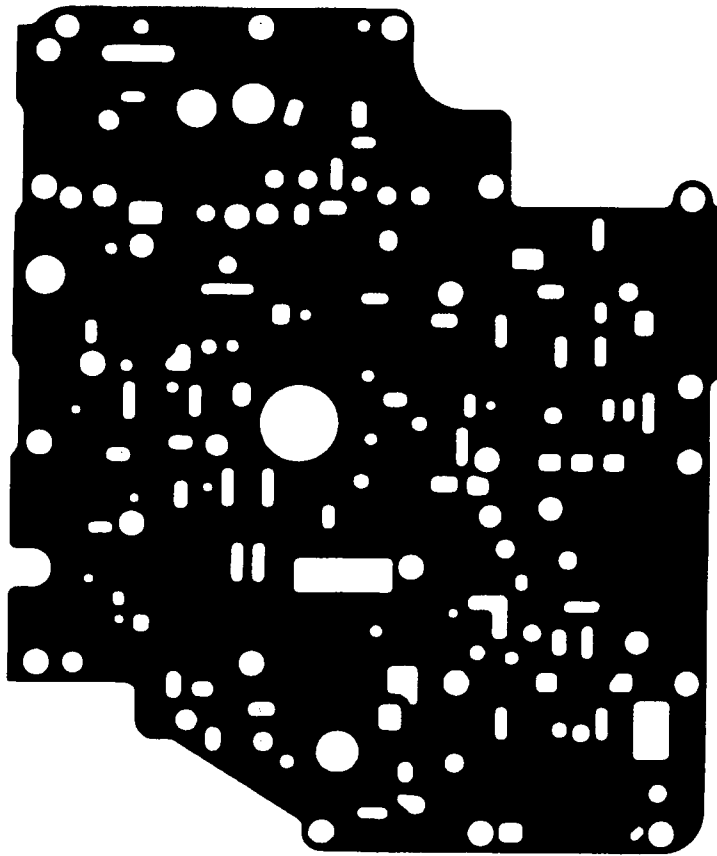

1986 VALVE BODY SPACER
PLATE TO CHAIN COVER
E6DZ-7C155-A
(NO I.D. STRIPE)

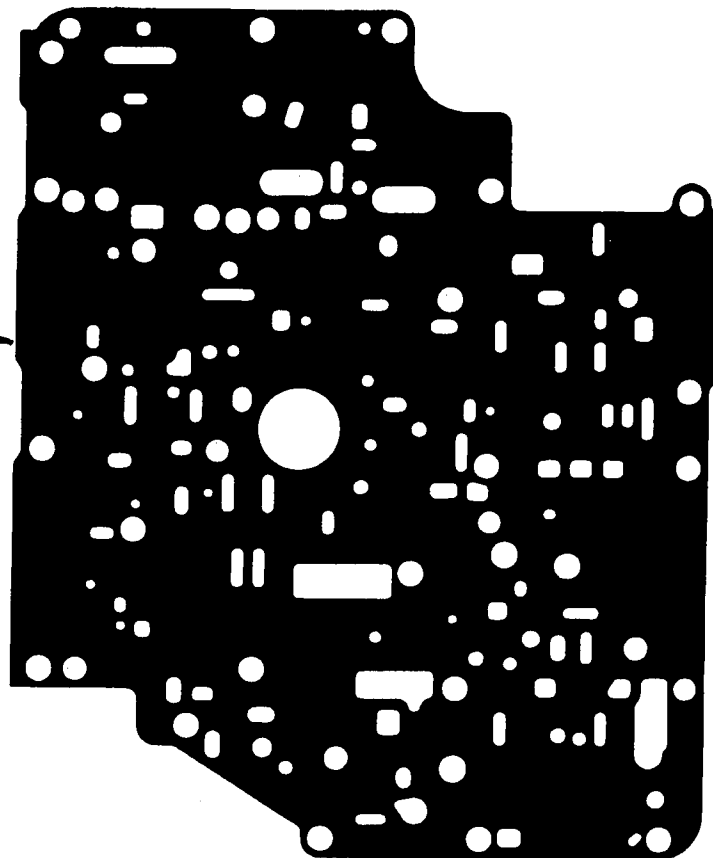

1986 VALVE BODY TO VALVE
BODY SPACER PLATE
E6DZ-7D100-A
(NO I.D. STRIPE)

Figure 9



Technical Service Information

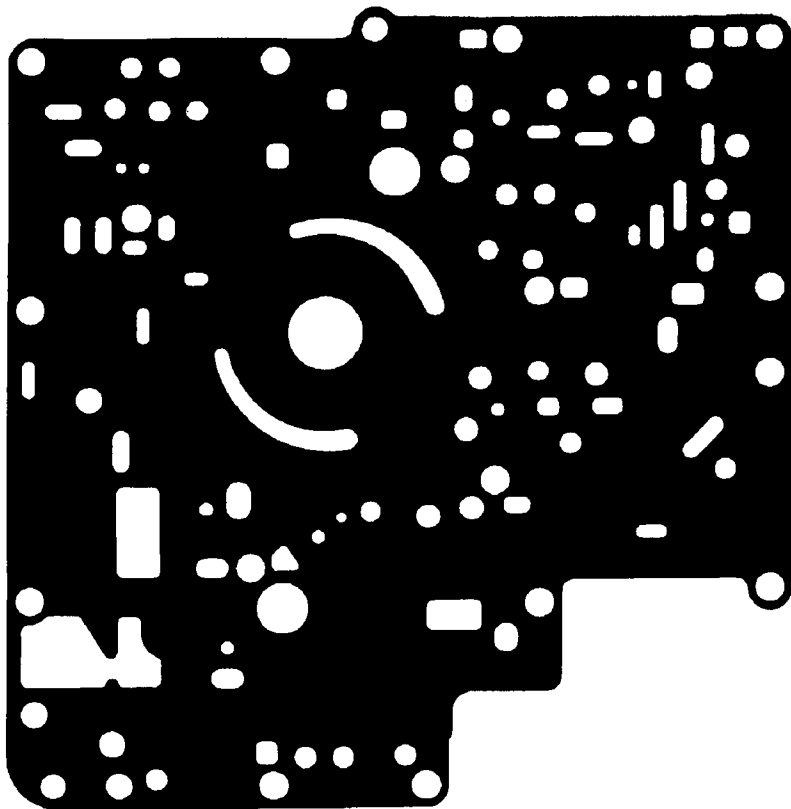

1987 PUMP SPACER PLATE
TO VALVE BODY
E7DZ-7A136-A
(WHITE I.D. STRIPE)

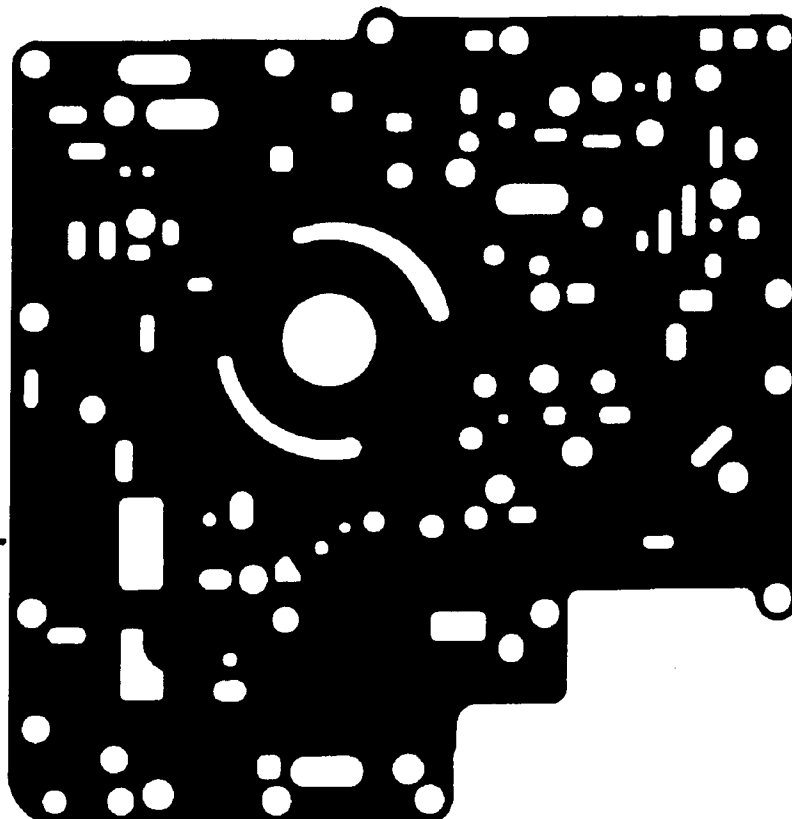

1987 PUMP BODY TO
PUMP SPACER PLATE
E7DZ-7G331-A
(WHITE I.D. STRIPE)

Figure 10
AUTOMATIC TRANSMISSION SERVICE GROUP
16



Technical Service Information

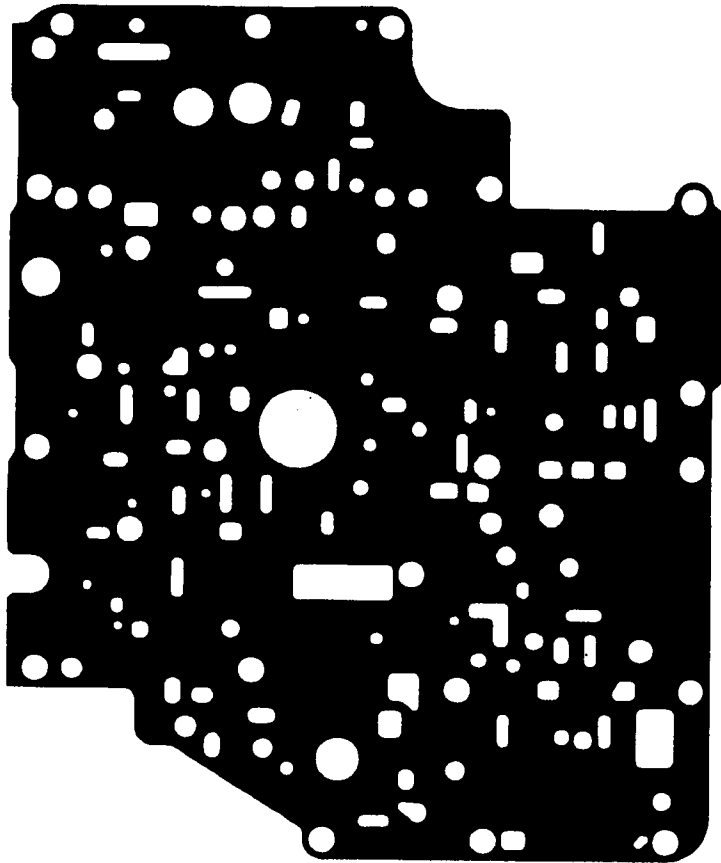

1987 VALVE BODY SPACER
PLATE TO CHAIN COVER
(E7DZ-7C155-A)
(WHITE I.D. STRIPE)

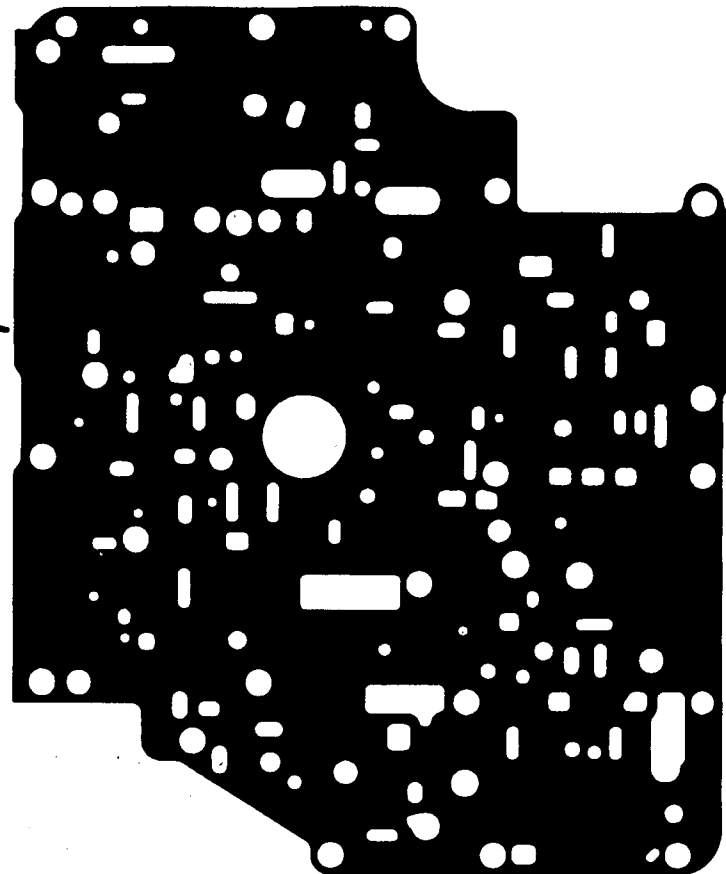

1987 VALVE BODY TO VALVE
BODY SPACER PLATE
E7DZ-7D100-A
(WHITE I.D. STRIPE)

Figure 11
AUTOMATIC TRANSMISSION SERVICE GROUP



Technical Service Information

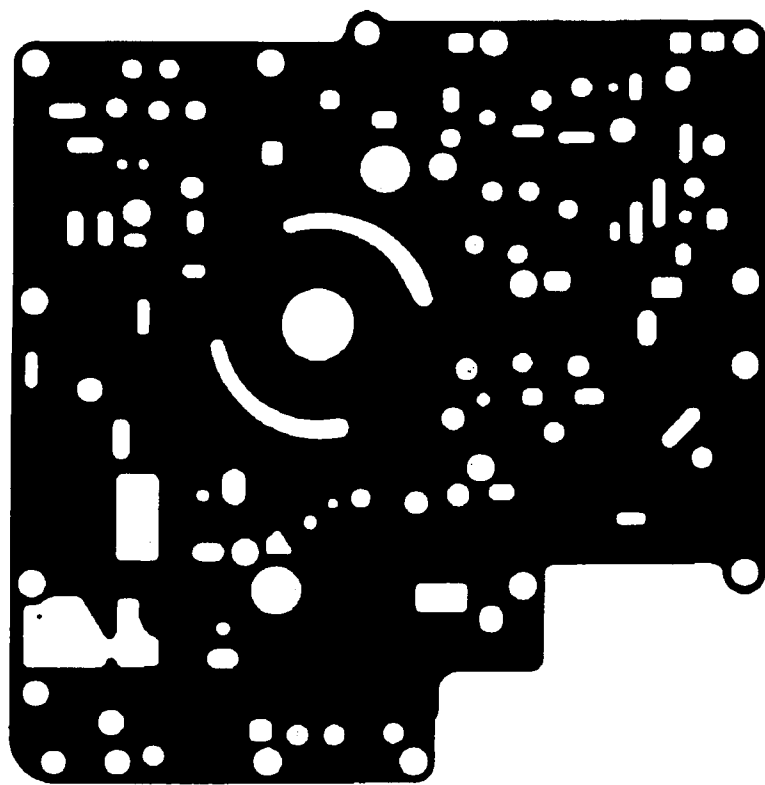

88/89 PUMP SPACER PLATE
TO VALVE BODY
E8DZ-7A136-A
(YELLOW I.D. STRIPE)

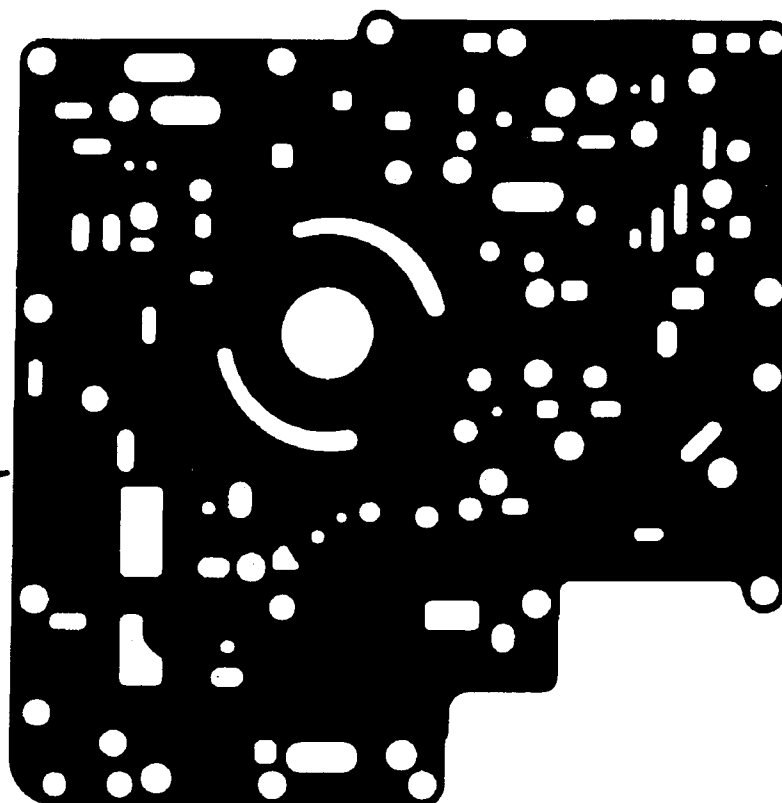

88/89 PUMP BODY TO
PUMP SPACER PLATE
E8DZ-7G331-A
(YELLOW I.D. STRIPE)

Figure 12
AUTOMATIC TRANSMISSION SERVICE GROUP



Technical Service Information

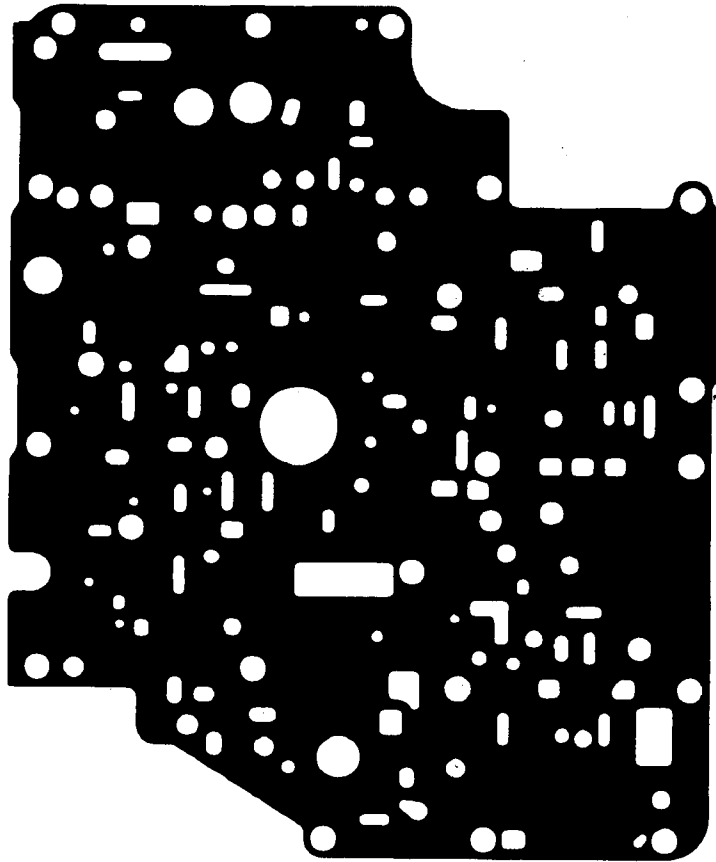

88/90 VALVE BODY SPACER
PLATE TO CHAIN COVER
E8DZ-7C155-A
(YELLOW I.D. STRIPE)

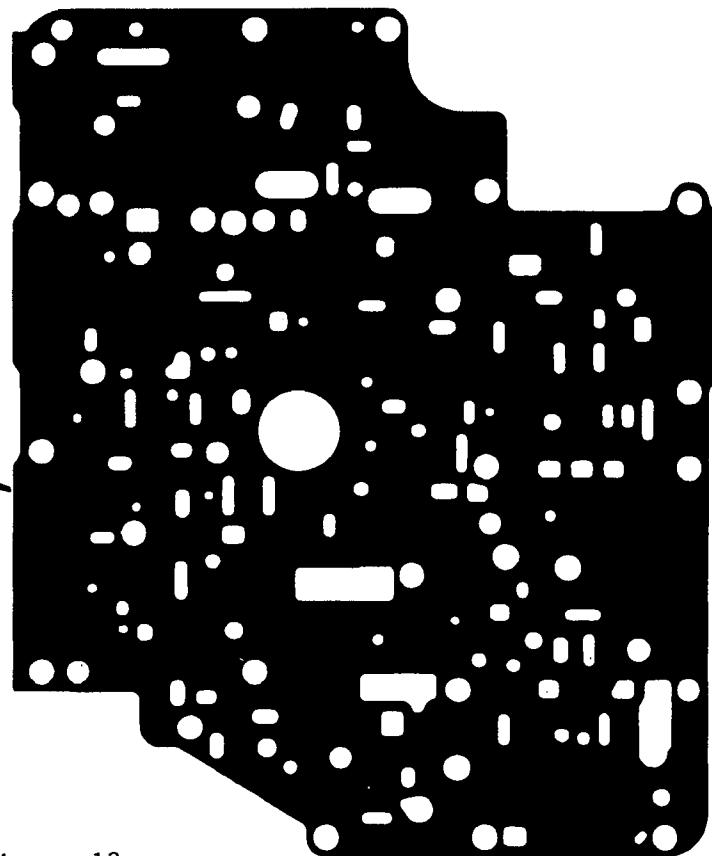

88/90 VALVE BODY TO VALVE
BODY SPACER PLATE
E8DZ-7D100-A
(YELLOW I.D. STRIPE)

Figure 13
AUTOMATIC TRANSMISSION SERVICE GROUP
19



Technical Service Information

10 CHECKBALL PUMP GASKETS

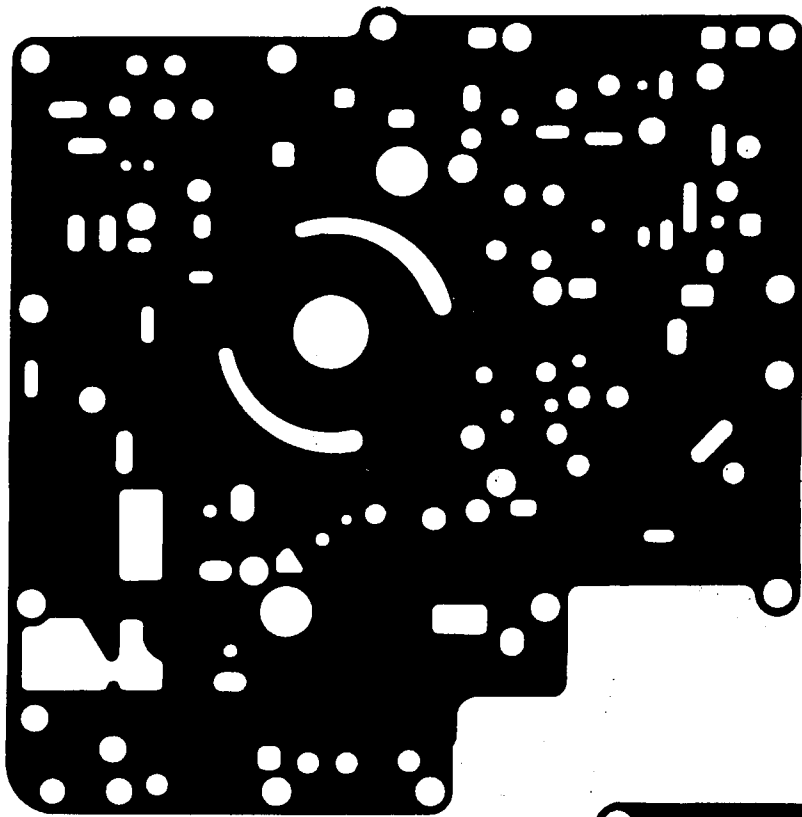

PUMP SPACER PLATE
TO VALVE BODY
E90Y-7A136-A
(BLUE I.D. STRIPE)

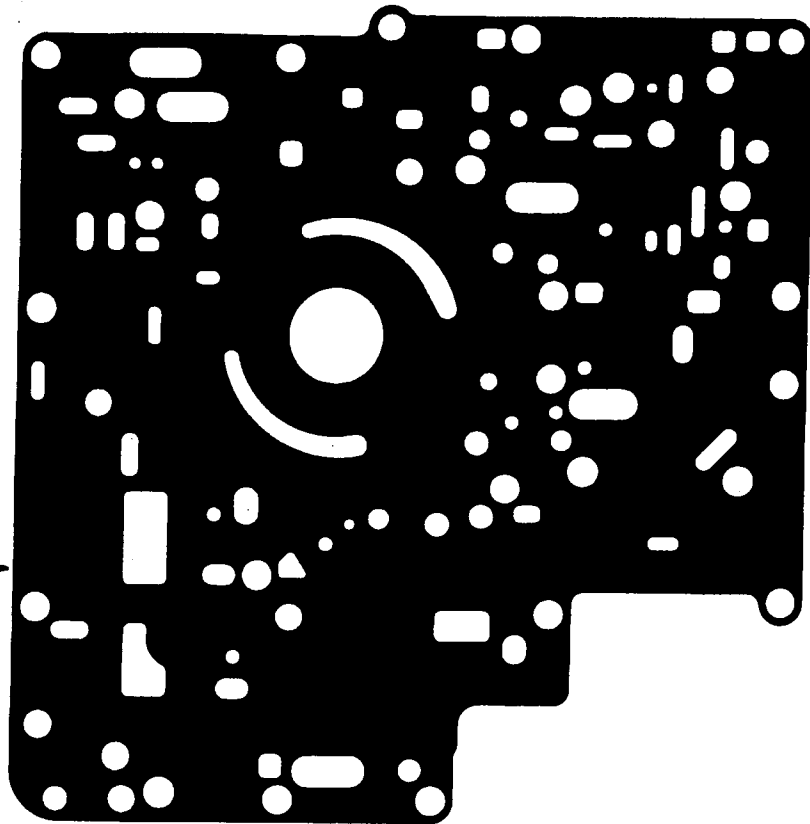

PUMP BODY TO
PUMP SPACER PLATE
E90Y-7G331-A
(BLUE I.D. STRIPE)

Figure 14



Technical Service Information

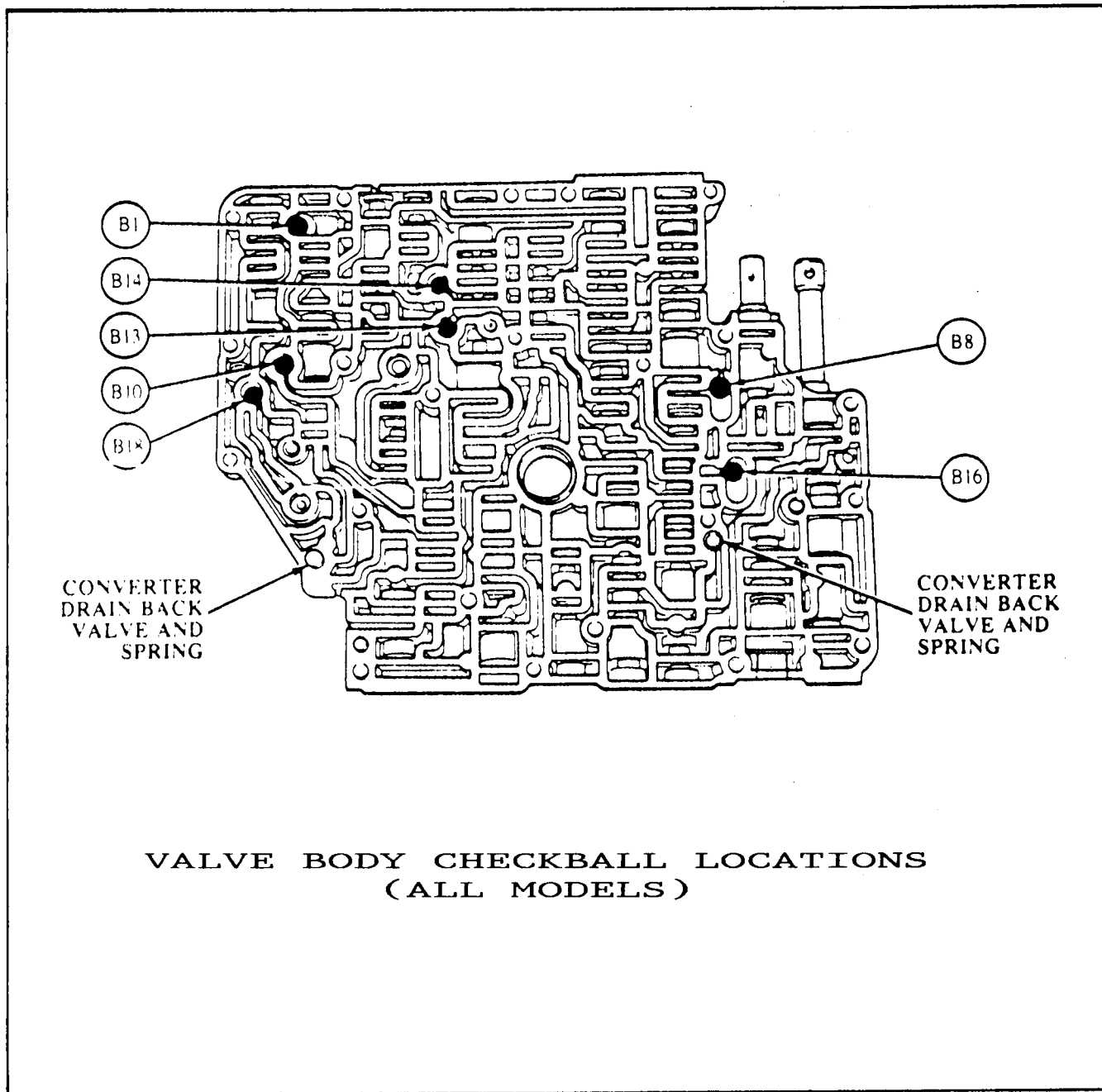

Figure 15



Technical Service Information

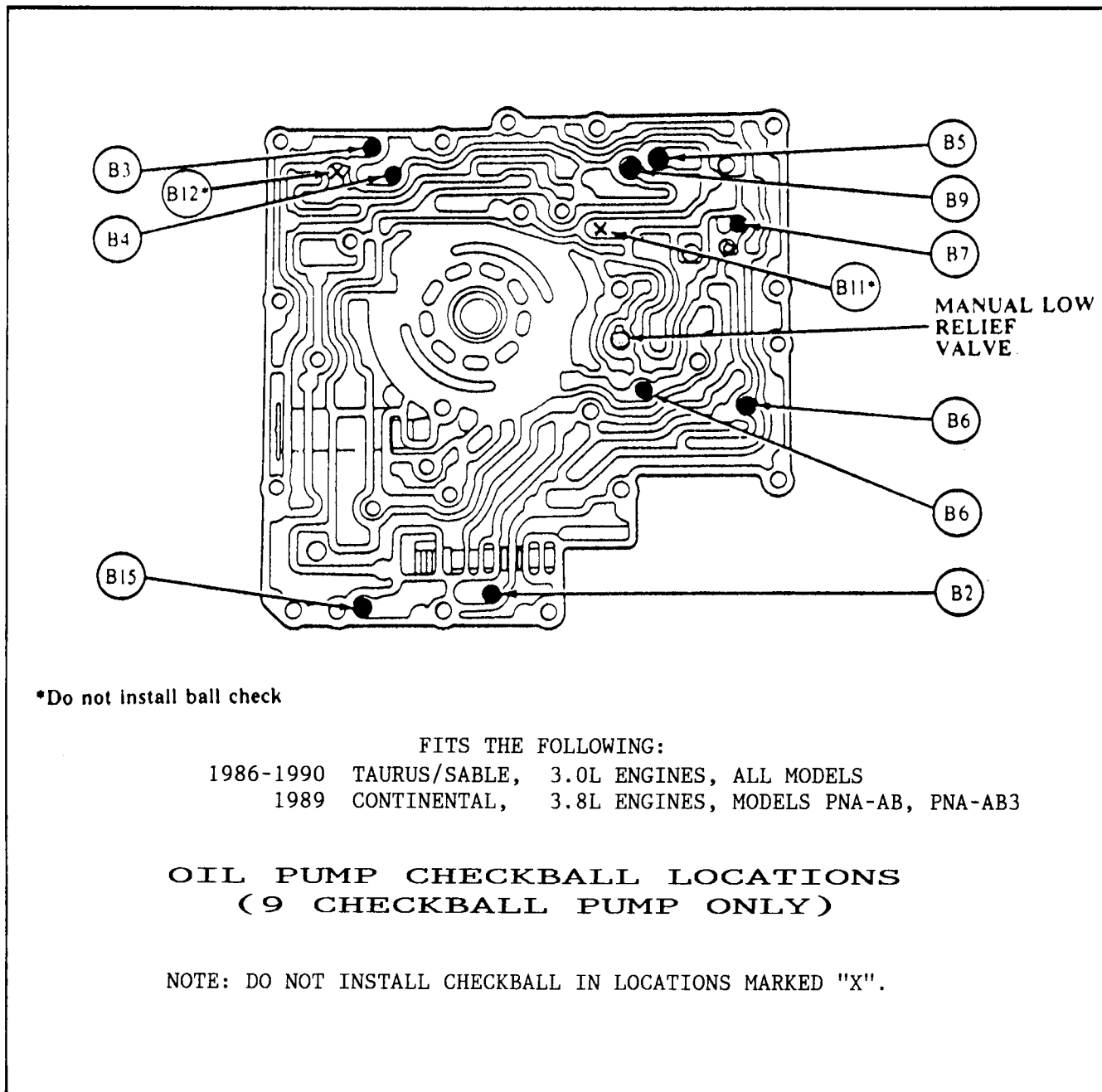
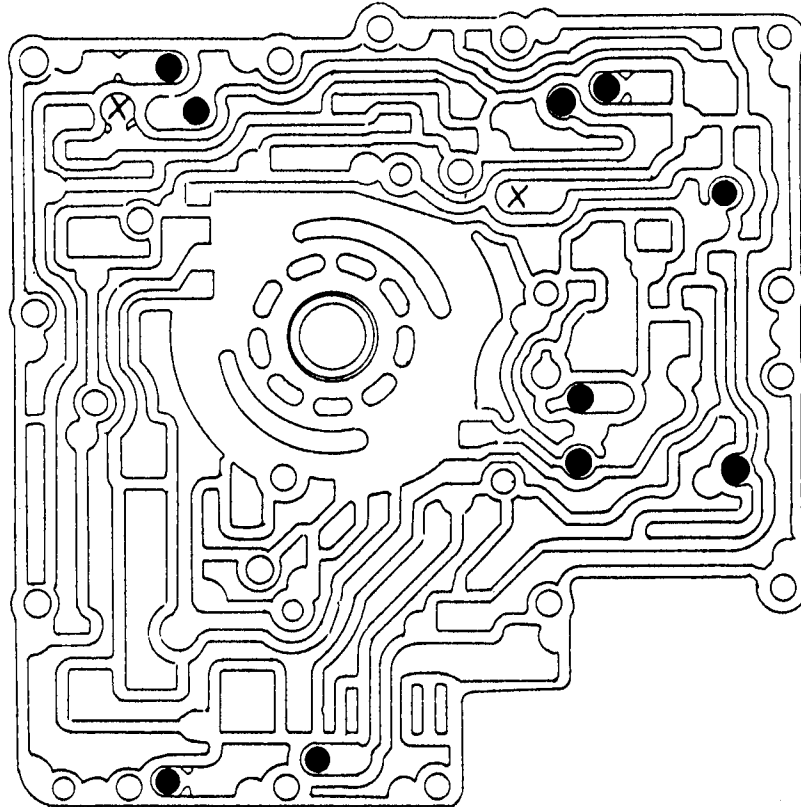

Figure 16



Technical Service Information



FITS THE FOLLOWING:

- 1989 CONTINENTAL, 3.8L ENGINES, MODELS PNA-AB4
- 1990 CONTINENTAL, 3.8L ENGINES, ALL MODELS
- 1990 TAURUS/SABLE, 3.8L ENGINES, ALL MODELS

**OIL PUMP CHECKBALL LOCATIONS
(10 CHECKBALL PUMP ONLY)**

NOTE: DO NOT INSTALL CHECKBALL IN LOCATIONS MARKED "X".

Figure 17



Technical Service Information

FORD AXOD

SOFT 1-2 AND/OR 2-3 SHIFTS

COMPLAINT: Soft or mushy 1-2 shift and/or 2-3 shift.

CAUSE: The cause may be a lack of oil volume to the intermediate and/or direct clutch packs.

CORRECTION: FOR SOFT 1-2 SHIFT:
Replace the 1-2 capacity modulator valve spring with the Red spring manufactured by Shift Technology Products (Part #K006). The kit also comes with a new style bore plug retaining clip. Assemble into the oil pump as shown in Figure 18. This modification should be made on all AXOD'S during rebuild.

NOTE: Do not install the valve backwards, as the result will be a one-neutral shift.

FOR SOFT 2-3 SHIFT:
Drill the direct clutch feed passage in the oil pump spacer plate, hole marked "I", out to .093" as shown in Figure 19.

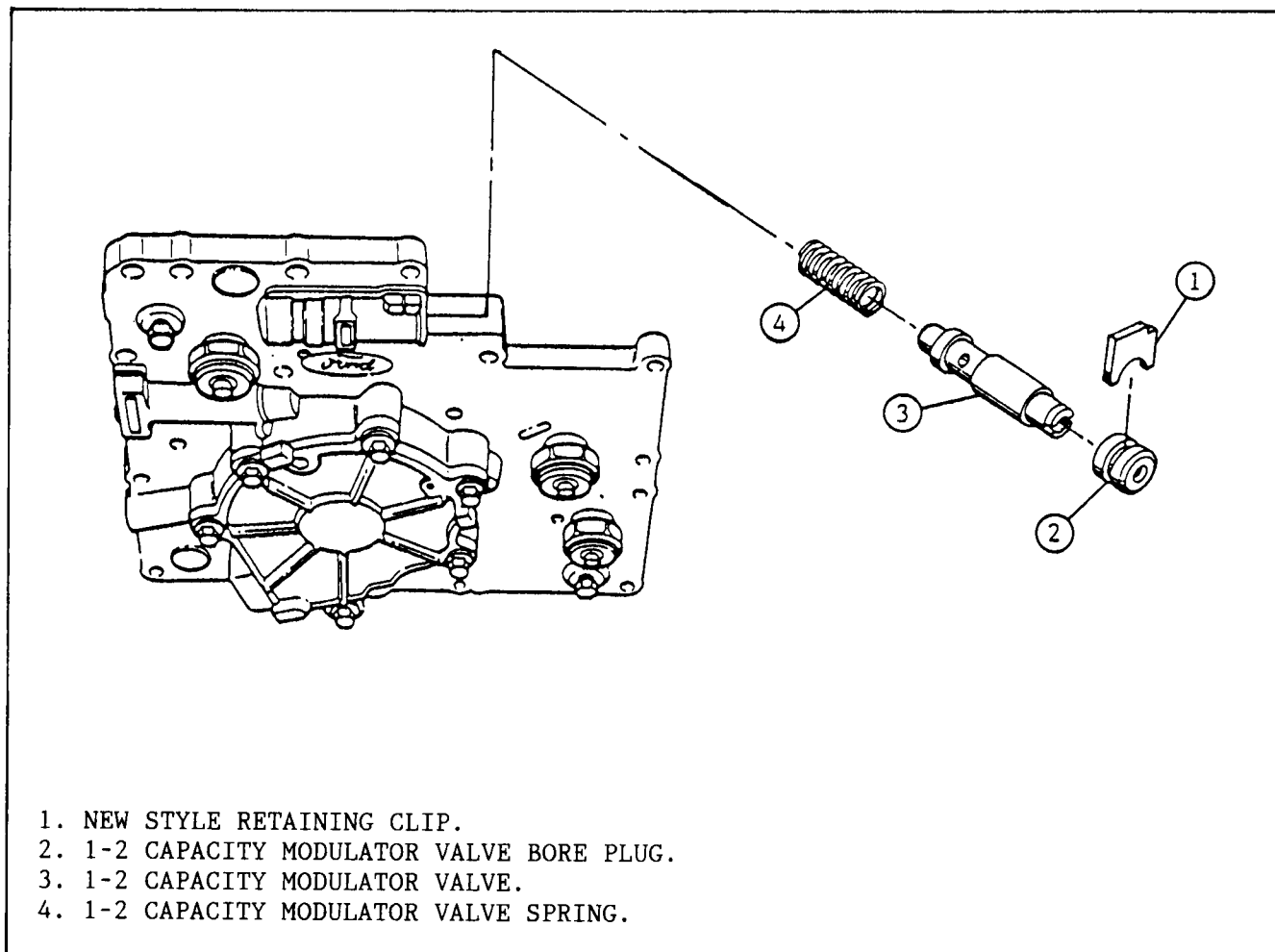

Figure 18



Technical Service Information

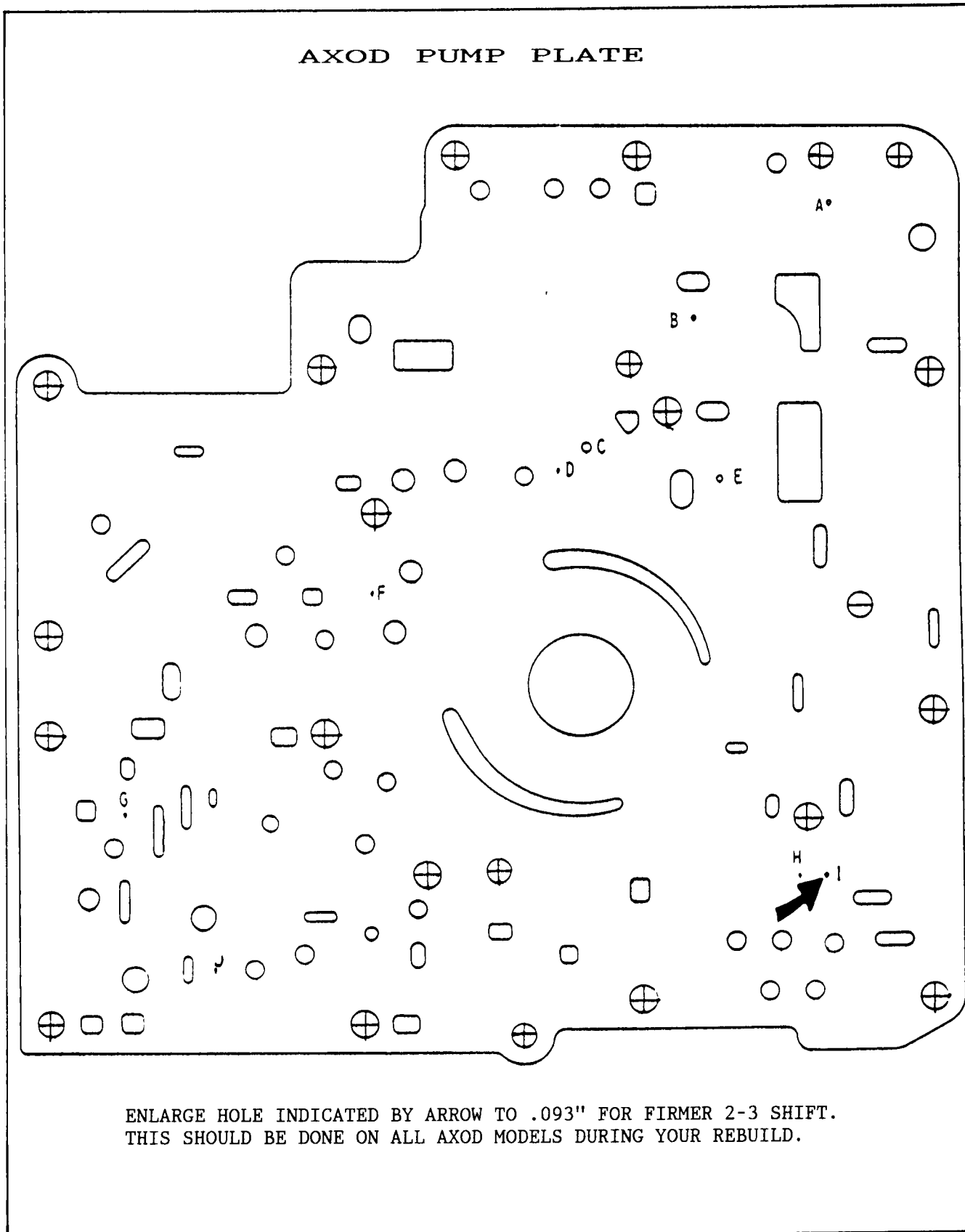
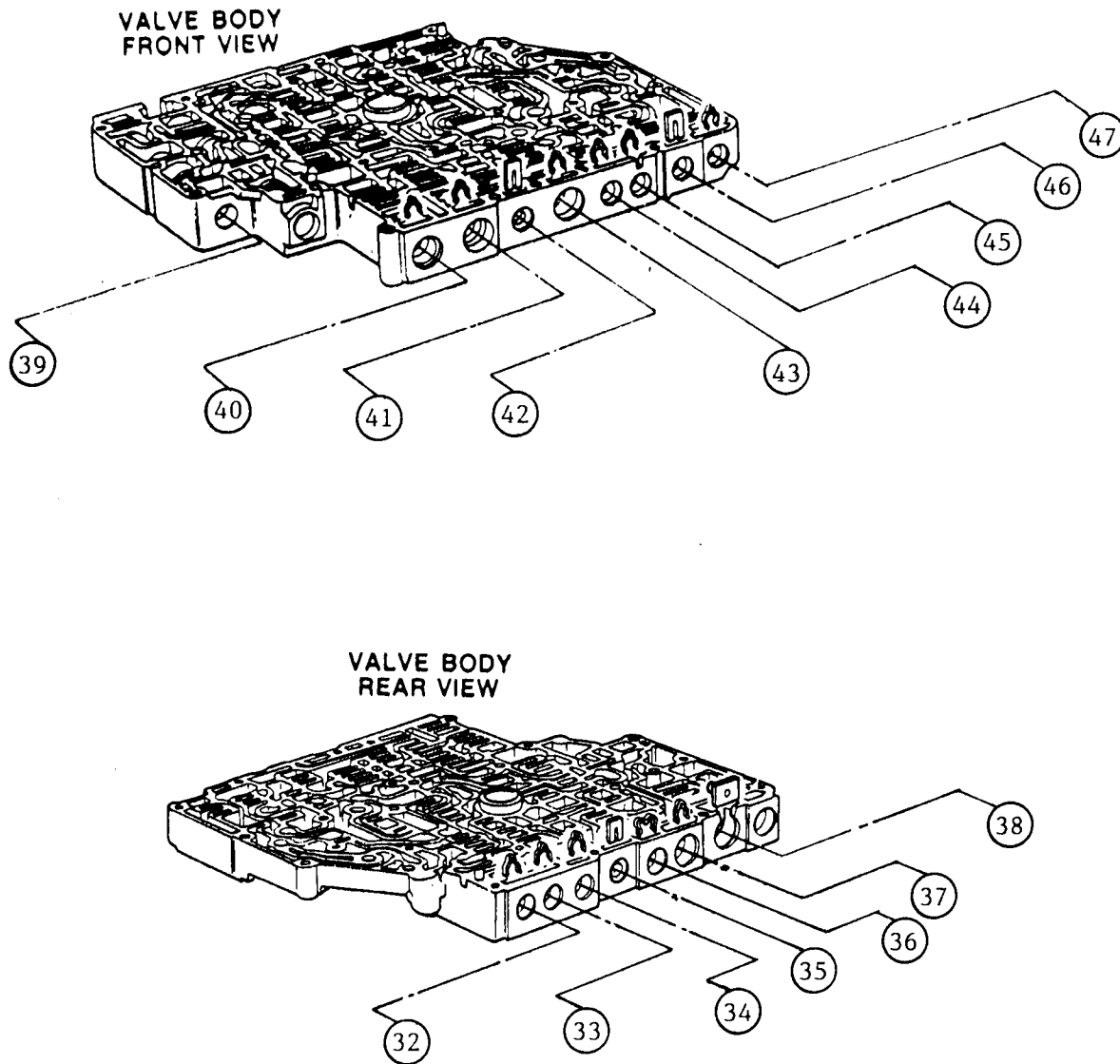

Figure 19



Technical Service Information

AXOD VALVE BODY BORE NUMBERS
AND VALVE IDENTIFICATION



ON THIS PAGE WE HAVE ASSIGNED NUMBERS TO ALL OF THE VALVE BODY BORES AND RE-DRAWN THE VALVES AND SPRINGS IN THEIR PROPER LOCATIONS, WITH EACH VALVE ORIENTED PROPERLY, AND IDENTIFIED, AS SHOWN ON THE FOLLOWING PAGES. "ALL" OF THE MANUALS PRESENTLY IN PRINT ARE WRONG.

USE THIS MANUAL TO PROPERLY ASSEMBLE THE AXOD VALVE BODY.

Figure 20

AUTOMATIC TRANSMISSION SERVICE GROUP



Technical Service Information

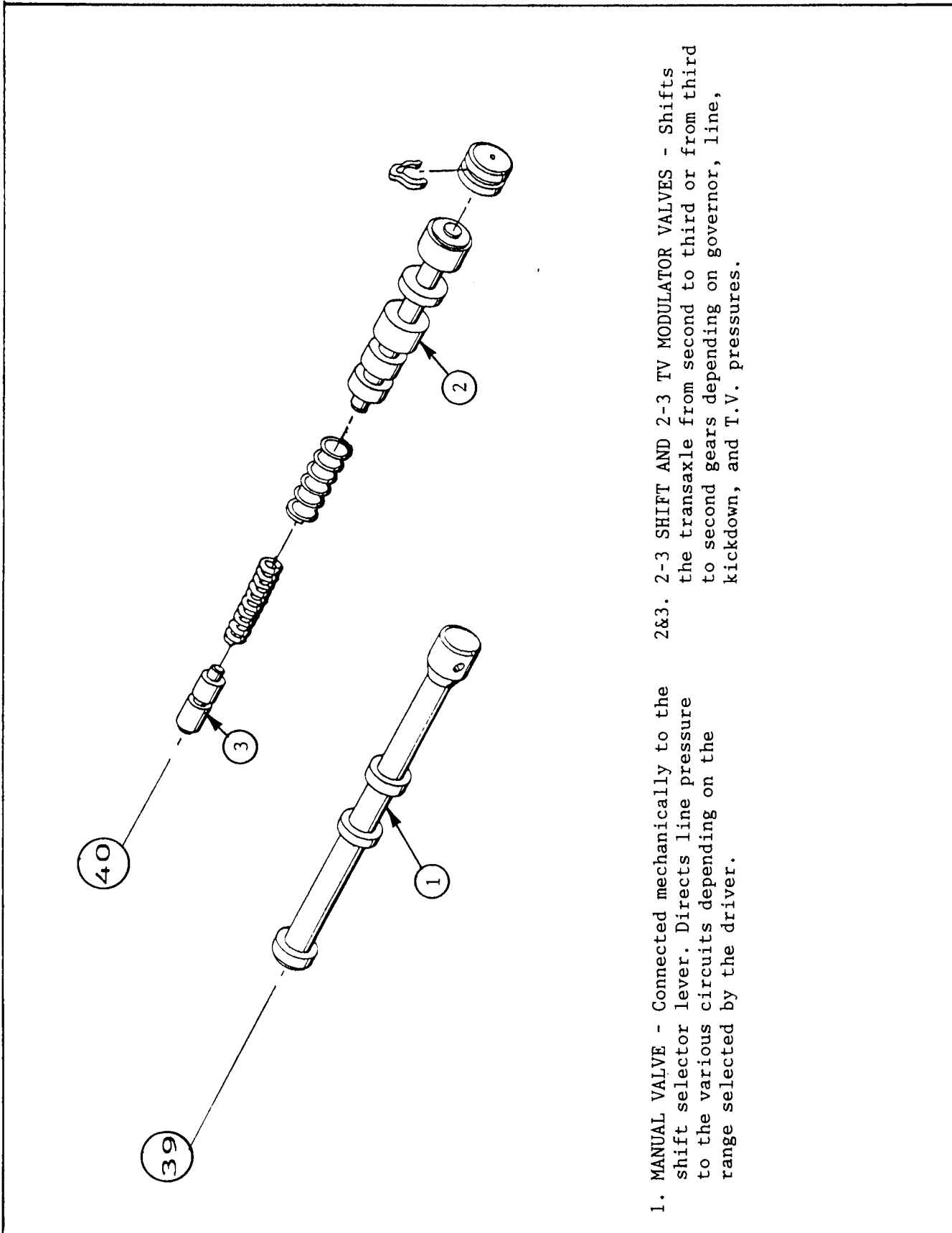

1. MANUAL VALVE - Connected mechanically to the shift selector lever. Directs line pressure to the various circuits depending on the range selected by the driver.

2&3. 2-3 SHIFT AND 2-3 TV MODULATOR VALVES - Shifts the transaxle from second to third or from third to second gears depending on governor, line, kickdown, and T.V. pressures.

Figure 21

AUTOMATIC TRANSMISSION SERVICE GROUP



Technical Service Information

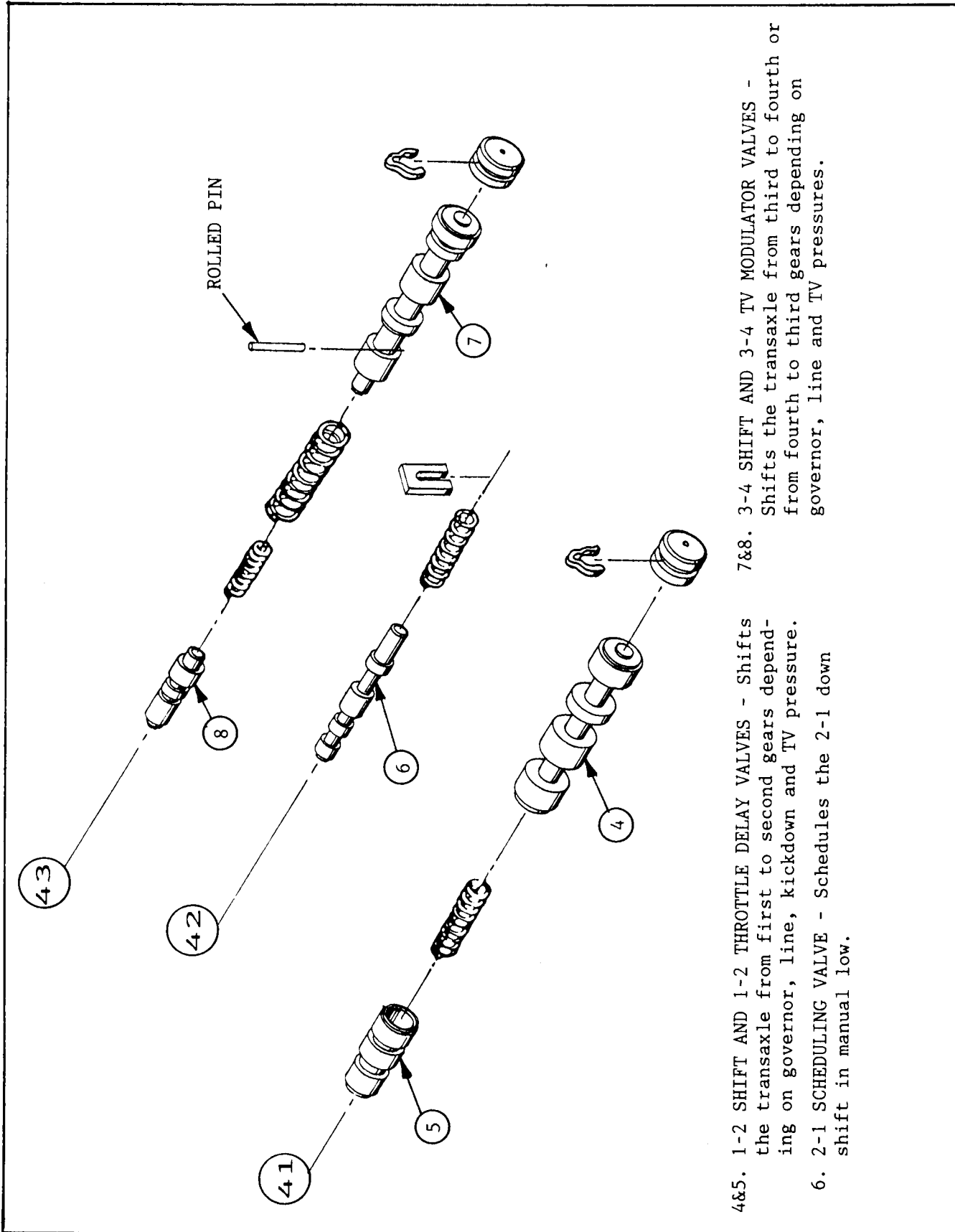

4&5. 1-2 SHIFT AND 1-2 THROTTLE DELAY VALVES - Shifts the transaxle from first to second gears depending on governor, line, kickdown and TV pressure.

6. 2-1 SCHEDULING VALVE - Schedules the 2-1 down shift in manual low.

7&8. 3-4 SHIFT AND 3-4 TV MODULATOR VALVES - Shifts the transaxle from third to fourth or from fourth to third gears depending on governor, line and TV pressures.

Figure 22

AUTOMATIC TRANSMISSION SERVICE GROUP



Technical Service Information

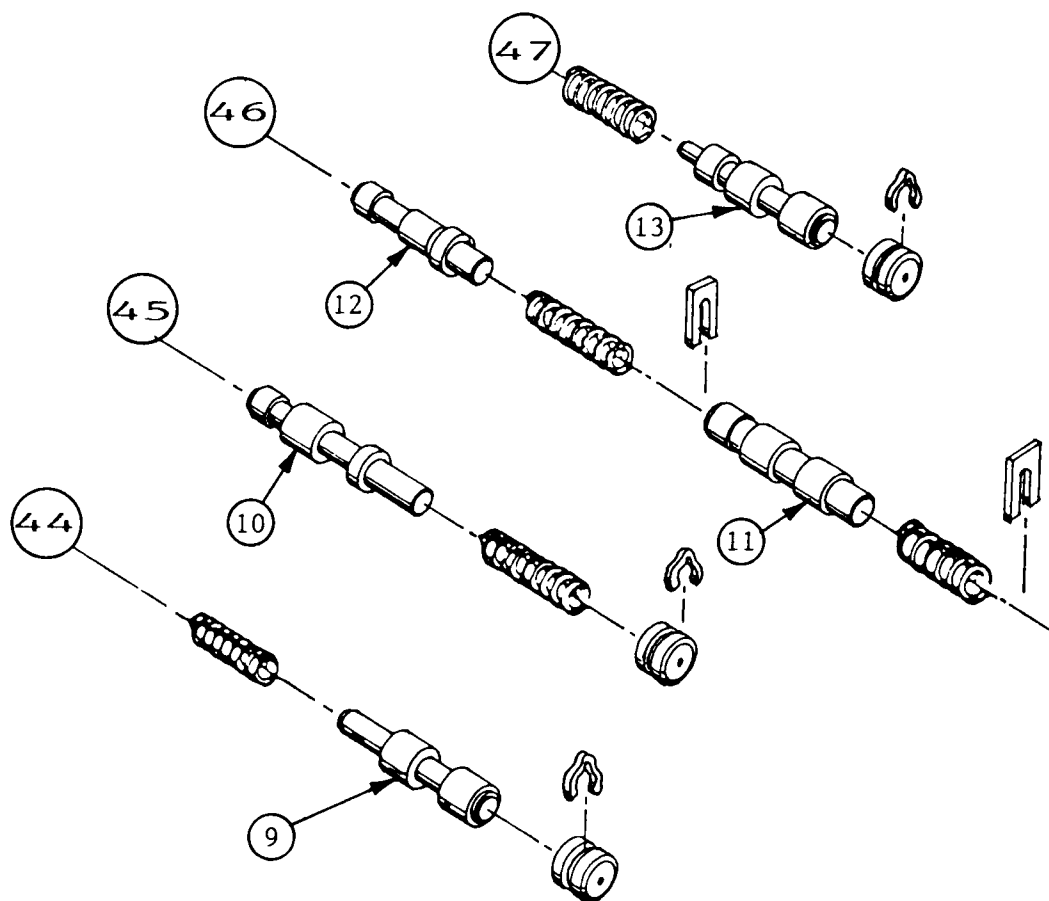

- | | |
|---|--|
| <p>9. 2-4 INHIBIT VALVE - Prevents a 2-4 upshift by directing line pressure to hold the 3-4 shift valve in the down shifted position whenever the direct clutch circuit is not pressurized.</p> <p>10. 3-2 CONTROL VALVE - Controlled by governor pressure, and controls the timing of the 3-2 downshift by regulating the rate at which the direct clutch releases and the 1-2 band applies.</p> | <p>11. TV LIMIT VALVE - Limits TV pressure to a maximum of 82-87 PSI.</p> <p>12. N/D ENGAGEMENT VALVE - Controls the orifices used to apply the 1-2 band for a N/D engagement by absorbing some of the apply oil during the engagement.</p> <p>13. 2-3 SERVO REGULATOR VALVE - Regulates 1-2 servo apply pressure controlling the action of 1-2 servo release as an accumulator for the 2-3 shift.</p> |
|---|--|

Figure 23
AUTOMATIC TRANSMISSION SERVICE GROUP



Technical Service Information

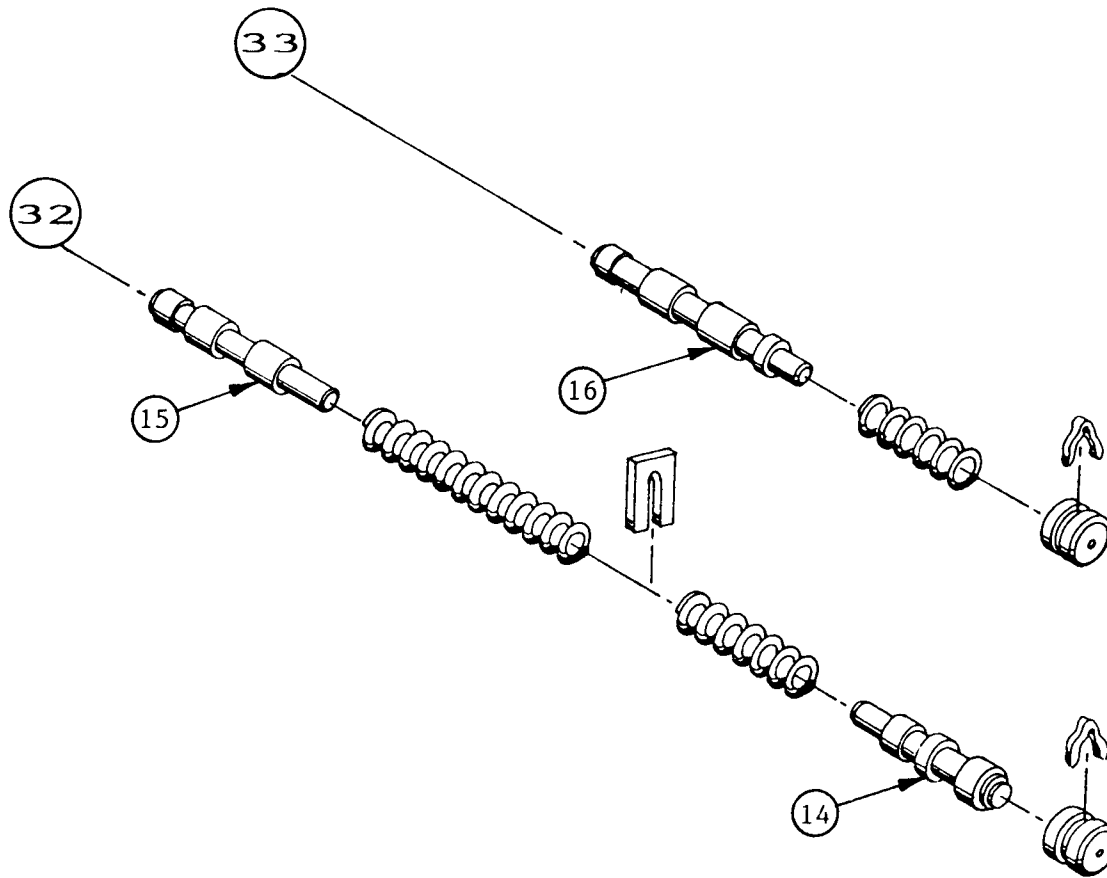

- 14. TV/LINE MODULATOR VALVE - Modifies TV pressure for control of line pressure to more closely match engine torque and transaxle capacity requirements.
- 15. 4-3 SCHEDULING VALVE - Prevents fourth gear operation at high TV pressure.
- 16. BACKOUT VALVE - Controls the orifices used for the 2-3 and 3-4 upshifts based on the backout signal from the manual valve. Also prevents a 3-2 downshift at closed throttle.

Figure 24

AUTOMATIC TRANSMISSION SERVICE GROUP



Technical Service Information

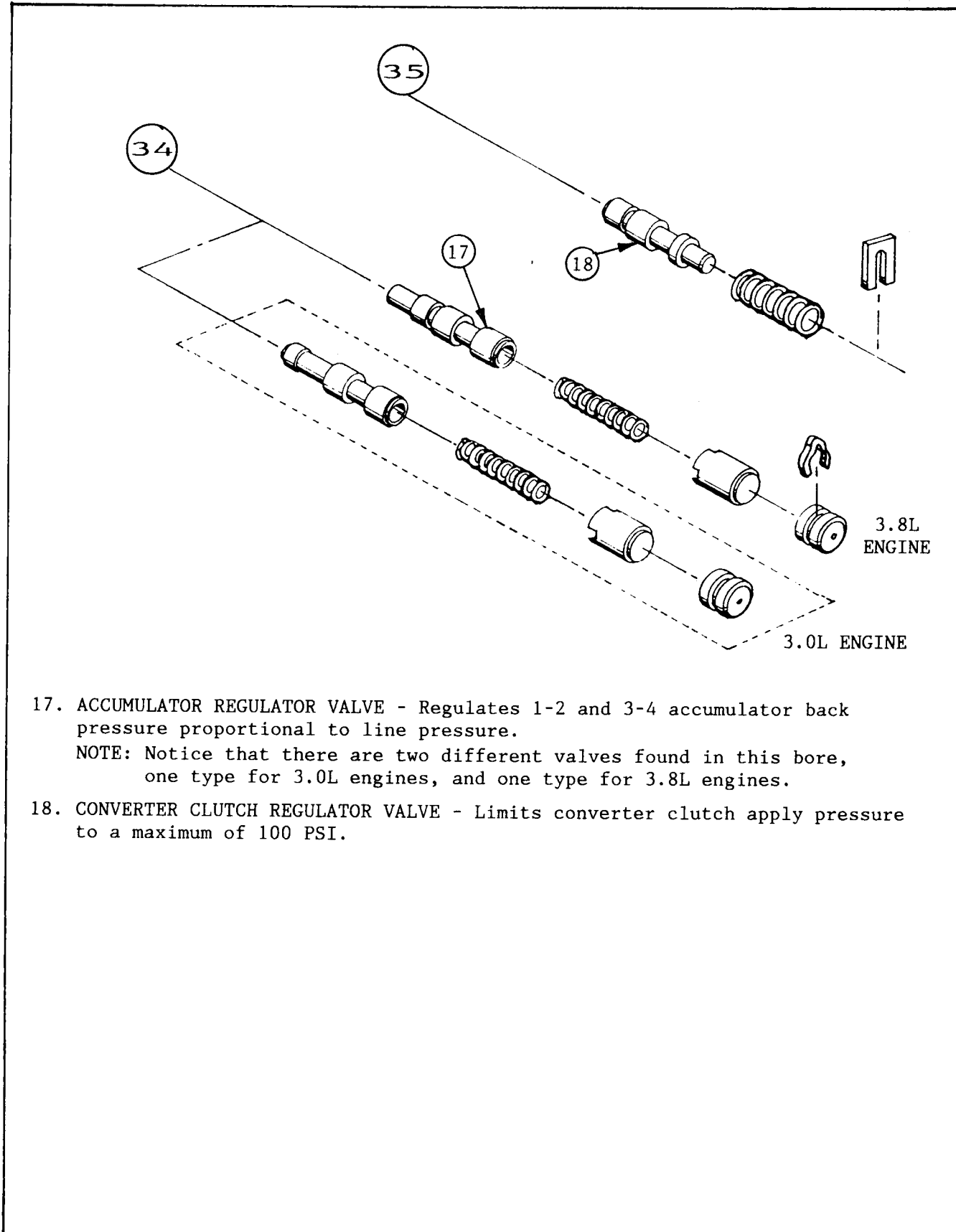

17. ACCUMULATOR REGULATOR VALVE - Regulates 1-2 and 3-4 accumulator back pressure proportional to line pressure.

NOTE: Notice that there are two different valves found in this bore, one type for 3.0L engines, and one type for 3.8L engines.

18. CONVERTER CLUTCH REGULATOR VALVE - Limits converter clutch apply pressure to a maximum of 100 PSI.

Figure 25



Technical Service Information

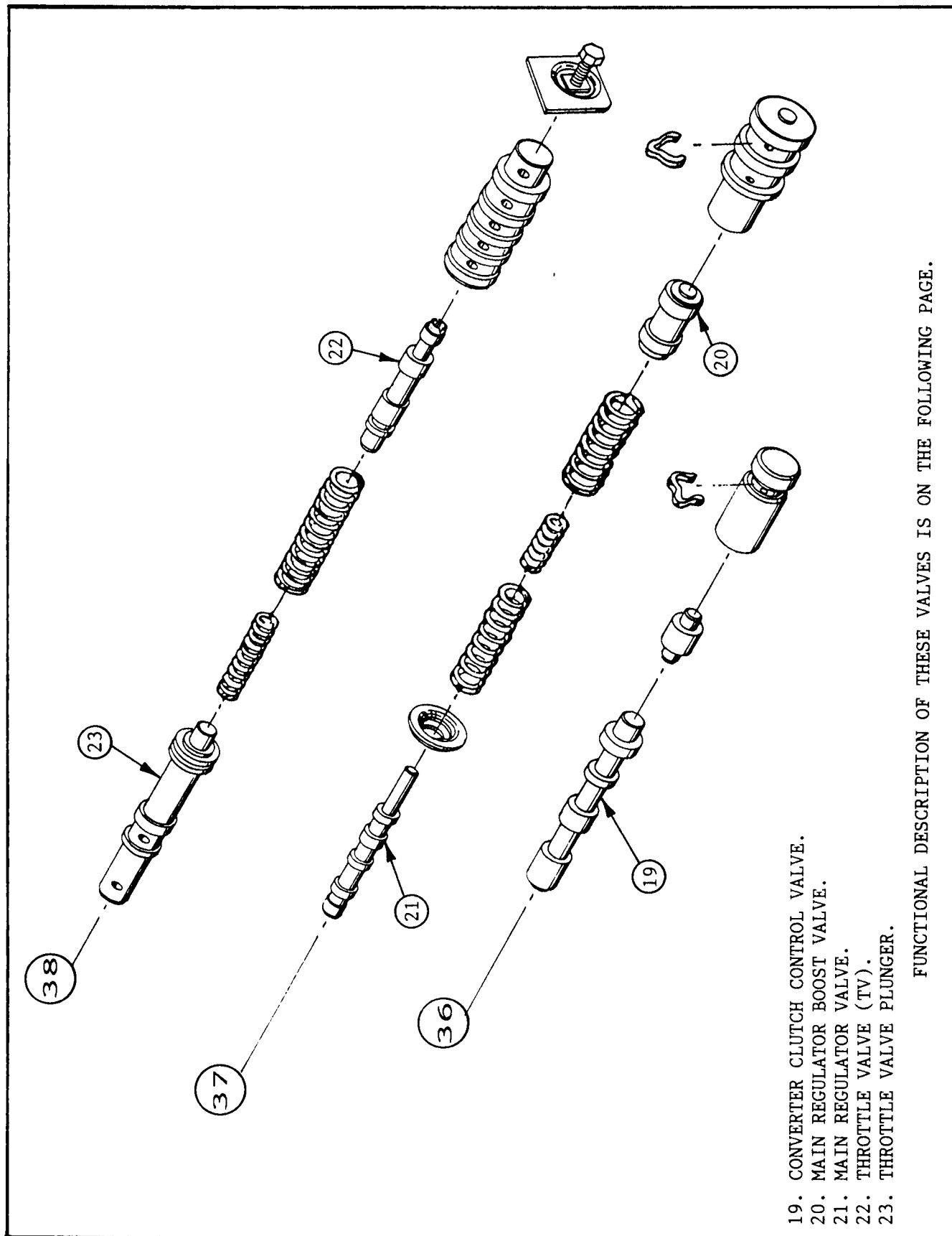

- 19. CONVERTER CLUTCH CONTROL VALVE.
- 20. MAIN REGULATOR BOOST VALVE.
- 21. MAIN REGULATOR VALVE.
- 22. THROTTLE VALVE (TV).
- 23. THROTTLE VALVE PLUNGER.

FUNCTIONAL DESCRIPTION OF THESE VALVES IS ON THE FOLLOWING PAGE.

FIGURE 26

AUTOMATIC TRANSMISSION SERVICE GROUP



Technical Service Information

19. CONVERTER CLUTCH CONTROL VALVE - Exhausts or pressurizes the converter clutch circuit to apply or release the clutch based on the state of converter clutch solenoid pressure (Signal Oil). Regulates converter clutch pressure proportional to solenoid pressure during release of the converter clutch. Controls lube and cooler flow orifices based on the state of the converter clutch.
20. MAIN REGULATOR BOOST VALVE - Exerts a force on the main regulator valve controlling line pressure based on reverse and TV/Line modulator pressures.
21. MAIN REGULATOR VALVE - Regulates line pressure by controlling pump output. Controlled by cutback (L234) signal, spring preload, and the force exerted by the main regulator boost valve.
22. THROTTLE VALVE (TV) - Regulates TV pressure proportional to throttle plunger position, or throttle opening.
23. THROTTLE PLUNGER - Mechanically connected to the accelerator pedal, and as the pedal is depressed, the plunger compresses the TV plunger spring causing the throttle valve to increase TV pressure. The plunger position also controls the opening of the backout and kickdown ports.



Technical Service Information

FORD AXOD

PREMATURE PLANETARY FAILURE

SEVERAL MODIFICATIONS CAN BE MADE IN AN EFFORT TO HELP IMPROVE LUBE OIL FLOW TO THE PLANETARY SYSTEM AND THEY ARE AS FOLLOWS:

1. Drill the torque converter fill hole in the valve body spacer plate out to .062" (1/16 Inch). This is the hole marked "D" as shown in Figure 27.
Drill the rear lube orifice in the valve body spacer plate out to .078" (5/64 Inch). This is the hole marked "I" as shown in Figure 27.
2. Trim the rear lube check valve spring, which is located in the valve body, until the check valve sits approximately 1/16" above the machined surface of the valve body (See Figure 28). This will require approximately 3 coils be removed from the spring, and always install the cut end of the spring back into the valve body first.
3. Inspect the bushings in the rear planetary support, as these bushings can move out of position and block the lube oil hole located in the support between them. The 1988 and later rear planetary support has a new design, wider, one piece bushing with a groove and lube hole in the center. This will provide more surface area to prevent the bushing from moving. Refer to Figure 29.
The later rear planetary support, with the 2nd design bushing, will retro fit back to ALL previous models and is highly recommended. The new design rear planetary support is available under OEM part number E6DZ-7A130-A.
4. Replace the rear lube tube seal with the early design THM 200 (2 Piece) low/reverse support seal. Refer to Figure 30 for installation. The THM 200 two piece seal will now provide additional flexibility and still retain its ability to seal against the rear planetary support. The support CAN rotate in the case lugs, and when the support rotates it WILL damage the one piece seal.
This tip compliments of:
Kelleys Transmission
Albuquerque, NM
NOTE: WHENEVER THE REAR SUPPORT HAS BEEN REMOVED FOR ANY REASON, THE REAR LUBE TUBE SEAL MUST BE REPLACED.
5. Install "Double Bushings" at the rear of sun gear as shown in Figure 31. After both bushings are in place, ensure that lube oil hole in the sun gear is not blocked.



Technical Service Information

AXOD VALVE BODY PLATE

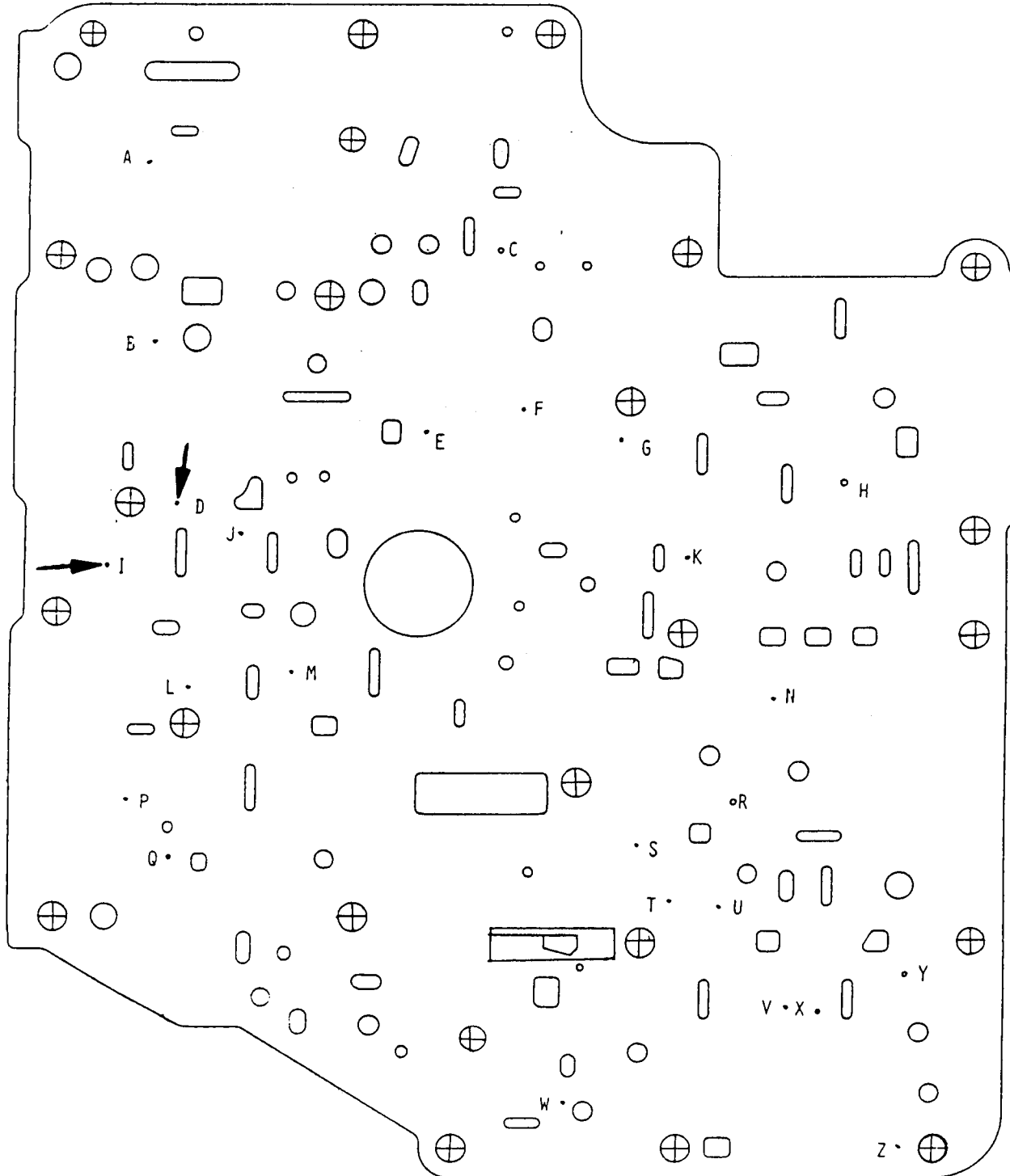

HOLE MARKED "D" - DRILL OUT TO .062" (1/16 INCH).
 HOLE MARKED "I" - DRILL OUT TO .078" (5/64 INCH).

Figure 27



Technical Service Information

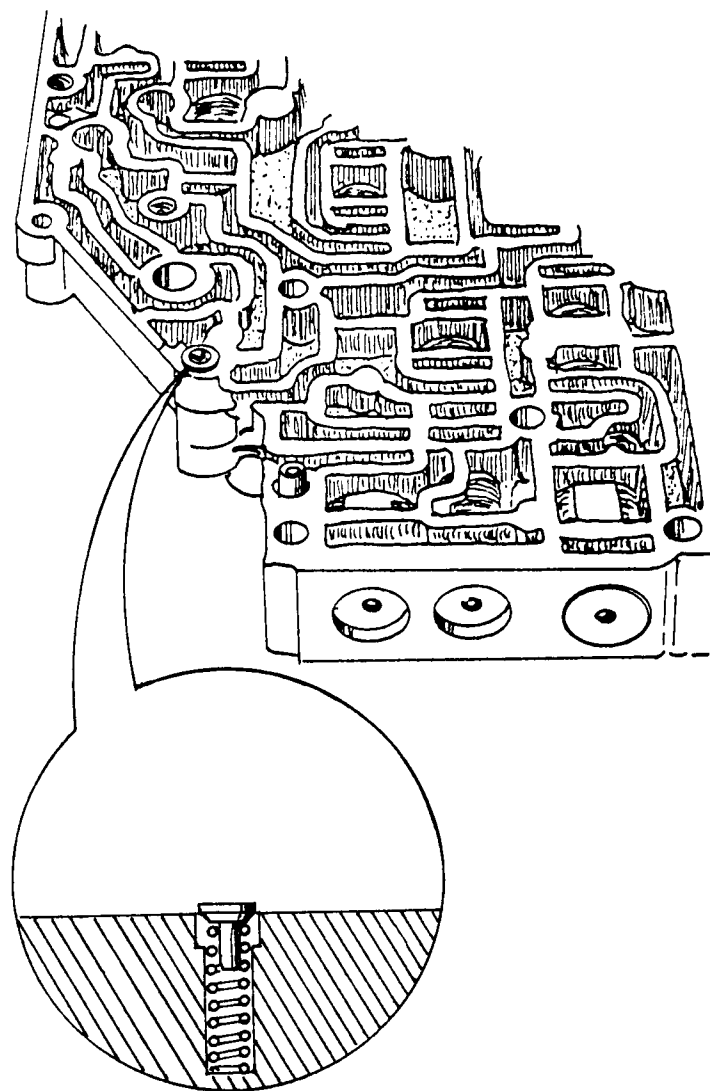

TRIM THE REAR LUBE CHECK VALVE SPRING, UNTIL THE CHECK VALVE SITS ABOUT 1/16" ABOVE THE MACHINED SURFACE OF VALVE BODY.

Figure 28



Technical Service Information

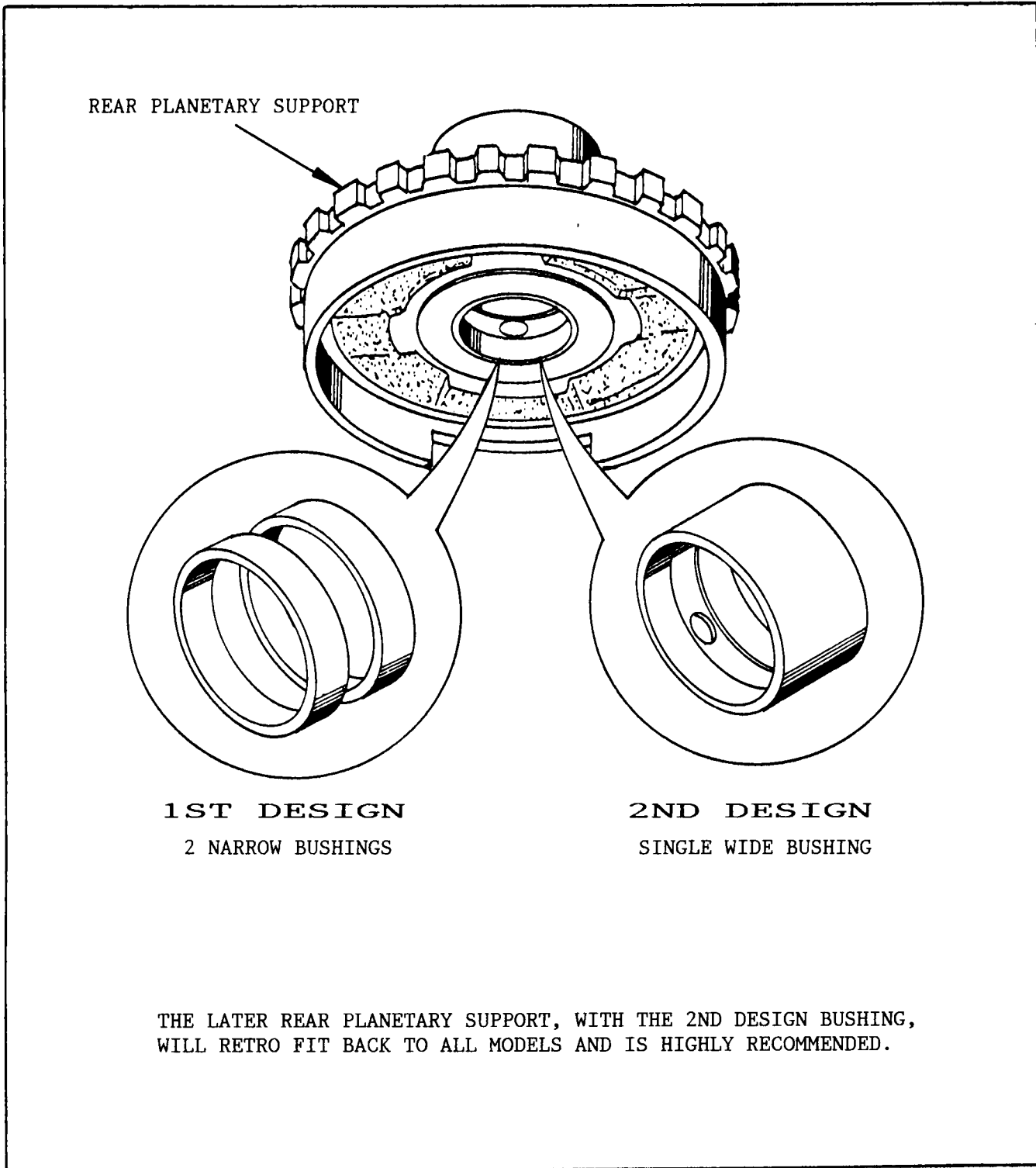
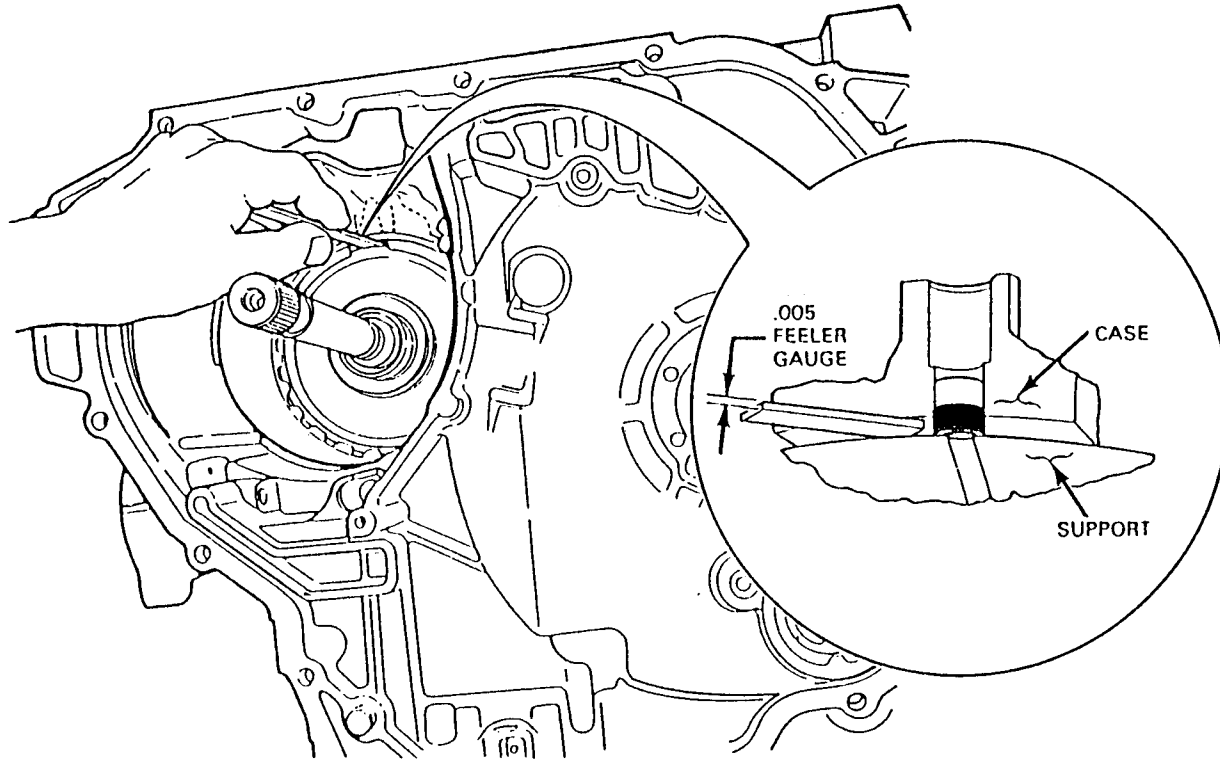

Figure 29



Technical Service Information



SLIDE A FEELER GAUGE (.005" OR LESS) BETWEEN THE CASE AND REAR SUPPORT, THROUGH THE OPENING IN THE SNAP RING TO MAKE SURE THE SEAL IS FULLY SEATED. THE SEAL MUST CONTACT AND BE FLUSH AGAINST THE REAR SUPPORT. IF THE FEELER GAUGE PASSES BETWEEN THE SEAL AND THE SUPPORT, DRIVE THE CUP PLUG FURTHER INTO THE CASE BORE AND CHECK AGAIN.

Figure 30



Technical Service Information

DOUBLE BUSHINGS IN SUN GEAR

PRESS ORIGINAL BUSHING DOWN FAR ENOUGH TO MAKE ROOM FOR THE NEW BUSHING WITHOUT COVERING LUBE OIL HOLE IN THE SUN GEAR.

INSTALL NEW BUSHING ON TOP OF THE ORIGINAL BUSHING.

THIS AREA SHOWN CUTAWAY

ENSURE THAT THIS LUBE HOLE IS NOT BLOCKED.

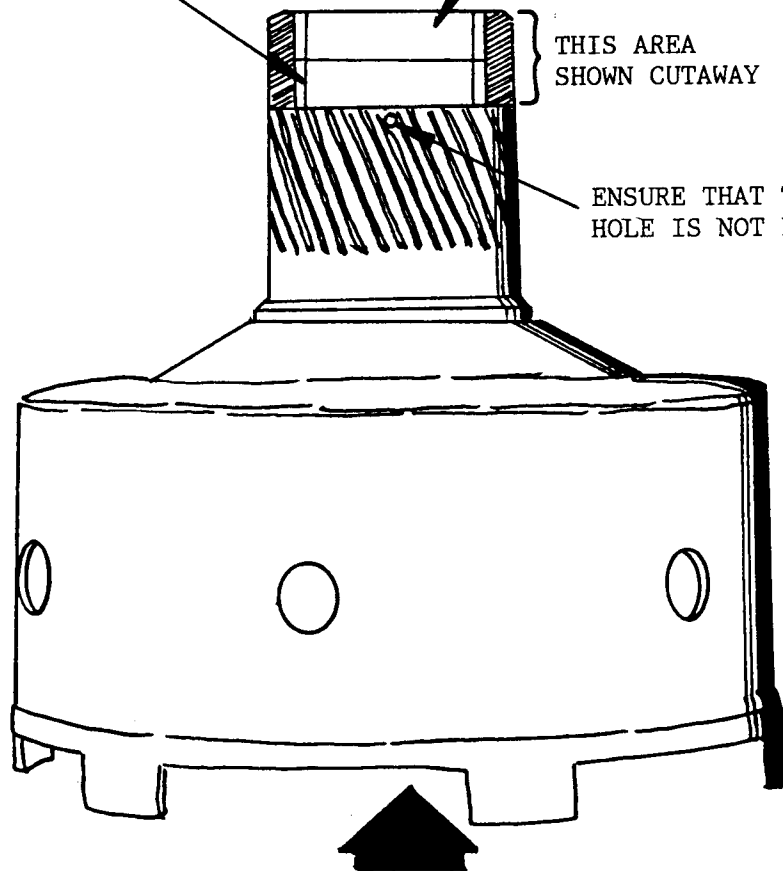

SUPPORT SUN GEAR FROM THIS END WHILE PRESSING BUSHINGS TO PREVENT DAMAGE TO SUN GEAR SHELL.

Figure 31



Technical Service Information

FORD - AXOD

INTERMEDIATE CLUTCH PACK CHANGE

CHANGE: Beginning in model year 1988, a "Wave Plate" was added to the intermediate clutch pack on 3.8L models, and a flat "Spacer Plate" was added on 3.0L models.

REASON: To help cushion the 1-2 shift on 3.8L models.

PARTS AFFECTED:

- (1) **WAVE PLATE/SPACER PLATE** - Either a wave plate or a flat spacer plate was added, depending on engine size. 3.8L models received a wave plate, and 3.0L models received a flat spacer plate.
The wave plate used in the forward and intermediate clutch packs are very similar. To identify them measure the thickness of each. The forward wave plate will measure approximately .075" thick, and the intermediate wave plate will measure approximately .062" thick, as shown in Figure 34. The flat spacer plate for the 3.0L models measures .118" thick, as shown in Figure 36.
Refer to Figure 36 for proper position in the clutch pack, of the wave plate or the spacer plate, as some manuals are wrong.
- (2) **INTERMEDIATE CLUTCH HUB** - Overall height was made shorter by approximately .060" with no identifying marks. The hub **MUST** be measured with a dial caliper or depth gage.
The 1st design hub will measure 1.627"-1.640", and the 2nd design hub will measure 1.568"-1.580" as shown in Figure 32.
- (3) **INTERMEDIATE CLUTCH STEEL PLATES** - Thickness was reduced by .020" to help accommodate the added wave plate on 3.8L models, or the added spacer plate on 3.0L models.
The 1st design steel plates are .090" thick, and the 2nd design steel plates are .070" thick as shown in Figure 33.
- (4) **INTERMEDIATE CLUTCH PRESSURE PLATE** - Thickness was reduced by .065" to help accommodate the added wave plate on 3.8L models, or the added spacer plate on 3.0L models.
The 1st design pressure plate is .190" thick, and the 2nd design pressure plate is .125" thick as shown in Figure 35.

INTERCHANGEABILITY:

YOU CANNOT INTERCHANGE THE INTERMEDIATE CLUTCH COMPONENTS LISTED ABOVE, WITH THOSE OF ANY PREVIOUS DESIGN LEVEL.

For model years 1986, 1987, and 1989 transaxles built BEFORE 04/18/89, the intermediate clutch WILL NOT have a wave plate nor spacer plate, and all use 1st design components.

For all 1988 models and 1989 model transaxles built AFTER 04/17/89, the intermediate clutch MUST have a wave plate or spacer plate, and all use 2nd design components.

Refer to Page 42 to determine which transaxles use 1st design components and which use 2nd design components.

AUTOMATIC TRANSMISSION SERVICE GROUP



Technical Service Information

SERVICE INFORMATION:

INTERMEDIATE CLUTCH WAVE PLATE (3.8L ENGINE)	E8DZ-7E085-A
INTERMEDIATE CLUTCH SPACER PLATE (3.0L ENGINE)	E8DZ-7B437-A
INTERMEDIATE CLUTCH STEEL PLATE (1ST DESIGN .090")	E6DZ-7B442-B
INTERMEDIATE CLUTCH STEEL PLATE (2ND DESIGN .070")	E6DZ-7B442-A
INTERMEDIATE CLUTCH HUB (1ST DESIGN 1.627"-1.640")	E6DZ-7B067-A
INTERMEDIATE CLUTCH HUB (2ND DESIGN 1.568"-1.580")	E8DZ-7B067-A
INTERMEDIATE CLUTCH PRESSURE PLATE (1ST DESIGN .190")	E6DZ-7B066-B
INTERMEDIATE CLUTCH PRESSURE PLATE (2ND DESIGN .125")	E8DZ-7B066-A
INTERMEDIATE CLUTCH FRICTION PLATE (ALL MODELS)	E8DZ-7B164-A

NOTE: CLUTCH PACK CLEARANCE;

NON WAVE PLATE (1ST DESIGN)044"-.111"
WAVE PLATE/SPACER PLATE (2ND DESIGN).049"-.119"	



Technical Service Information

86-87	INTERMEDIATE CLUTCH COMPONENTS, ALL MODELS	
	5 Steel Plates (.090" Thick)	E6DZ-7B442-B
	5 Friction Plates	E8DZ-7B164-A
	1 Clutch Hub, 1st Design (1.627"-1.640" Overall Height)	E6DZ-7B067-A
	1 Pressure Plate, 1st Design (.190" Thick)	E6DZ-7B066-A
1988	INTERMEDIATE CLUTCH COMPONENTS, 3.8L ENGINE ONLY	
	1 Wave Plate (.157" Thick)	E8DZ-7E085-A
	5 Steel Plates (.070" Thick)	E6DZ-7B442-A
	5 Friction Plates	E8DZ-7B164-A
	1 Clutch Hub, 2nd Design (1.568"-1.580" Overall Height)	E8DZ-7B067-A
	1 Pressure Plate, 2nd Design (.125" Thick)	E8DZ-7B066-A
1988	INTERMEDIATE CLUTCH COMPONENTS, 3.0L ENGINE ONLY	
	1 Flat Spacer Plate	E8DZ-7B437-A
	5 Steel Plates (.070" Thick)	E6DZ-7B442-A
	5 Friction Plates	E8DZ-7B164-A
	1 Clutch Hub, 2nd Design (1.568"-1.580" Overall Height)	E8DZ-7B067-A
	1 Pressure Plate, 2nd Design (.125" Thick)	E8DZ-7B066-A
1989	INTERMEDIATE CLUTCH COMPONENTS (BEFORE 04/18/89), ALL MODELS	
	5 Steel Plates (.090" Thick)	E6DZ-7B442-B
	5 Friction Plates	E8DZ-7B164-A
	1 Clutch Hub, 1st Design (1.627"-1.640" Overall Height)	E6DZ-7B067-A
	1 Pressure Plate, 1st Design (.190" Thick)	E6DZ-7B066-A
1989	INTERMEDIATE CLUTCH COMPONENTS (AFTER 04/17/89), 3.8L ENGINE ONLY	
	1 Wave Plate (.157" Thick)	E8DZ-7E085-A
	5 Steel Plates (.070" Thick)	E6DZ-7B442-A
	5 Friction Plates	E8DZ-7B164-A
	1 Clutch Hub, 2nd Design (1.568"-1.580" Overall Height)	E8DZ-7B067-A
	1 Pressure Plate, 2nd Design (.125" Thick)	E8DZ-7B066-A
1989	INTERMEDIATE CLUTCH COMPONENTS (AFTER 04/17/89), 3.0L ENGINE ONLY	
	1 Flat Spacer Plate	E8DZ-7B437-A
	5 Steel Plates (.070" Thick)	E6DZ-7B442-A
	5 Friction Plates	E8DZ-7B164-A
	1 Clutch Hub, 2nd Design (1.568"-1.580" Overall Height)	E8DZ-7B067-A
	1 Pressure Plate, 2nd Design (.125" Thick)	E8DZ-7B066-A
1990	INTERMEDIATE CLUTCH COMPONENTS, 3.8L ENGINE ONLY	
	1 Wave Plate (.157" Thick)	E8DZ-7E085-A
	5 Steel Plates (.070" Thick)	E6DZ-7B442-A
	5 Friction Plates	E8DZ-7B164-A
	1 Clutch Hub, 2nd Design (1.568"-1.580" Overall Height)	E8DZ-7B067-A
	1 Pressure Plate, 2nd Design (.125" Thick)	E8DZ-7B066-A
1990	INTERMEDIATE CLUTCH COMPONENTS, 3.0L ENGINE ONLY	
	1 Flat Spacer Plate	E8DZ-7B437-A
	5 Steel Plates (.070" Thick)	E6DZ-7B442-A
	5 Friction Plates	E8DZ-7B164-A
	1 Clutch Hub, 2nd Design (1.568"-1.580" Overall Height)	E8DZ-7B067-A
	1 Pressure Plate, 2nd Design (.125" Thick)	E8DZ-7B066-A
91-92	INTERMEDIATE CLUTCH COMPONENTS, ALL ENGINES, ALL MODELS	
	1 Wave Plate (.157" Thick)	E8DZ-7E085-A
	5 Steel Plates (.070" Thick)	E6DZ-7B442-A
	5 Friction Plates	E8DZ-7B164-A
	1 Clutch Hub, 2nd Design (1.568"-1.580" Overall Height)	E8DZ-7B067-A
	1 Pressure Plate, 2nd Design (.125" Thick)	E8DZ-7B066-A



Technical Service Information

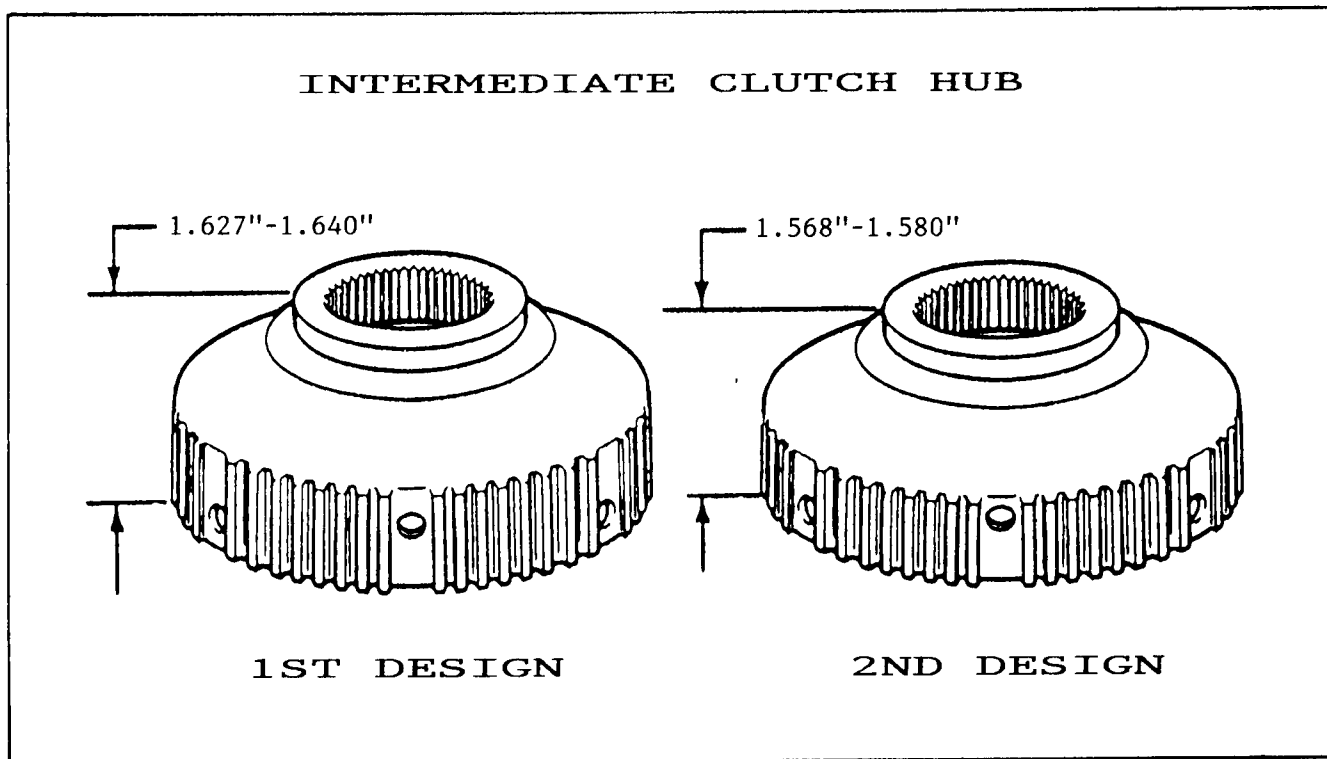

Figure 32

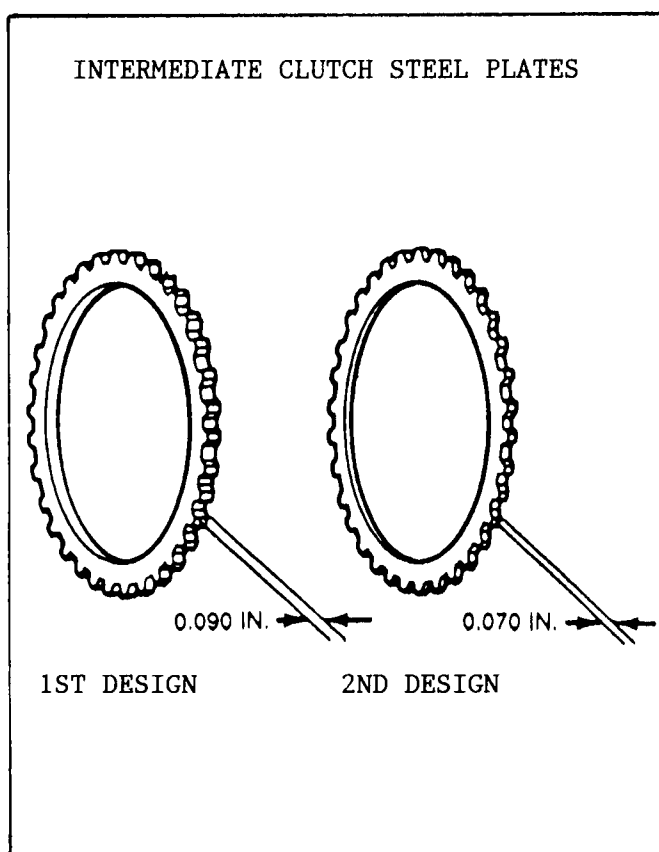

Figure 33

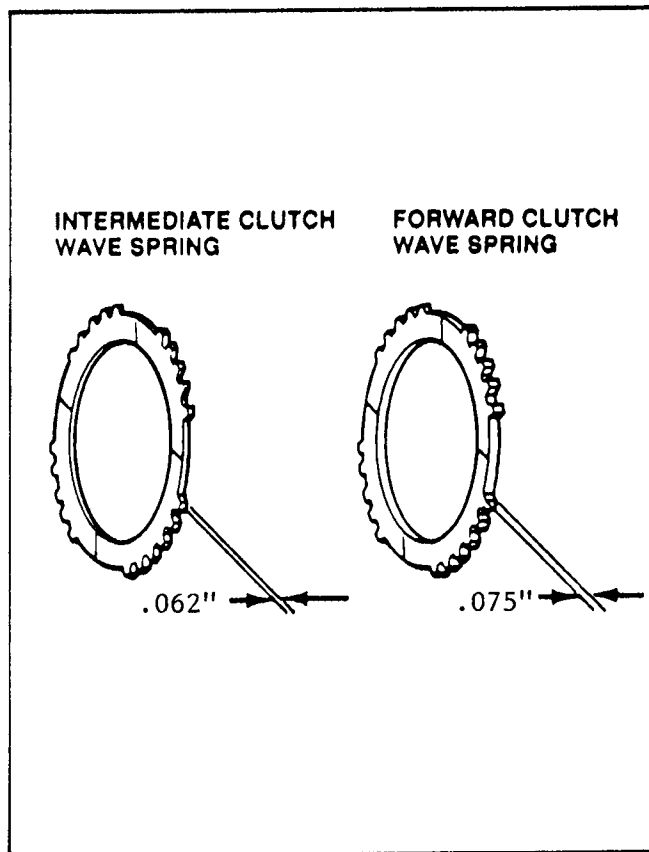

Figure 34



Technical Service Information

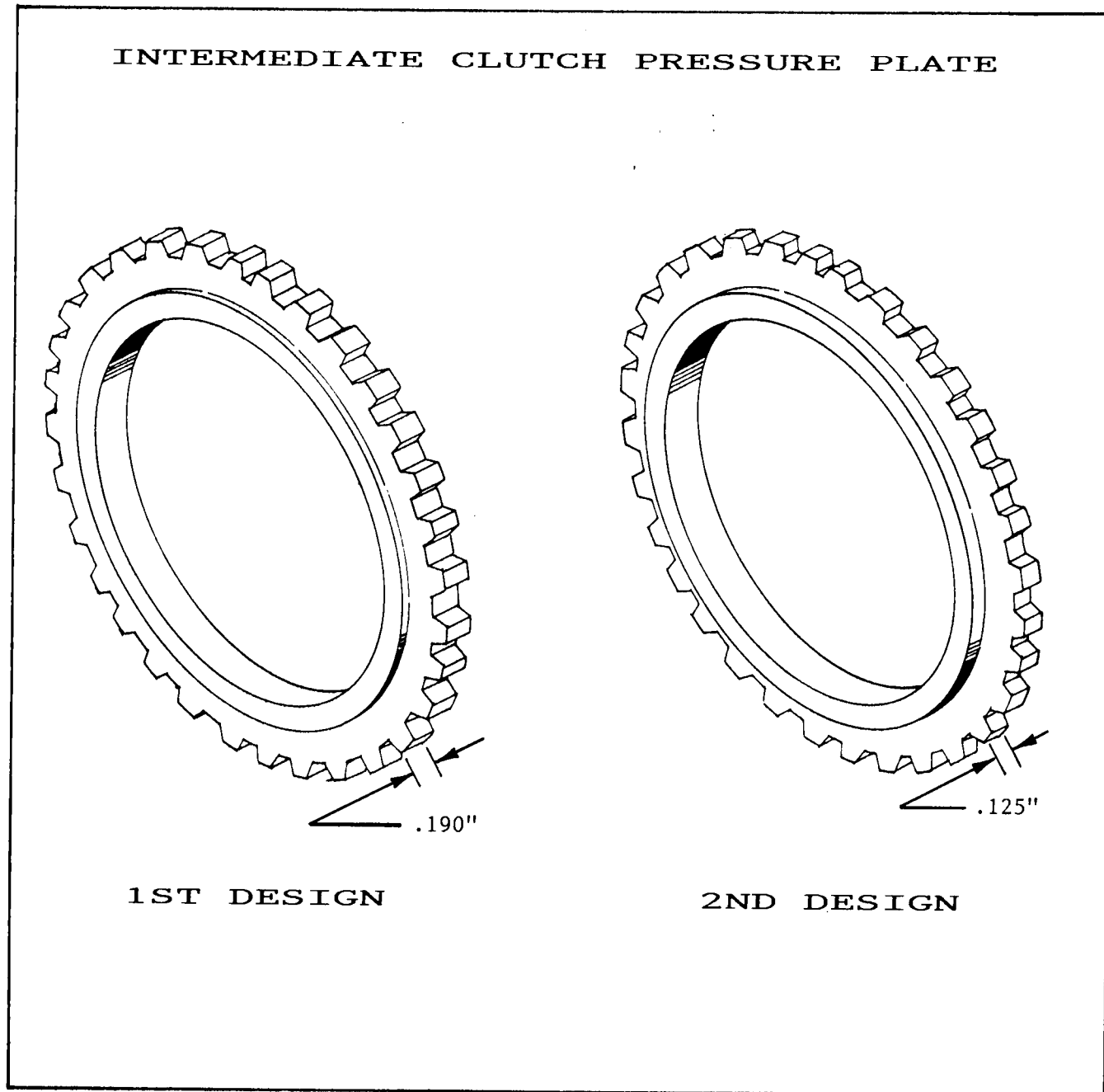

Figure 35



Technical Service Information

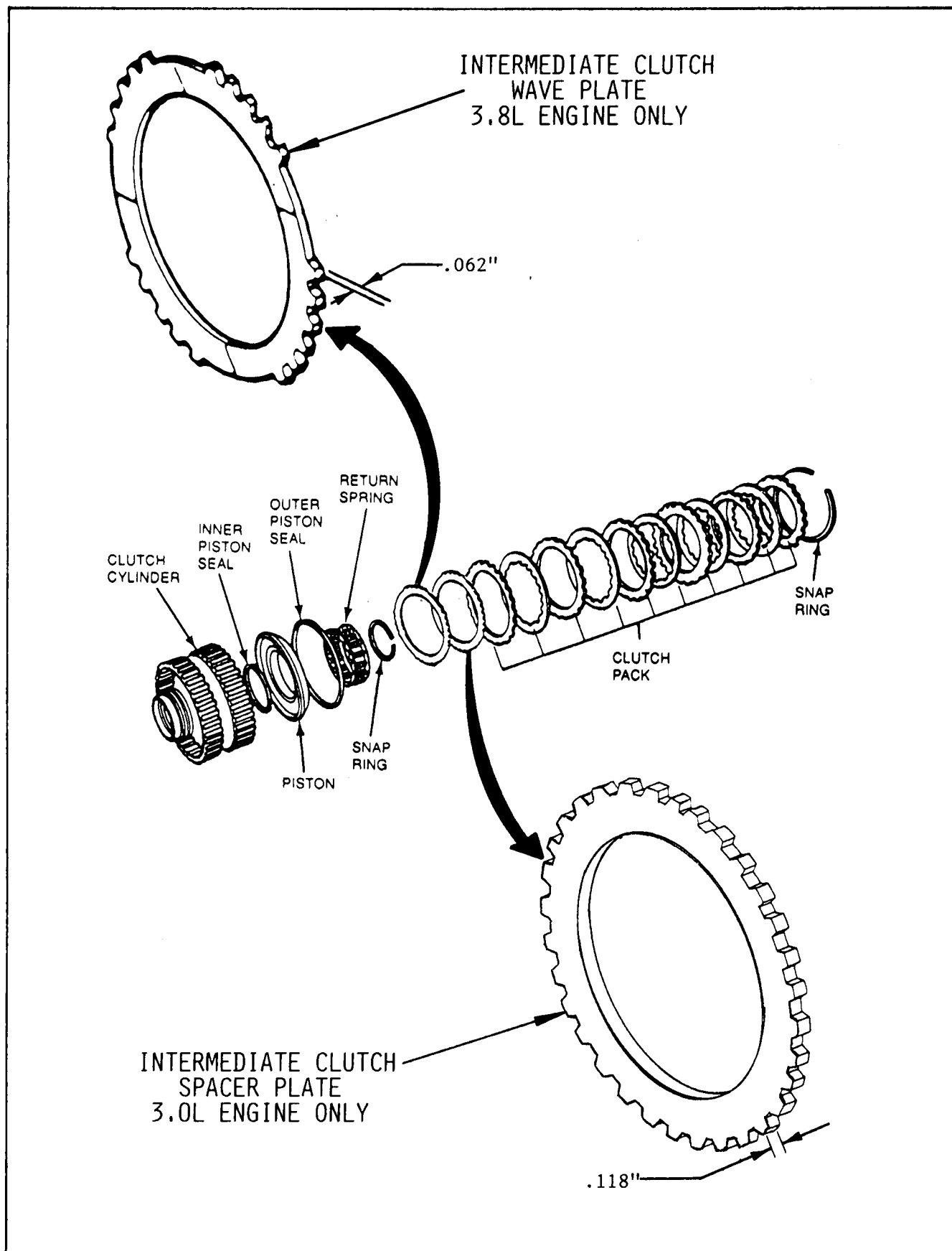

Figure 36
AUTOMATIC TRANSMISSION SERVICE GROUP



Technical Service Information

**FORD AXOD
REVISED SEALING RINGS**

The five sealing rings on the driven sprocket support have been re-designed to help eliminate leakage in this area. The width of the sealing rings has been increased by approximately .015", and the new color identification is orange with green speckles (See Figure 37). The previous design sealing rings were plain orange in color.

The new design sealing rings are available under OEM number E6DZ-7D019-A, and should be used on ALL previous model AXOD transaxles.

DO NOT USE PREVIOUS DESIGN SEALING RINGS.

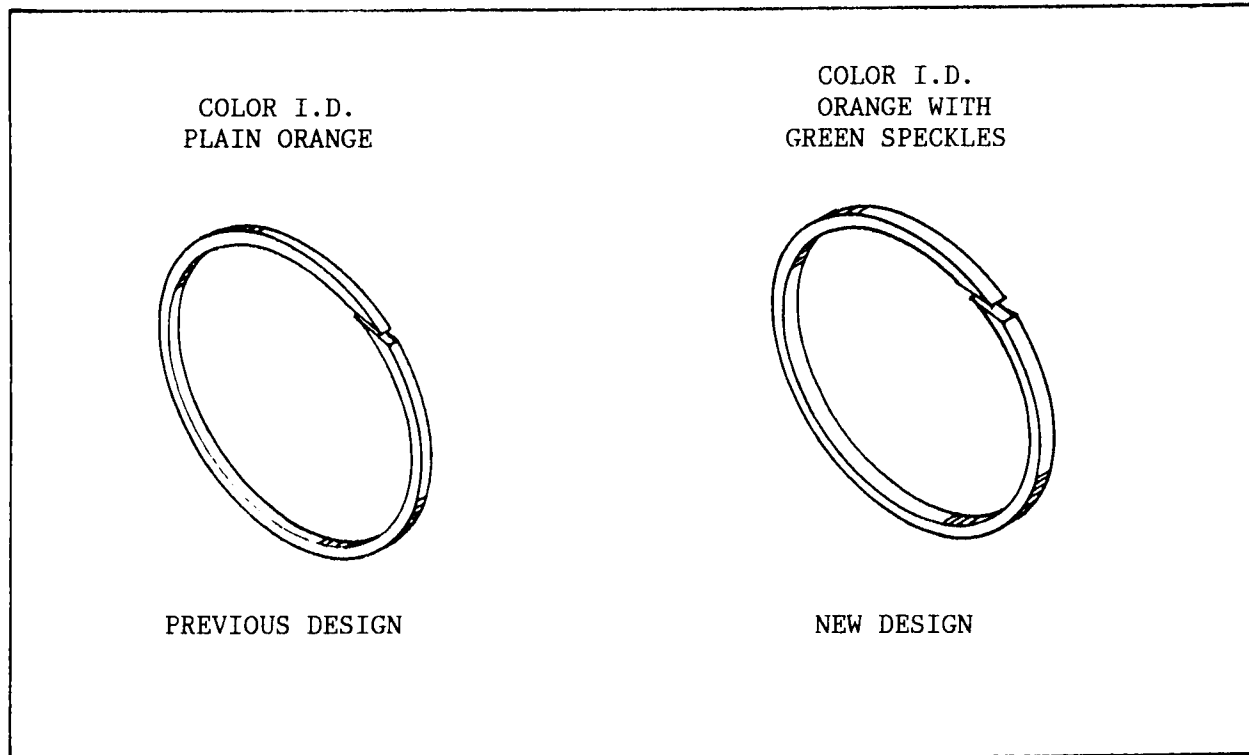

Figure 37



Technical Service Information

1989 FORD AXOD NEW SCREEN IN CASE

CHANGE: A new filter has been added to the 1989 AXOD 1-2 servo apply circuit as shown in Figure 38.

REASON: The filter prevents large metal chips from entering the valve body.

PARTS AFFECTED:

- (1) CHAIN COVER - 1-2 servo passage changed to accommodate the new screen.
- (2) TRANSAXLE CASE - 1-2 servo passage changed to accommodate the new screen.

INTERCHANGEABILITY:

The new screen WILL NOT retro fit to previous models. The 1-2 servo passage on the previous models chain cover will not accommodate the new screen and an interference will occur.

NOTE: A no forward condition could occur if the filter becomes contaminated.

SERVICE INFORMATION:

New Filter E9DZ-7H162-A

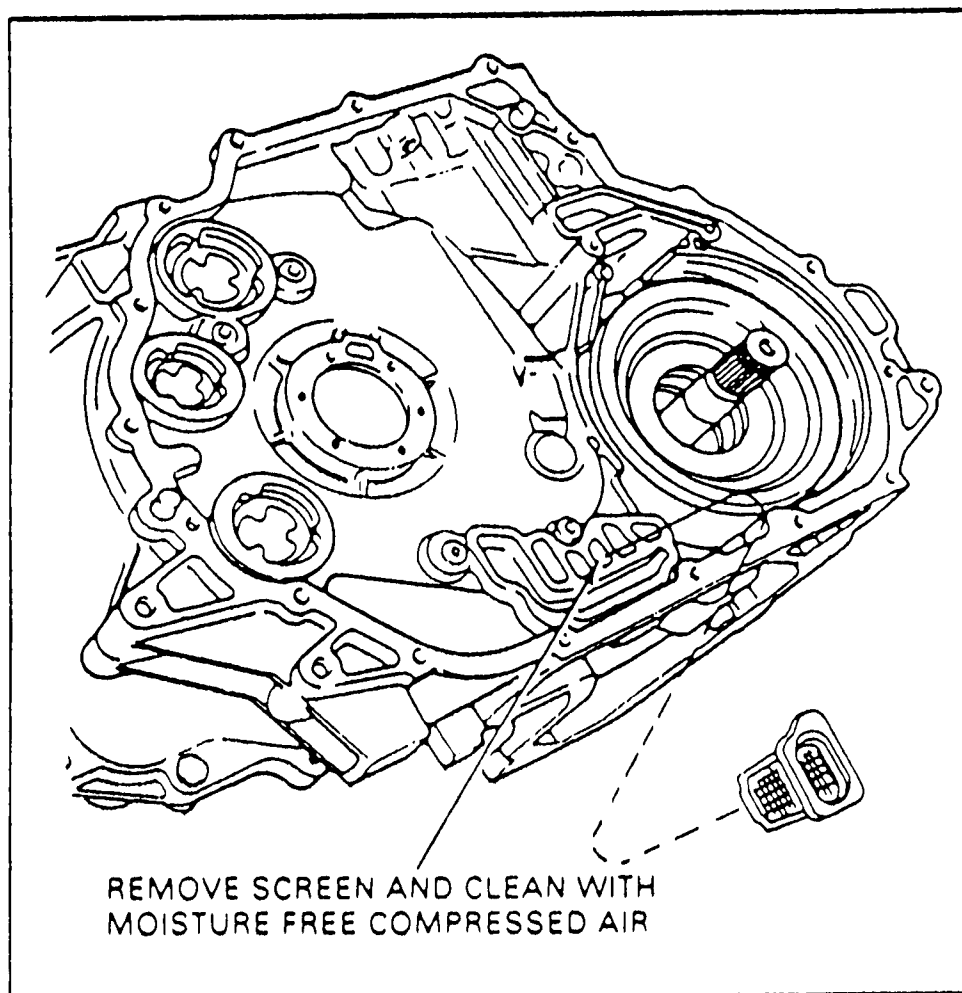

Figure 38

AUTOMATIC TRANSMISSION SERVICE GROUP



Technical Service Information

FORD AXOD/AXODE NEW STEEL FORWARD CLUTCH PISTON

CHANGE: The Forward Clutch Piston material has now been changed to "Steel", instead of the previous design aluminum piston, as shown in Figure 39.

REASON: To eliminate cracks from occurring in the seal groove and greatly improve durability.

PARTS AFFECTED:

- (1) FORWARD CLUTCH PISTON - Now manufactured out of steel, instead of aluminum, and there are no dimensional changes on the piston (See Figure 39).

INTERCHANGEABILITY:

Should be used to back service *ALL* previous models of the AXOD, AXODE and AX4S transaxles. *Always* upgrade the forward clutch piston with the newest design steel piston using the OEM part numbers listed below.

SERVICE INFORMATION:

- Forward Clutch Piston (All Except "SHO" Models) F4DZ-7A262-A
- Forward Clutch Piston (3.2L "SHO" Models Only) F4DZ-7A262-B

NEW DESIGN STEEL FORWARD CLUTCH PISTON

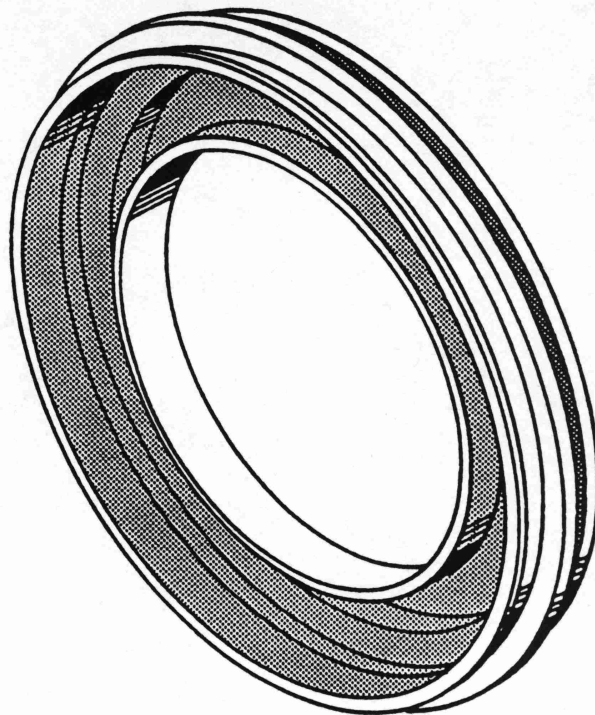

Copyright © 2000 ATSG

Figure 39



Technical Service Information

FORD AXOD HARSH COAST DOWNSHIFT

COMPLAINT: Harsh downshift when coasting to a stop at closed throttle.

CAUSE: Insufficient travel of the 1-2 piston against the cushion spring.

CORRECTION: Remove 1/16" to 3/32" from the boss on the inside of the 1-2 servo piston as shown in Figure 40. We have shaded the area to be machined (See Figure 40).

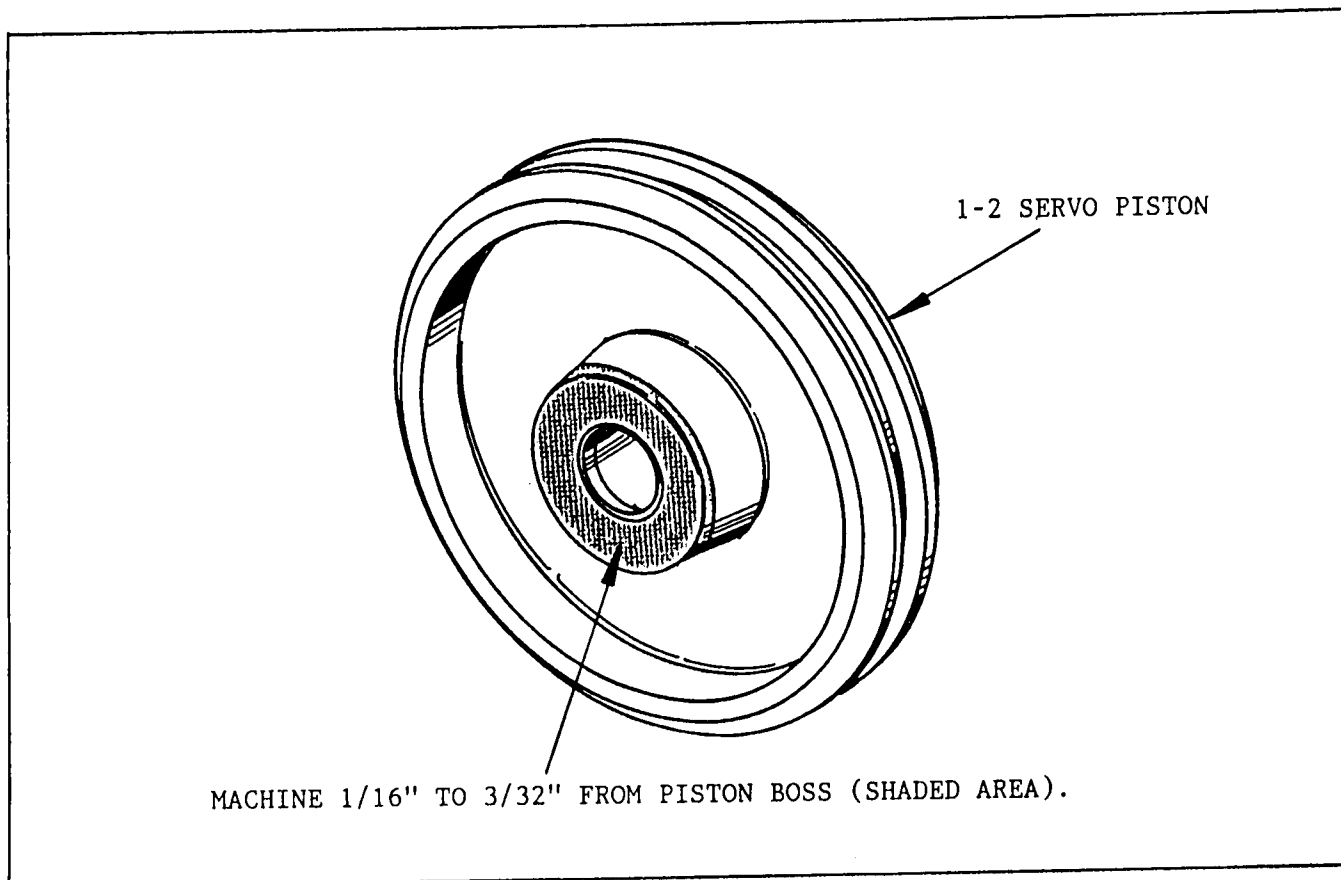

Figure 40



Technical Service Information

FORD AXOD

NO 3-4 SHIFT

- COMPLAINT:** An extended 3-4 shift with possible direct clutch failure or a NO 3-4 shift condition.
- CAUSE:** This condition may be caused by a partially or fully blocked oil flow of the direct clutch piston check ball assembly.
- CORRECTION:** Special care must be taken during the overhaul operation when re-assembling the direct clutch return spring over the direct clutch piston. Make sure that the notch in the spring bottom retainer (See Figure 41) is positioned properly over the check ball capsule so as not to block or restrict oil flow of the check ball assembly. Refer to Figure 41.

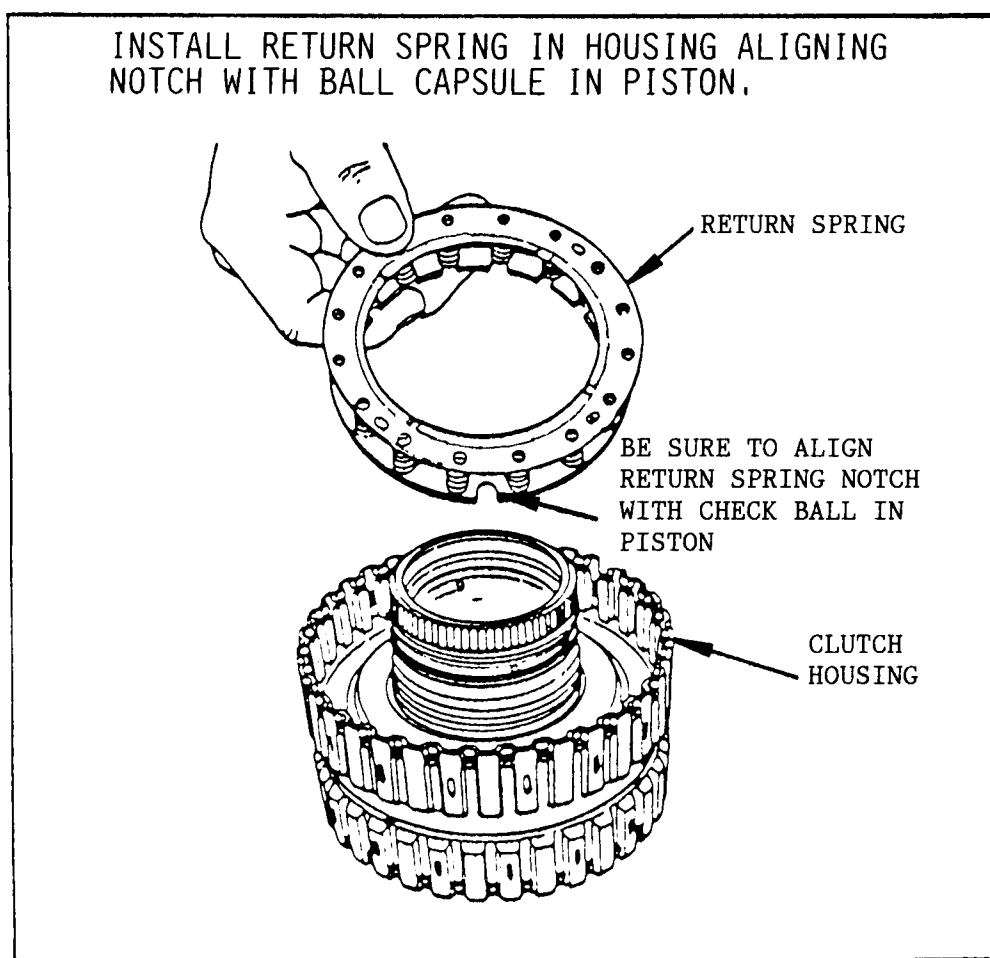

Figure 41



Technical Service Information

FORD AXOD

SPROCKET RATIO IDENTIFICATION

	<u>YEAR</u>	<u>ENGINE SIZE</u>	<u>DRIVE SPRKT</u>	<u>DRIVEN SPRKT</u>
TAURUS & SABLE	ALL	3.0L ENGINE	37T	36T
	ALL	3.8L ENGINE	38T	35T
CONTINENTAL	1988	3.8L ENGINE	38T	35T
	89/90	3.8L ENGINE	37T	36T

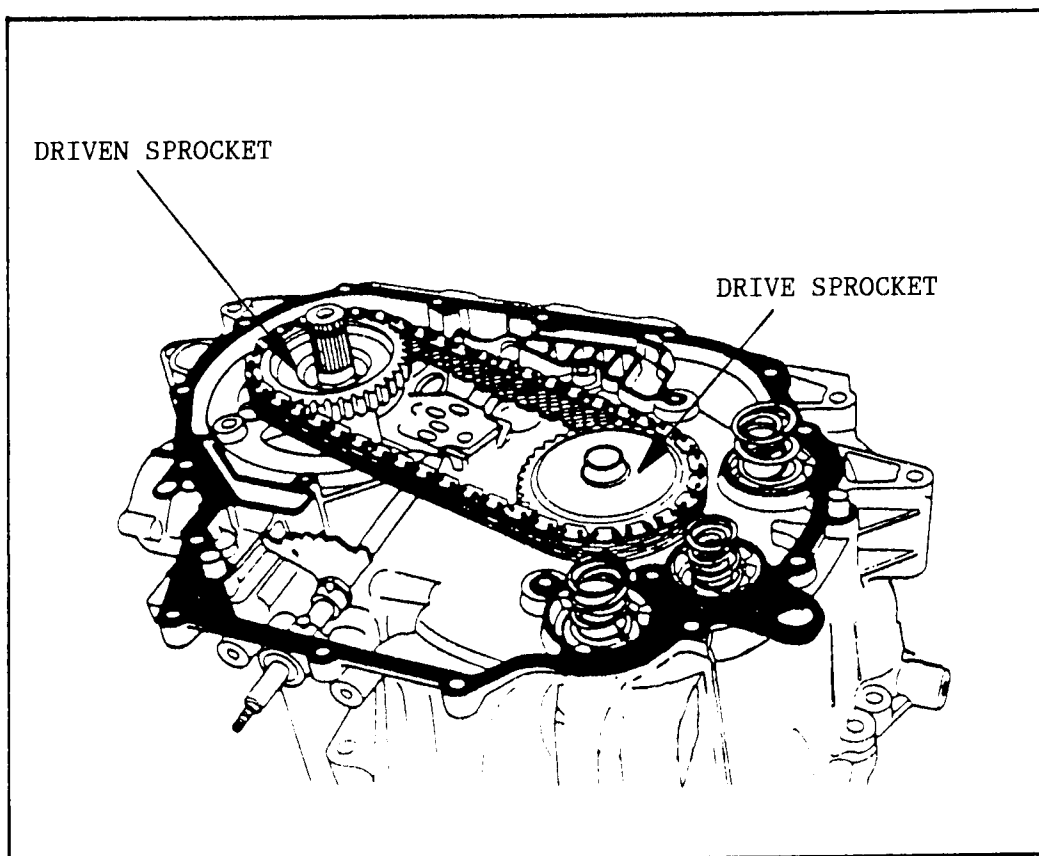

Figure 42



Technical Service Information

FORD AXOD SHUDDER ON 1-2 UPSHIFT DELAYED UPSHIFTS

COMPLAINT: NO. 1. A "Shudder" during a 1-2 upshift at moderate to heavy throttle after cleaning the valve body. The transmission will perform normally at light throttle openings.

NO. 2. Delayed upshifts after cleaning the valve body.

CAUSE: NO. 1. A "Shudder" during a 1-2 upshift will occur if the main pressure regulator "Isolator" spring is not installed after cleaning the valve body (See Figure 43). This is caused by fluctuations in main line pressure at the time of the 1-2 shift.

NO. 2. Delayed upshifts can be caused by the pressure regulator spring retainer being installed backwards (See Figure 43). This will create low main line pressure.

CORRECTION: NO. 1. Insure that all three (3) pressure regulator springs are re-installed in the valve body regulator bore (See Figure 43).

1. Main Pressure Regulator Spring (Largest Diameter).
2. Main Regulator Boost Spring (Medium Diameter).
3. Main Regulator Isolator Spring (Smallest Diameter).

NO. 2. Insure that the main regulator spring retainer is installed in the proper direction (See Figure 43). The retainer is very similar to the one used in the AOD valve body, but is installed in the opposite direction of the AOD (See Figure 43).



Technical Service Information

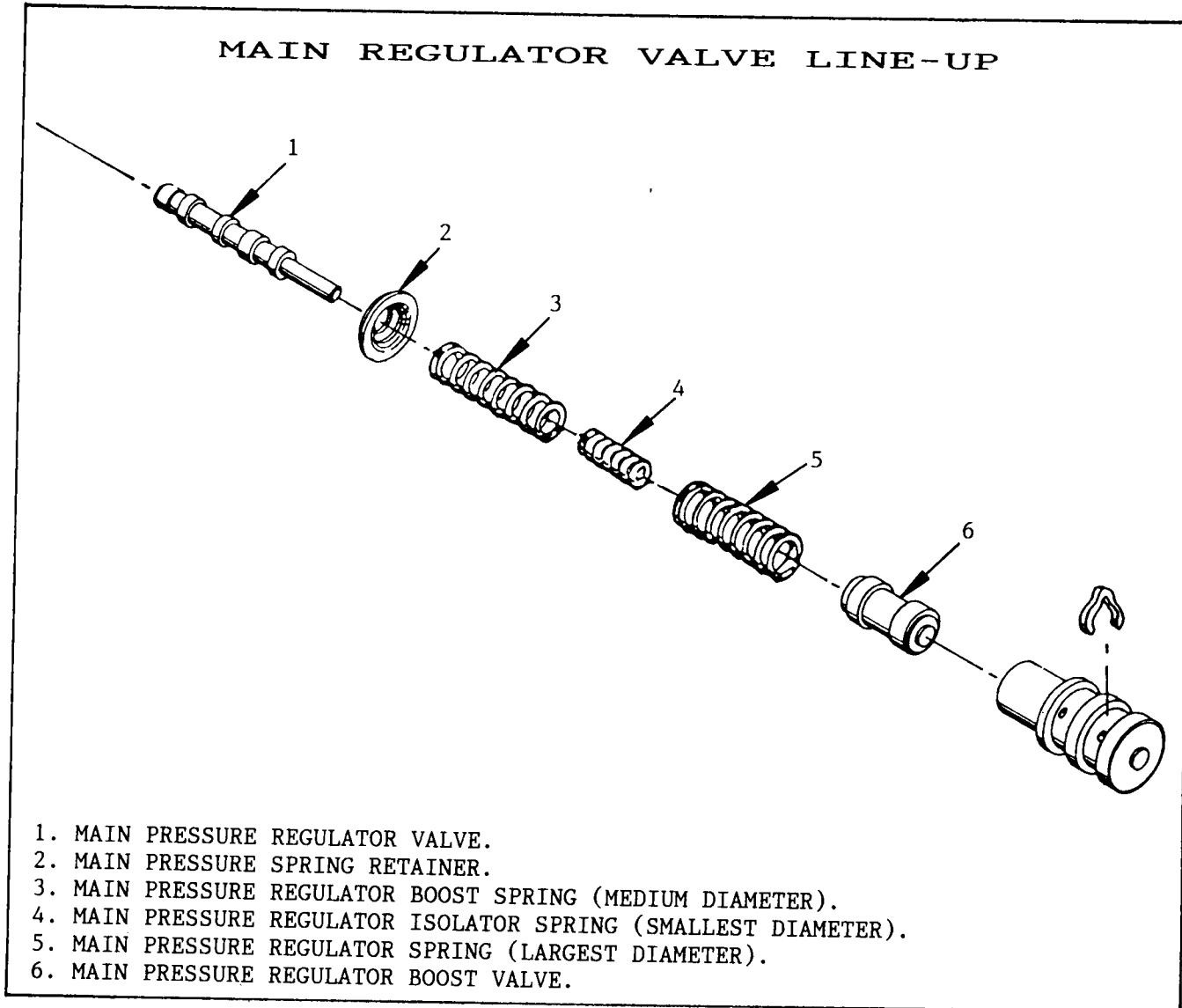

Figure 43



Technical Service Information

FORD AXOD AND AXODE (AX4S)

WEAR ON OIL PUMP SHAFT AND BEARING

Proper alignment of the oil pump and the valve body are mandatory to prevent premature wear of the oil pump drive shaft and the bearing assembly located in the pump housing. When re-assembling the valve body and oil pump, use the guide pins to assure proper alignment.

INSTALLATION PROCEDURE:

1. Position the spacer plate on the pump housing, using a new gasket.
2. Insert valve body guide pin T86P-70100-A (.271" Diameter) and valve body guide pin T86P-70100-B (.262" Diameter), as shown in Figure 44.
3. Install two "Torx" bolts and torque to 7 to 9 ft.lb.
4. Remove both guide pins.
5. Position the spacer plate on the valve body using a new gasket.
6. Insert two valve body guide pins T86P-70100-A (.271" Diameter), as shown in Figure 45.
7. Install two "Torx" bolts and torque to 7 to 9 ft.lb.
8. Position the oil pump on the valve body using a new gasket.
9. Insert pump body guide pin T86P-70370-A and valve body guide pin T86P-70100-C which is .245" in Diameter.
10. Install two valve body to oil pump retaining bolts and torque to 7 to 9 ft.lb.

SERVICE INFORMATION:

Oil Pump Drive Shaft	E6DZ-7B328-A
Pump Bearing With Integral Seal	XF2Z-7G184-AA
Pump Body Guide Pin	T86P-70370-A
Valve Body Guide Pin (.271" Dia. - 2 Required)	T86P-70100-A
Valve Body Guide Pin (.262" Dia.)	T86P-70100-B
Valve Body Guide Pin (.254" Dia.)	T86P-70100-C



Technical Service Information

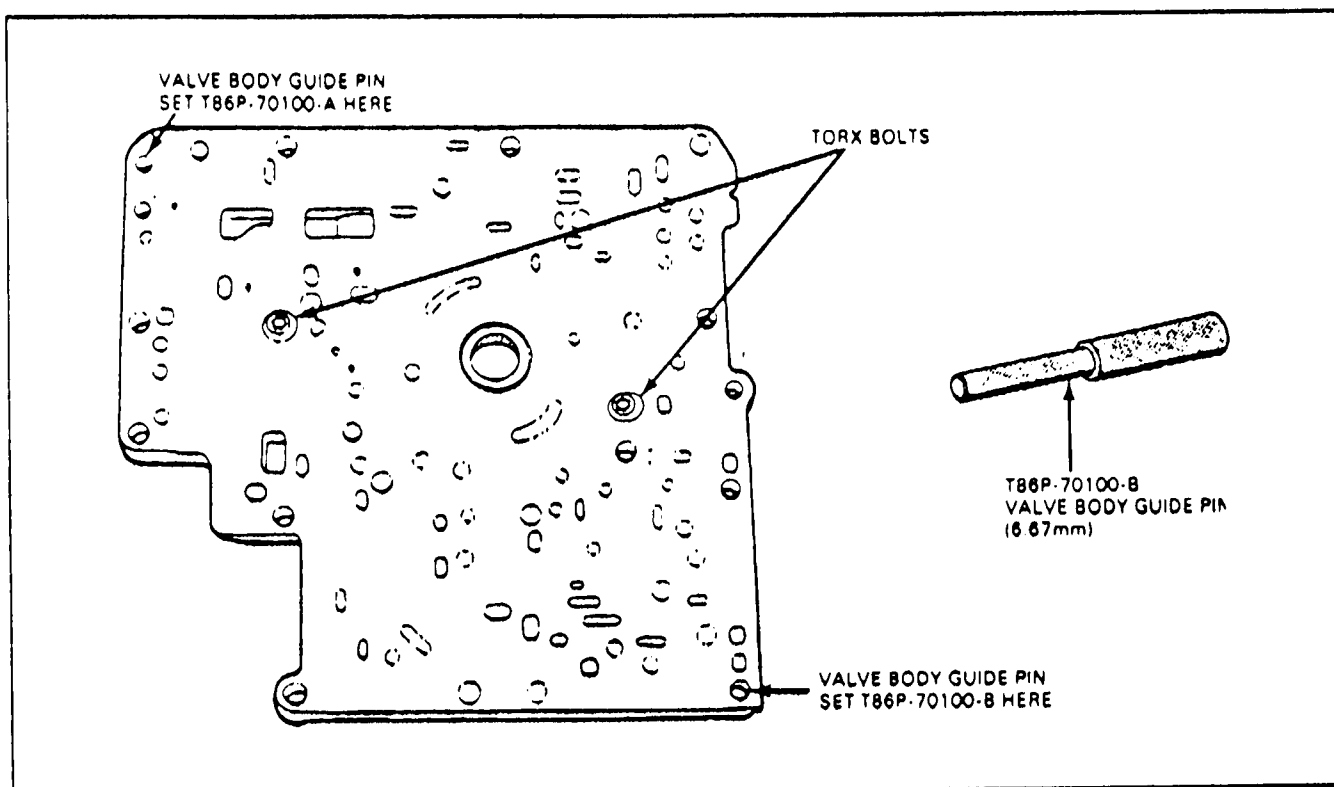

Figure 44

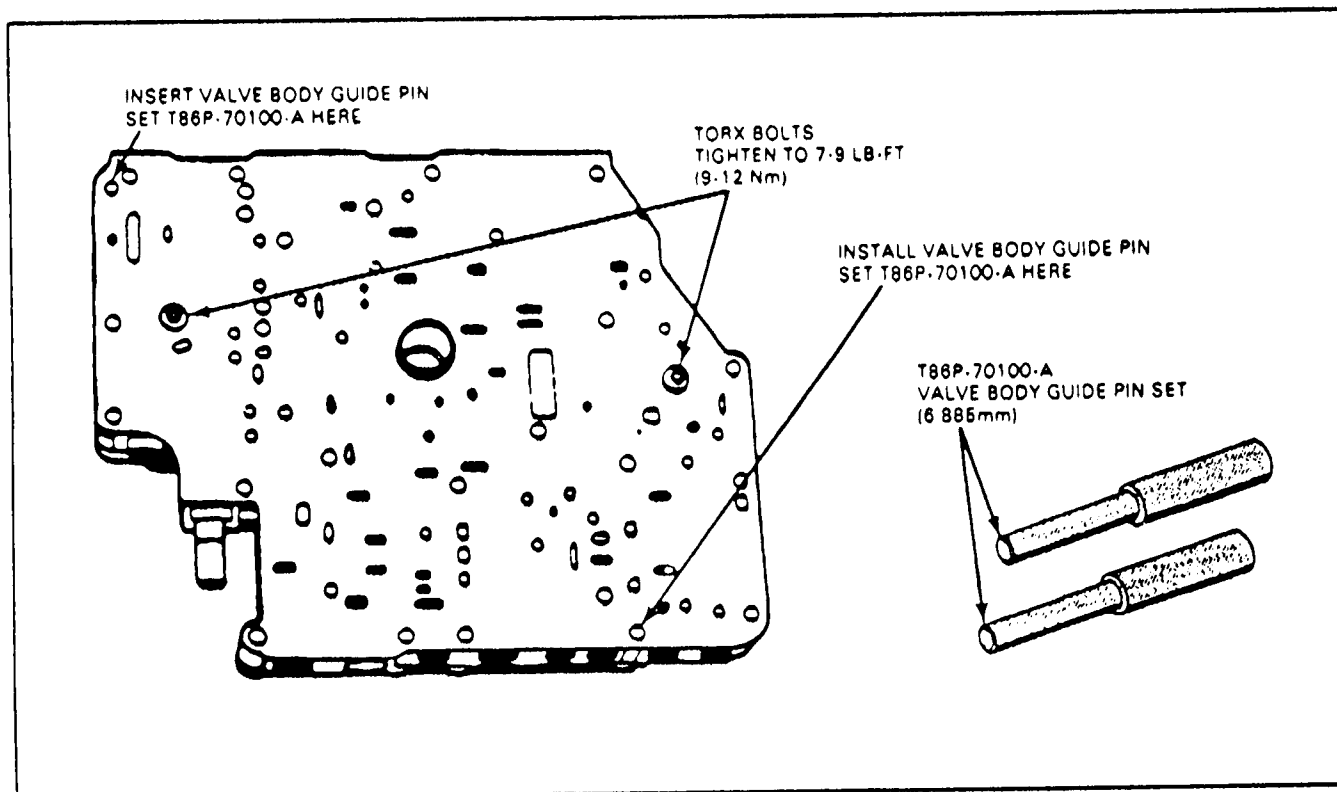

Figure 45



Technical Service Information

FORD AXOD AND AXODE (AX4S) EXPLODED VANE RINGS AND PUMP ROTORS PUMP BEARING CHANGES

CHANGE: Beginning at the start of production for 2001 on all AX4S transaxles, Ford Motor Company introduced a new design pump bearing that includes an integrated seal, as shown in Figure 47. When this new design bearing and seal assembly went into production, it was installed with the *seal on the valve body side of the pump instead of the rotor side.*

REASON: Greatly reduced pump bearing, pump rotor and vane ring failure, for much improved durability and reliability.

INSTALLATION PROCEDURE:

AXOD/AXODE (AX4S) - When using the 1st Design bearing with the "Nickel" Seal, install the seal on the valve body side, with the part number facing up, as shown in Figure 48. When using the 2nd Design bearing with the integrated seal, *which is recommended*, install the bearing assembly with the integrated seal facing the valve body side. The 2nd Design Bearing and Seal assembly *will retro-fit back on all* AXOD, AXODE and the AX4N up through 1999.

SERVICE INFORMATION:

Pump Bearing With Integral Seal XF2Z-7G184-AA

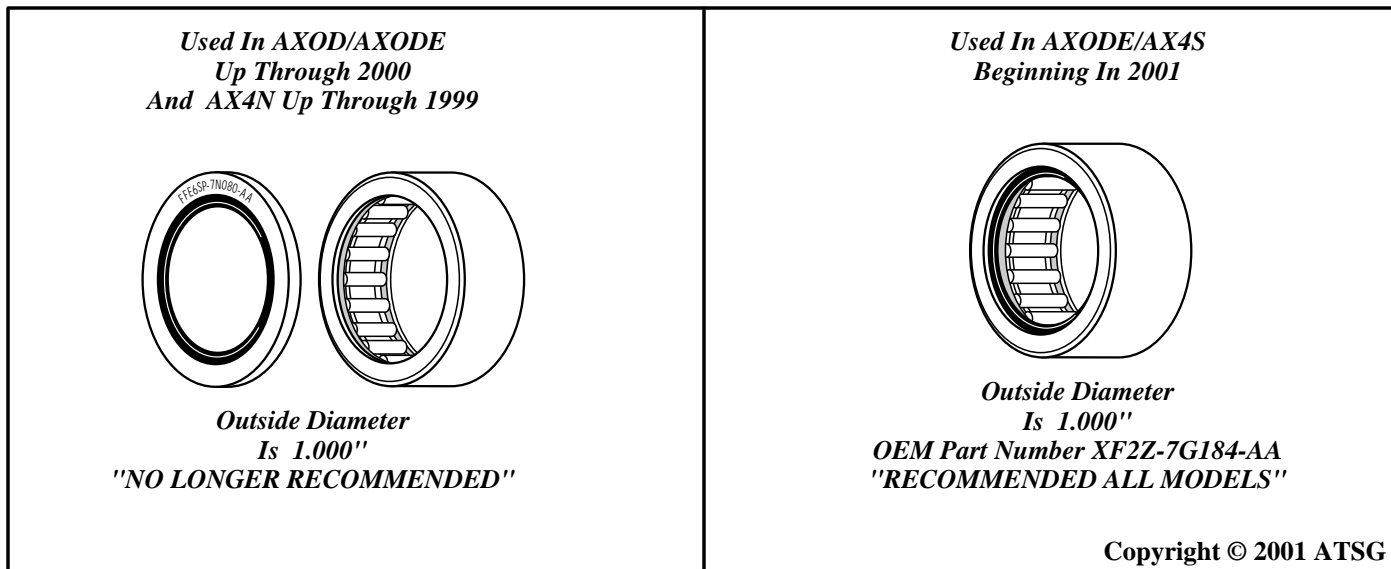

Figure 47

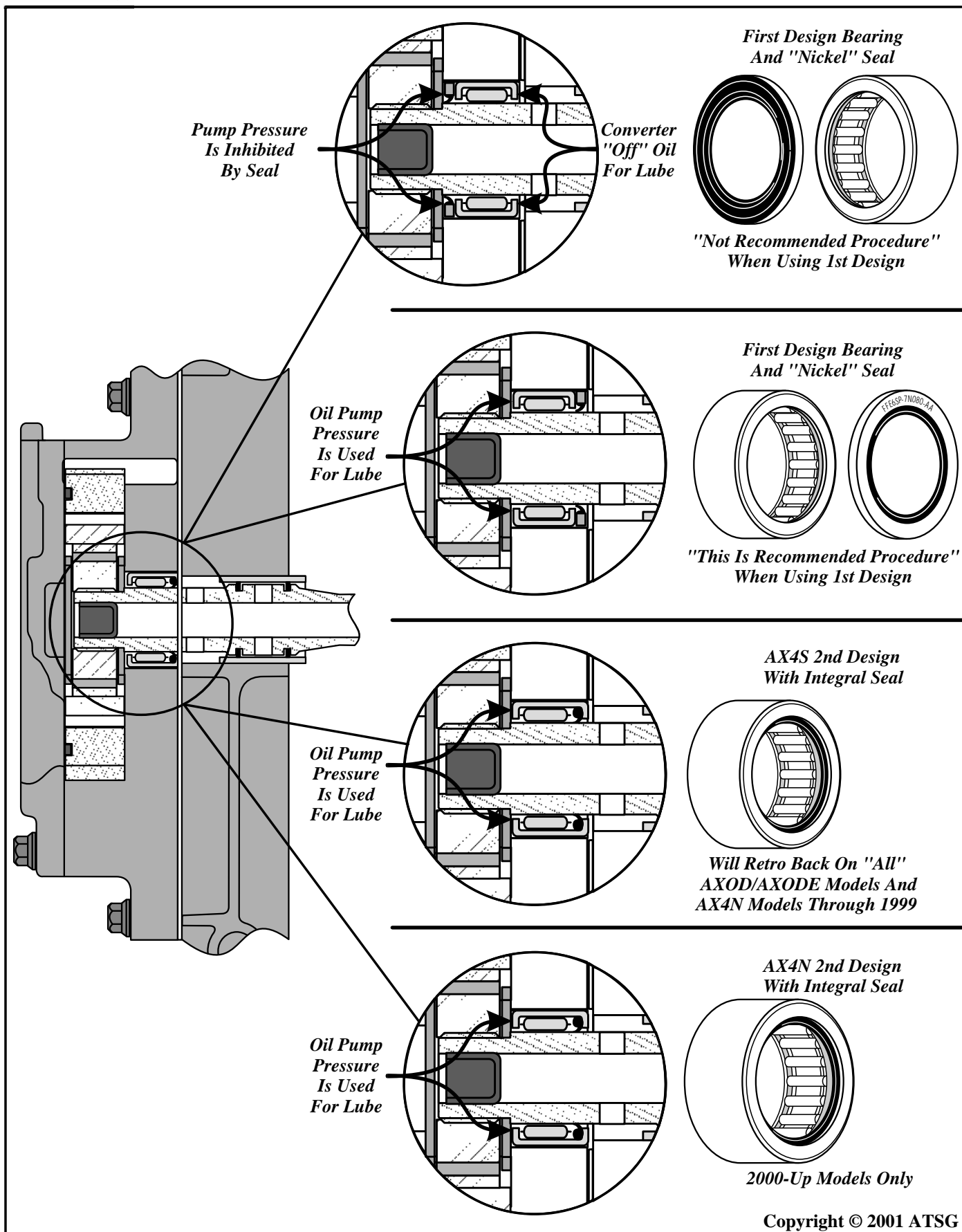

Figure 48



Technical Service Information

FORD AXOD, AXODE, AX4S ACCUMULATOR SPRING IDENTIFICATION

COMPLAINT: Shift quality complaints of various types, mostly harsh shift complaints, after the transmission has been overhauled.

CAUSE: The accumulator springs may have been installed in incorrect positions, or the accumulator piston shafts are scored or worn and are interfering with proper accumulator piston movement. It is also important to insure that multiple accumulator spring applications must have the springs wound in opposite directions of each other to avoid coil bind, as shown in Figure 49.

CORRECTION: Ensure that the accumulator springs have been installed in their proper locations. Refer to Figures 49 and 50 for accumulator spring identification and position. We have also provided you with the accumulator spring specifications in Figure 51.

SERVICE INFORMATION:

Part numbers for each accumulator spring is provided in the chart in Figure 50.



Technical Service Information

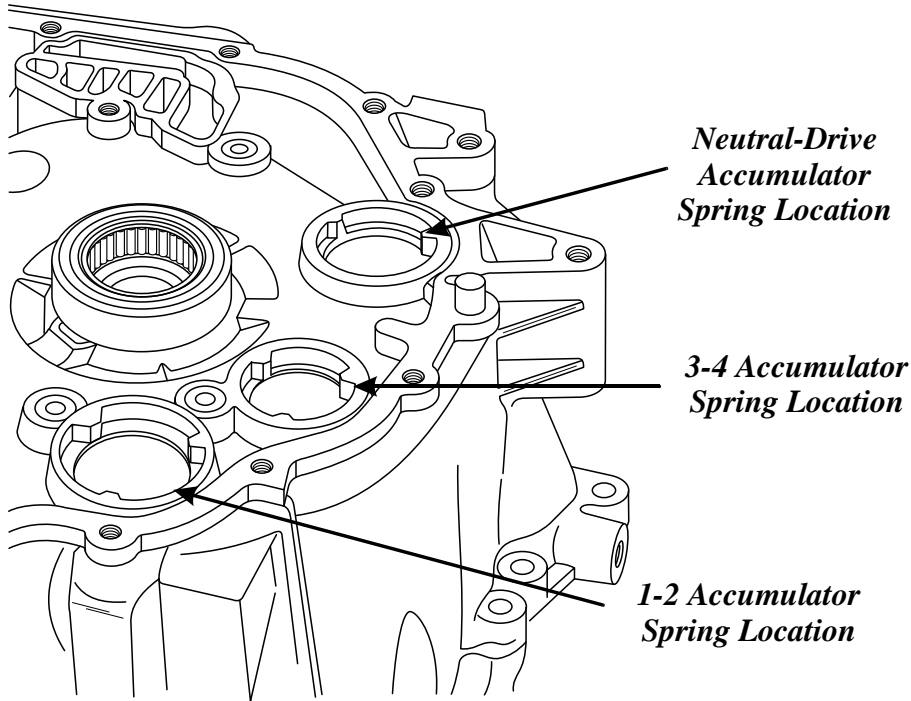

ACCUMULATOR SPRINGS

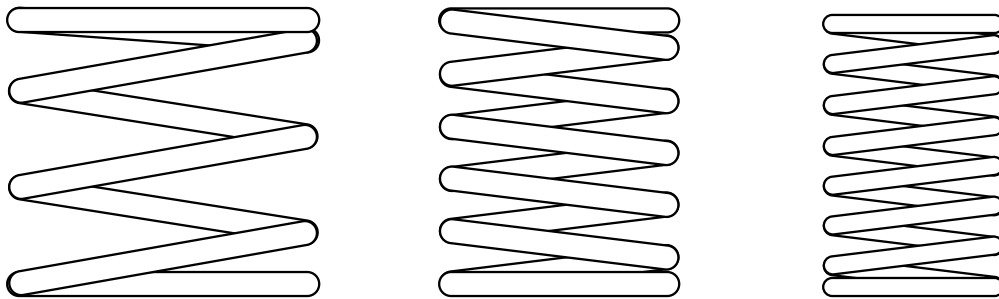

SPRINGS ARE WOUND OPPOSITE OF EACH OTHER TO AVOID COIL BIND

Copyright © 2002 ATSG

Figure 49

AUTOMATIC TRANSMISSION SERVICE GROUP



Technical Service Information

AXOD, AXODE, AX4S, NEUTRAL-DRIVE ACCUMULATOR SPRINGS						
APPLICATION	INNER SPRING		OUTER SPRING			
	Color	Part Number	Color	Part Number		
1986-1997 "All Models"	Blue	E6DZ-7G301-A	Orange	E6DZ-7G300-A		
1995-1997 Windstar	Blue	E6DZ-7G301-A	Orange	E6DZ-7G300-A		
1998-2001 "All Models"	None Used		Green	F8DZ-7G300-BA		
AXOD, AXODE, AX4S, 1-2 ACCUMULATOR SPRINGS						
APPLICATION	INNER SPRING		MIDDLE SPRING		OUTER SPRING	
	Color	Part Number	Color	Part Number	Color	Part Number
86-90 "3.0 Liter"	Yellow	E6DZ-7G326-A	None Used		Yellow	E6DZ-7G267-A
88-90 "3.8 Liter"	Brown	E8DZ-7G326-A	Brown	E8DZ-7G358-A	Lt. Brwn	E8DZ-7G267-A
91-94 "All Models"	* Purple	*E8DZ-7G326-A	* Pink	*E8DZ-7G358-A	Lt. Brwn	E8DZ-7G267-A
95-97 "All Models"	Dk.Brwn	F58Z-7G326-A	Pink	E8DZ-7G358-A	Dk.Brwn	F58Z-7G267-A
1995 Windstar	Dk.Brwn	F58Z-7G326-A	Pink	E8DZ-7G358-A	Dk.Brwn	F58Z-7G267-A
98-01 "All Models"	* Purple	*E8DZ-7G326-A	None Used		Dk.Brwn	F58Z-7G267-A
1996-01 Windstar	Dk.Brwn	F58Z-7G326-A	None Used		Dk.Brwn	F58Z-7G267-A
* Color changed, part number remained the same.						
AXOD, AXODE, AX4S, 3-4 ACCUMULATOR SPRINGS						
APPLICATION	INNER SPRING		OUTER SPRING			
	Color	Part Number	Color	Part Number		
1986-1990 3.0 Liter	Green	E6DZ-7F288-A	Dk. Green	E6DZ-7G266-A		
1988 3.8L Lincoln	Green	E6DZ-7F288-A	Dk. Green	E6DZ-7G266-A		
1988 3.8L Taurus/Sable	Green	E6DZ-7F288-A	Plain	E8DZ-7G266-A		
1991-1997 3.0 Liter	Green	E6DZ-7F288-A	Dk. Green	E6DZ-7G266-A		
1989-1997 3.8 Liter	Green	E6DZ-7F288-A	White	E9DZ-7G266-A		
1998-2001 "All Models"	Green	E6DZ-7F288-A	Yellow	F8DZ-7G266-AA		
Copyright © 2002 ATSG						

Figure 50

AUTOMATIC TRANSMISSION SERVICE GROUP



Technical Service Information

AXOD, AXODE, AX4S, NEUTRAL-DRIVE ACCUMULATOR SPRING "SPECIFICATIONS"			
COLOR	OUTSIDE DIAMETER	FREE LENGTH	WIRE DIAMETER
<i>Blue (Inner)</i>	<i>1.014" (25.75mm)</i>	<i>1.685" (42.82mm)</i>	<i>.097" (2.48mm)</i>
<i>Orange (Outer)</i>	<i>1.480" (37.61mm)</i>	<i>1.813" (46.05mm)</i>	<i>.135" (3.44mm)</i>
<i>Green (Outer)</i>	<i>1.513" (38.43mm)</i>	<i>1.880" (47.46mm)</i>	<i>"Ovate" Wire (O)</i>
AXOD, AXODE, AX4S, 1-2 ACCUMULATOR SPRING "SPECIFICATIONS"			
COLOR	OUTSIDE DIAMETER	FREE LENGTH	WIRE DIAMETER
<i>Yellow (Inner)</i>	<i>1.180" (29.99mm)</i>	<i>1.542" (39.19mm)</i>	<i>.091" (2.30mm)</i>
<i>Brown (Inner)</i>	<i>.902" (22.91mm)</i>	<i>1.507" (38.28mm)</i>	<i>.084" (2.15mm)</i>
<i>Purple (Inner)</i>	<i>.902" (22.91mm)</i>	<i>1.507" (38.28mm)</i>	<i>.084" (2.15mm)</i>
<i>Dk. Brown (Inner)</i>	<i>1.202" (30.55mm)</i>	<i>1.456" (36.99mm)</i>	<i>.106" (2.71mm)</i>
<i>Brown (Middle)</i>	<i>1.216" (30.89mm)</i>	<i>1.443" (36.67mm)</i>	<i>.106" (2.71mm)</i>
<i>Pink (Middle)</i>	<i>1.205" (30.61mm)</i>	<i>1.443" (36.67mm)</i>	<i>.107" (2.73mm)</i>
<i>Yellow (Outer)</i>	<i>1.559" (39.60mm)</i>	<i>1.450" (36.83mm)</i>	<i>.126" (3.22mm)</i>
<i>Lt. Brown (Outer)</i>	<i>1.587" (40.31mm)</i>	<i>1.408" (35.77mm)</i>	<i>.126" (3.22mm)</i>
<i>Dk. Brown (Outer)</i>	<i>1.595" (40.52mm)</i>	<i>1.490" (37.85mm)</i>	<i>.126" (3.22mm)</i>
AXOD, AXODE, AX4S, 3-4 ACCUMULATOR SPRING "SPECIFICATIONS"			
COLOR	OUTSIDE DIAMETER	FREE LENGTH	WIRE DIAMETER
<i>Green (Inner)</i>	<i>.898" (22.81mm)</i>	<i>1.439" (36.55mm)</i>	<i>.081" (2.06mm)</i>
<i>Dk. Green (Outer)</i>	<i>1.189" (30.21mm)</i>	<i>1.484" (37.69mm)</i>	<i>.092" (2.34mm)</i>
<i>Plain (Outer)</i>	<i>1.175" (29.85mm)</i>	<i>1.690" (42.93mm)</i>	<i>.098" (2.49mm)</i>
<i>White (Outer)</i>	<i>1.181" (30.00mm)</i>	<i>1.785" (45.34mm)</i>	<i>.099" (2.52mm)</i>
<i>Yellow (Outer)</i>	<i>1.183" (30.05mm)</i>	<i>1.735" (44.07mm)</i>	<i>.098" (2.49mm)</i>

Copyright © 2002 ATSG

Figure 51

AUTOMATIC TRANSMISSION SERVICE GROUP



Technical Service Information

FORD AXOD, AXODE (AX4S) LOW SPRAG

***THE LOW SPRAG OUTER RACE MUST FREEWHEEL COUNTER CLOCKWISE
AND LOCK CLOCKWISE WHEN HOLDING THE OVERDRIVE DRUM***

**FREEWHEEL
LOW SPRAG
OUTER RACE**

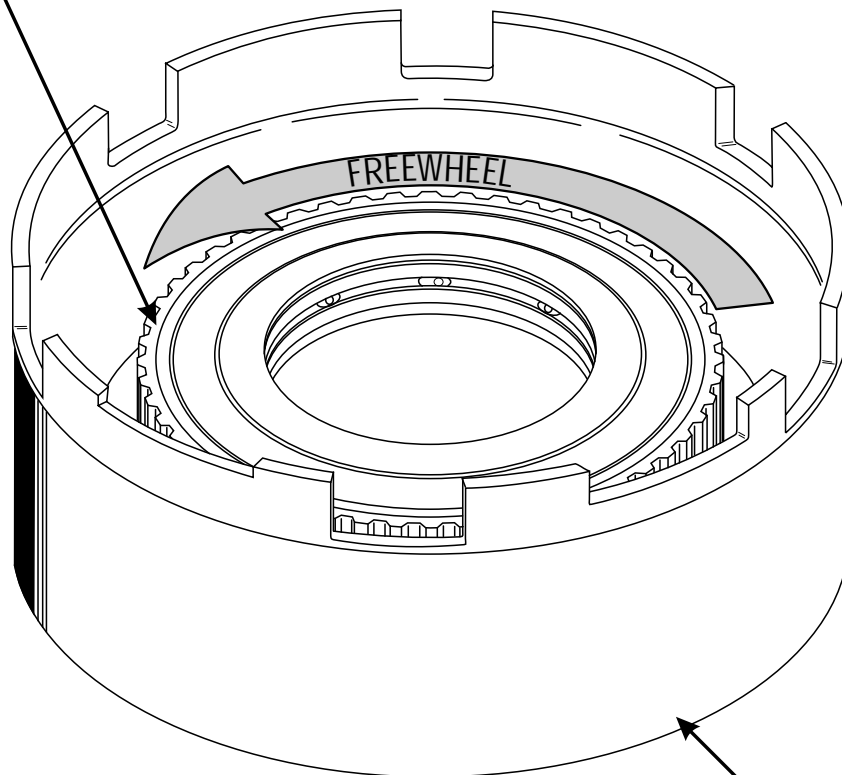

**HOLD
OVERDRIVE DRUM**

Copyright © 2002 ATSG

Figure 52



Technical Service Information

FORD AXOD, AXODE (AX4S) 3RD ROLLER CLUTCH

***THE 3RD ROLLER CLUTCH OUTER RACE MUST FREEWHEEL
CLOCKWISE AND LOCK COUNTER CLOCKWISE WHEN THE
3RD ROLLER CLUTCH INNER RACE IS HELD***

**FREEWHEEL
OUTER RACE**

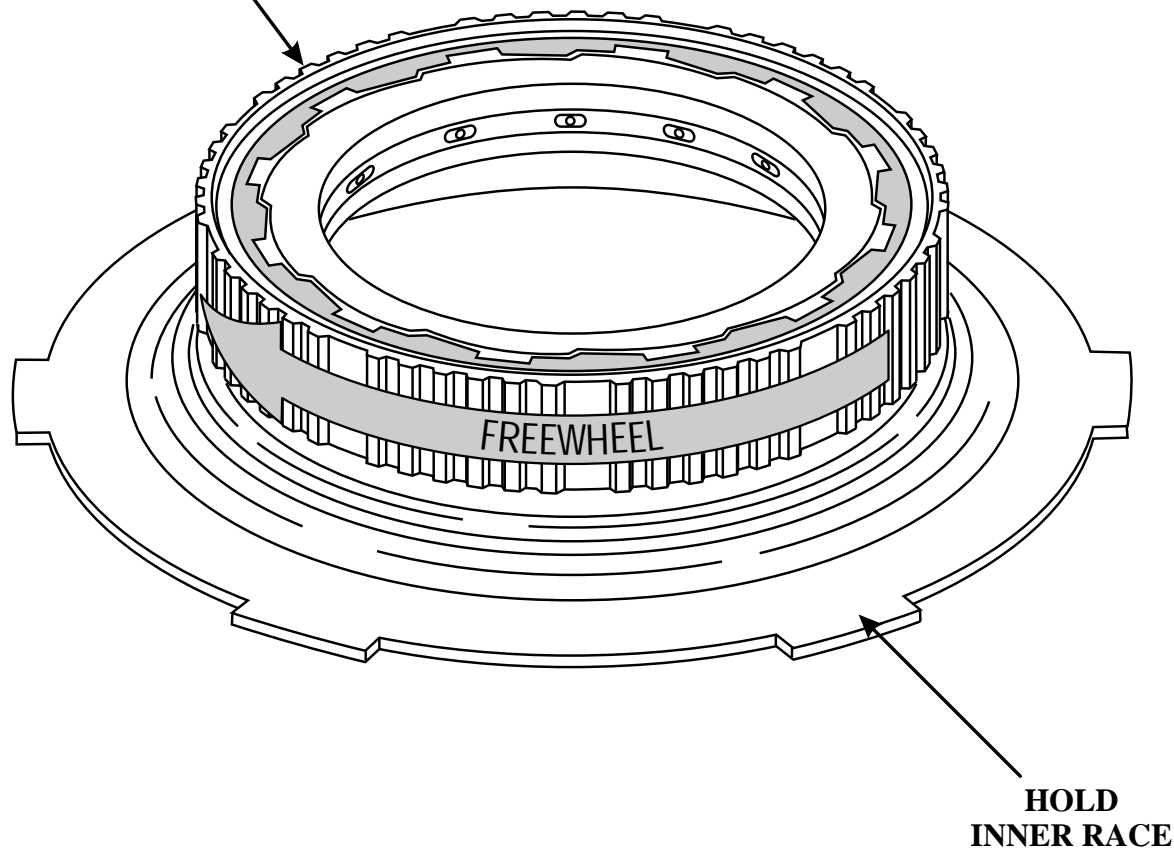

Copyright © 2002 ATSG

Figure 53



Technical Service Information

FORD AXOD/AXODE FORWARD CLUTCH WAVE PLATE CHANGE

CHANGE: The Forward Clutch Wave Plate has been changed three times since the transaxle was introduced in model year 1986.

REASON: To help improve garage shift engagements and to help improve the 4-2 and 3-2 forced downshifts.

PARTS AFFECTED:

(1) FORWARD CLUTCH WAVE PLATE:

1ST DESIGN - Has 4 external teeth, an inside diameter of 4.715", material thickness of .062", and was used from 1986-1988. Refer to Figure 54.

2ND DESIGN - Has 21 external teeth, inside diameter of 4.730", material thickness of .075", identified with letter "X" stamped on 1 tooth, and was used from 1989-1991. (See Figure 55).

3RD DESIGN - Has 21 external teeth, inside diameter of 4.930", material thickness of .083", identified with letter "A" stamped on 1 tooth, used in 1992 and later models. (See Figure 56).

INTERCHANGEABILITY:

The 2nd design forward clutch wave plate will retro-fit back to all previous models and is the recommended wave plate for the AXOD transaxle.

The 3rd design forward clutch wave plate was associated with a change in the entire forward clutch pack and should be used *Only* with the later design forward clutch pack, which are a larger inside diameter.

SERVICE INFORMATION:

Forward Clutch Wave Plate (1st Design)	E6DZ-7E085-B
Forward Clutch Wave Plate (1st Design)	F0DZ-7E085-A
Forward Clutch Wave Plate (1st Design)	F2DZ-7E085-A



Technical Service Information

**FORD AXOD
FORWARD CLUTCH WAVE PLATE
USED 1986-1988**

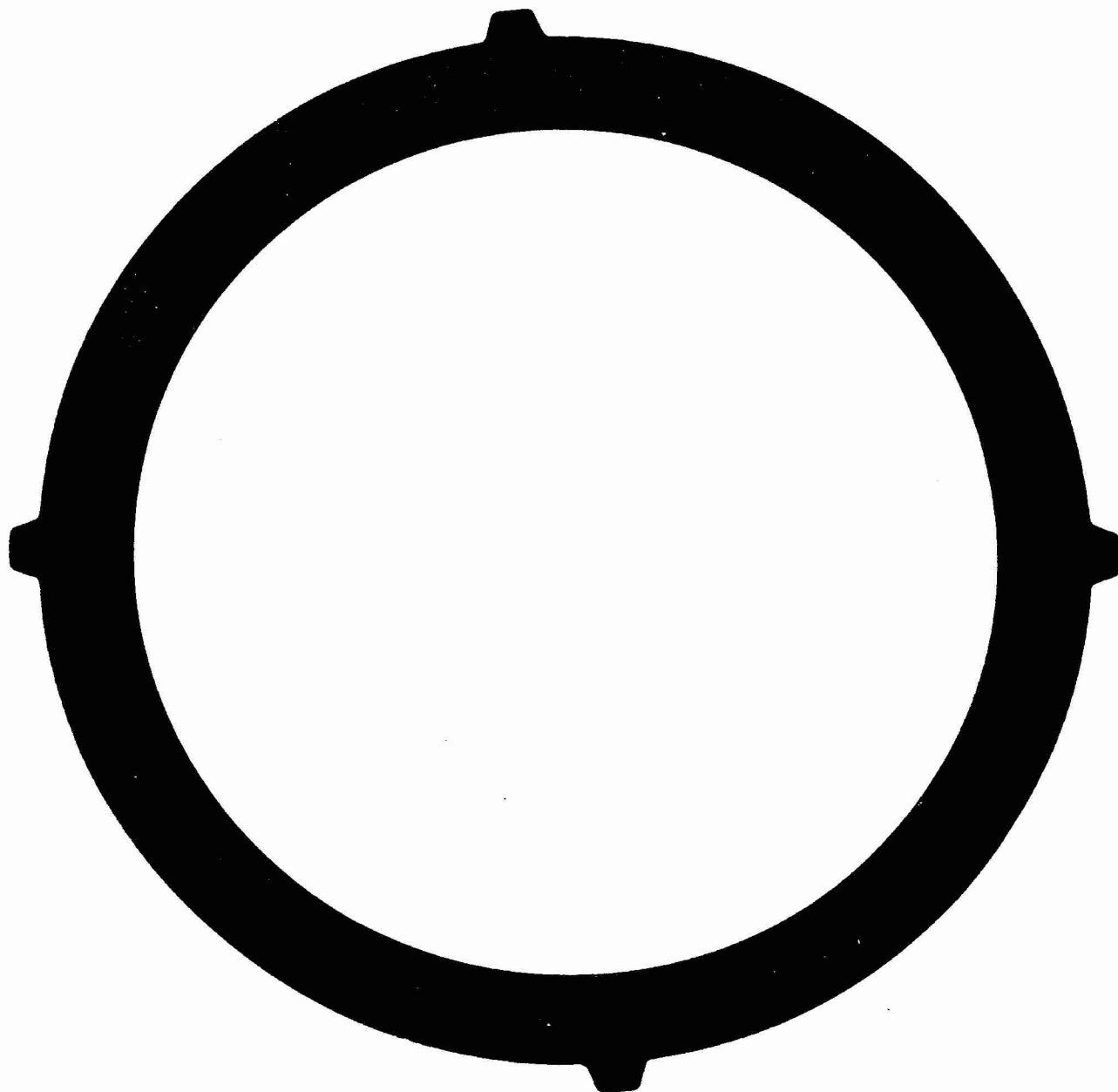

*4 External Teeth
Inside Diameter 4.715"
Material Is .062" Thick
Part Number E6DZ-7E085-B*

Copyright © 2002 ATSG

Figure 54



Technical Service Information

**FORD AXOD
FORWARD CLUTCH WAVE PLATE
USED 1989-1991**

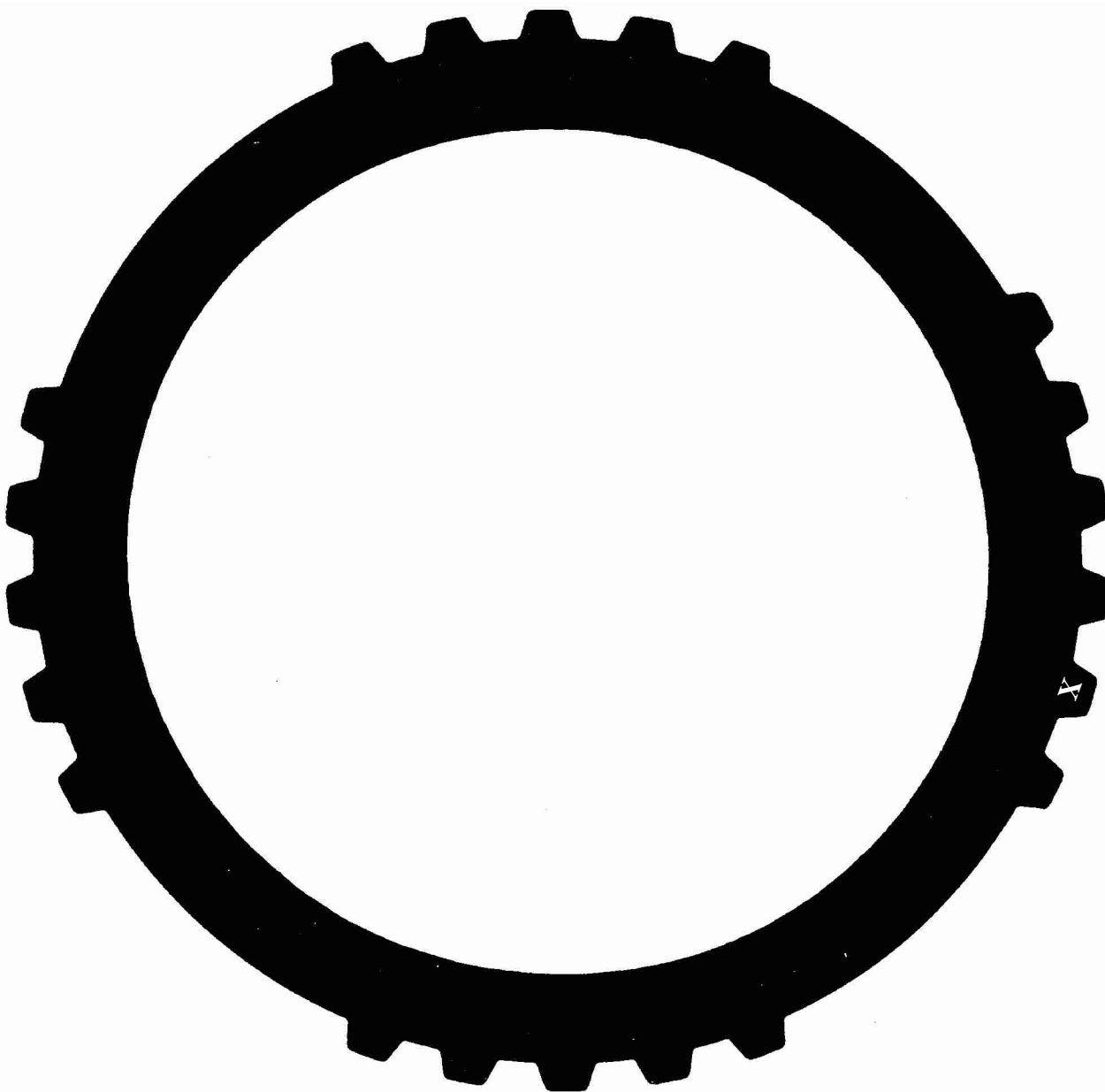

*21 External Teeth
Inside Diameter 4.730"
Material Is .075" Thick
I.D. Stamped "X" On 1 Tooth
Part Number F0DZ-7E085-A*

Copyright © 2002 ATSG

Figure 55



Technical Service Information

**FORD AXOD
FORWARD CLUTCH WAVE PLATE
USED 1992 AND LATER**

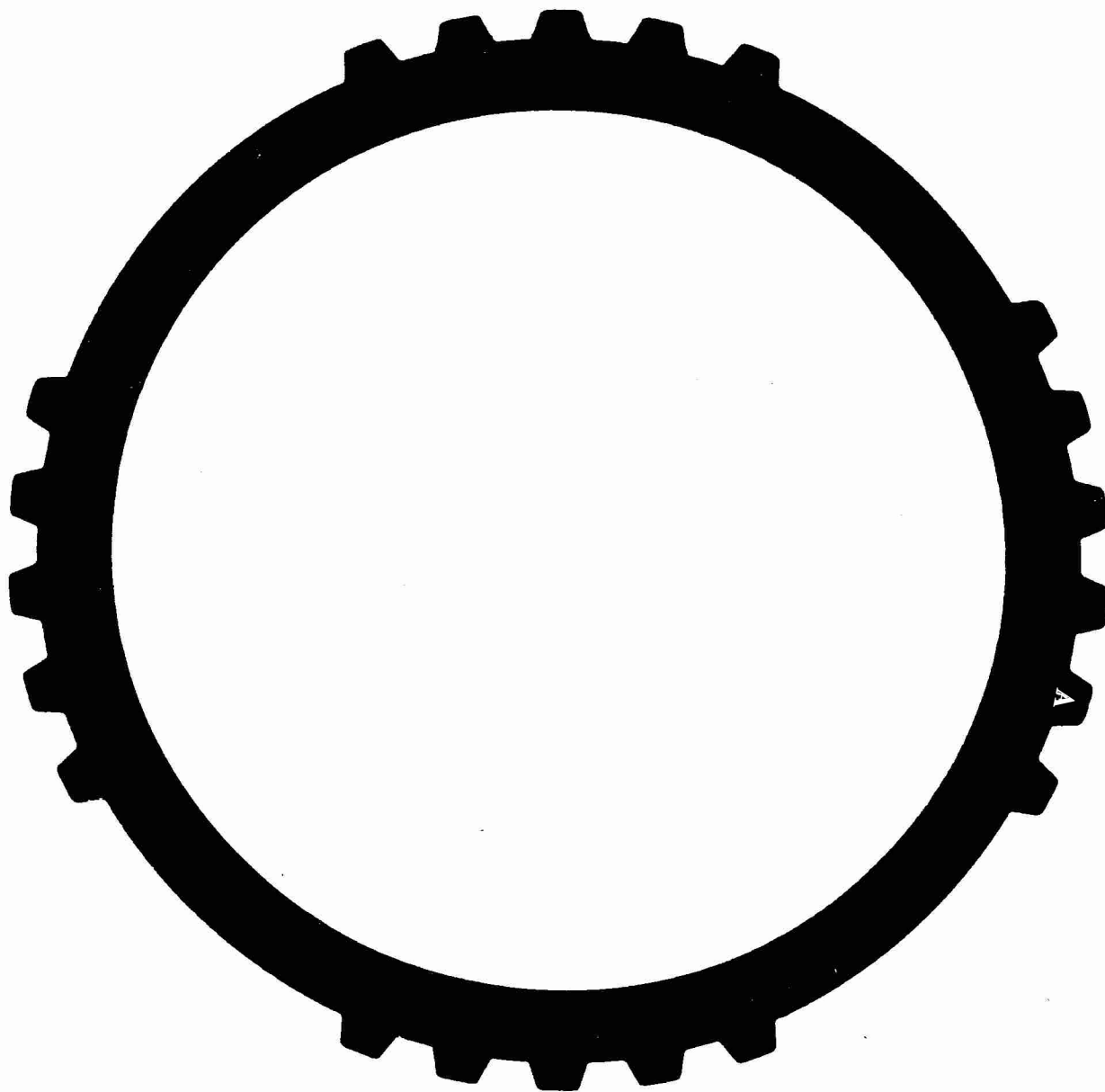

*21 External Teeth
Inside Diameter 4.930"
Material Is .083" Thick
I.D. Stamped "A" On 1 Tooth
Part Number F2DZ-7E085-A*

Copyright © 2002 ATSG

Figure 56



Technical Service Information

FORD AXOD/AXODE FORWARD CLUTCH PACK CHANGE LOW SPRAG OUTER RACE CHANGE

CHANGE: Beginning at start of production for 1992 models, all AXODE transaxles were built with a revised low sprag outer race that required revisions on the forward clutches, both lined and steel plates, a new pressure plate and "Wave" plate.

REASON: Improved durability and reliability of the low sprag outer race.

PARTS AFFECTED:

- (1) LOW SPRAG OUTER RACE - The outer diameter of the race was increased from 4.575" to 4.825", and the width of the race was increased from .600" to .725", as shown in Figure 57. *The Inside Diameter of the sprag race Did Not Change.*
- (2) FORWARD CLUTCH FRICTION PLATES - Have an increased amount of teeth to 57 Teeth from the previous 52 Teeth, to accommodate the increased diameter of the sprag outer race, as shown in Figure 58.
- (3) FORWARD CLUTCH STEEL PLATES - Have an increased inside diameter to 4.920" from the previous 4.720", to accommodate the increased diameter of the sprag outer race, as shown in Figure 59.
- (4) FORWARD CLUTCH PRESSURE PLATE - Has an increased inside diameter to 4.930" from the previous 4.730", to accommodate the increased diameter of the sprag outer race, as shown in Figure 60.
- (5) FORWARD CLUTCH "WAVE" PLATE - Has an increased inside diameter to 4.930" from the previous 4.730", to accommodate the increased diameter of sprag outer race (See Figure 61).

INTERCHANGEABILITY:

None of the parts listed above are interchangeable with previous design parts. If the sprag outer race is upgraded to the latest design, the forward clutch components *must* also be upgraded to the latest design level.

When *all* of the above parts are changed as a service package, they *will* retro-fit back to *all* previous model AXOD/AXODE transaxles.

SERVICE INFORMATION:

Forward Clutch Friction Plates (2nd Design)	F2DZ-7B164-A
Forward Clutch Steel Plates (2nd Design)	F2DZ-7B442-A
Forward Clutch "Wave" Plate (2nd Design)	F2DZ-7E085-A
Forward Clutch Pressure Plate (2nd Design)	F2DZ-7B066-A
Forward Clutch Overhaul Kit (Includes Low Sprag Outer Race)	F2DZ-7D171-A

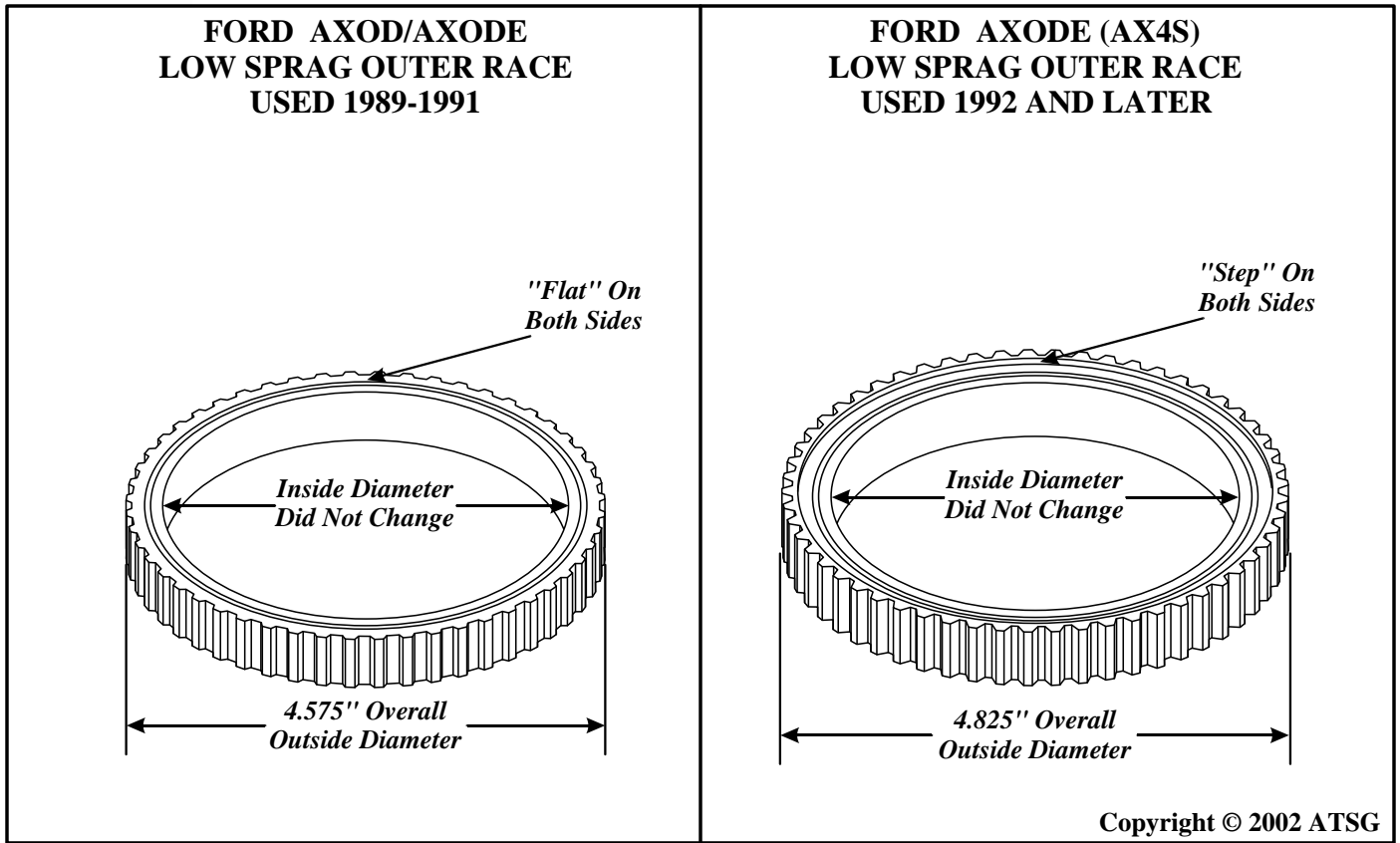

Figure 57

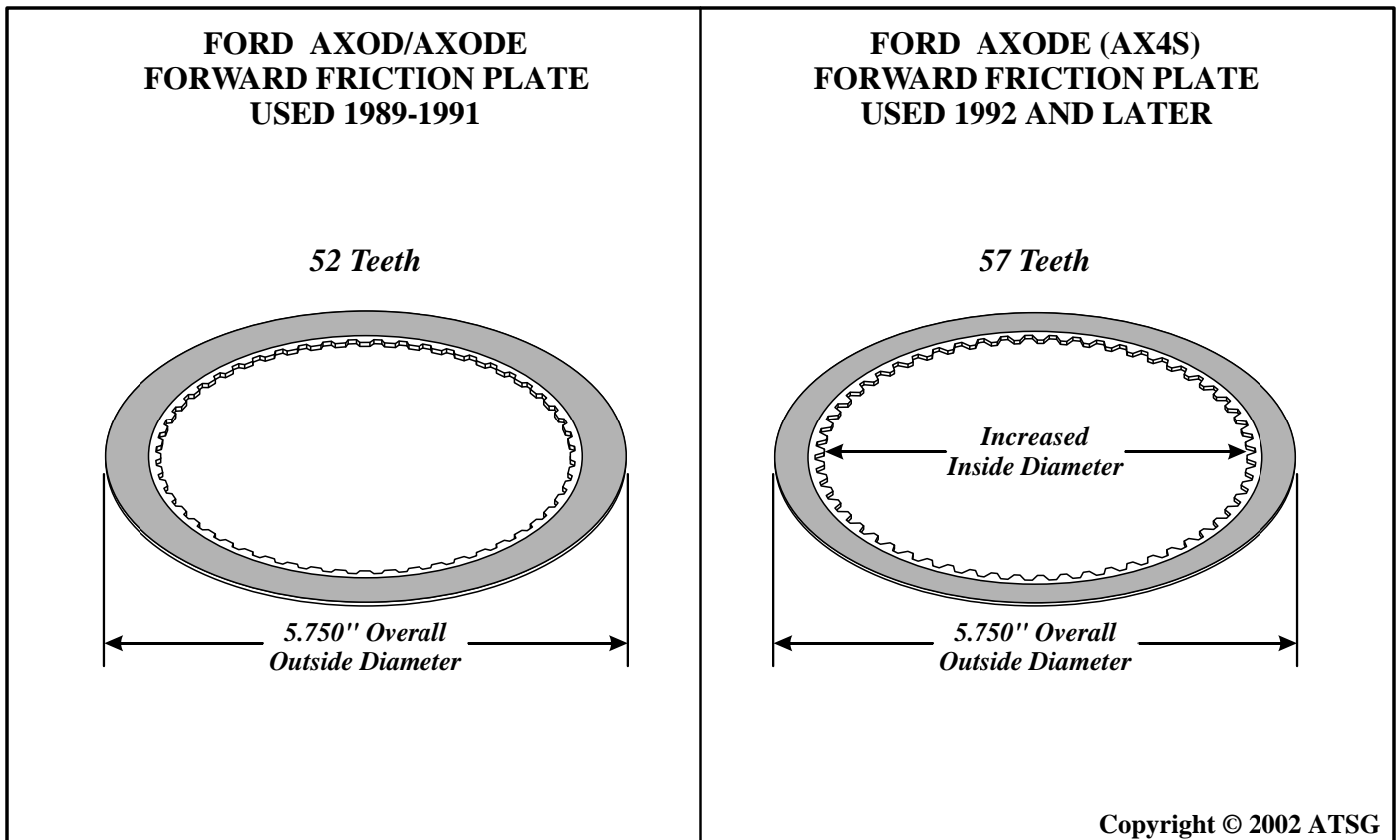

Figure 58

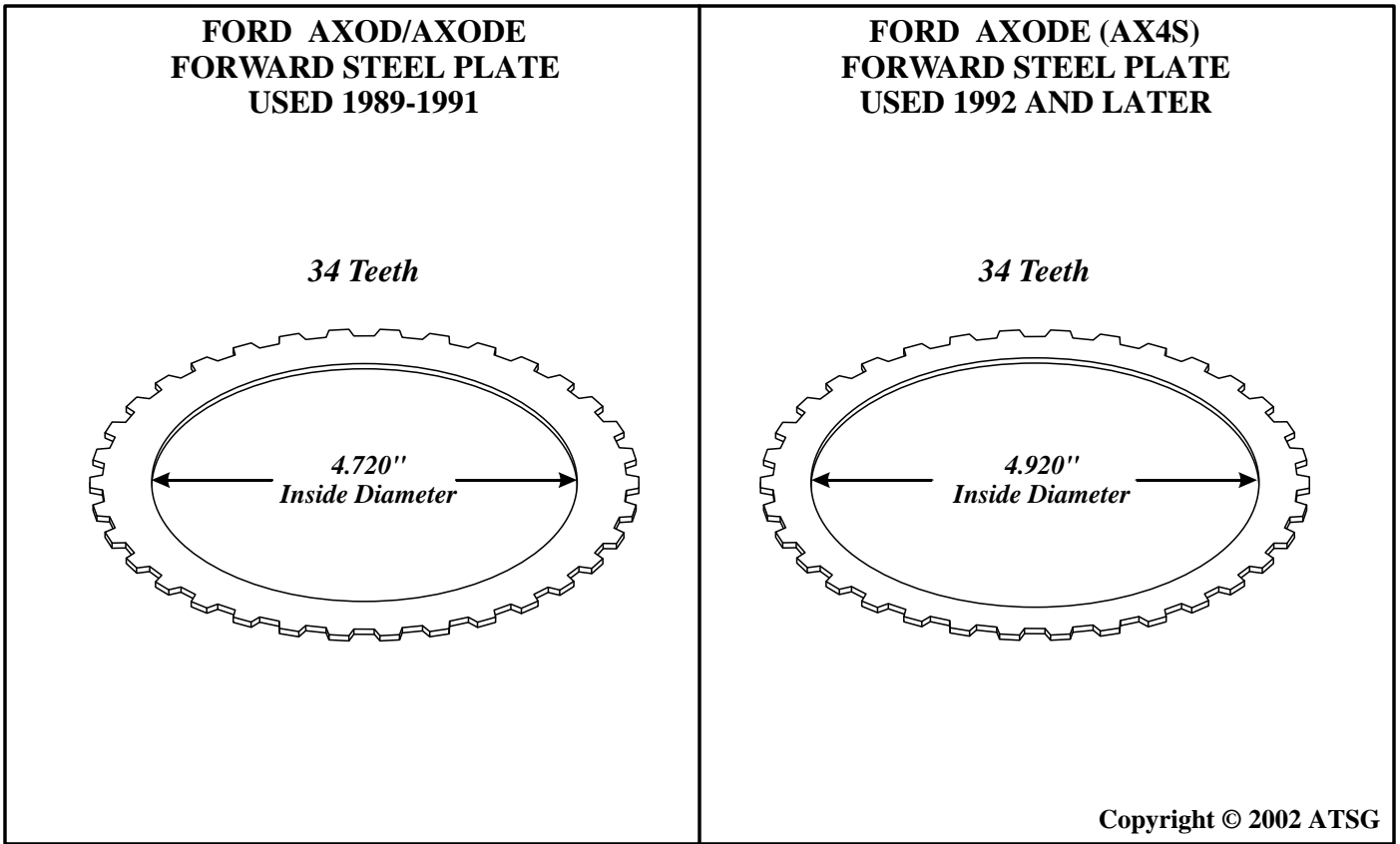

Figure 59

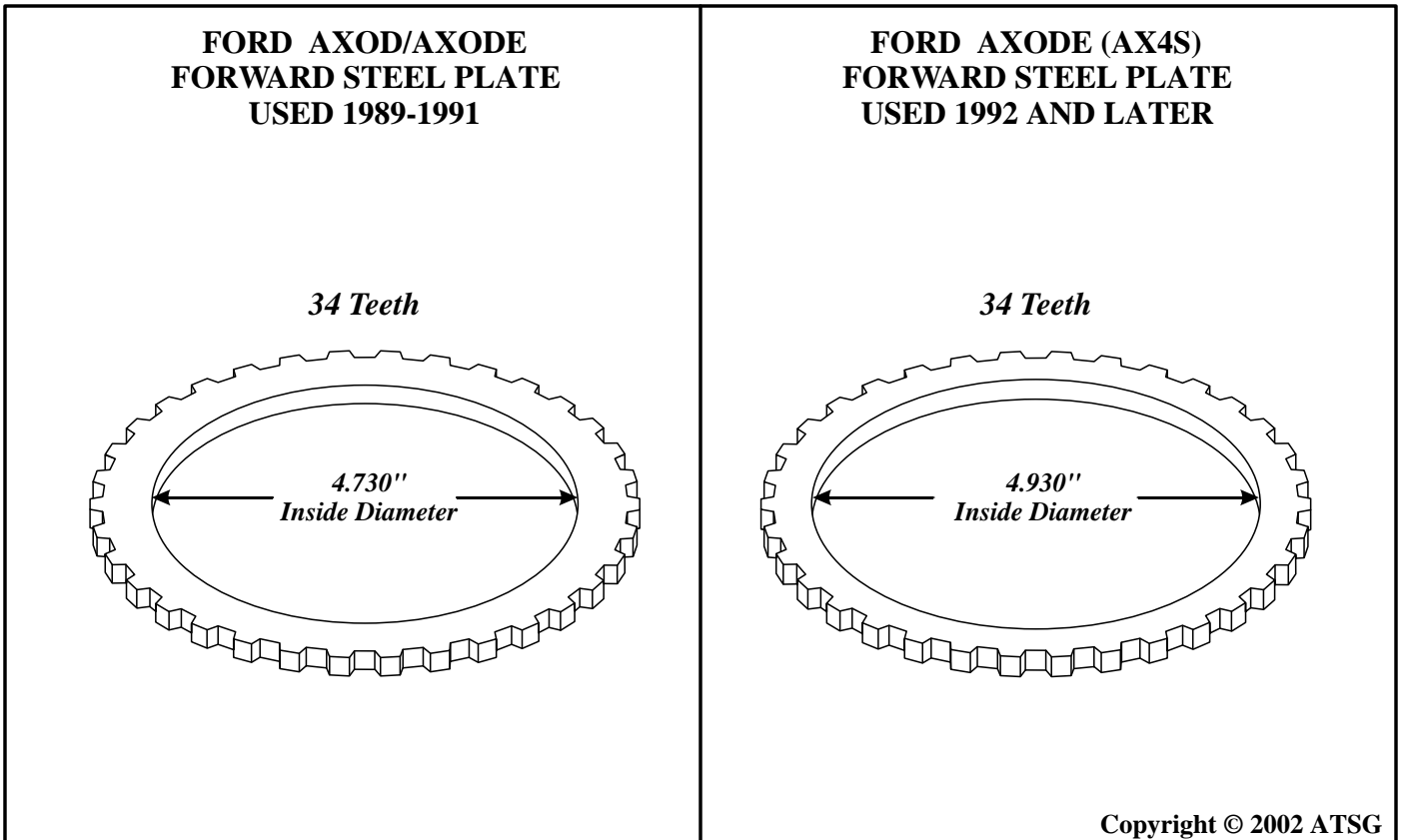
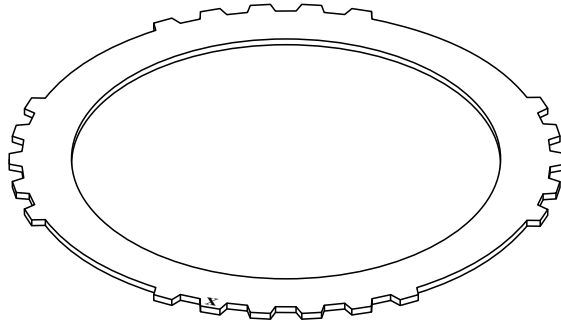

Figure 60



**FORD AXOD/AXODE
FORWARD "WAVE" PLATE
USED 1989-1991**



*21 External Teeth
Inside Diameter 4.730"
Material Is .075" Thick
I.D. Stamped "X" On 1 Tooth
Part Number F0DZ-7E085-A*

**FORD AXODE (AX4S)
FORWARD "WAVE" PLATE
USED 1992 AND LATER**

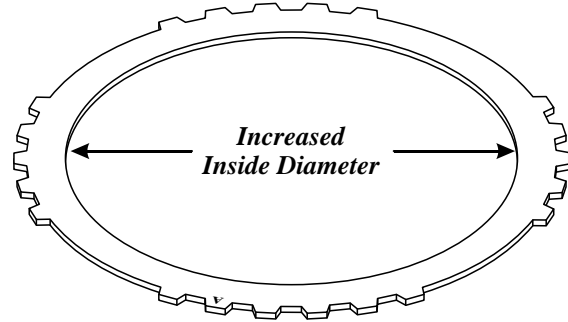

*21 External Teeth
Inside Diameter 4.930"
Material Is .083" Thick
I.D. Stamped "A" On 1 Tooth
Part Number F2DZ-7E085-A*

Copyright © 2002 ATSG

Figure 61



Technical Service Information

FORD AXOD/AXODE NEW DESIGN INPUT PLANETARY CARRIER AND SUN GEAR AND SHELL ASSEMBLY

CHANGE: Beginning at start of production for 1992 models, all AXODE transaxles were built with a new caged needle bearing added to the shaft on the Input Planetary Carrier, which also required a change on the Sun Gear and Shell assembly.

REASON: To better stabilize the sun gear and shell assembly for improved durability and reliability, of center gearbox concerns.

PARTS AFFECTED:

- (1) INPUT PLANETARY CARRIER - New caged needle Bearing added to the shaft on the Input Planetary Carrier, as shown in Figure 62.
- (2) SUN GEAR AND SHELL ASSEMBLY - Single bushing is now located in front of the lube holes in the sun gear, and the area behind is now machined to accommodate the new caged needle bearing, as shown in Figure 63.

INTERCHANGEABILITY:

The new design parts listed above will back service all previous models, ***but must be used together as a set.***

The new design parts are not compatible with the previous design parts.

SERVICE INFORMATION:

When you order an Input Planetary Carrier and/or a Sun Gear and Shell assembly from OEM, they will automatically supersede to the new service package part number F4DZ-7A398-A, which includes both of the new design parts listed above.



NEW DESIGN INPUT PLANETARY CARRIER

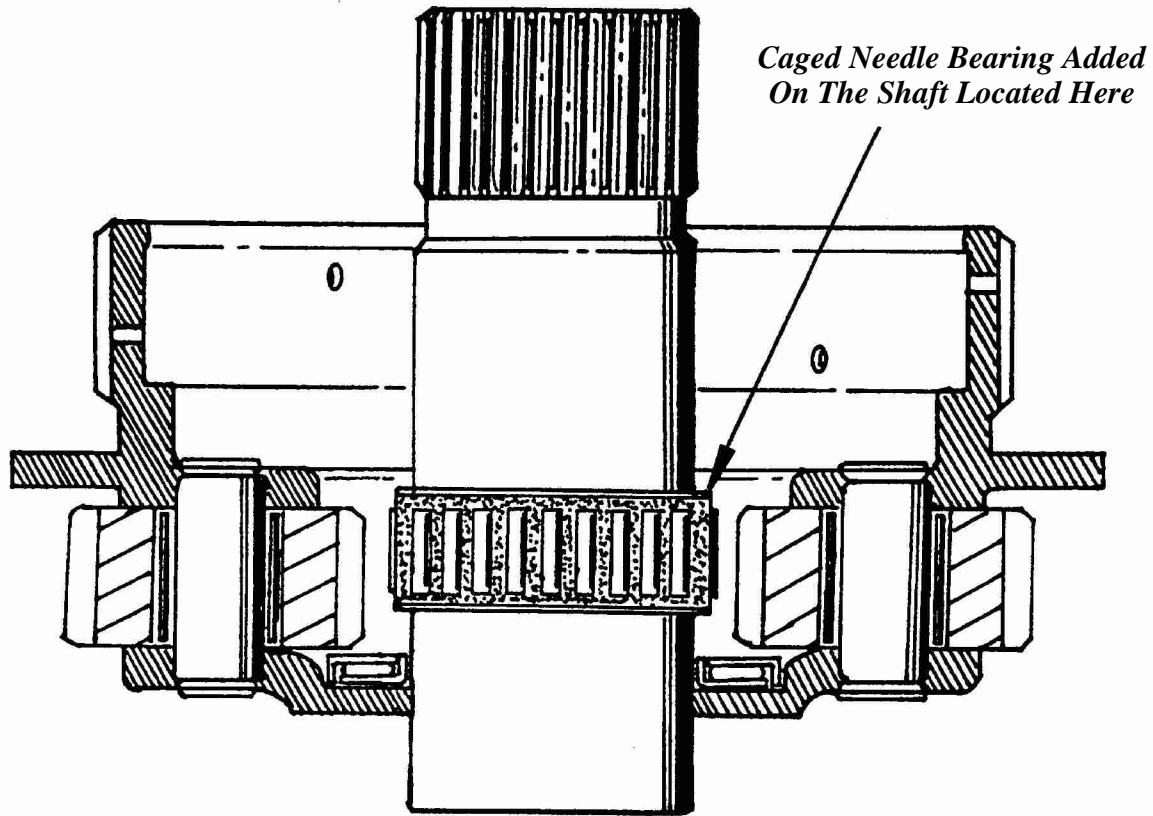

Copyright © 2002 ATSG

Figure 62



PREVIOUS DESIGN SUN GEAR AND SHELL

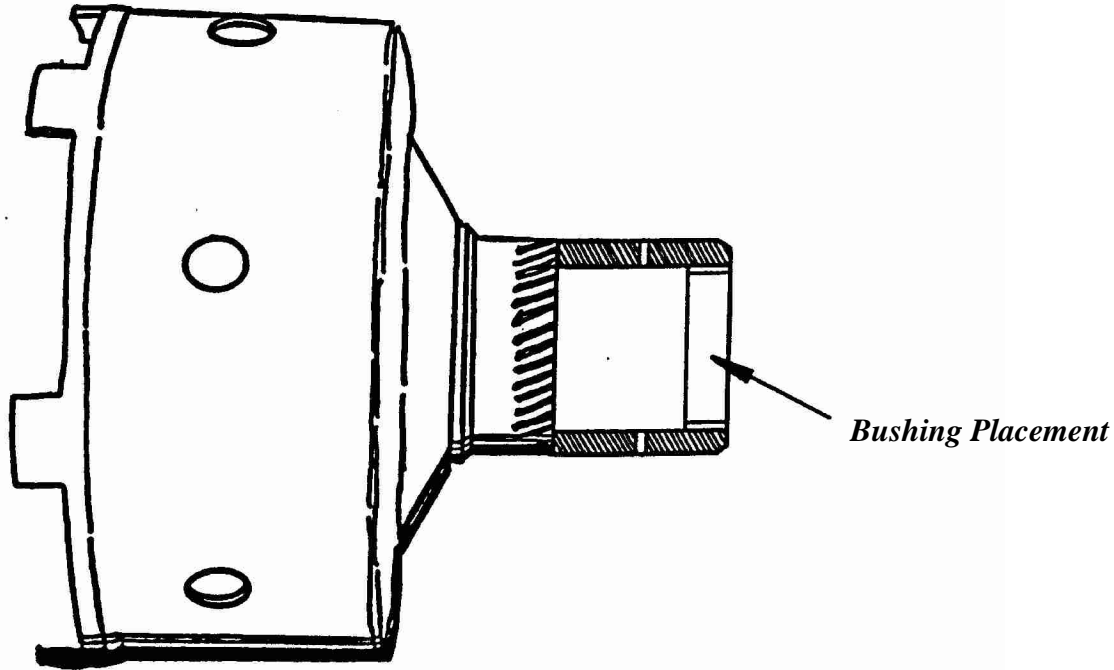

NEW DESIGN SUN GEAR AND SHELL

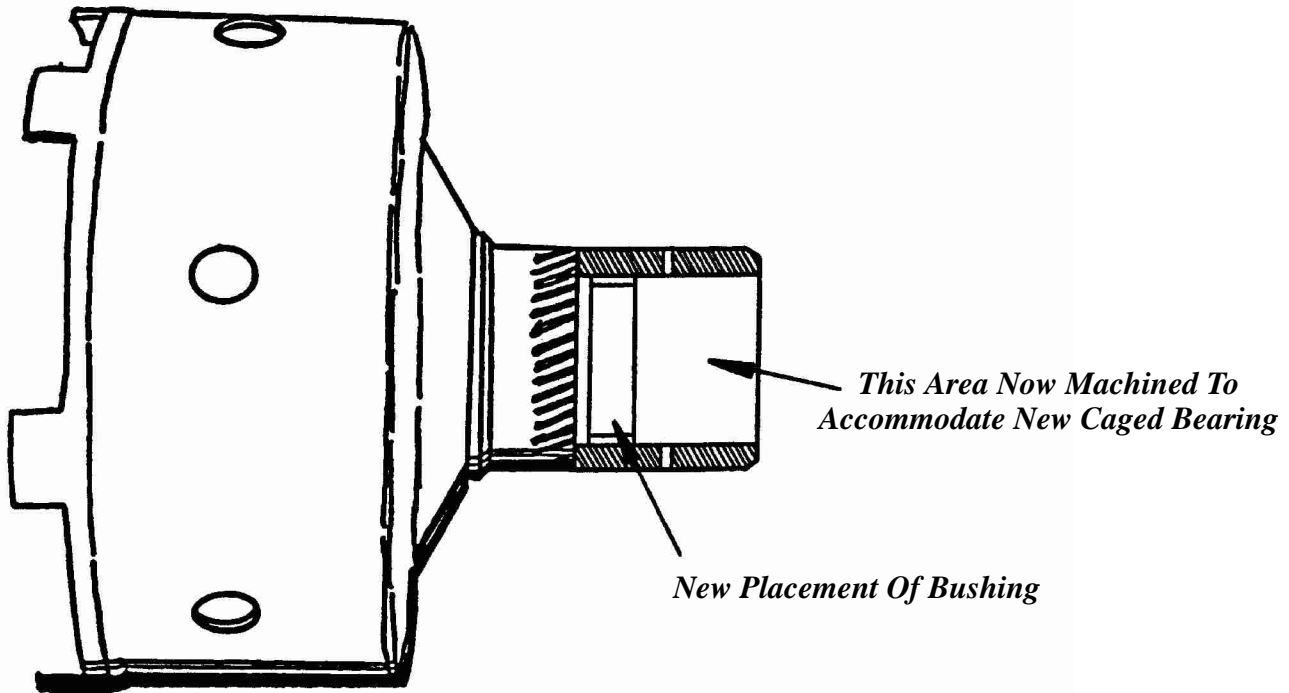

Copyright © 2002 ATSG

Figure 63



Technical Service Information

FORD AXOD/AXOD-E

NO MOVEMENT OR NO CONVERTER CLUTCH

COMPLAINT: Before and/or after rebuild, the vehicle exhibits one of the following conditions:

1. *"No Movement" in forward or reverse.*
2. *"No Converter Clutch" apply at any speed.*

CAUSE: The cause may be, one of the following:

1. *The converter feed passage in the Oil Pump Drive Shaft blocked with debris or was not machined properly to allow converter feed oil to enter the converter.*
2. *The Oil Pump Drive Shaft leaking or not machined properly, allowing converter feed passage and converter release passage to be connected.*

CORRECTION: Refer to Figure 64 to *check* the Oil Pump Drive Shaft, and clean or replace as necessary.

NOTE: *We have seen some replacement shafts, both reman and new that were leaking between the converter apply and release passages.*

SERVICE INFORMATION:

Oil Pump Drive Shaft (AXOD/AXODE) E6DZ-7B328-A

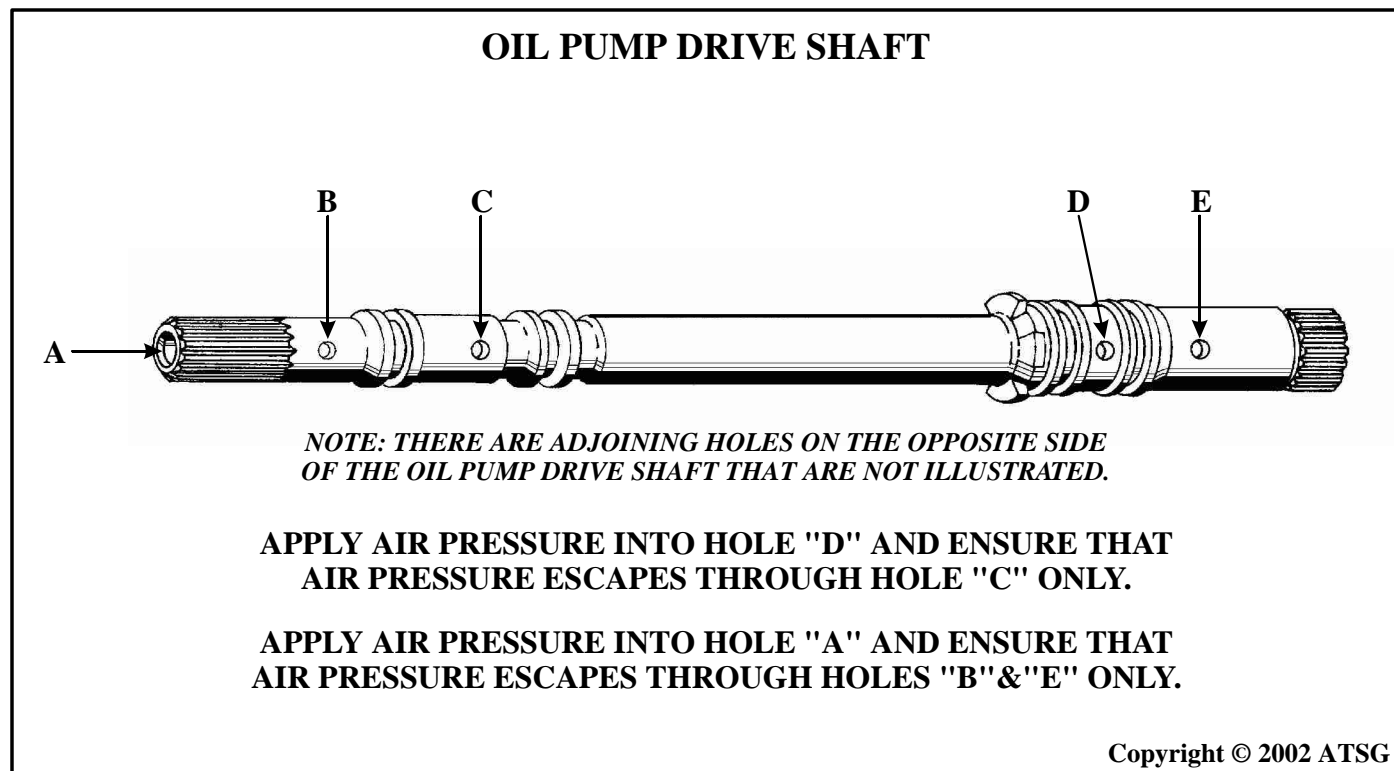

Figure 64



Technical Service Information

**THE REMAINDER OF THIS MANUAL WILL BE
DEDICATED TO THE AXODE TRANSAXLE**

FORD AXODE OIL PUMP CHECKBALL LOCATION CHANGES

<i>Vehicle Line</i>	<i>Up To And Including Serial Number</i>	<i>Model Code</i>
<i>1991 Taurus/Sable 3.8L</i>	<i>54553</i>	<i>PNA-EA</i>
<i>1991 Taurus/Sable 3.0L</i>	<i>195343</i>	<i>PNA-EC</i>
<i>1991 Continental 3.8L</i>	<i>39653</i>	<i>PNA-EB</i>
<i>1991 All Police 3.8L</i>	<i>10936</i>	<i>PNA-EE</i>

"Early" 1991 Only - Uses 5 checkballs in the locations shown in Figure 65. Use chart above to determine Early or Late transaxle by serial number.

"Late" 1991 Only - Uses 4 checkballs in the locations shown in Figure 65. Use chart above to determine Early or Late transaxle by serial number.

1992-1998 Only - Uses 4 checkballs but in different locations, as shown in Figure 66. B-13 checkball was eliminated and B-2 checkball was added.

1999-2002 Only - Uses 3 checkballs in the locations shown in Figure 66. B-5 checkball was eliminated.



CHECKBALL LOCATIONS "EARLY" 1991 "ONLY"

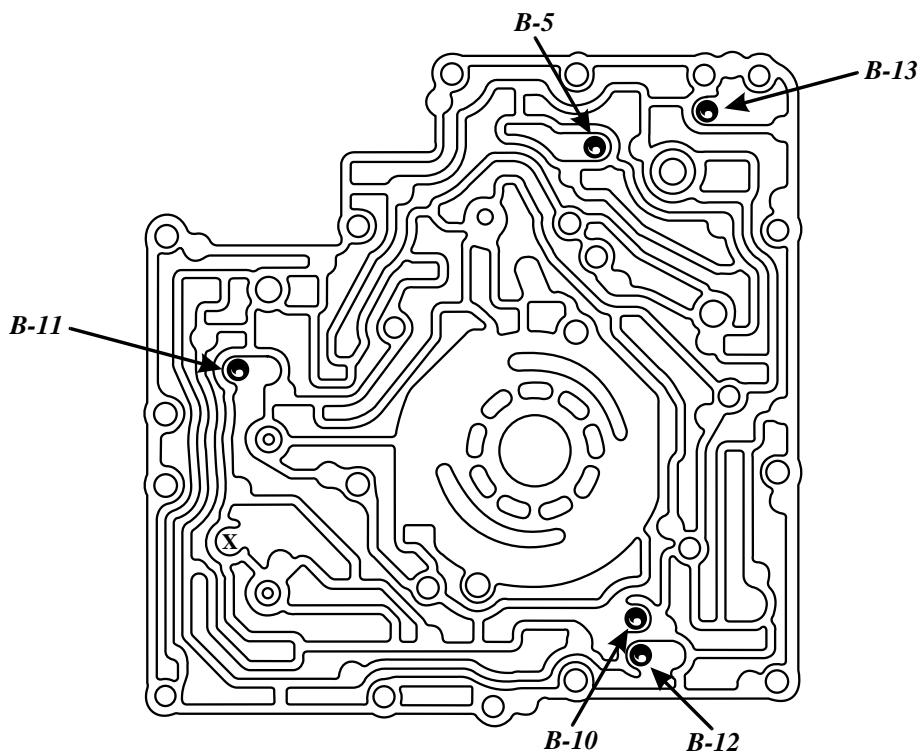

CHECKBALL LOCATIONS "LATE" 1991 "ONLY"
CHECKBALL LOCATIONS "LATE" 1991 "ONLY"

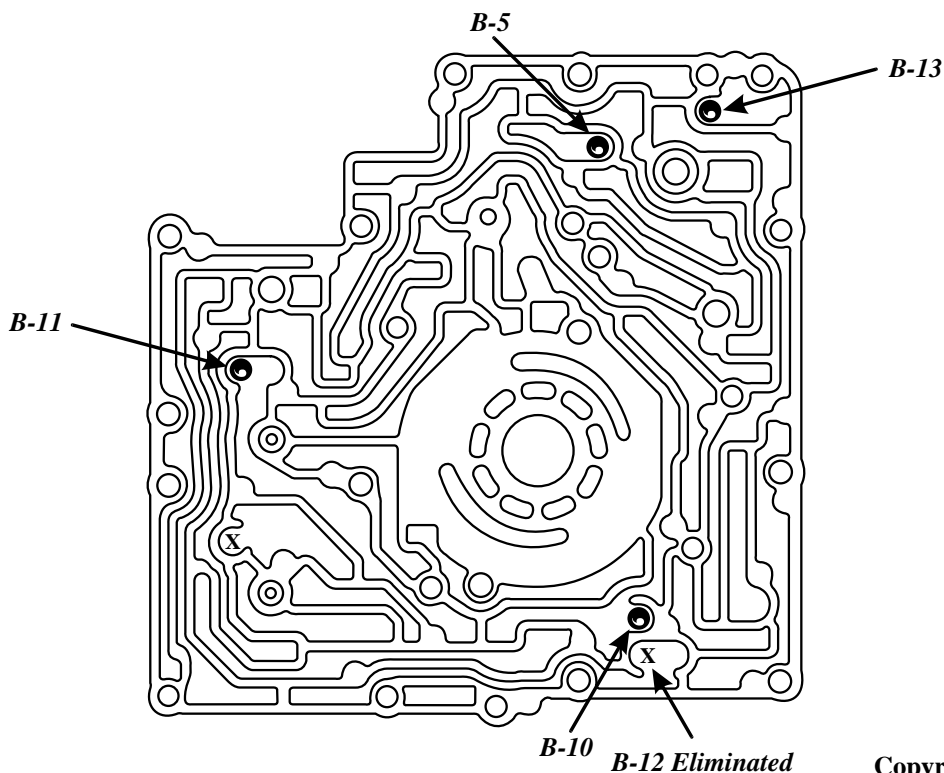

Copyright © 2002 ATSG

Figure 65



CHECKBALL LOCATIONS 92-98 MODELS "ONLY"

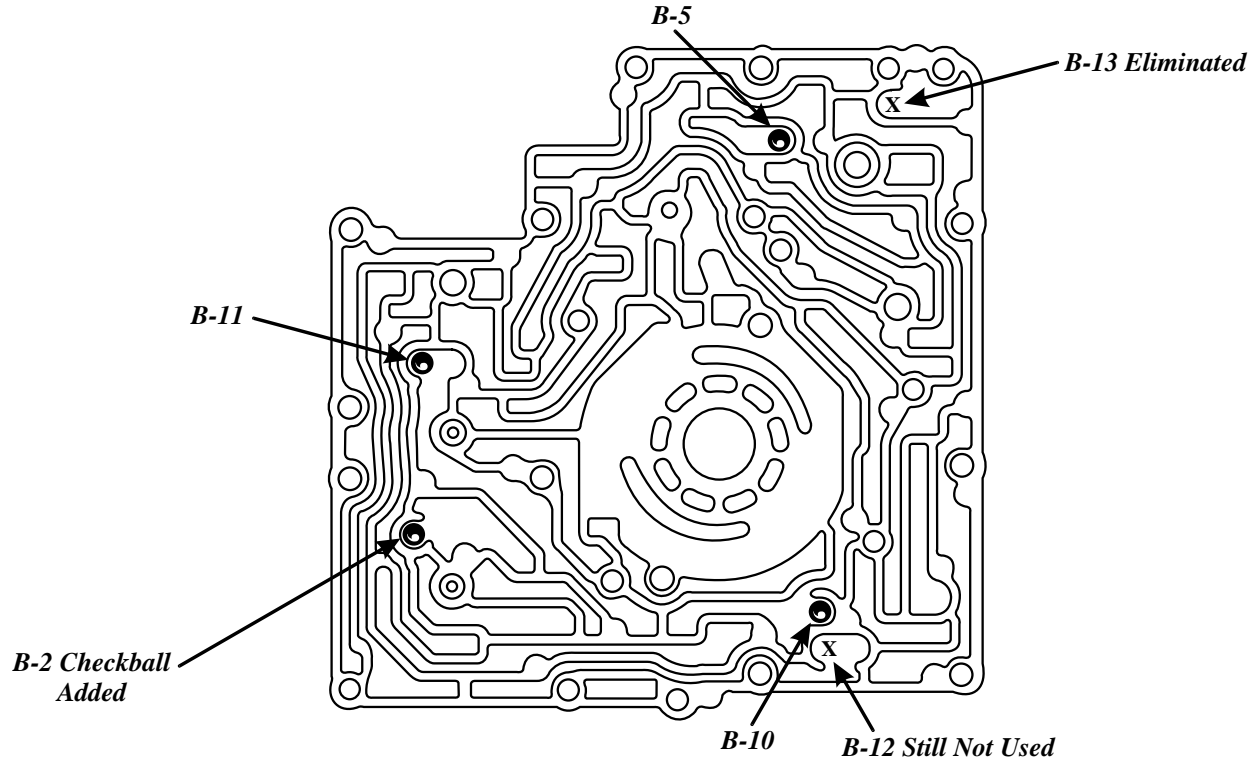

CHECKBALL LOCATIONS 1999 AND LATER "ONLY"

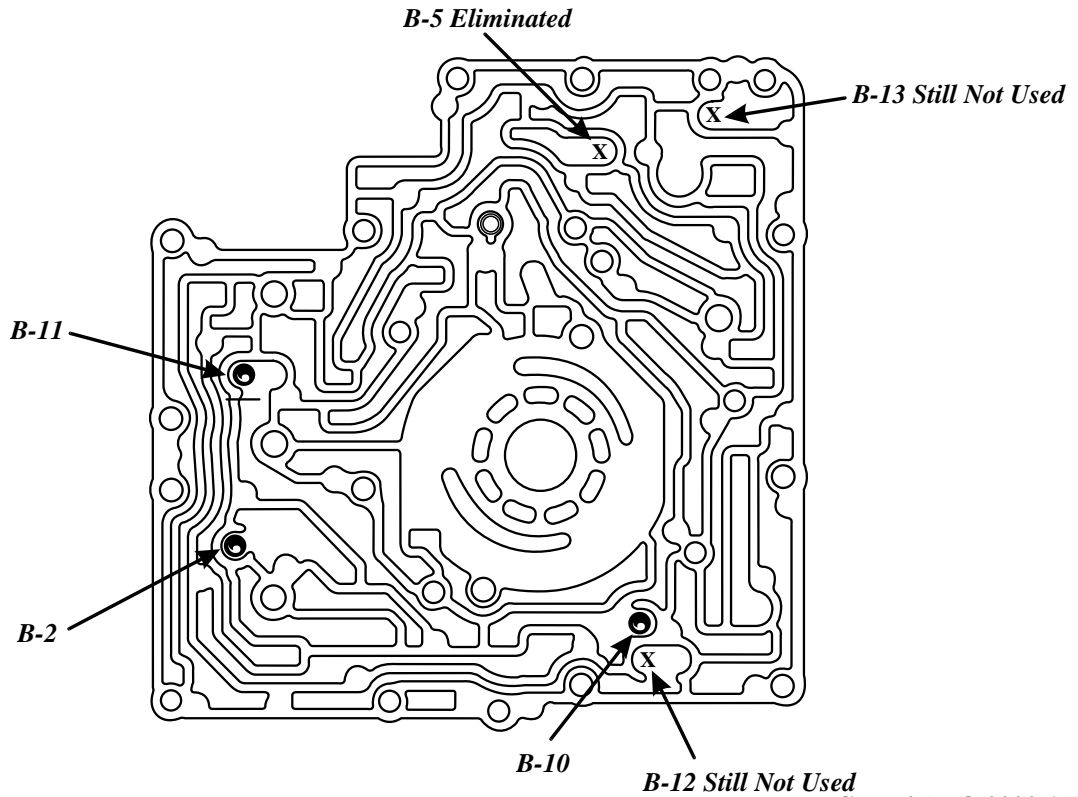

Copyright © 2002 ATSG

Figure 66



Technical Service Information

FORD AXOD/AXOD-E CONVERTER TURBINE SPLINES CHANGE FROM 23 TEETH TO 25 TEETH

CHANGE: Beginning on December 20, 1993, for the 1994 production schedule, Ford Motor Co. changed the converter turbine splines and the turbine shaft splines to 25 teeth from previous 23 splines.

REASON: Improved durability for higher torque applications.

PARTS AFFECTED:

- (1) **TORQUE CONVERTER** - Converter turbine splines changed from 23 splines to 25 splines. To identify this change, the converter "Stamp Code" was changed. Refer to the chart found in Figure 67 for identification, if the converter has not been rebuilt.
- (2) **TURBINE SHAFT** - Splines changed from 23 splines to 25 splines. Count the number of splines on turbine shaft for positive identification.

INTERCHANGEABILITY:

If replacement of either torque converter and/or turbine shaft is necessary, ensure that equal number of splines exist on the mating parts.

CAUTION: *It is possible to install a 25 Spline converter onto a 23 Spline turbine shaft. If this occurs, the vehicle will have a "No Movement" condition and after the engine is started will usually twist off the stator shaft (Drive Sprocket Support).*

*Two "Notches" 180 Degrees
Apart Indicate a 25 Tooth
Turbine Hub*

**INNER VIEW OF
CONVERTER HUB
OPENING**

1993-Back Models: Are 23 Spline From OEM

1994 Models Could Be Either

CONVERTER STAMP CODE (23 TEETH)	CONVERTER STAMP CODE (25 TEETH)
18 Or 36	19 Or 45
24 Or 37	28 Or 42
25 Or 38	29 Or 39
26 Or 43	30 Or 44
27 Or 40	31 Or 41

1995-Up Models: Are 25 Spline From OEM

***"Do Not" Use I.D. Stamp Code For
Identification If Converter Has Been
Re-Manufactured***

Copyright © 2002 ATSG

Figure 67



Technical Service Information

FORD AXODE VALVE BODY BORE NUMBERS AND VALVE IDENTIFICATION

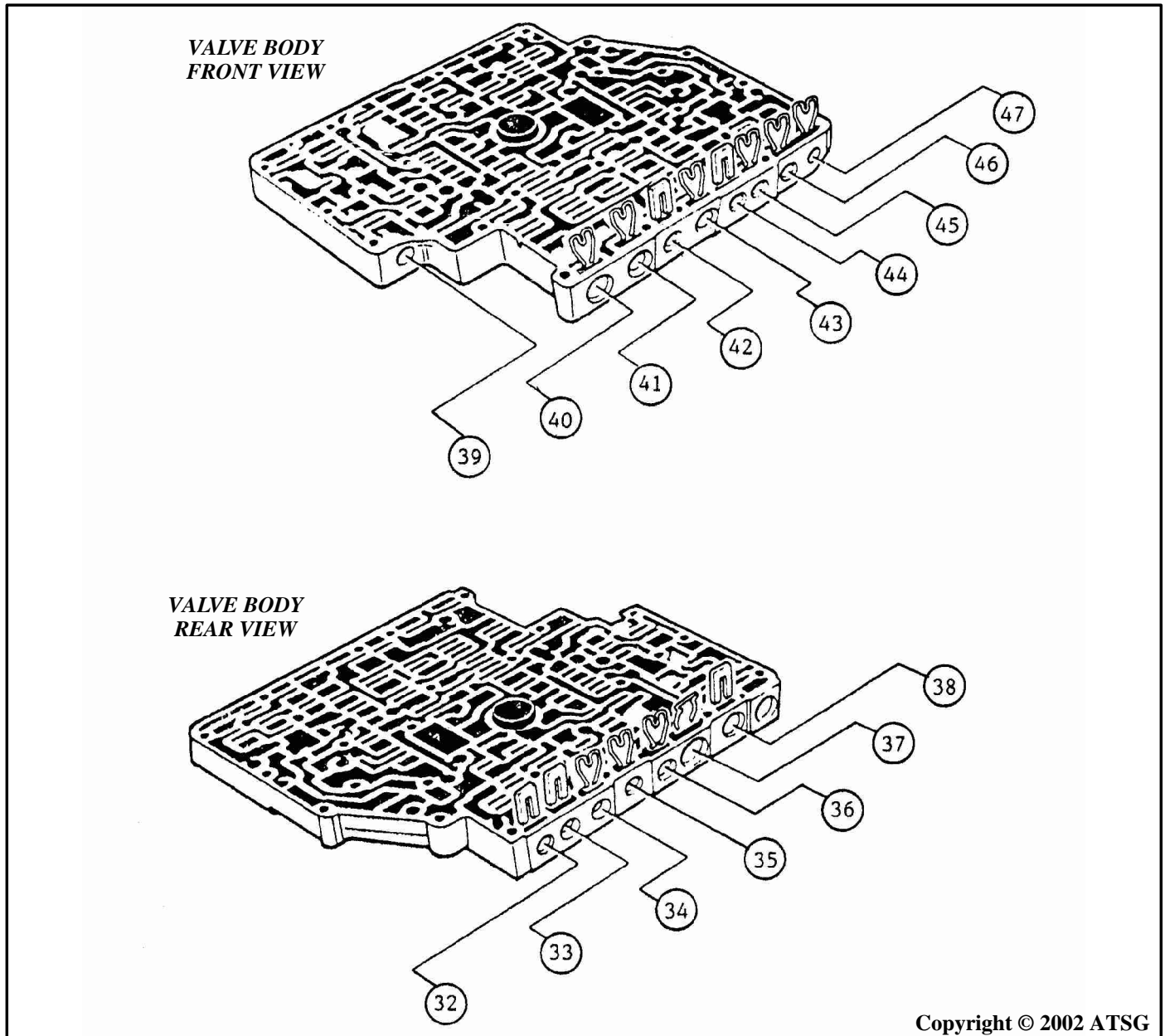

Figure 68

On this page we have assigned numbers to all of the valve body bores and re-drawn the valves and springs and placed them in their *proper* locations, with each valve oriented properly and the function identified, as shown on the following pages. Most of the manuals presently in print are wrong.

USE THIS MANUAL TO PROPERLY ASSEMBLE THE AXODE (AX4S) VALVE BODY

AUTOMATIC TRANSMISSION SERVICE GROUP



FORD AXODE

VALVE BODY BORE NUMBERS AND VALVE IDENTIFICATION

<i>Valve Body Bore Number</i>	<i>Valve Number</i>	<i>Description</i>
32	1	<i>Pressure Failsafe Valve</i>
33	2	<i>Backout Valve (Found In Early 1991 Only)</i>
33	3	<i>Backout Valve (Found In Late 1991 To Current Models)</i>
34	4	<i>Accumulator Regulator Valve Plunger</i>
34	5	<i>Accumulator Regulator Valve</i>
35	6	<i>1-2 Capacity Modulator Valve</i>
36	7	<i>Converter Clutch Control Valve Plunger</i>
36	8	<i>Converter Clutch Control Valve</i>
37	9	<i>Main Regulator Boost Valve Sleeve</i>
37	10	<i>Main Regulator Boost Valve</i>
37	11	<i>Main Regulator Valve (Note Direction Of Spring Seat)</i>
38	12	<i>Converter Clutch Regulator Valve</i>
38	13	<i>Shift Solenoid Regulator Valve</i>
39	14	<i>Manual Valve</i>
40	15	<i>2-3 Shift Valve</i>
41	16	<i>1-2 Shift Valve</i>
42	17	<i>Intermediate Clutch Shuttle Valve</i>
43	18	<i>3-4 Shift Valve</i>
44	19	<i>Forward Clutch Control Valve</i>
45	20	<i>Pull-In Control Valve</i>
45	21	<i>3-2 Control Valve (If Retainer Breaks, 3-Neutral Shift)</i>
46	22	<i>Neutral/Drive Engagement Control Valve</i>
47	23	<i>2-3 Servo Regulator Valve</i>

Copyright © 2002 ATSG

Figure 69

AUTOMATIC TRANSMISSION SERVICE GROUP

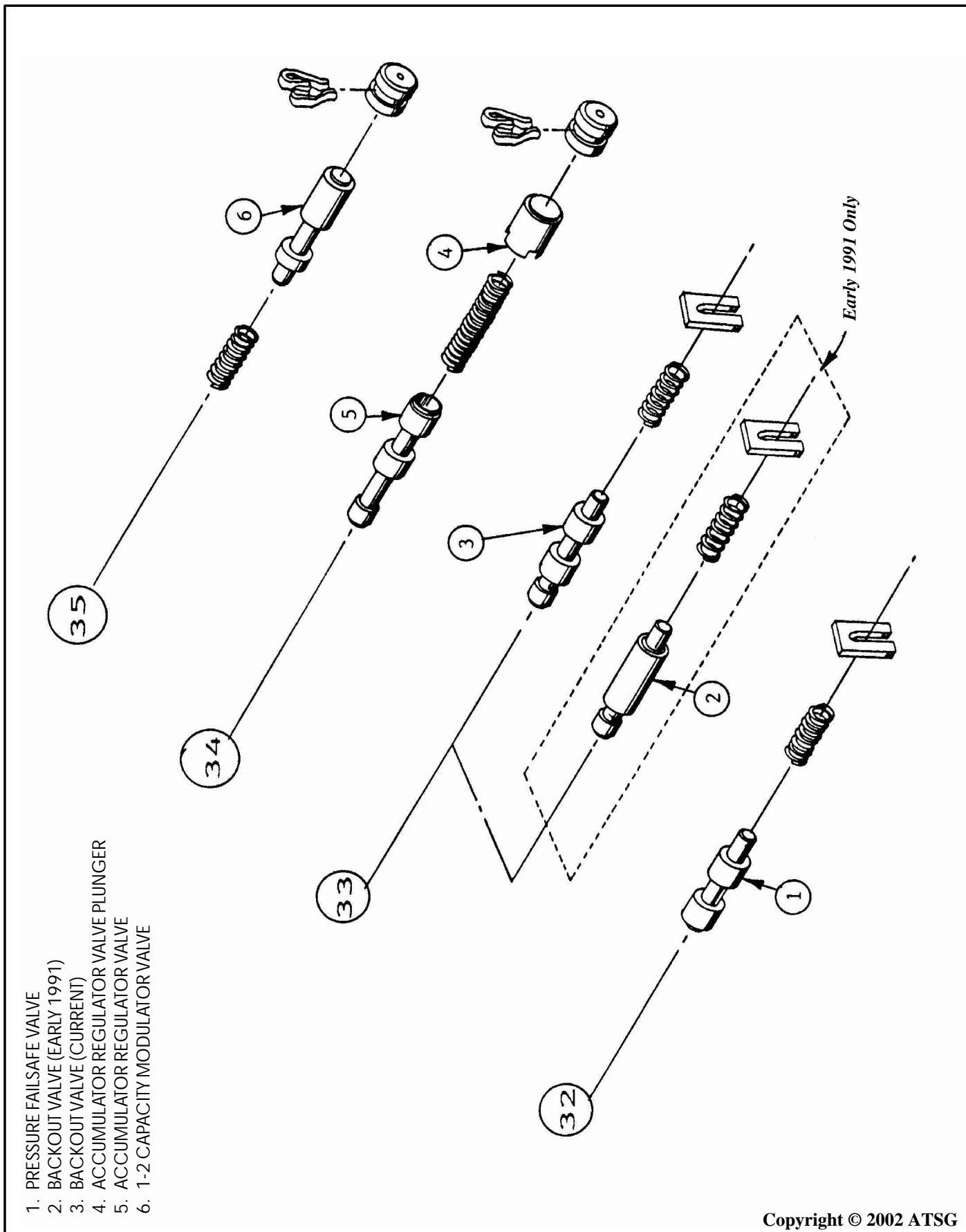

- 1. PRESSURE FAILSAFE VALVE
- 2. BACKOUT VALVE (EARLY 1991)
- 3. BACKOUT VALVE (CURRENT)
- 4. ACCUMULATOR REGULATOR VALVE PLUNGER
- 5. ACCUMULATOR REGULATOR VALVE
- 6. 1-2 CAPACITY MODULATOR VALVE

Copyright © 2002 ATSG

Figure 70

AUTOMATIC TRANSMISSION SERVICE GROUP

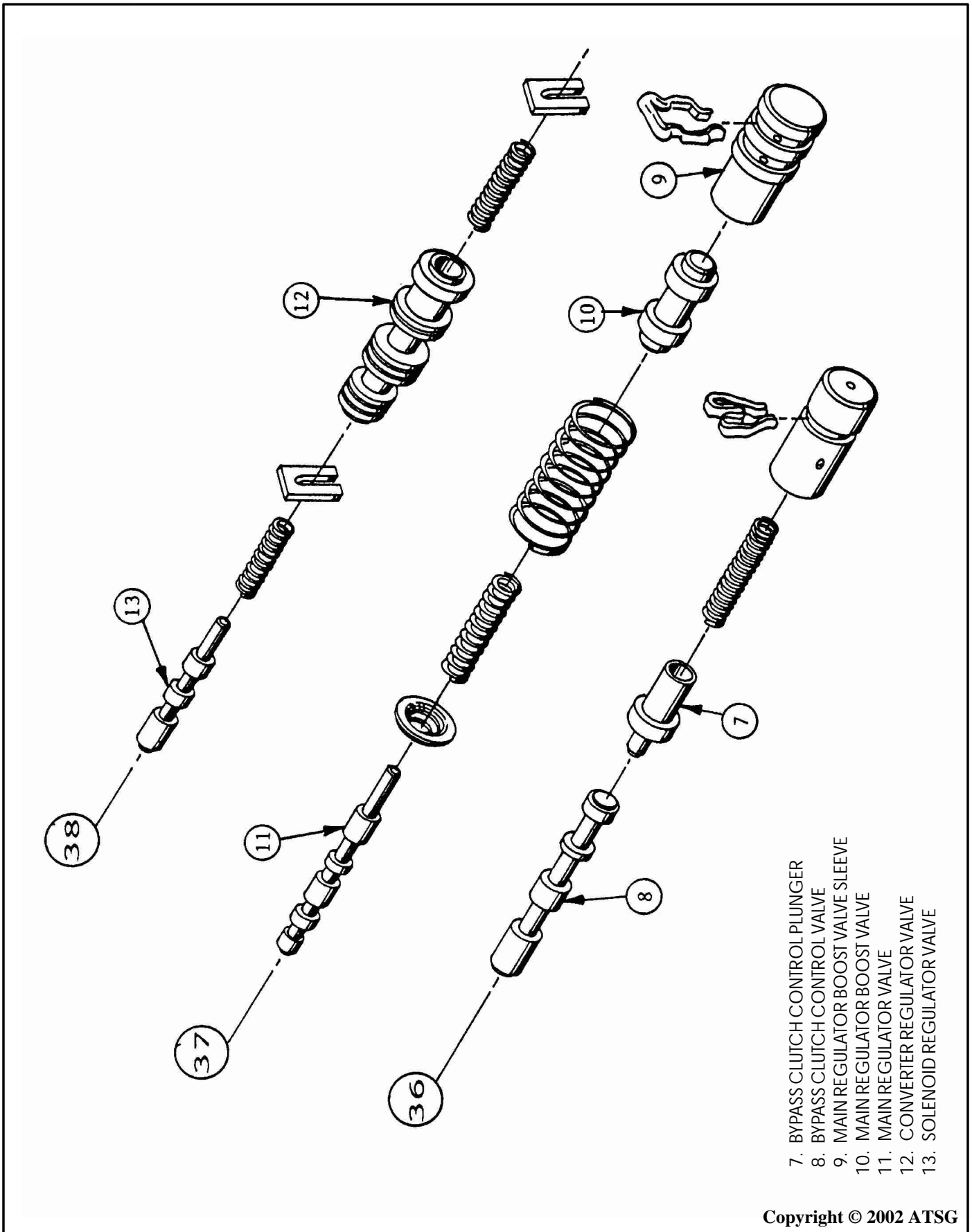

- 7. BYPASS CLUTCH CONTROL PLUNGER
- 8. BYPASS CLUTCH CONTROL VALVE
- 9. MAIN REGULATOR BOOST VALVE SLEEVE
- 10. MAIN REGULATOR BOOST VALVE
- 11. MAIN REGULATOR VALVE
- 12. CONVERTER REGULATOR VALVE
- 13. SOLENOID REGULATOR VALVE

Copyright © 2002 ATSG

Figure 71
AUTOMATIC TRANSMISSION SERVICE GROUP

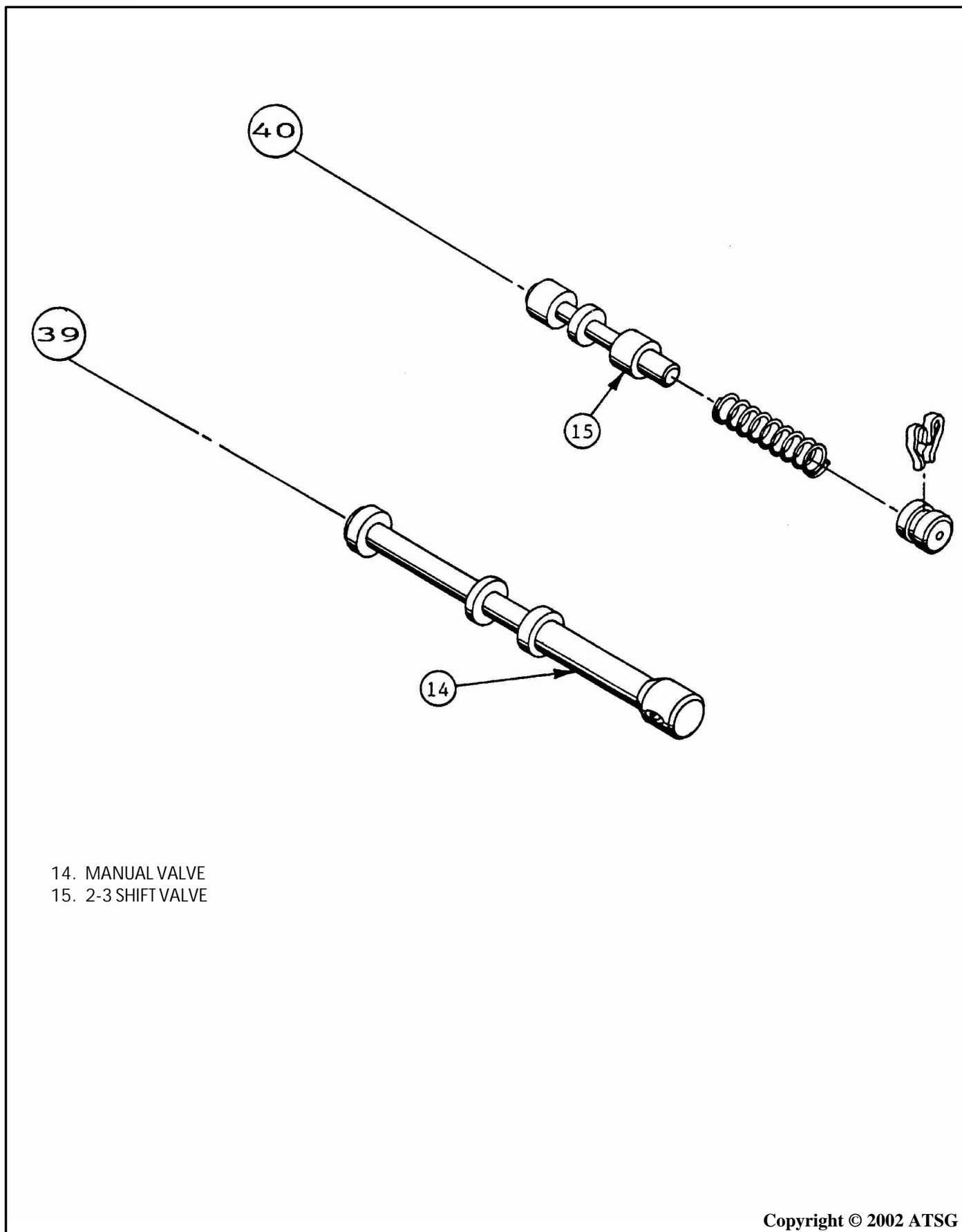
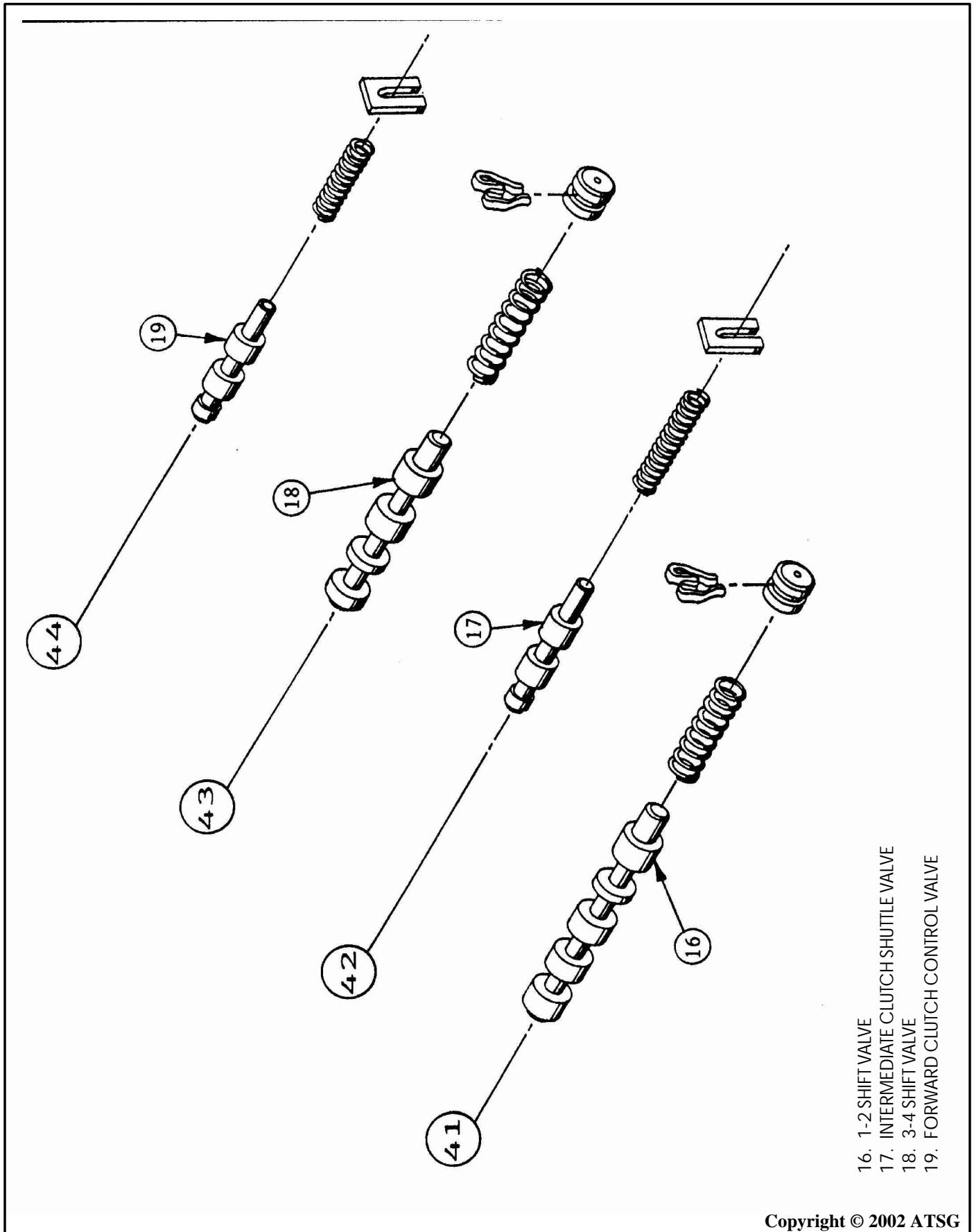

Figure 72

AUTOMATIC TRANSMISSION SERVICE GROUP



Copyright © 2002 ATSG

Figure 73

AUTOMATIC TRANSMISSION SERVICE GROUP

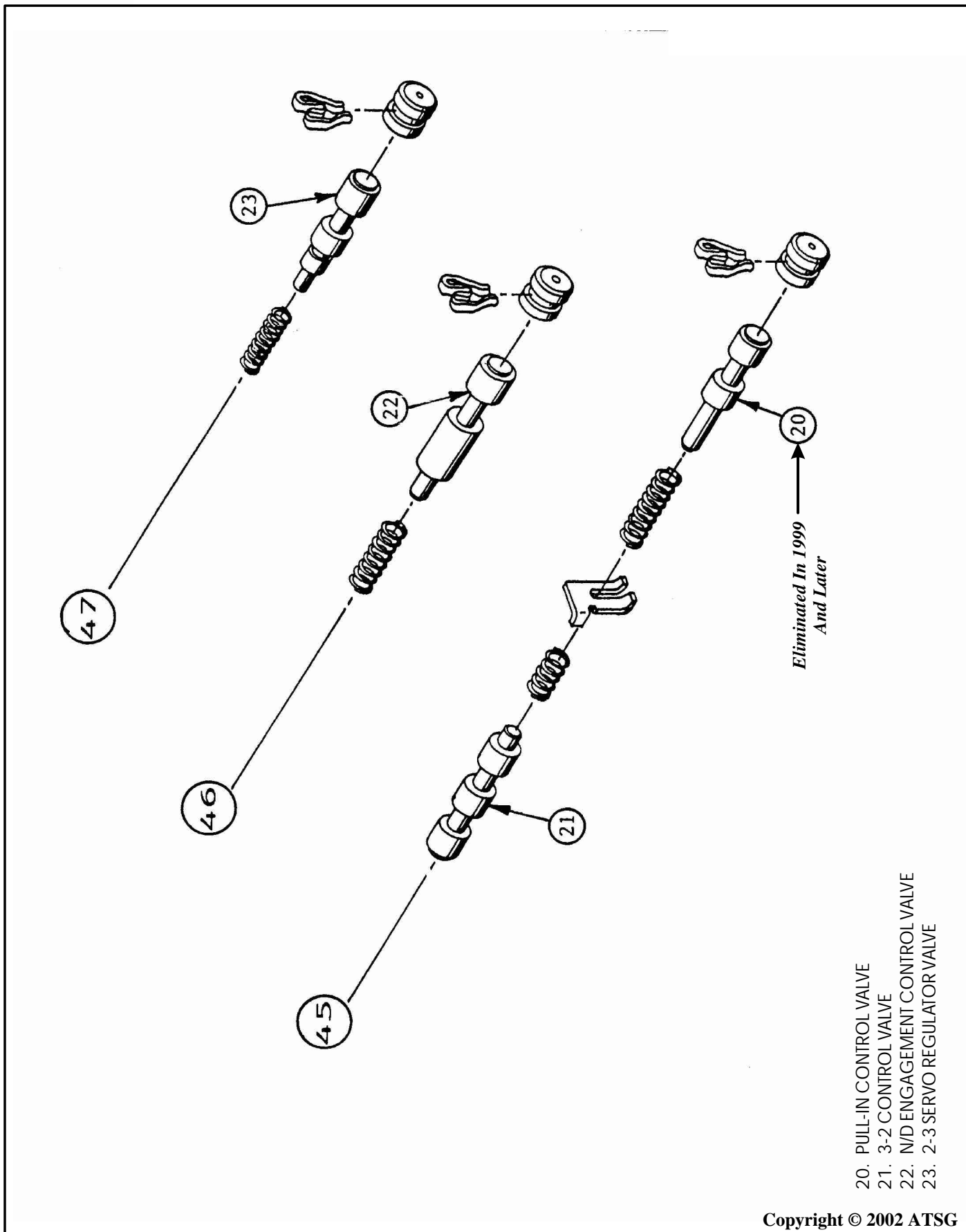

- 20. PULL-IN CONTROL VALVE
- 21. 3-2 CONTROL VALVE
- 22. N/D ENGAGEMENT CONTROL VALVE
- 23. 2-3 SERVO REGULATOR VALVE

Copyright © 2002 ATSG

Figure 74

AUTOMATIC TRANSMISSION SERVICE GROUP



FORD AXODE

3-NEUTRAL KICKDOWN SHIFT

COMPLAINT: A delayed shift may occur during 3-2 forced downshifts, or "Kickdown", and/or the transaxle will shift to neutral during the 3-2 kickdown.

CAUSE: The cause may be, a broken spring retainer clip between the pull-in control valve spring and the 3-2 control valve spring, as shown in Figure 75.

CORRECTION: Replace the spring retainer clip with OEM part number F1DZ-7F194-A, as shown in Figure 75.

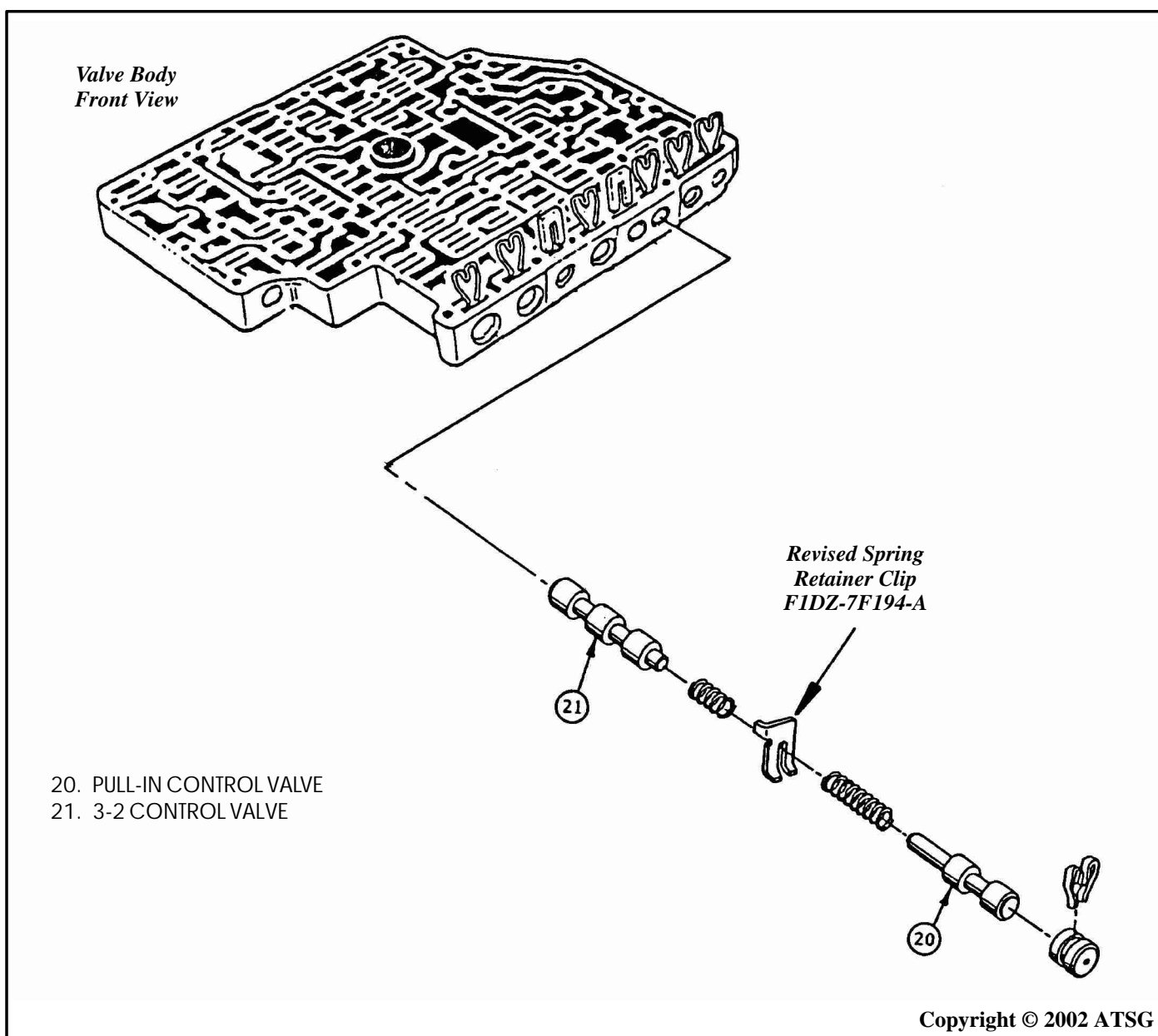

Figure 75



**AXODE (AX4S)
 PUMP AND VALVE BODY SPACER PLATE IDENTIFICATION**

AX4S BONDED PUMP SPACER PLATES

<i>OEM Part Number</i>	<i>Code</i>	<i>Application</i>	<i>Model Year</i>	<i>Engine</i>
F5DZ-7R167-A	AH	<i>Lincoln Continental</i>	1994	3.8L
		<i>Ford Taurus/Sable and Windstar</i>	1994-1995	ALL
F58Z-7R167-A	51	<i>Ford Windstar</i>	1995-1998	3.0L
		<i>Ford Windstar, Ford Taurus/Sable</i>	1996-1998	3.8L
X2FZ-7R167-AA	99	<i>Ford Windstar, Ford Taurus/Sable</i>	1999-2002	3.0L/3.8L

AX4S BONDED VALVE BODY SPACER PLATES

<i>OEM Part Number</i>	<i>Code</i>	<i>Application</i>	<i>Model Year</i>	<i>Engine</i>
F5DZ-7Z490-B	31	<i>Ford Taurus SHO</i>	1994-1995	3.2L
F5DZ-7Z490-C	40	<i>Ford Taurus/Sable</i>	1994-1995	3.0L
F5DZ-7Z490-D	41	<i>Lincoln Continental</i>	1994	3.8L
		<i>Ford Taurus/Sable</i>	1994-1995	3.8L
F58Z-7Z490-A	58	<i>Ford Windstar</i>	1995	3.8L
F58Z-7Z490-B	53	<i>Ford Windstar</i>	1995	3.0L
F6DZ-7Z490-FB	42(97)*	<i>Ford Taurus/Sable</i>	1996-1998	3.0L
F68Z-7Z490-A	47(67)*	<i>Ford Windstar</i>	1996-1997	3.8L
F88Z-7Z490-AA	98	<i>Ford Windstar</i>	1998	3.0L/3.8L
XF2Z-7Z490-AA	99	<i>Ford Taurus/Sable</i>	1999	3.0L
XF2Z-7Z490-AA	99	<i>Ford Windstar (W/VB's XD29-AB/AC/BB)</i>	1999	3.0L/3.8L
YF1Z-7Z490-AA	00	<i>Ford Taurus/Sable</i>	2000-2002	3.0L

OEM Part Number F6DZ-7Z490-FB has a "42" code and replaces the "97" code, as the "97" code spacer plate is no longer available.

OEM Part Number F68Z-7Z490-A has a "47" code and replaces the "67" code, as the "67" code spacer plate is no longer available.

CAUTION: Part Numbers may change or supersede without notice.

Copyright © 2002 ATSG

Figure 76



AXODE (AX4S) PUMP GASKETS

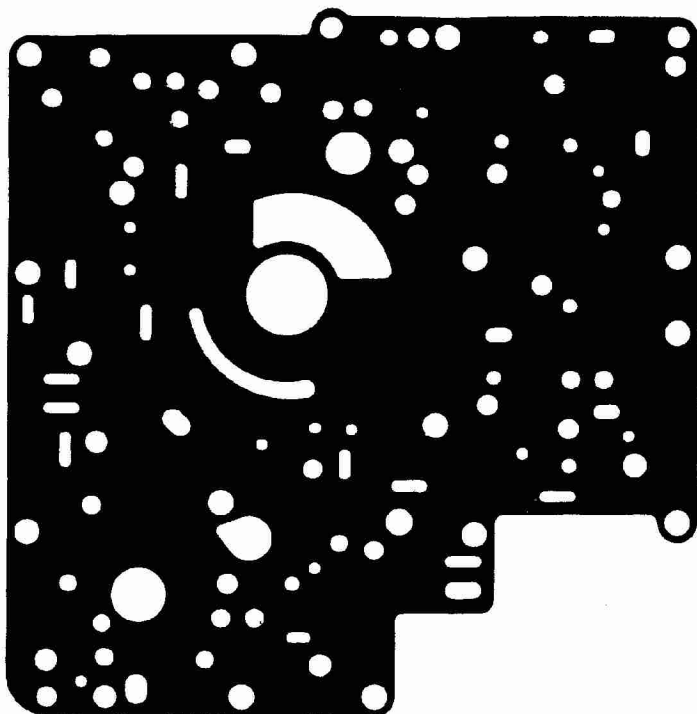

*1991-Up Pump Spacer
Plate To Valve Body
F1DZ-7A136-A
(Green I.D. Stripe)*

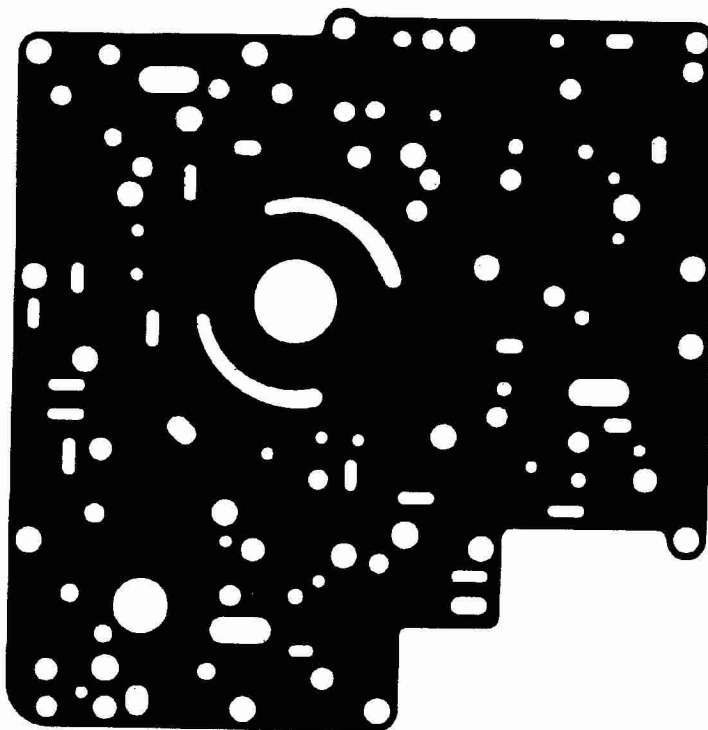

*1991-Up Pump Spacer
Plate To Pump Body
F3DZ-7G331-A
(Green I.D. Stripe)*

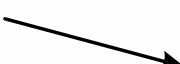

SPECIAL NOTE:
*Color Of The I.D. Stripe May
Vary From Different Suppliers*

Copyright © 2002 ATSG

Figure 77



AXODE (AX4S) 1991-1998
V.B. GASKETS

*1991-1998 Valve Body Spacer
Plate To Chain Cover
FIDZ-7C155-A
(Orange I.D. Stripe)*

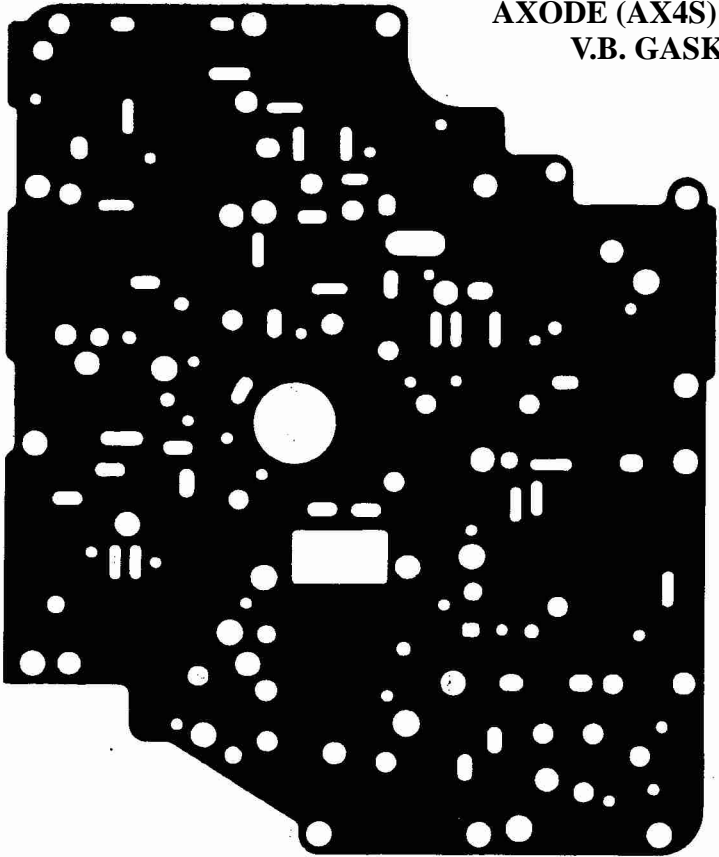

*1991-1998 Valve Body Spacer
Plate To Valve Body
FIDZ-7D100-A
(Orange I.D. Stripe)*

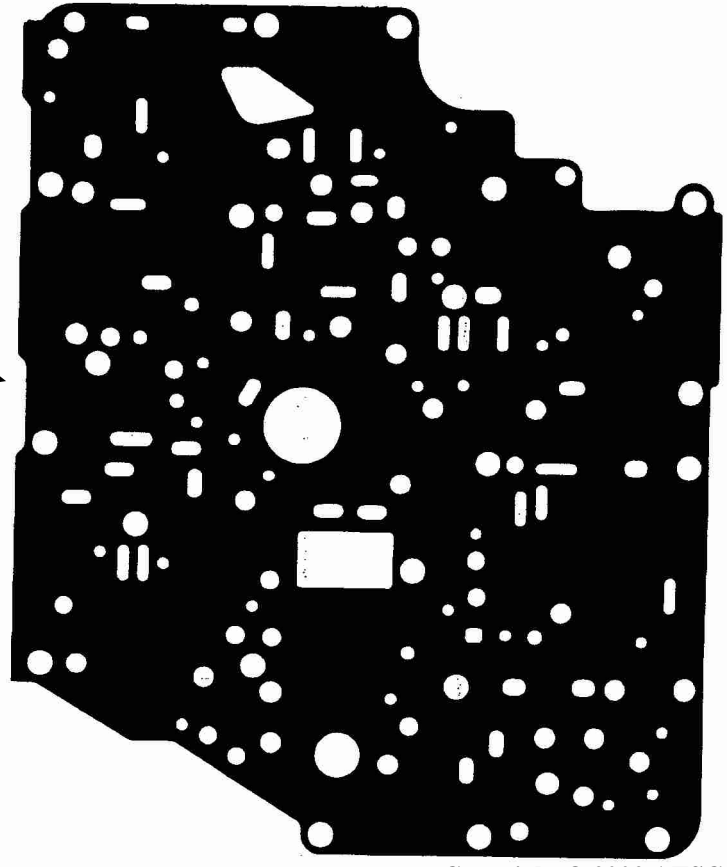

SPECIAL NOTE:
*Color Of The I.D. Stripe May
Vary From Different Suppliers*

Copyright © 2002 ATSG

Figure 78



**AXODE (AX4S) 1999-2002
V.B. GASKETS**

*1999-2002 Valve Body Spacer
Plate To Chain Cover
XF2Z-7C155-AA
(Yellow I.D. Stripe)*

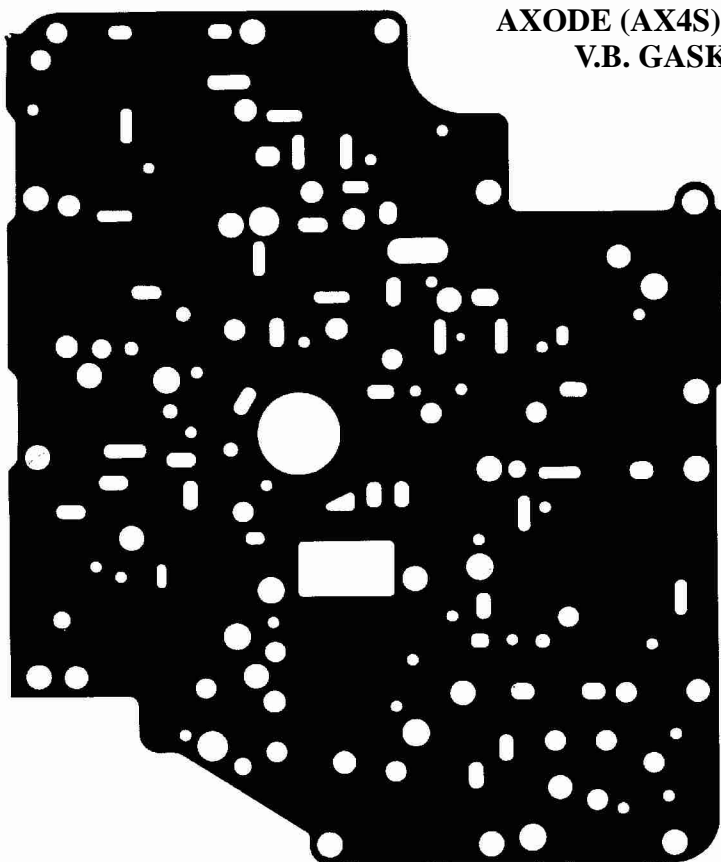

*1999-2002 Valve Body Spacer
Plate To Valve Body
XF2Z-7D100-AA
(Blue I.D. Stripe)*

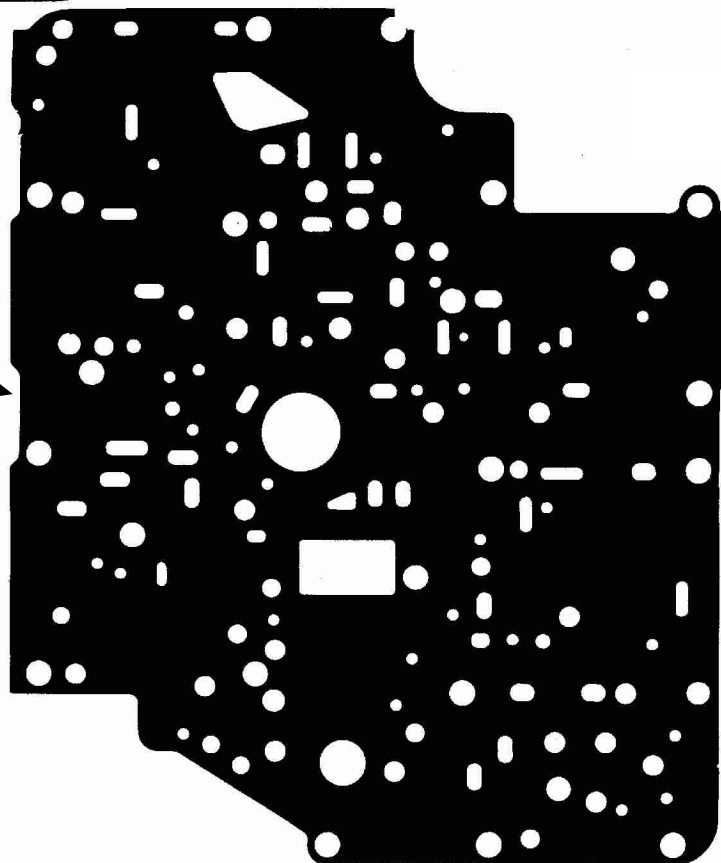

SPECIAL NOTE:
*Color Of The I.D. Stripe May
Vary From Different Suppliers*

Copyright © 2002 ATSG

Figure 79



Technical Service Information

**AXODE (AX4S) 1991-1992 ONLY
CHECKBALL AND RELIEF VALVE LOCATIONS**

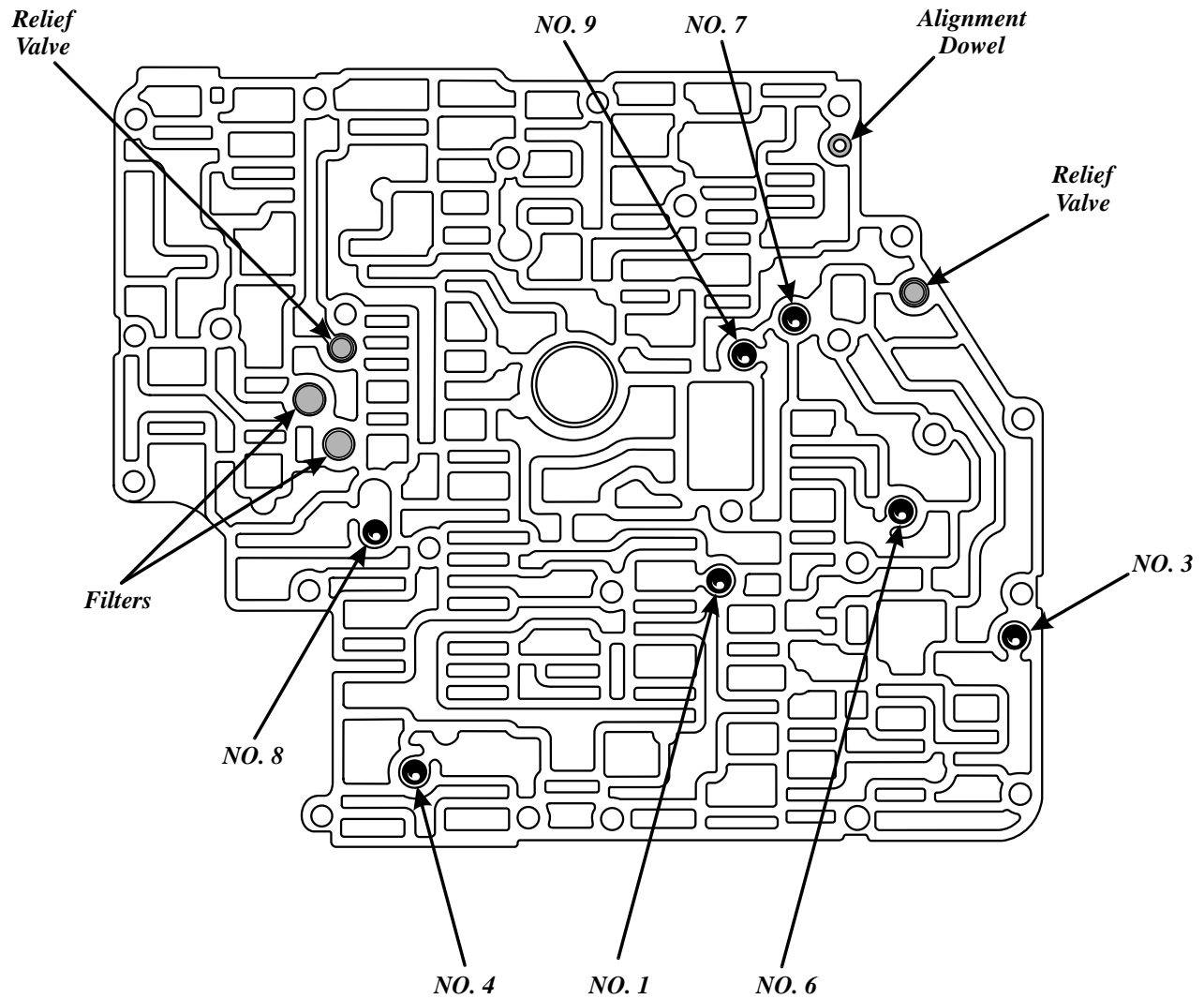

Copyright © 2002 ATSG

Figure 80



**AXODE (AX4S) 1993-1998
CHECKBALL AND RELIEF VALVE LOCATIONS**

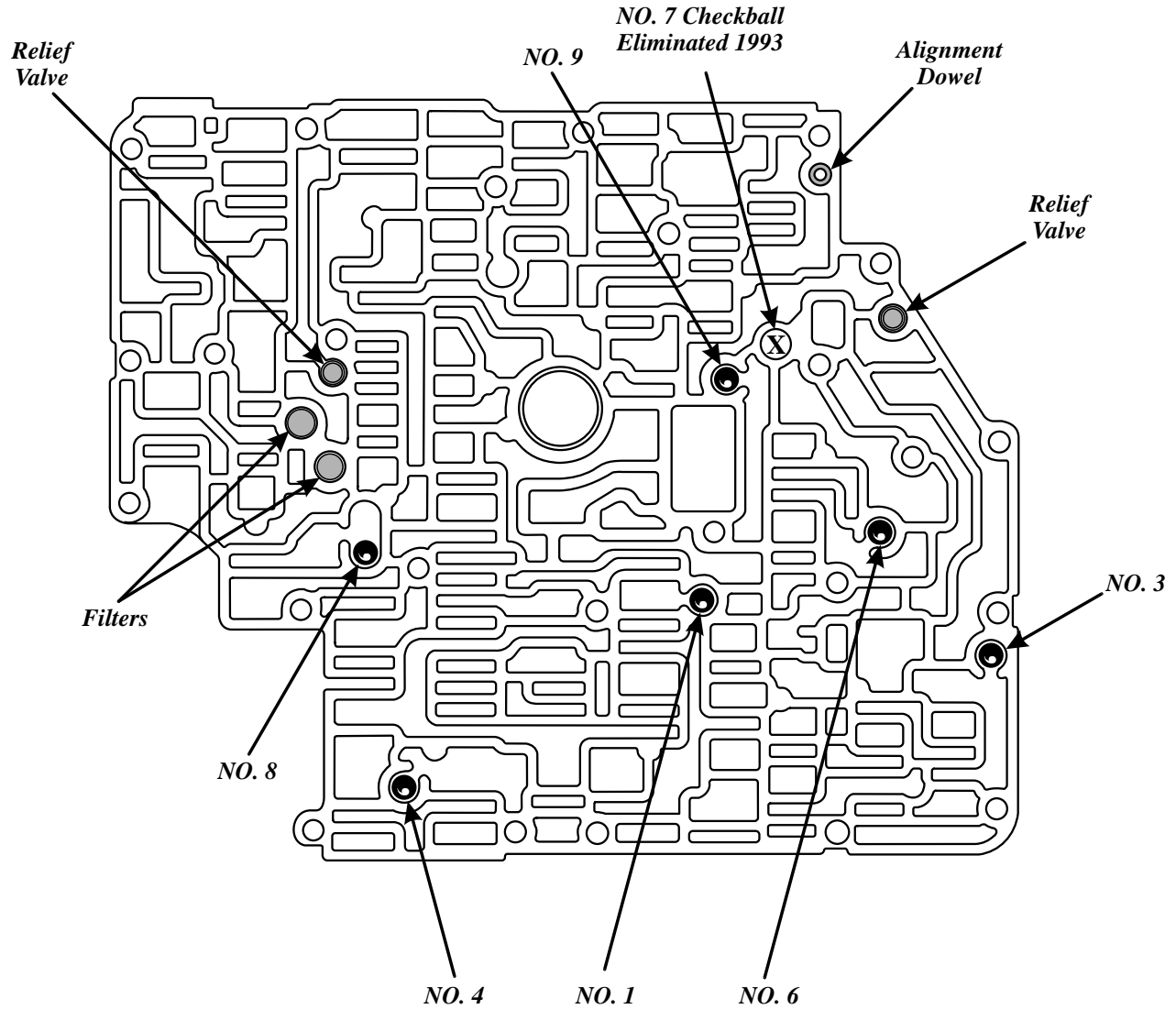

Copyright © 2002 ATSG

Figure 81

AUTOMATIC TRANSMISSION SERVICE GROUP



**AXODE (AX4S) 1999-2002
CHECKBALL AND RELIEF VALVE LOCATIONS**

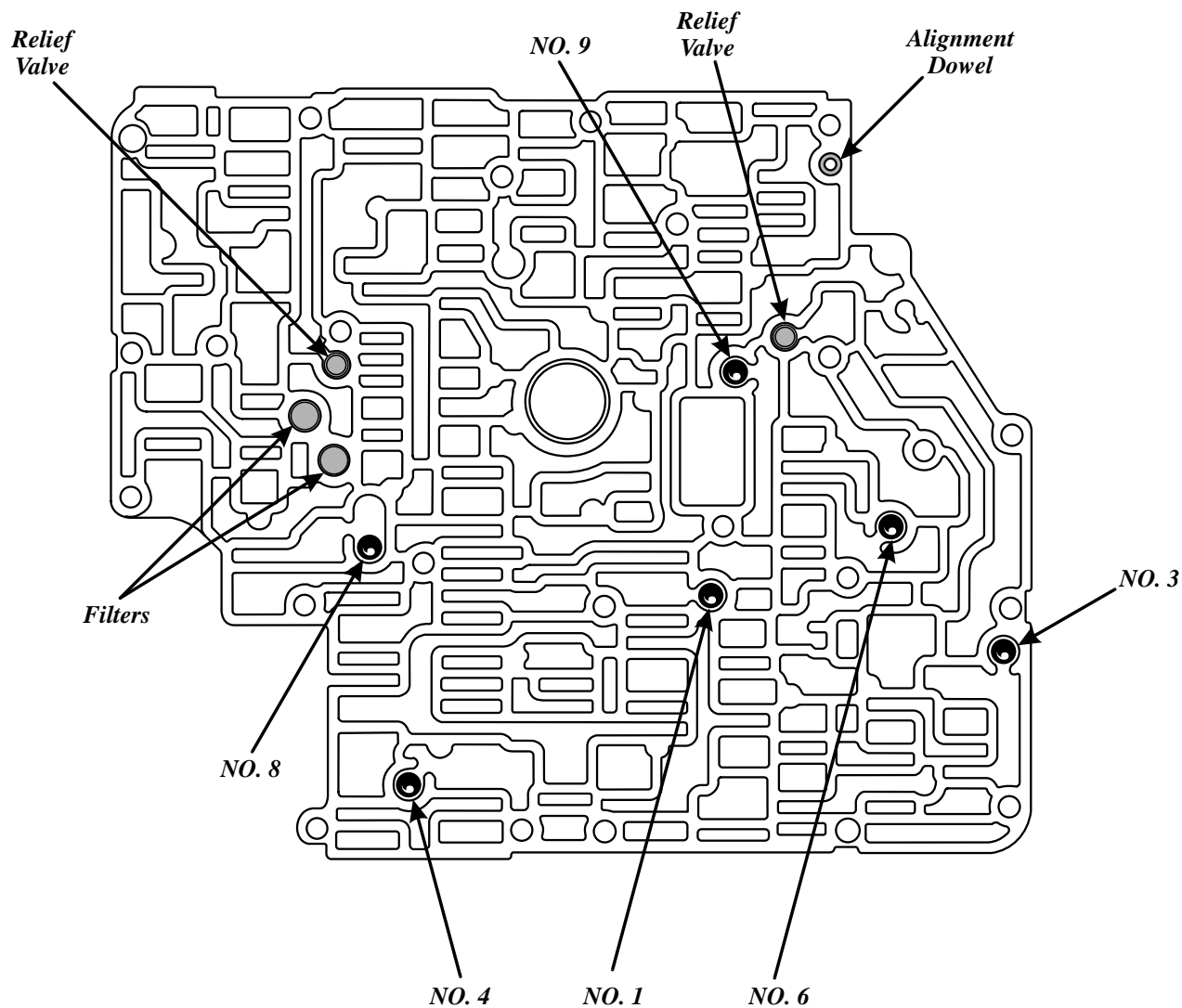

Copyright © 2002 ATSG

Figure 82



AXODE (AX4S) PREMATURE PLANETARY FAILURE

COMPLAINT: Front planetary and gear train failure with no visible root cause.

CAUSE: The cause may be, a limited volume of lube oil to the front planetary due to hydraulic control system demands.

CORRECTION: Install a new design "Cross-over" rear lube tube and a new design Differential/Speedo lube tube, that will increase the volume of lube oil to the front planetary system, as shown in Figure 83. This requires the rear lube tube to "Cross-over" the differential and speedo lube tube, as shown in Figure 83.

This change was implemented in mid-year 1992 for all AXODE transaxles.

SERVICE INFORMATION:

Crossover Rear Lube Tube	F2DZ-7G084-A
Differential/Speedo Lube Tube	F2DZ-7G086-A

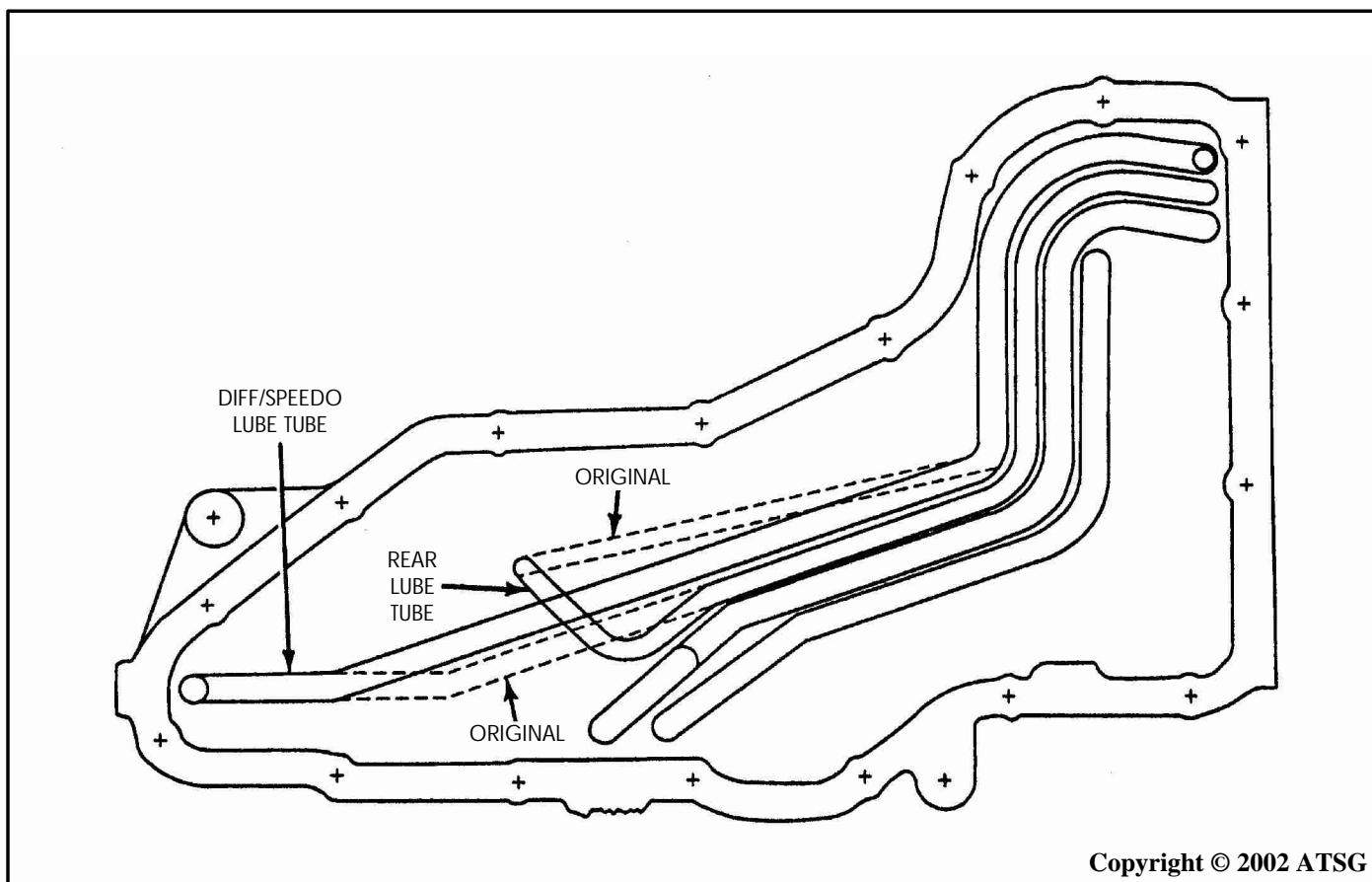

Figure 83



Technical Service Information

FORD AXODE (AX4S)

CHANGES FOR THE CHAIN COVER AND NO. 1 AND NO. 3 THRUST WASHERS

CHANGE: Beginning on October 13, 1995, introduced as a running change for 1996 models, the AX4S transaxles were built with new design Number 1 and Number 3 thrust washers (See Figure 84).

REASON: To improve the assembly process.

PARTS AFFECTED:

- (1) NUMBER 1 THRUST WASHER - New design washer has symmetrically located tabs for ease of assembly, as opposed to the previous design with non-symmetrically located tabs. Refer to Figure 84 for illustrations of both designs.
- (2) NUMBER 3 THRUST WASHER - New design washer is Black plastic with 3 symmetrically located tabs, as opposed to previous design bronze washer with tangs on the outside diameter. Refer to Figure 84 for illustrations of both designs.
- (3) CHAIN COVER - New design will accept either the previous bronze No. 3 thrust washer with the tangs on outside diameter, or the new design Black plastic No. 3 thrust washer with the 3 symmetrically located tabs, as shown in Figure 86.
The previous design Chain Cover will accept *only* the bronze No. 3 thrust washer with the tangs on the outside diameter, as shown in Figure 85.
The new design Chain Cover will accept *only* the new design No. 1 thrust washer with 3 symmetrically located tabs, as shown in Figure 86.
The previous design Chain Cover will accept *only* the previous design No. 1 thrust washer with 3 non-symmetrically located tabs, as shown in Figure 85.

INTERCHANGEABILITY:

If replacement of the number 1 and/or the number 3 thrust washer becomes necessary, inspect the chain cover in the thrust washer tab areas to determine the correct thrust washers required. Refer to Figures 85 and 86.

SERVICE INFORMATION:

Number 1 Thrust Washer (Before 10/13/95)	E6DZ-7G099-A
Number 3 Thrust Washer (Before 10/13/95)	E6DZ-7G096-A
Number 1 Thrust Washer (On or After 10/13/95)	F5DZ-7G099-A
Number 3 Thrust Washer (On or After 10/13/95)	F5DZ-7G096-A



PREVIOUS DESIGN

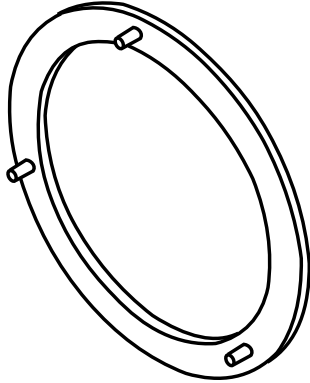

NUMBER 1 THRUST WASHER
WITH NON-SYMETRICALLY LOCATED TABS
PART NUMBER E6DZ-7G099-A

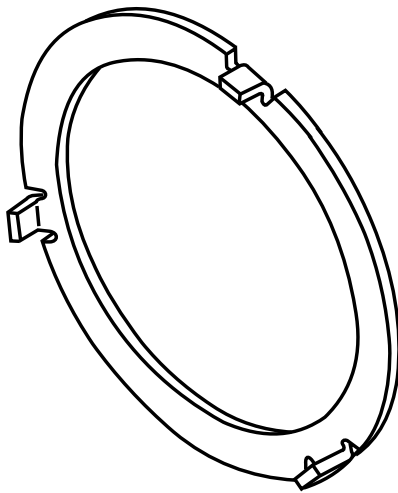

NUMBER 3 BRONZE THRUST WASHER
WITH TANGS ON OUTSIDE DIAMETER
PART NUMBER E6DZ-7G096-A

NEW DESIGN

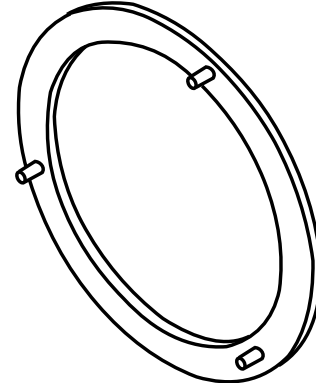

NUMBER 1 THRUST WASHER
WITH SYMETRICALLY LOCATED TABS
PART NUMBER F5DZ-7G099-A

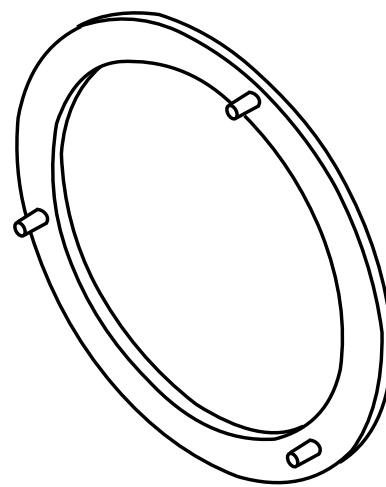

NUMBER 3 PLASTIC THRUST WASHER
WITH SYMETRICALLY LOCATED TABS
PART NUMBER F5DZ-7G096-A

Copyright © 2002 ATSG

Figure 84



**CHAIN COVER AND THRUST WASHERS
PRIOR TO OCTOBER 13, 1995**

**NUMBER 3
THRUST WASHER**

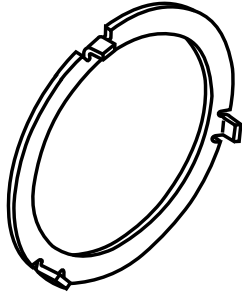

REQUIRES THE BRONZE NO. 3
THRUST WASHER WITH TANGS ON
THE OUTSIDE DIAMETER
PART NUMBER E6DZ-7G096-A

**NUMBER 1
THRUST WASHER**

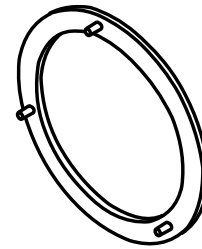

REQUIRES THE PLASTIC NO. 1
THRUST WASHER WITH TABS THAT
ARE NON-SYMETRICALLY LOCATED
PART NUMBER E6DZ-7G099-A

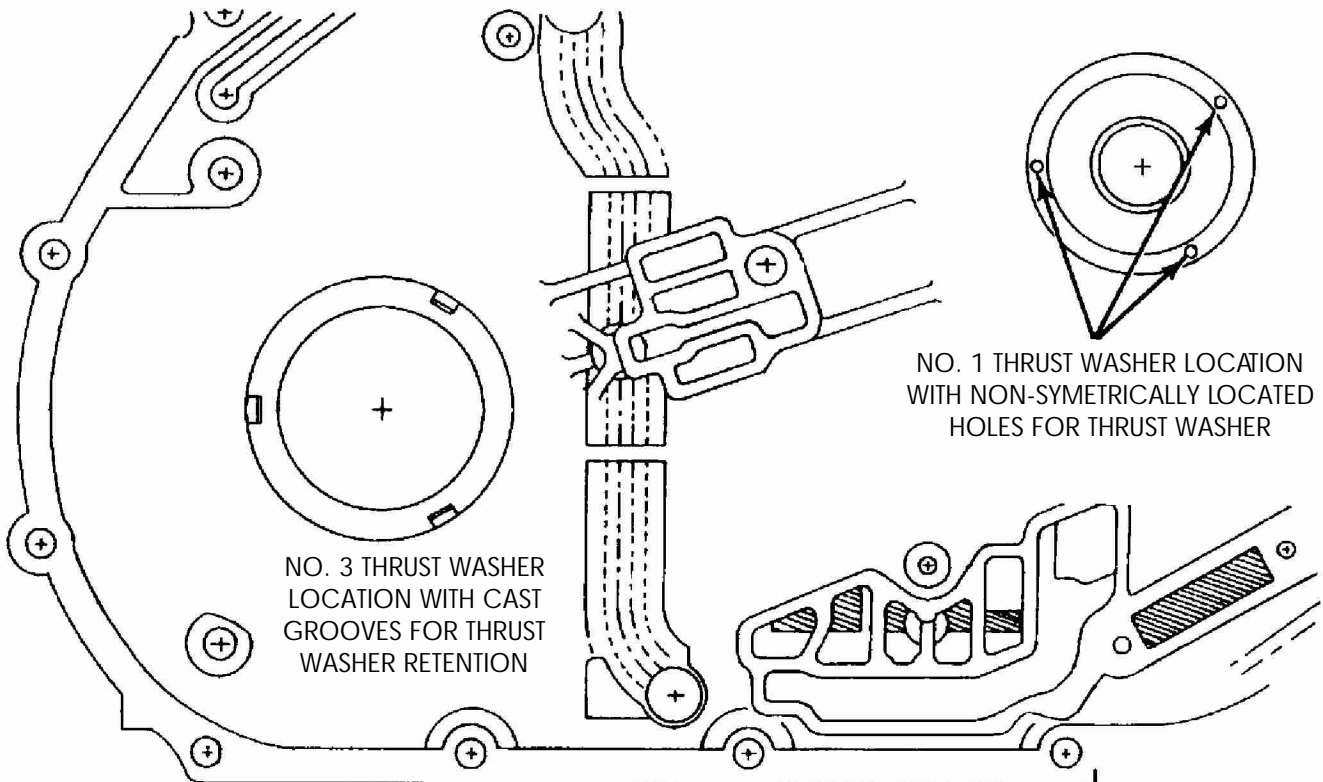

NO. 3 THRUST WASHER
LOCATION WITH CAST
GROOVES FOR THRUST
WASHER RETENTION

NO. 1 THRUST WASHER LOCATION
WITH NON-SYMETRICALLY LOCATED
HOLES FOR THRUST WASHER

Copyright © 2002 ATSG

Figure 85



**CHAIN COVER AND THRUST WASHERS
OCTOBER 13, 1995 AND BEYOND**

**NUMBER 3
THRUST WASHER**

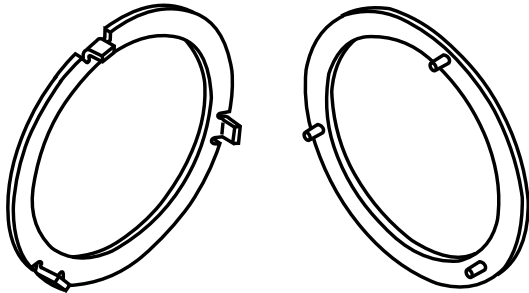

(BRONZE)
E6DZ-7G096-A

(BLACK PLASTIC)
F5DZ-7G096-A

CAN USE EITHER OF THE
PART NUMBERS LISTED ABOVE

**NUMBER 1
THRUST WASHER**

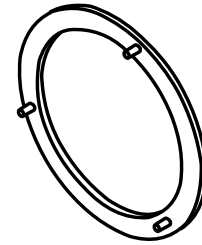

REQUIRES THE PLASTIC NO. 1
THRUST WASHER WITH TABS THAT
ARE SYMETRICALLY LOCATED
PART NUMBER F5DZ-7G099-A

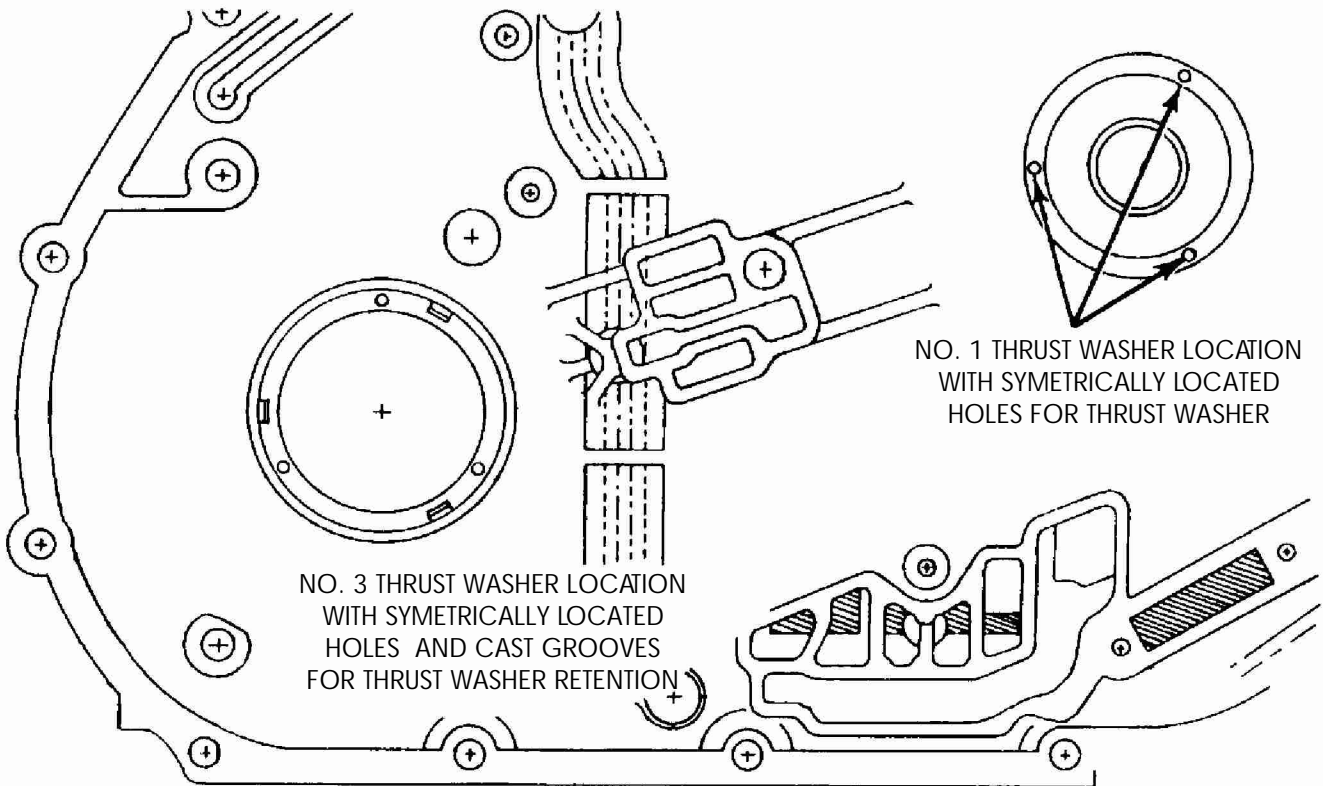

NO. 3 THRUST WASHER LOCATION
WITH SYMETRICALLY LOCATED
HOLES AND CAST GROOVES
FOR THRUST WASHER RETENTION

NO. 1 THRUST WASHER LOCATION
WITH SYMETRICALLY LOCATED
HOLES FOR THRUST WASHER

Copyright © 2002 ATSG

Figure 86



Technical Service Information

FORD AXOD-E (1991-1992 ONLY)

ELECTRICAL DIAGNOSIS (UPDATED)

EPC SOLENOID:

Wires for the Electronic Pressure Control solenoid are fed through pins 1 and 6 of the "Black/Gray" case connector, located on top of the transaxle (See Figure 88). Ohmmeter across terminals 1 and 6 should read 2.5-6.5 Ohms resistance.

CAUTION! — POPPED A COMPUTER LATELY? — CAUTION!

MODULATED LOCK-UP SOLENOID (MLUS):

Wires for the Modulated Lock-Up Solenoid (MLUS) are fed through pins 4 and 5 of the "Gray" case connector, located on top of the transaxle (See Figure 88). Ohmmeter across terminals 4 and 5 should read 0.75-2.0 Ohms resistance if you have MLUS. The Modulated Lock-Up Solenoid (MLUS) is found on the *Lincoln Only* for the 1991 model year. Taurus/Sable for 1991 are the regular Lock-Up Solenoid (LUS) that is described below. *All models for 1992 model year are MLUS.*

LOCK-UP SOLENOID (LUS):

Wires for the Lock-Up Solenoid (LUS) are fed through pins 4 and 5 of the "Black" case connector, located on top of the transaxle (See Figure 88). Ohmmeter across terminals 4 and 5 should read 16-40 Ohms resistance if you have LUS. The Lock-Up Solenoid (LUS) is found on the *Taurus/Sable Only* for the 1991 model year. Lincoln for 1991 is the Modulated Lock-Up Solenoid (MLUS) that is described above. *All models for 1992 model year are MLUS.*

CAUTION! — CAUTION! — CAUTION! — CAUTION! — CAUTION!

TRANSAXLE OIL TEMPERATURE SENSOR (TOT):

Wires for the Transaxle Oil Temperature (TOT) sensor are fed through pins 2 and 3 of the "Black/Gray" case connector, located on top of the transaxle (See Figure 88). Ohmmeter across terminals 2 and 3 should read the approximate resistance listed in the chart below. Resistance should decrease if transaxle is heated, and should increase if transaxle is allowed to cool. Oil pan that is warm to the touch is about 105°F-158°F.

°C	°F	TOT SENSOR (OHMS)
0-20	32-58	100k - 37k
21-40	59-104	37k - 16k
41-70	105-158	16k - 5k
71-90	159-194	5k - 2.7k
91-110	195-230	2.7k - 1.5k
111-130	231-266	1.5k - 0.8k
131-150	267-302	0.8k - 0.5k

Copyright © 2002 ATSG



SHIFT SOLENOID 1:

Wires for Shift Solenoid 1 are fed through pins 5 and 6 of the "White" case connector, located on the side of transaxle (See Figure 88). Ohmmeter across terminals 5 and 6 should read 12-30 Ohms resistance.

SHIFT SOLENOID 2:

Wires for Shift Solenoid 2 are fed through pins 1 and 2 of the "White" case connector, located on the side of transaxle (See Figure 88). Ohmmeter across terminals 1 and 2 should read 12-30 Ohms resistance.

SHIFT SOLENOID 3:

Wires for Shift Solenoid 3 are fed through pins 3 and 4 of the "White" case connector, located on the side of transaxle (See Figure 88). Ohmmeter across terminals 3 and 4 should read 12-30 Ohms resistance.

TURBINE SPEED SENSOR:

The Turbine Speed Sensor is located on the channel plate next to the left hand axle seal. With Ohmmeter across the two terminals of the TSS, there should be 100-200 Ohms resistance.

MANUAL LEVER POSITION SENSOR (MLPS):

The Manual Lever Position Sensor is checked across pins 2 and 3 of the sensor as shown in illustration below. With Ohmmeter across pins 2 and 3 the resistance reading should correspond to the chart below.

<i>Lever Position</i>	<i>Ohms Resistance</i>
<i>P</i> -----	<i>3769-4608</i>
<i>R</i> -----	<i>1303-1594</i>
<i>N</i> -----	<i>660-807</i>
<i>D</i> -----	<i>361-442</i>
<i>2</i> -----	<i>190-232</i>
<i>1</i> -----	<i>80-95</i>

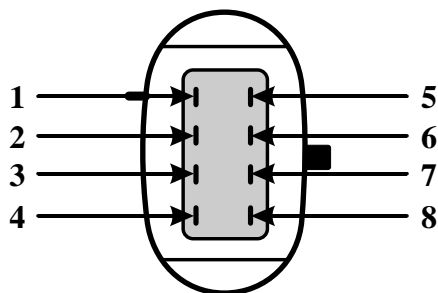

(View Looking Into MLPS)

Copyright © 2002 ATSG

Figure 87



1991-1992 AXOD-E INTERNAL WIRE SCHEMATIC

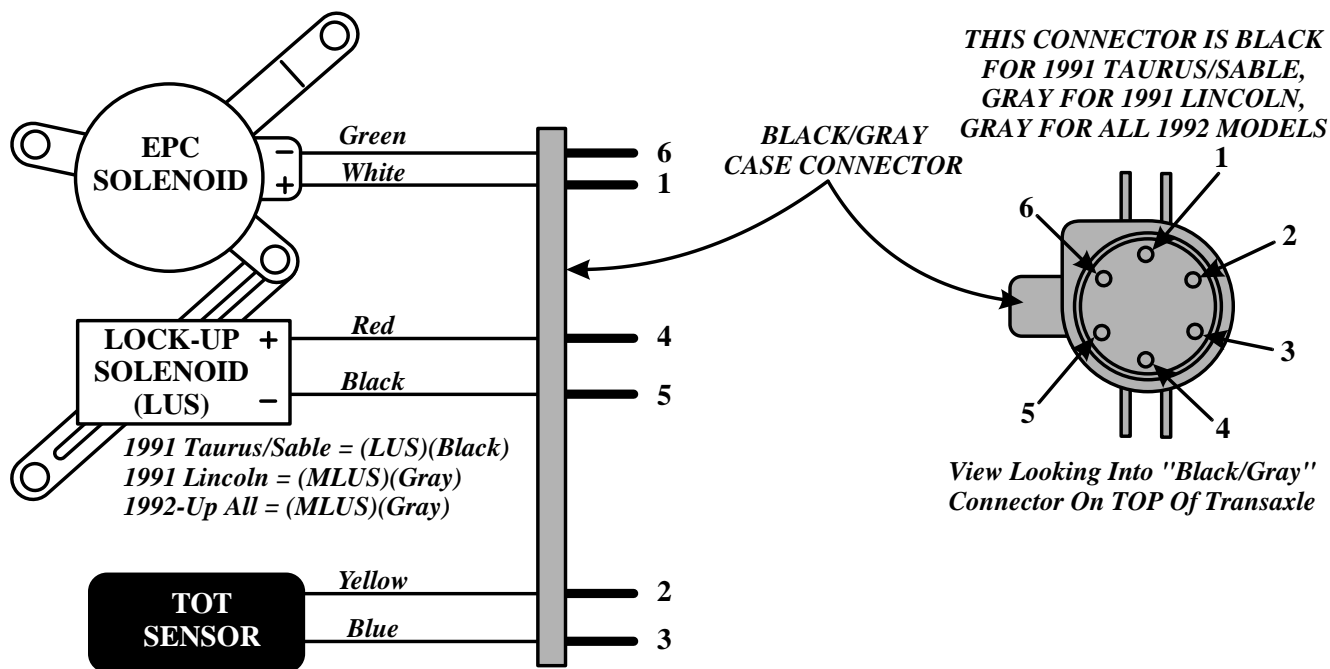

The 1991-1992 AXOD-E transaxle has 2 case connectors, 1 Black or Gray in color on the top of the transaxle, and 1 White in color on the side of the transaxle.

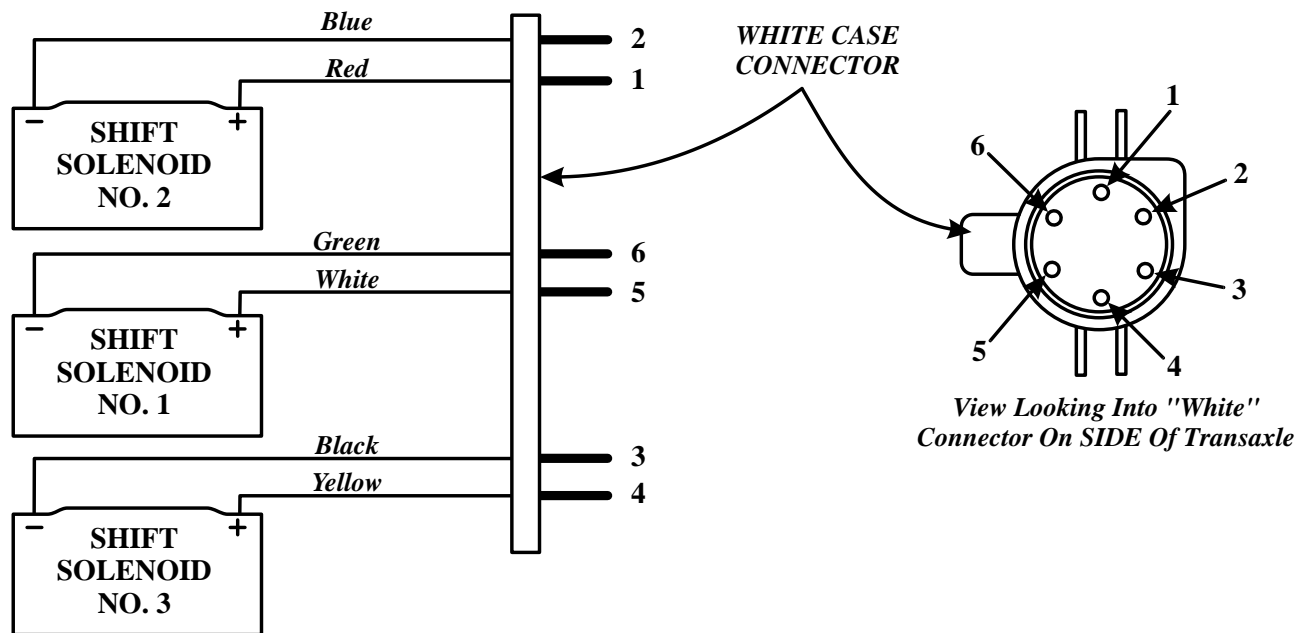

Copyright © 2002 ATSG

Figure 88



**FORD AXODE
NEW DESIGN CHAIN COVER KIT
FOR 1991-1992 MODELS**

If service requires replacement of the chain cover on a 1991 or 1992 AXODE transaxle, it must be replaced with a 1993 design level AXODE chain cover assembly kit. The 1993-Up design level chain cover has only one nine pin external electrical connector located at the top of the transaxle as shown in Figure 89, and the previous side connector, as shown in Figure 88, has been eliminated. This requires a new "Y" harness, which is included in the service package "Kit", to make it compatible with 91-92 vehicles. The new design "Y" harness is also illustrated in Figure 89.

- AXODE Chain Cover Assembly Kit F1DZ-7G188-B
- AXODE Jumper "Y" Harness F1DZ-7Z432-A

Note: Chain Cover Assembly "Kit" includes Chain Cover, New Internal Harness, New Jumper Harness, Eight Tie Wraps and Instruction Sheet.

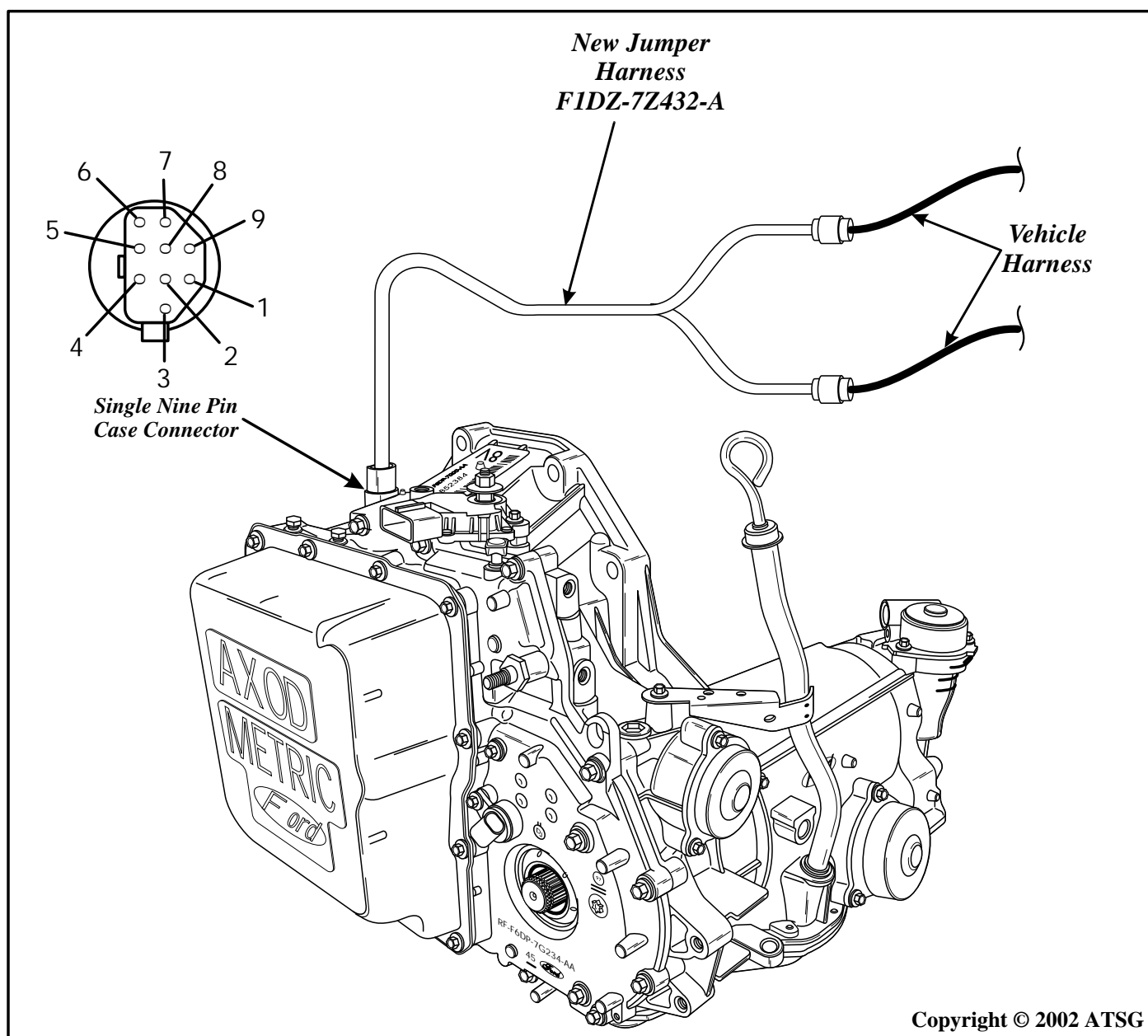

Copyright © 2002 ATSG

Figure 89



Technical Service Information

FORD AX4S/AXODE

HARSH SHIFTS, CLICKING NOISE, TIE-UP ON SHIFTS

1993-UP AFTER REBUILD

COMPLAINT: *After rebuild*, harsh shifts (High Line) and/or a "Clicking" or cycling noise may be heard from the side cover area, that is usually accompanied by an ON/OFF bind-up sensation that coincides with the "Clicking" noise. These symptoms may be accompanied with Diagnostic Trouble Code (DTC) 652 (MLUS Shorted or Open Circuit), DTC 624 (EPC Circuit Failure), and/or one Shift Solenoid DTC 621, 622, or 624.

CAUSE: The cause may be, solenoid wire connectors installed on the wrong solenoids.

CORRECTION: Connect the internal wiring harness connectors to their proper solenoids, *using the wire colors*, as shown in Figure 90 and 91. Proper connection of solenoids can also be verified externally through the case connector using the Ohms chart in Figure 91.

NOTE: The internal wire harness normally is secured by wire-ties which would prevent improper connection of solenoids, however, not all wire harnesses have the wire ties necessary to prevent this problem and the chart must be used.

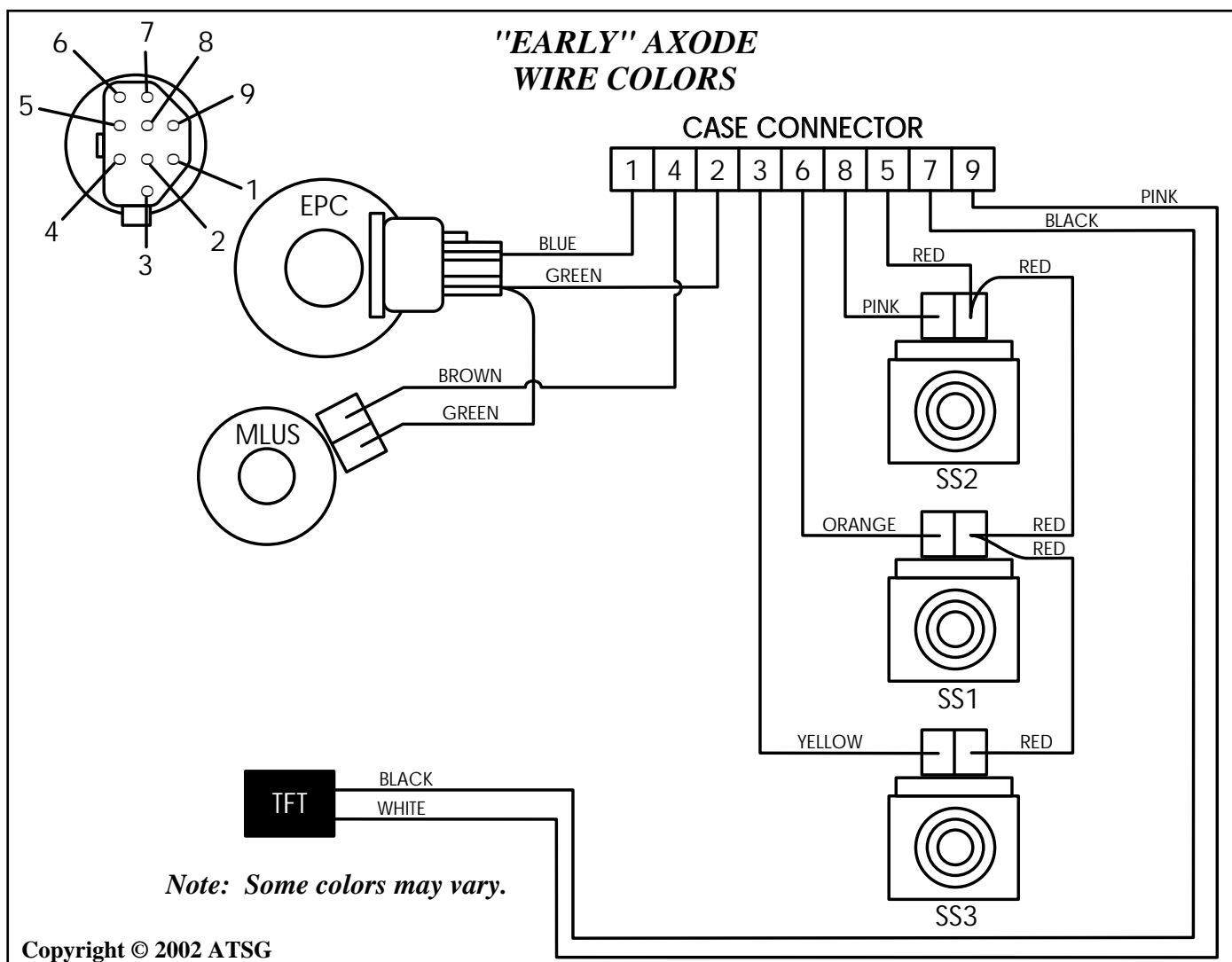

Figure 90



**SHIFT SOLENOID RESISTANCE CHART
AND TFT SENSOR RESISTANCE CHART
FOR AXODE (AX4S)**

SOLENOID	SOLENOID RESISTANCE (OHMS)	°C	°F	TFT SENSOR (OHMS)
SS1	15 - 25	0-20	32-58	100k - 37k
SS2	15 - 25	21-40	59-104	37k - 16k
SS3	15 - 25	41-70	105-158	16k - 5k
MLUS	.98 - 1.6	71-90	159-194	5k - 2.7k
EPC	3.23 - 5.50	91-110	195-230	2.7k - 1.5k
TSS	100 - 200	111-130	231-266	1.5k - 0.8k
VSS	190 - 250	131-150	267-302	0.8k - 0.5k

1. EPC GROUND (VIOLET)
2. EPC AND MLUS POWER (LT GREEN)
3. SS3 GROUND (YELLOW)
4. MLUS GROUND (BROWN)
5. SHIFT SOLENOID POWER (RED)
6. SS1 GROUND (ORANGE)
7. TFT (BLACK)
8. SS2 GROUND (PINK)
9. TFT RETURN (PINK)

**"LATE" AXODE
WIRE COLORS**

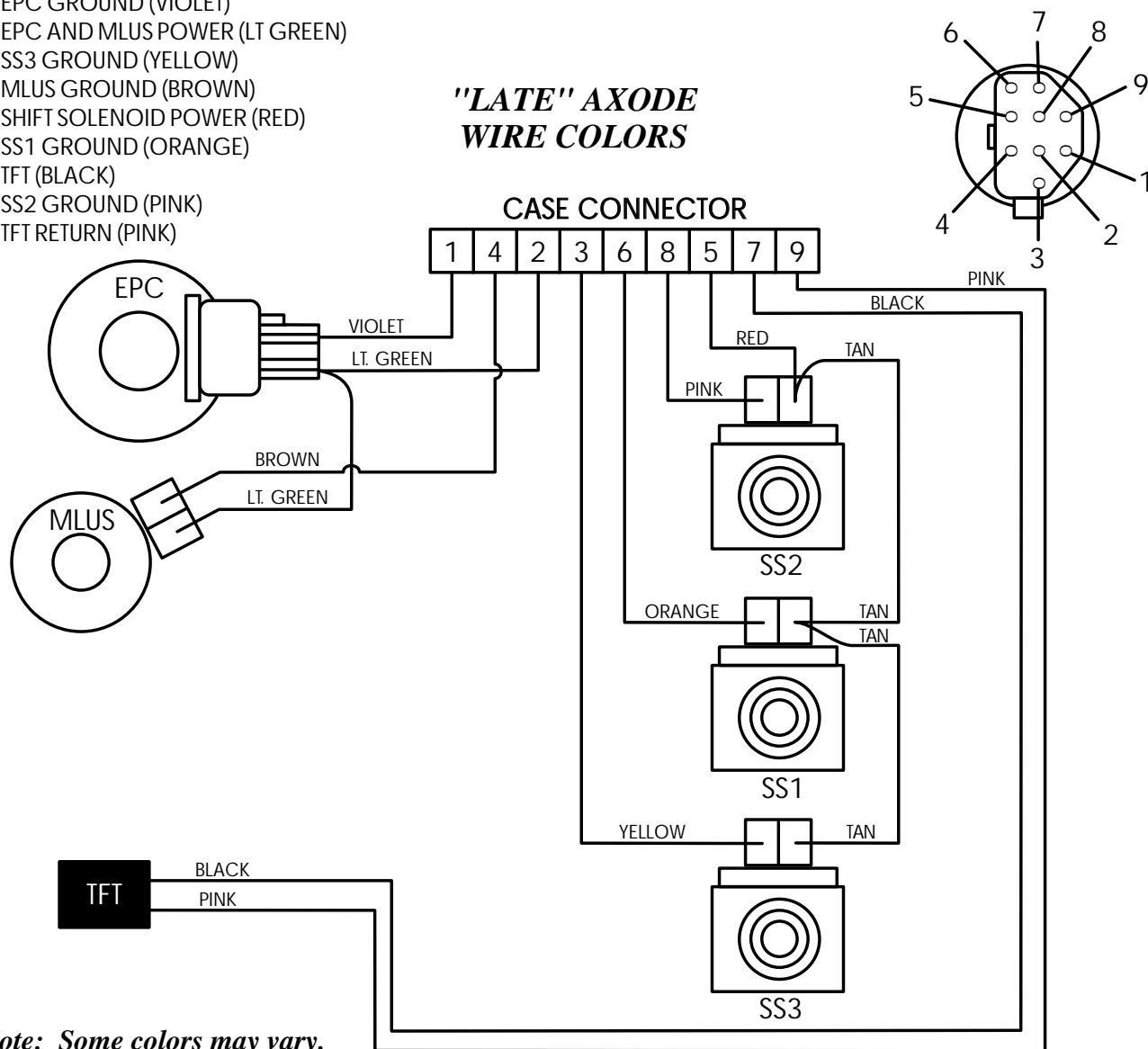

Note: Some colors may vary.

Copyright © 2002 ATSG

Figure 91

Technical Service Information



FORD AX4S/AX4N

**TCC SOLENOID CHANGE AND
SHIFT SOLENOID INTERCHANGE**

CHANGE: At the start of production for the 1997 model year, the Lincoln Continental equipped with the AX4N transaxle, received a new design and higher resistance, Modulated Lock-Up Solenoid. At the start of production for the 1998 model year, the Taurus and Sable equipped with the AX4S transaxle, also received this new design Modulated Lock-Up Solenoid (MLUS).

REASON: Much improved converter clutch application and durability.

PARTS AFFECTED:

MODULATED LOCK-UP SOLENOID - The new design MLUS is round, like the previous (1) design solenoid, but has a **blue** connector instead of the previous white, and a resistance value of **13-24 Ohms**, instead of the previous 0.98-1.6 Ohms resistance (See Figure 92).

INTERCHANGEABILITY:

The O.E. Manufacturer first advised not to interchange the solenoids, but has since backed off of that statement, as the only MLUS now available is the new design with the blue connector and higher resistance. ATSG has seen **no problems** with installing the new design MLUS on the previous model transaxles, **except** 1991 Taurus and Sable which are non-modulated models. Use the chart in Figure 93 to check the resistance of the MLUS through the case connector to determine which solenoid is in the transaxle.

SPECIAL NOTE:

Shift Solenoids - Shift Solenoids for the AX4S transaxle and AX4N transaxle are identical in every dimension and every respect **except** one. Shift Solenoids for the **AX4S have a diode** in the solenoid, and Shift Solenoids for the **AX4N do not have a diode** in the solenoid, as the vehicles equipped with the AX4N have the diodes in the processor.

This means that the AX4S Shift Solenoids **can be used** in AX4N transaxles, but AX4N Shift Solenoids **cannot be used** in AX4S transaxles, as there would be no diode protection.

Most suppliers stock only the AX4S shift solenoid, as it works well on both.

SERVICE INFORMATION:

Modulated TCC Solenoid with Blue Connector.....	F7OZ-7G136-AA
Modulated TCC Solenoid with White Connector.....	F3DZ-7G136-AA
AX4S Transaxle Shift Solenoids	F1DZ-7G484-A
AX4N Transaxle Shift Solenoids	F3DZ-7G484-AA

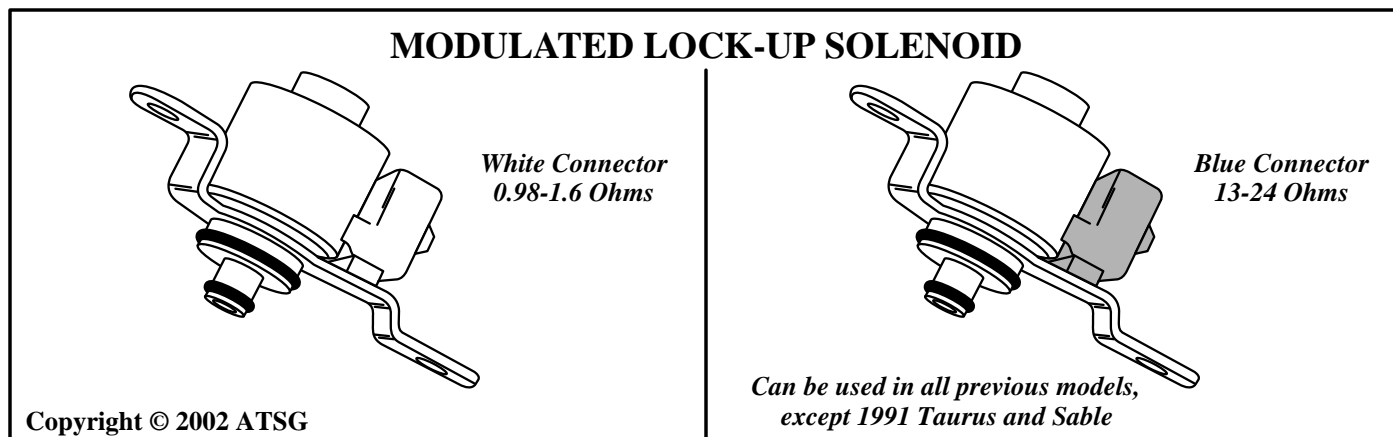

Figure 92



SOLENOID	SOLENOID RESISTANCE (OHMS)
SS1	15 - 25
SS2	15 - 25
SS3	15 - 25
EARLY MLUS	.98 - 1.6
LATE MLUS	13-24
EPC	3.23-5.50

°C	°F	TFT SENSOR (OHMS)
0-20	32-58	100k - 37k
21-40	59-104	37k - 16k
41-70	105-158	16k - 5k
71-90	159-194	5k - 2.7k
91-110	195-230	2.7k - 1.5k
111-130	231-266	1.5k - 0.8k
131-150	267-302	0.8k - 0.5k

1. EPC GROUND
2. EPC AND MLUS POWER
3. SS3 GROUND
4. MLUS GROUND
5. SHIFT SOLENOID POWER
6. SS1 GROUND
7. TFT
8. SS2 GROUND
9. TFT RETURN

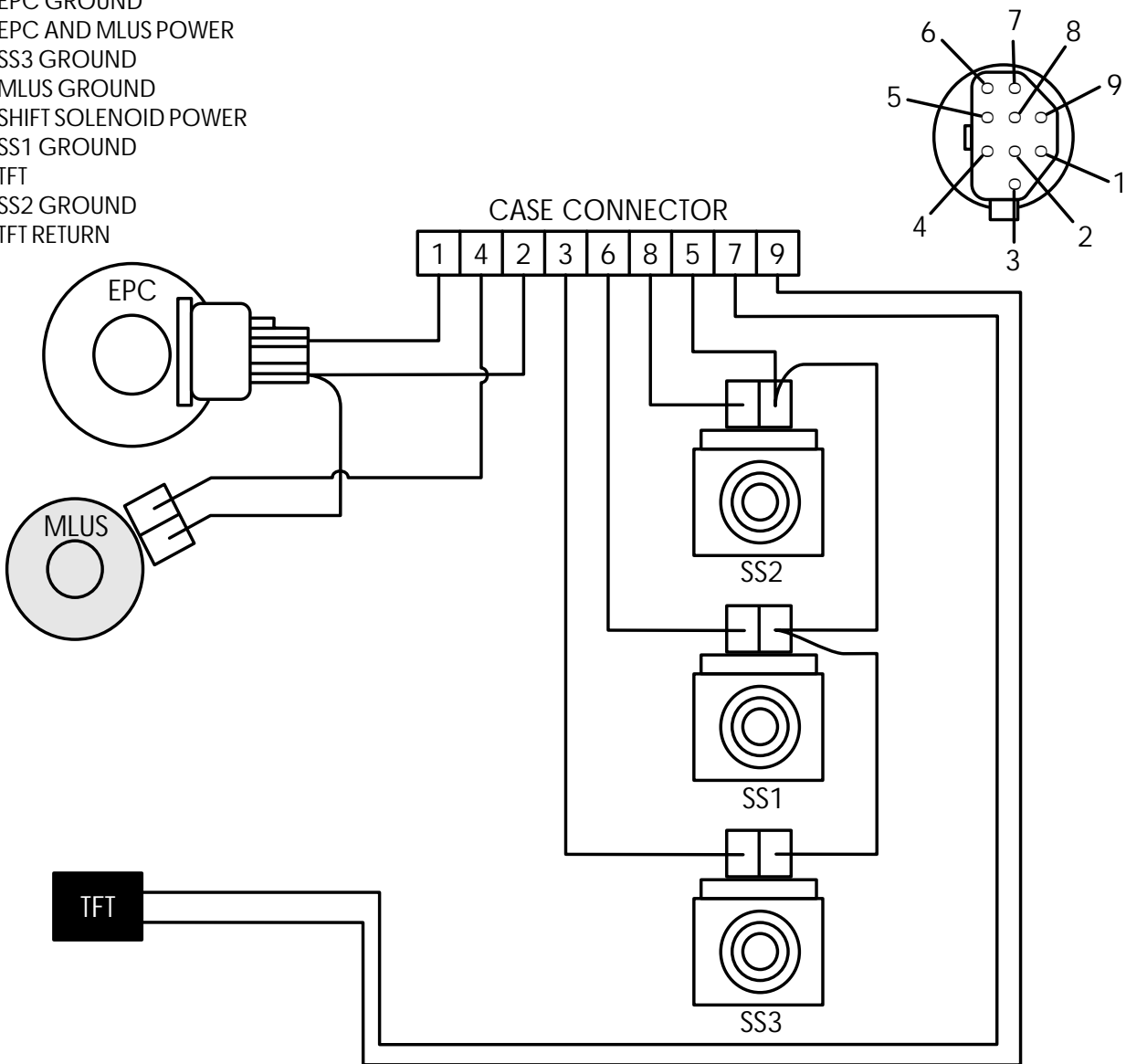

Copyright © 2002 ATSG

Figure 93

AUTOMATIC TRANSMISSION SERVICE GROUP



Technical Service Information

FORD AX4S/AX4N VEHICLE SPEED SENSOR CHANGES

CHANGE: The gear driven vehicle speed sensor that has been in use in the AX4S and the AX4N since their inception will be replaced, as a running change during the 1999 model year beginning with the AX4S, and at the start of production for the 2000 model year for the AX4N, with a permanent magnet speed sensor. The PM Generator will be mounted in the barrel of the case and will be using the park gear teeth as an exciter wheel.

REASON: The possibility of the VSS drive or driven gear "apple coring" will be eliminated as well as the intermittent loss of vehicle speed signal due to the speed sensor sub harness damage that would occur as a result of exhaust system heat transferral.

PARTS AFFECTED:

- (1) TRANSAXLE CASE - Changed to accommodate mounting the new design speed sensor so that it is in line with the planetary support and the park gear.
- (2) FINAL DRIVE SUPPORT - Changed to accommodate mounting the new design speed sensor and now has a "*cut out*" for the speed sensor to look through at the park gear, as shown in Figure 94.

INTERCHANGEABILITY:

The PM Generator type of speed sensor being new to the vehicle line, would prevent them from being used in any earlier vehicles not designed with this type of system.

The vehicle speed sensor for the AX4S is illustrated in Figure 95 and the vehicle speed sensor for the AX4N is shown in Figure 96.

SERVICE INFORMATION:

AX4S Vehicle Speed Sensor.....	XF2Z-7H103-AA
AX4N Vehicle Speed Sensor.....	YF1Z-7H103-AA

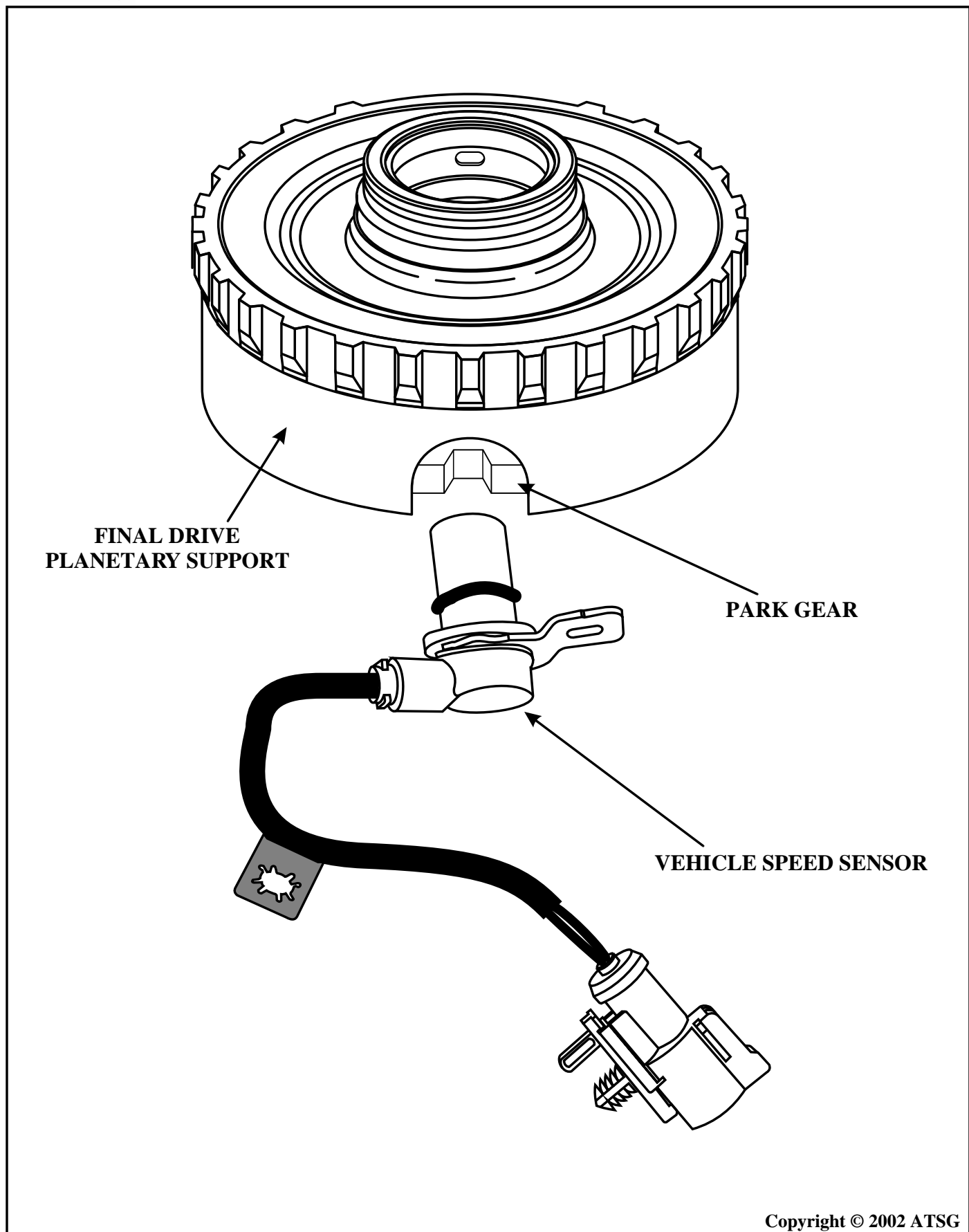

Copyright © 2002 ATSG

Figure 94

AUTOMATIC TRANSMISSION SERVICE GROUP



AX4S VEHICLE SPEED SENSOR

PART NUMBER XF2Z-7H103-AA

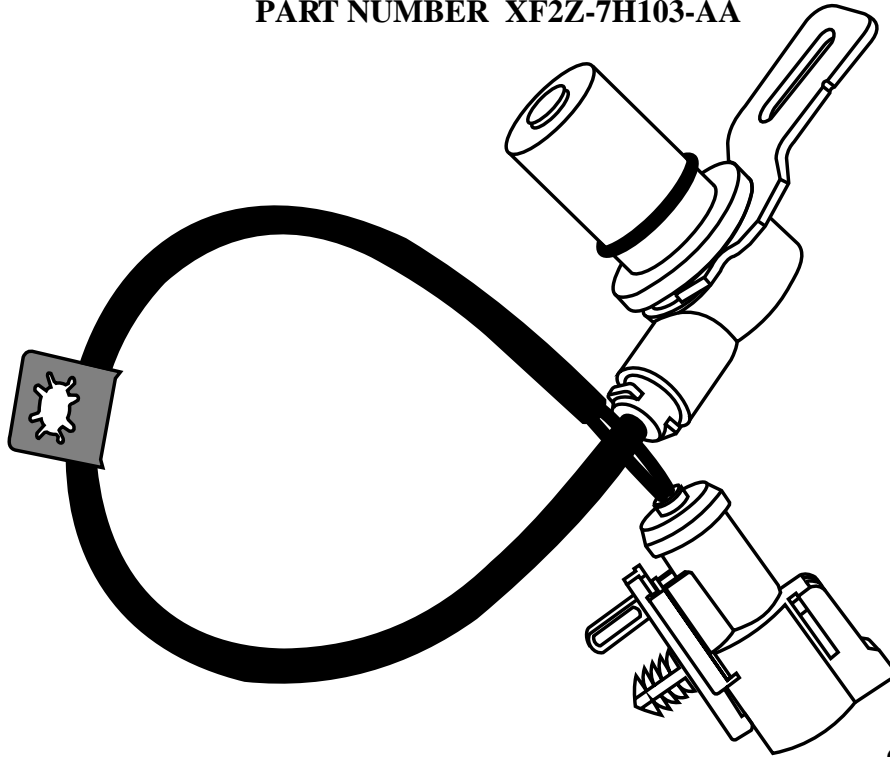

Copyright © 2000 ATSG

Figure 95

AX4N VEHICLE SPEED SENSOR

PART NUMBER YF1Z-7H103-AA

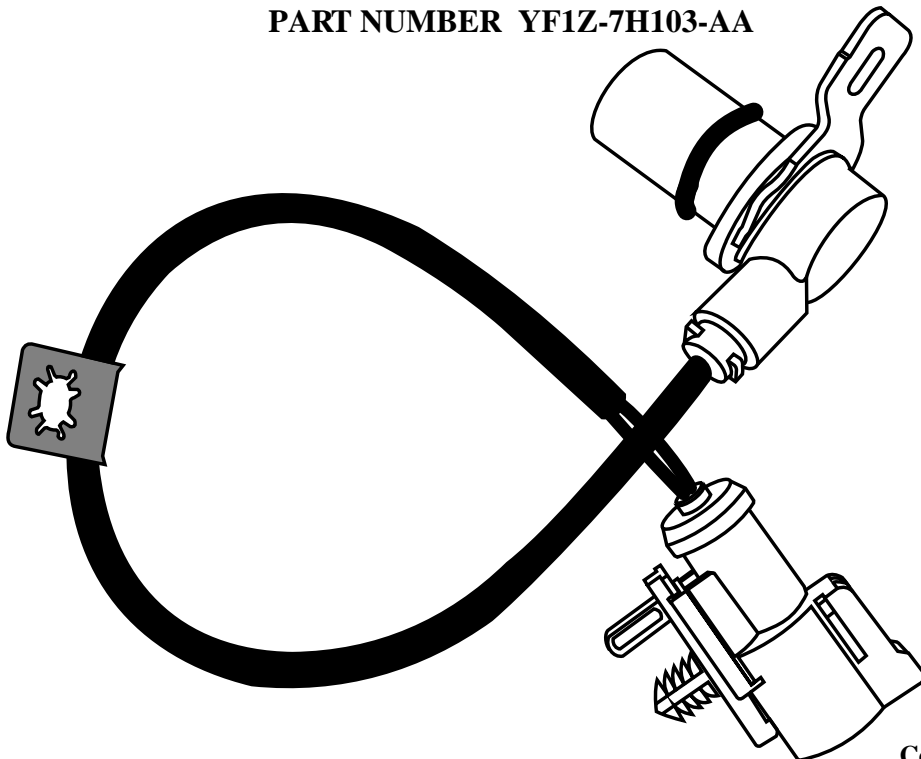

Copyright © 2002 ATSG

Figure 96



FORD AX4S (AXOD-E) AND AX4N PRESSURE TAP LOCATIONS

Most technical manuals, including Ford Motor Company manuals, have the pressure tap locations identified wrong. Use this page to correct your manuals at the shop for the correct pressure tap locations.

Refer to Figure 97 for the AX4S (AXOD-E) transaxle pressure tap locations.

Refer to Figure 97 for the AX4N transaxle pressure tap locations.

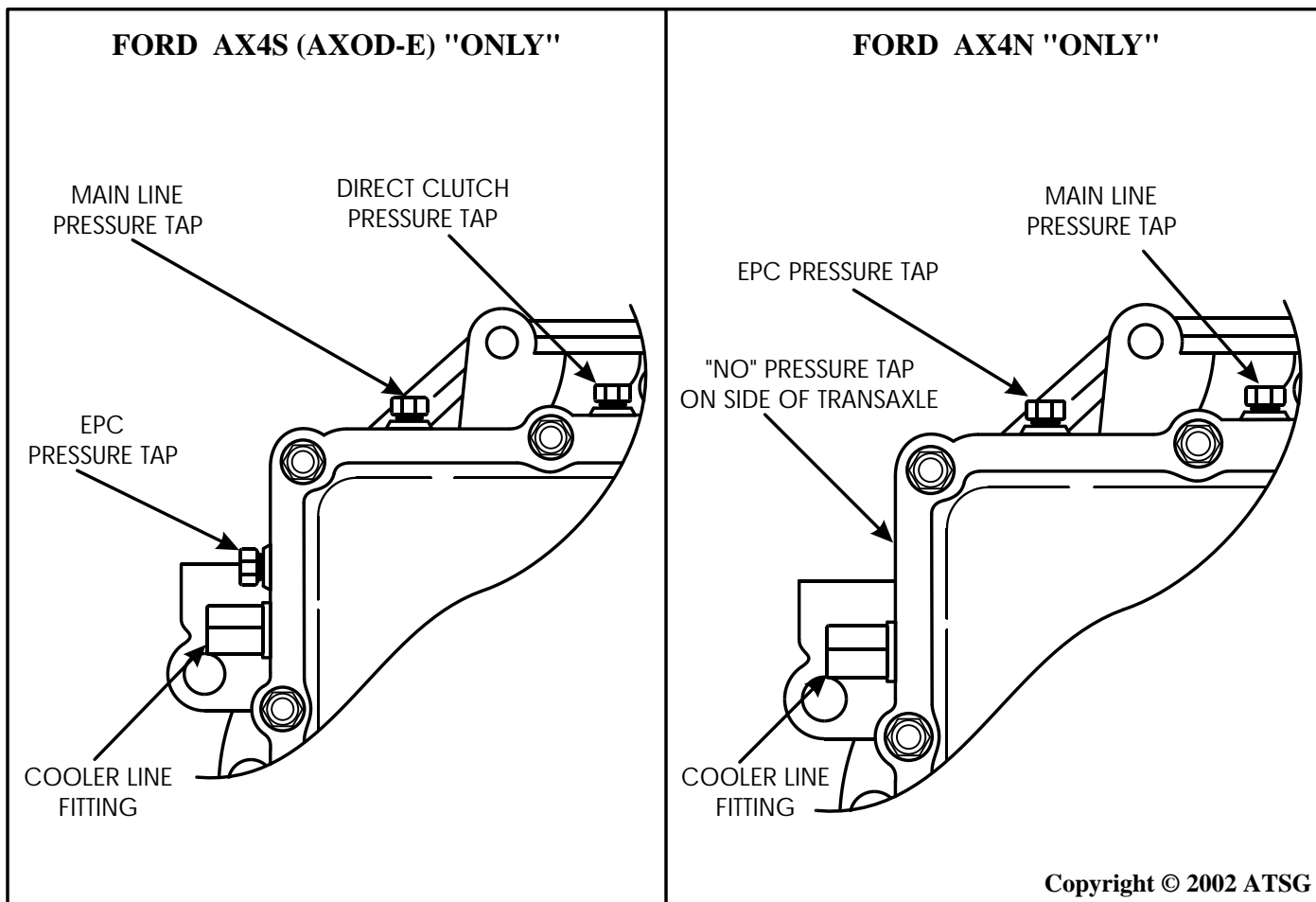

Figure 97



FORD AXODE (AX4S) PRESSURE CONTROL PROBLEM DIAGNOSIS

To accurately diagnose and repair pressure control problems, it first must be determined whether the problem is a malfunction that is inside the transaxle, or outside the transaxle. The pressure problems that we usually need to address and repair are high line, low line, and/or inadequate line rise, and fluctuations as seen on a pressure gauge while driving. One of the tools that can be used to determine inside transaxle or outside the transaxle, is the "Schaffer Shifter", or the "Tran X 2000". However, a current draw test in the EPC circuit can also be performed, while monitoring the pressure changes on a 0-400 lb. pressure gauge.

NOTE: It is very important to perform this test with a 0-400 lb (or higher) gauge as this transaxle is capable of producing over 400 PSI of line pressure, which could burst a gauge of a lower rating, and possibly cause injury.

A current draw test in the EPC circuit will also require the use of a Digital Volt-Ohm Meter, that is capable of reading Amps or Milliamps. When performing this test you will be looking at amperage changes in relation to pressure changes, as seen on the pressure gauge. With a normally functioning EPC circuit, you will see about **150 PSI** on the pressure gauge while in Park, **on the initial start up**, which is part of the computer strategy, **and is normal**. After the vehicle is warmed up and/or is put into gear the idle pressure will drop immediately to between 48 and 77 PSI. As the throttle is opened, the amperage should begin to drop, and the pressure should begin to rise.

To begin the EPC circuit current draw test, the EPC ground wire that runs from the computer to the transaxle case connector must be located, and the external wire color will be White with a Yellow tracer on both versions, as shown in Figure 98. On 1991-1992 model vehicles the wire will be found in the top case connector and comes from pin number 38 on the computer. On 1993-UP vehicles there is only one case connector and the wire still comes from pin number 38 on the computer. Refer to Figure 98.

Connect the 0-400 lb. pressure gauge to the mainline pressure tap, as shown in Figure 100. Cut the White wire with the Yellow tracer and hook the DVOM, **in series**, so that current flows **through** the DVOM, as shown in Figure 99. Start the engine and let it warm up until the pressure stabilizes between 48-77 PSI. The amperage reading at idle should be approximately 1 Amp. As the throttle is opened, amperage should begin to drop, and pressure should begin to rise. Refer to the chart in Figure 99.

If the amperage drops, but no pressure rise, the problem is inside the transaxle.

Problems on the inside of the transaxle will include, EPC Solenoid failure or trash in the solenoid, boost valve and/or sleeve damaged, pressure regulator valve damaged and/or sticking, blockage from gasket material (early models), pump damage and/or pump slide sticking.

If the amperage does not drop, and the pressure does not rise, the problem is outside the transaxle.

The inputs that are used by the computer to determine pressure changes will now have to be checked. These inputs include, Throttle Position Sensor, Mass Airflow Sensor, Power Steering Pressure Switch, Turbine Shaft Speed Sensor, Vehicle Speed Sensor. Bad harness connections and wiring damage must also be thoroughly checked and verified. After **all** sensors, connections and wiring have passed inspections and tested OK, the computer may have to be replaced.

When pressures are seen to be fluctuating on the gauge, but the amperage readings are steady, then the problems are on the inside of the transaxle.

If the pressures are seen to be fluctuating on the gauge, and the amperage readings are also fluctuating, then the problems are on the outside of the transaxle and are electrical.



TWO CASE CONNECTOR MODELS

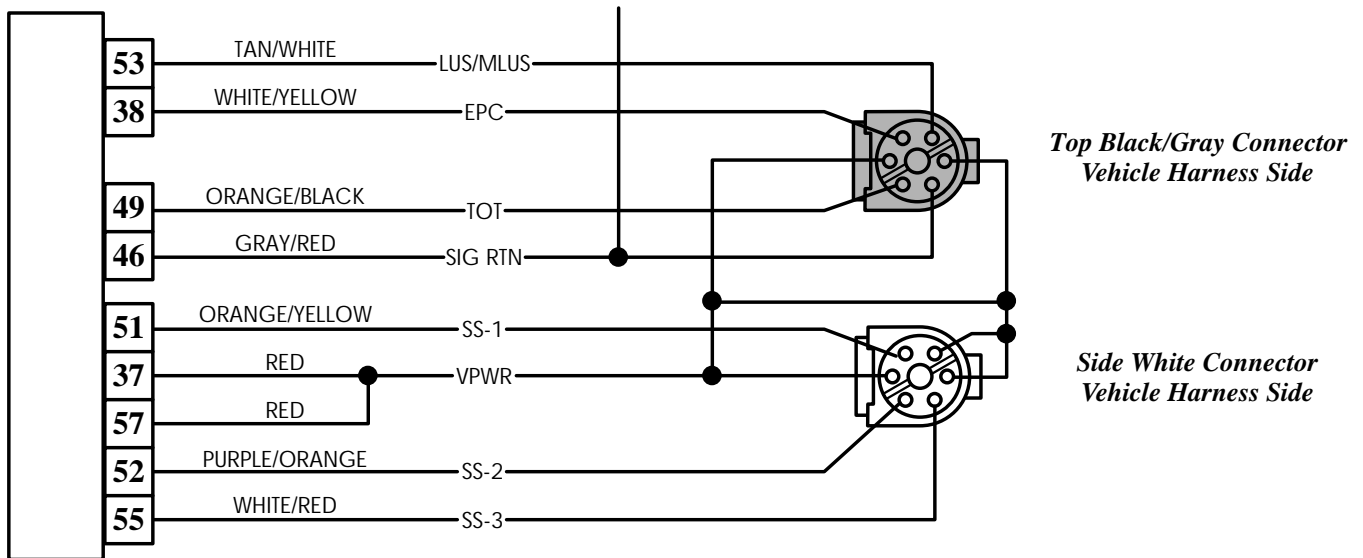

SINGLE 9 PIN CASE CONNECTOR MODELS

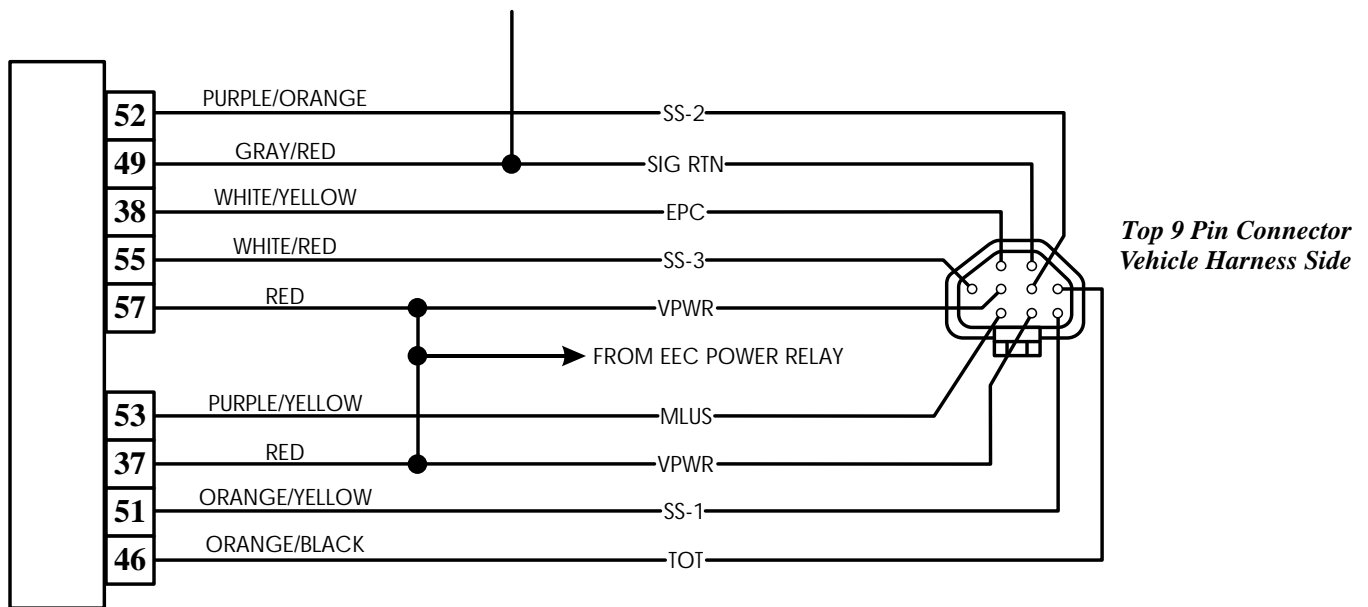

Copyright © 2002 ATSG

Figure 98



CONNECTING THE DVOM TO CHECK AMPS TO THE TRANSAXLE

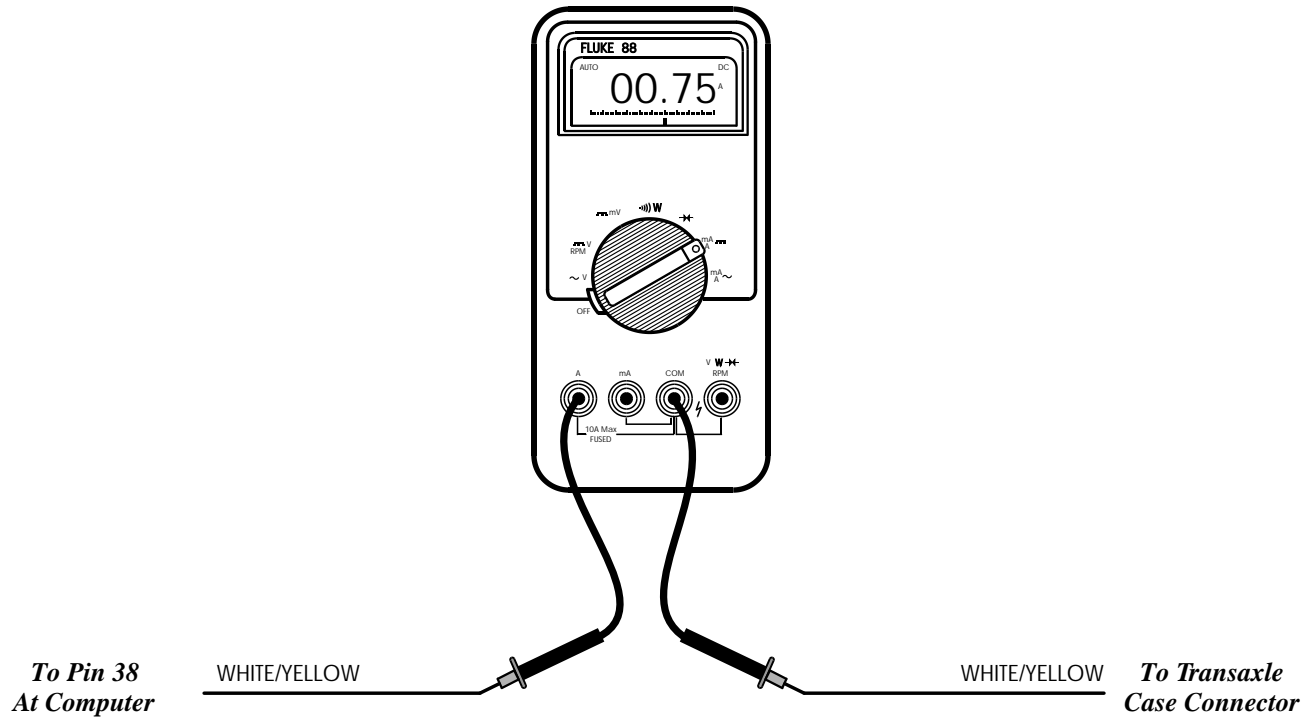

Cut the White/Yellow wire from Pin No. 38 at the computer and connect the DVOM leads, as shown above, to perform this test. This is known as "connecting in series".

EPC AMPS	1.0	.90	.75	.70	.60	.50	.35	
EPC PSI	20	30	40	50	60	70	80	
*P psi	75	----	----	----	----	----	----	
R psi	90	145	175	200	225	275	310	
N psi	75	----	----	----	----	----	----	
OD psi	75	100	125	145	165	180	210	
D psi	75	100	125	145	165	180	210	
L psi	80	100	125	155	175	190	220	

** With a normally functioning EPC circuit, you will see about 150 PSI on the pressure gauge while in Park, on "the initial start up", which is part of the computer strategy, "and is normal".*

Figure 99



PRESSURE TAP LOCATIONS

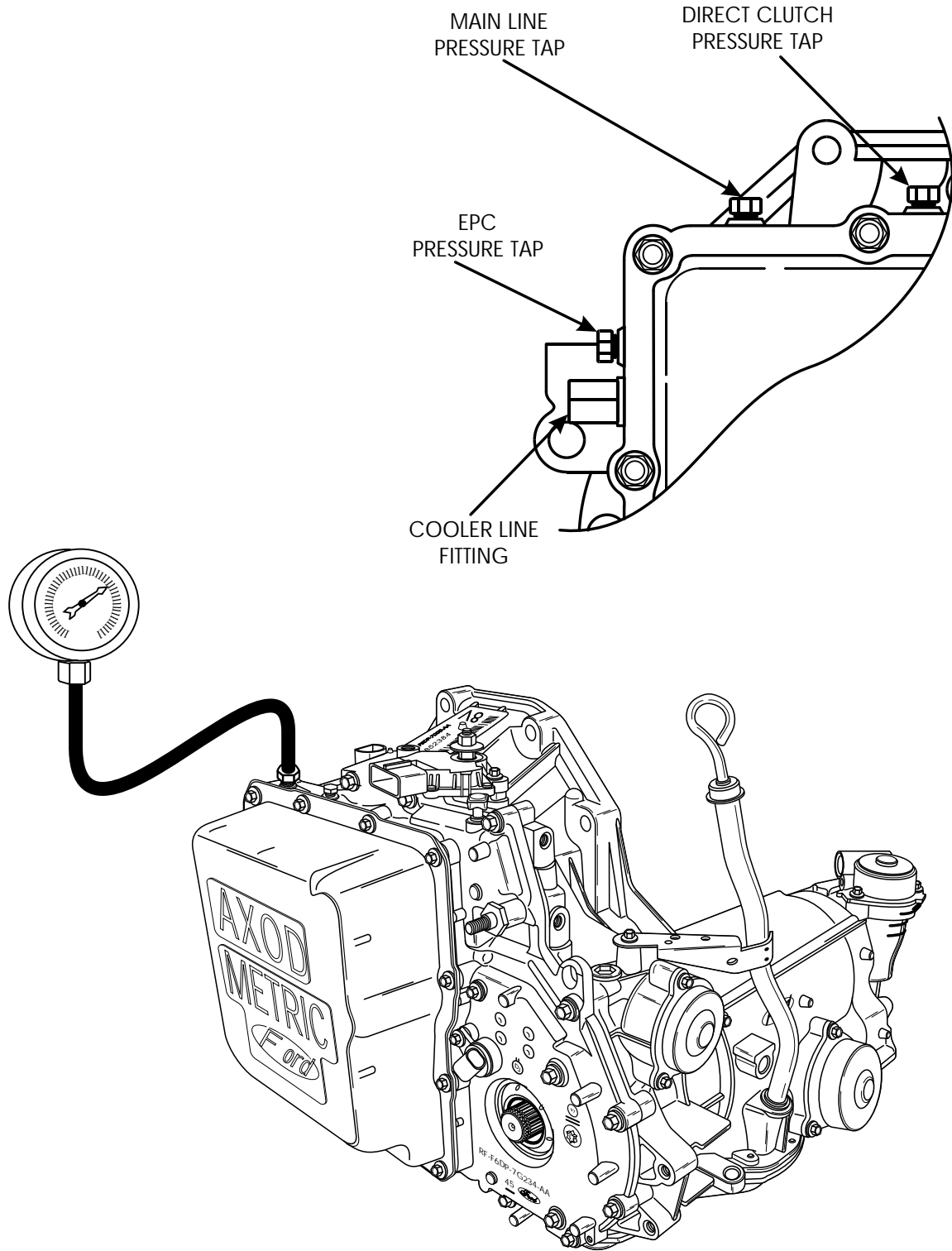

Copyright © 2002 ATSG

Figure 100

AUTOMATIC TRANSMISSION SERVICE GROUP



Technical Service Information

FORD AXODE (AX4S)

HARSH 1-2 UPSHIFT, OR FLARE ON 1-2 UPSHIFT

COMPLAINT: Some 1995-Up Ford Windstar Vans may exhibit a harsh 1-2 upshift, either before and/or after overhaul of the transaxle. Some 1995-Up Ford Taurus, Mercury Sable or Lincoln Continental may exhibit a soft or flare on the 1-2 upshift either before or after overhaul.

CAUSE: The cause may be, a valve body spacer plate designed for the Taurus, Sable, Continental passenger car family, has been installed on a Windstar Van, creating a harsh 1-2 upshift. If the Windstar Van valve body spacer plate, is installed on the Taurus, Sable, Continental family of vehicles, the result will be a soft or flared 1-2 upshift. ***Obviously these two spacer plates are different.*** Refer to Figures 101 and 102, using the two holes over the 1-2 capacity modulator valve area, for identification.

CORRECTION: Install the proper valve body spacer plate for the Ford family that you happen to be servicing at this time. Refer to the illustration in Figure 101 to identify the valve body spacer plate for the Windstar Van. Refer to the illustration in Figure 102 to identify the valve body spacer plate for the Taurus, Sable and Continental family.

Special Note: The valve bodies and castings are exactly the same in the 1-2 capacity modulator valve area, but the valve body casting and spacer plate changed again in 1999 in a different area (See Page 94). These same concerns may be encountered by changing a complete valve body, that included a spacer plate, trying to fix a totally different concern. Use Figures 101 and 102, using the two holes over the 1-2 capacity modulator valve area, to identify the valve body spacer plates.



"WINDSTAR" SPACER PLATE IDENTIFICATION

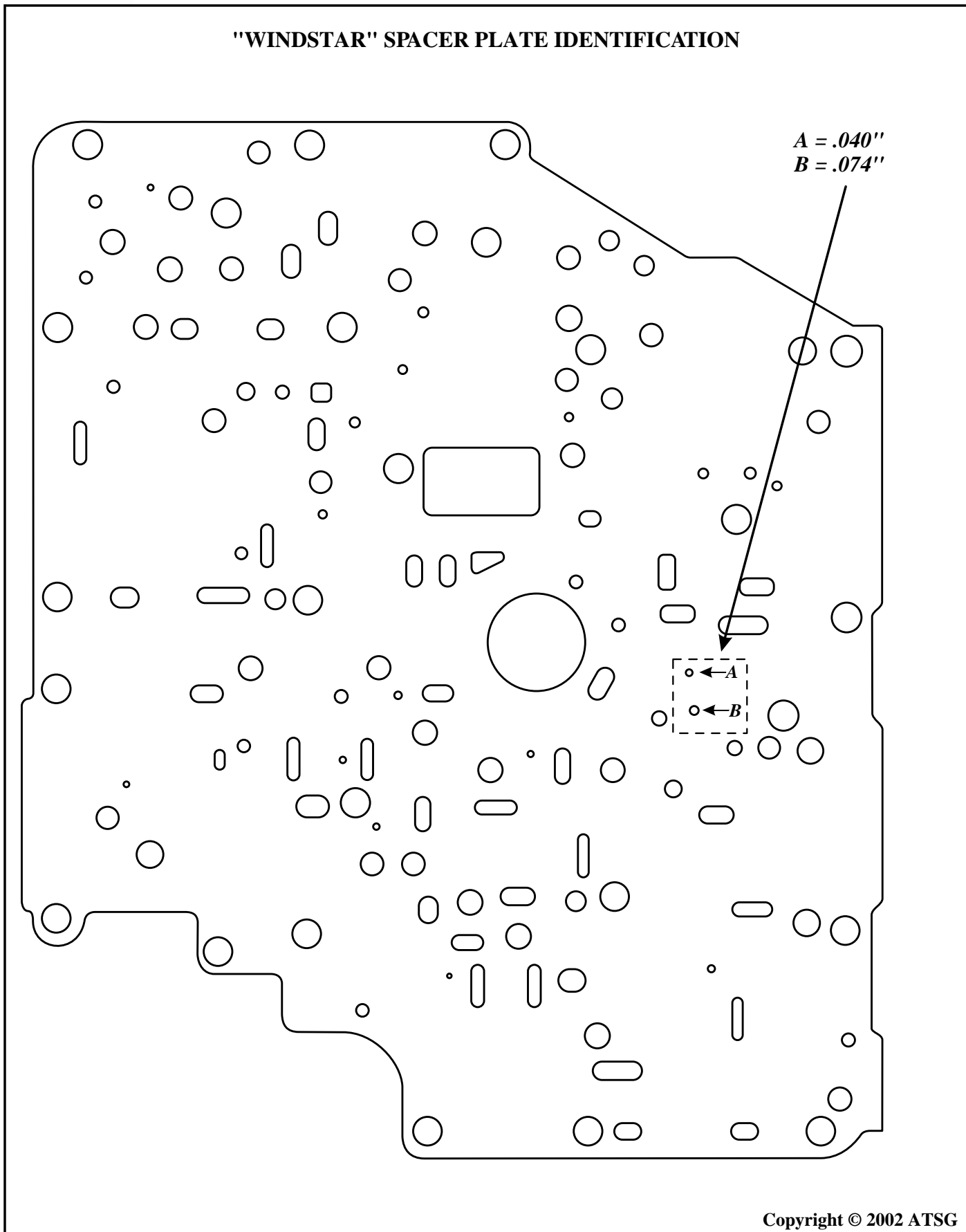

Copyright © 2002 ATSG

Figure 101

AUTOMATIC TRANSMISSION SERVICE GROUP



"TAURUS FAMILY" SPACER PLATE IDENTIFICATION

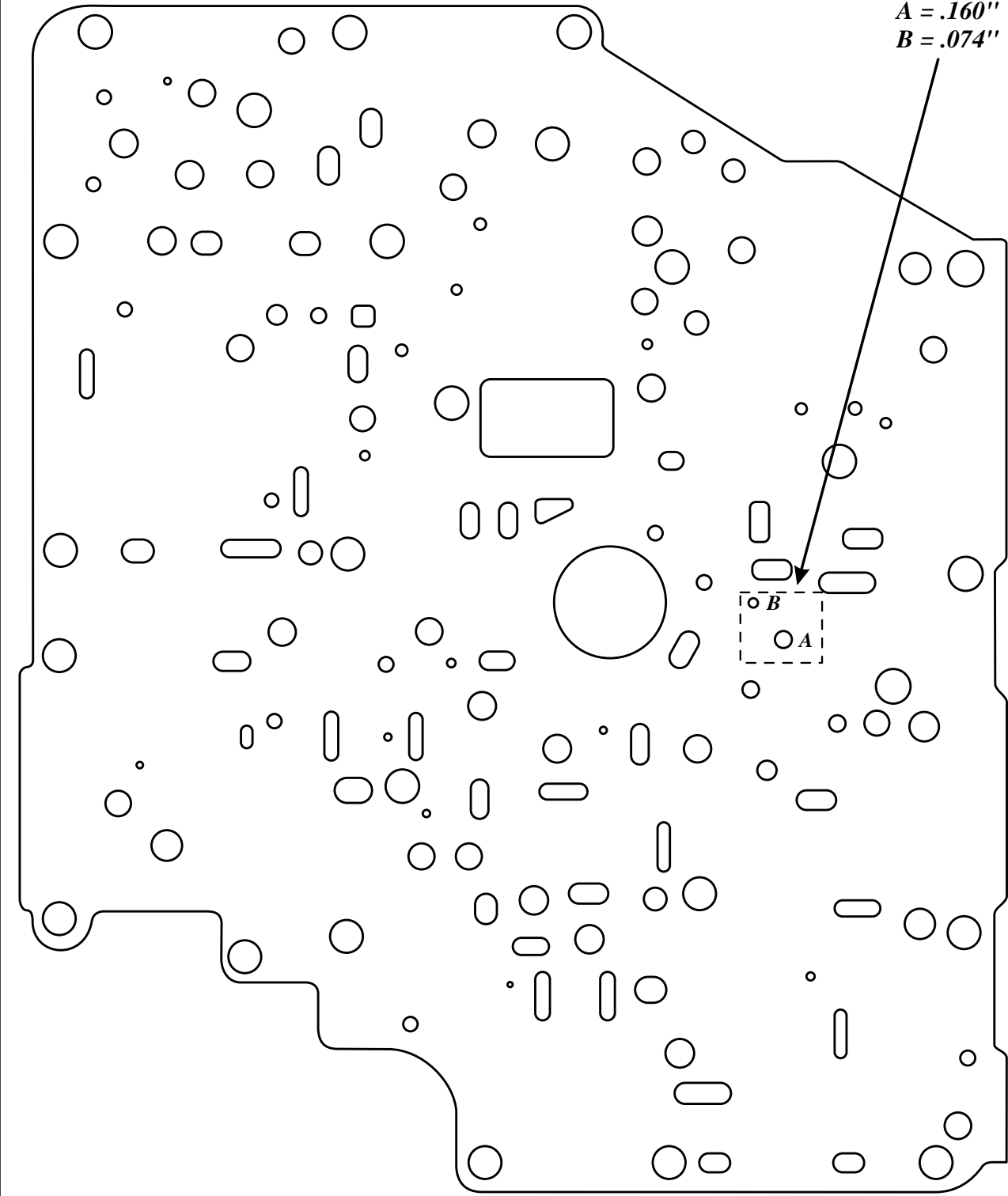

Copyright © 2002 ATSG

Figure 102

AUTOMATIC TRANSMISSION SERVICE GROUP



FORD AX4S/AX4N NO REVERSE

COMPLAINT: After overhaul, vehicles built after 1999, equipped with the AX4S or AX4N transmissions may exhibit a "no engagement" in Reverse.

CAUSE: The cause may be, that the *Previous Design* Channel Plate Gasket, was used on a *Late Design* case as shown in Figure 103. When this happens, Reverse apply pressure will be exhausted back into the case because of the gasket hanging over the case casting.

CORRECTION: AX4S-Refer to Figure 103 to identify the correct Channel Plate Gasket for the application of vehicle you are working on.
AX4N-Refer to Figure 104 to identify the correct Channel Plate Gasket for the application of vehicle you are working on.

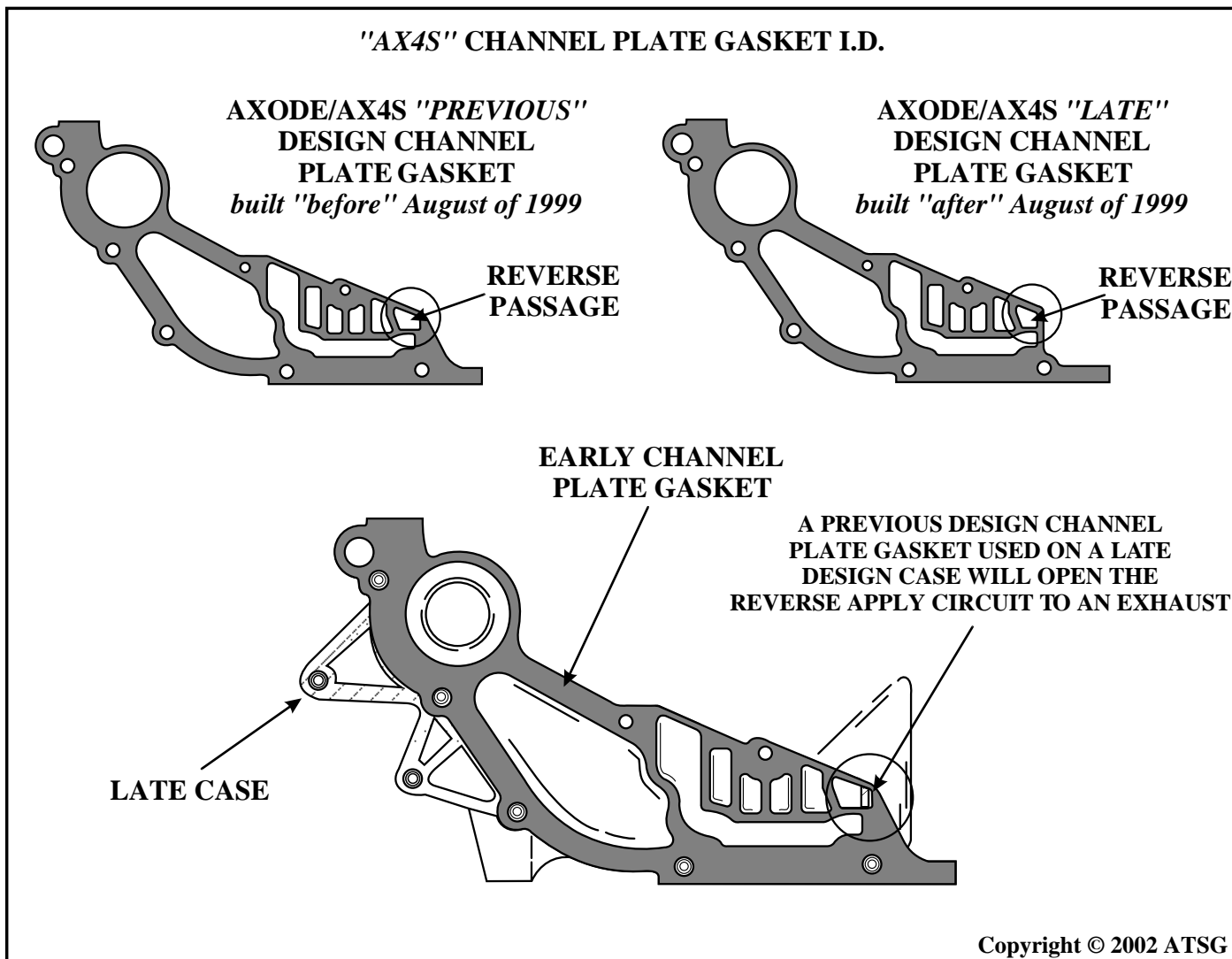
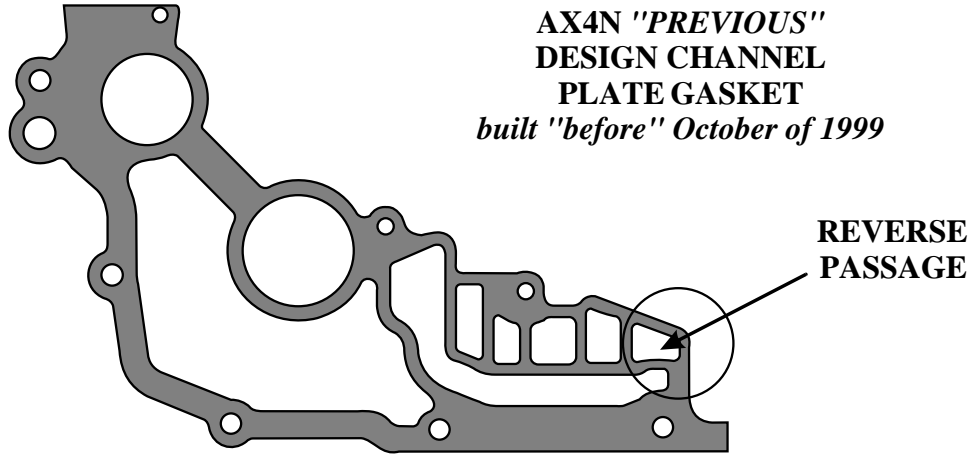

Figure 103



"AX4N" CHANNEL PLATE GASKET I.D.



"AX4N" CHANNEL PLATE GASKET I.D.

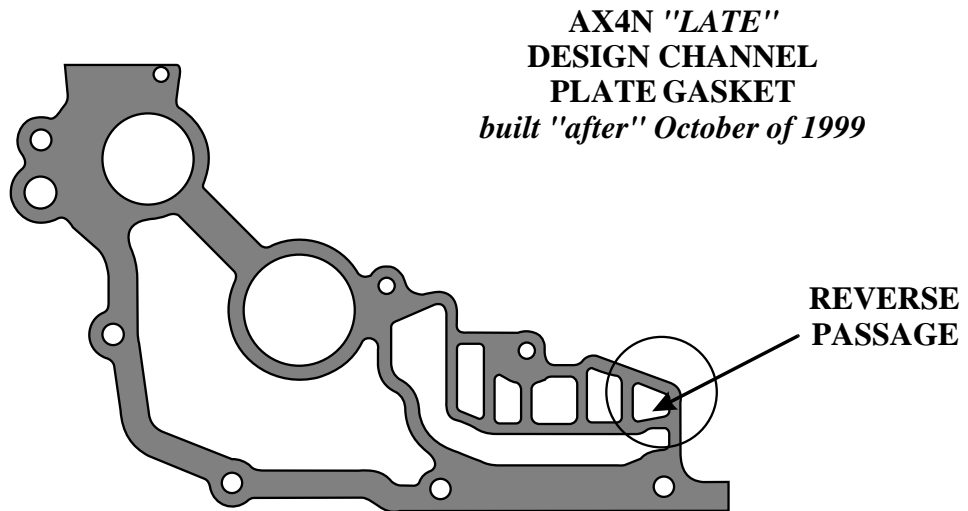

Copyright © 2000 ATSG

Figure 104