

A Closer Look at the Toyota A750E Valve Body

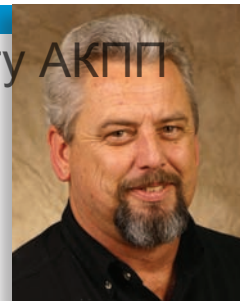

by Mike Brown
members.atra.com



| A750E (2WD)/A750F (4WD) Gear Ratios | |
|--|-------|
| 1st | 3.52 |
| 2nd | 2.042 |
| 3rd | 1.4 |
| 4th | 1 |
| 5th | 0.716 |
| Reverse | 3.224 |

Figure 1

The Toyota A750E was first introduced in the 2003 4-Runner and Land Cruiser, and the Lexus LX400 and GX470. Since then it's become quite popular, showing up in the Tacoma, Sequoia and Tundra in 2005 and the FJ Cruiser in 2007.

These transmissions have been on the road for up to seven years and are getting a lot of miles on them. With all the cars using this transmission, there's no doubt you'll be seeing it in the years to come (figure 1).

A common complaint is the transmission falling out of gear when coming to a stop, sometimes so harsh that it feels like someone has rear-ended you. This happens because the trans has fallen out of gear due to low pressure, caused by a faulty SLT pressure solenoid. The ECM then ramps up the pressure to max and it slams back into gear. Replace the SLT solenoid is the fix for this concern. But before we get into fixes let's learn a little about this unit

Line Pressure Specifications

Line pressure tap location and

A750E/F Line Pressure Specifications

| Condition | D Position | R Position |
|-----------|-------------|-------------|
| Idling | 53-59 psi | 73-84 psi |
| Stall | 196-212 psi | 188-205 psi |



Figure 2

specifications (figure 2).

ATF Temperature Sensor

This transmission uses two temperature sensors, each with a different function. The ECM uses ATF temperature sensor 1 to modify pressure control

for the clutches and brakes. If this sensor fails, the ECM will prevent upshifts into fifth gear and lockup. The ECM uses ATF temperature sensor 2 for shift timing control when ATF temperatures are high.

AKPPHELP.RU

Руководство по ремонту АКПП

MOST WANTED



**MERCEDES
722.9**



**VOLVO
AW55**

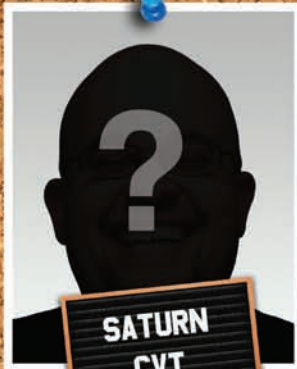

**SATURN
CVT**



**DODGE
68RFE**

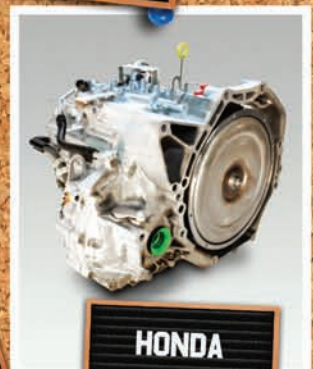

**HONDA
ACURA**



**INFINITI
RESROSA**



**VW
JF506E**



**LEXUS
U140**



**ZF
5HP**



**CADILLAC
SL40E**

**WHAT DO ALL THESE "TOUGH GUYS" HAVE IN COMMON?
ETE REMAN IS THE BOSS OF THEM ALL**



The **WIDEST** range of
REMANUFACTURED
TRANSMISSIONS
available anywhere



**CALL THE ETE REMAN
TIP LINE TODAY
866-717-9800
ETEREMAN.COM**

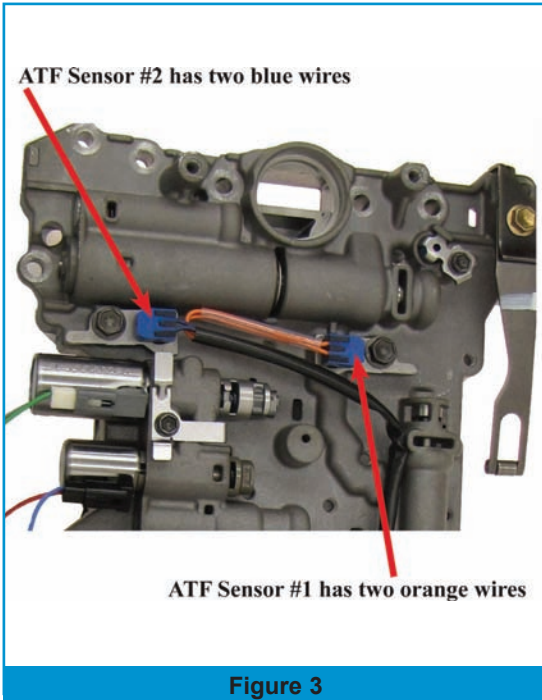

Figure 3



Figure 4

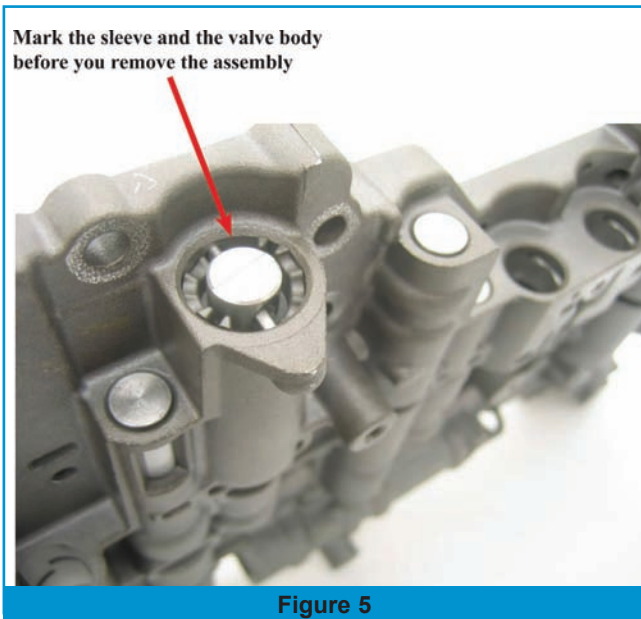

Figure 5

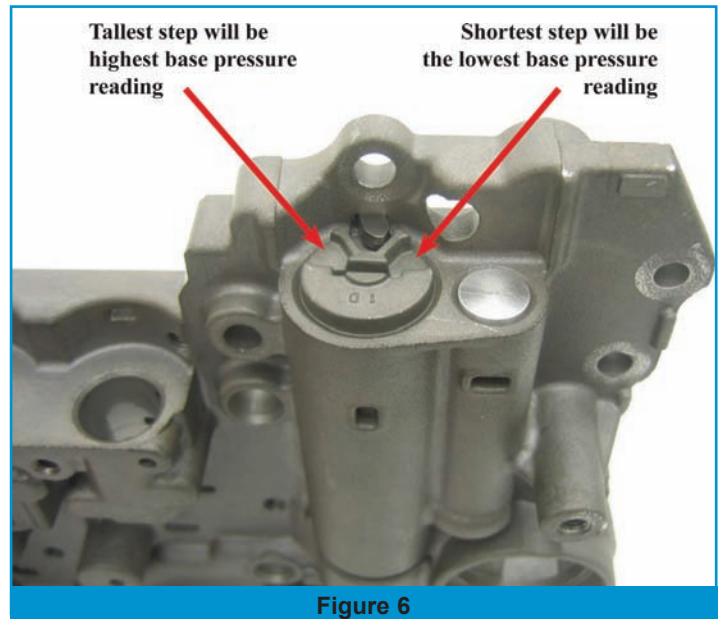

Figure 6

In some vehicles equipped with the A750E, the MIL may light intermittently, and the computer may store DTC P2742 in memory (Transmission fluid temperature sensor 2 circuit low).

To diagnose this, monitor ATF temperature sensor 2 and watch for it to short to ground intermittently. When the sensor shorts, ATF temperature sensor 2 will indicate 302°F (150°C). This is usually due to a faulty internal wiring harness; replacing the harness will correct the problem.

ATF temperature sensor 2 has two blue wires; ATF temperature sensor 1 has two orange wires (figure 3).

Solenoid ID and Location

This chart provides the repair manual ID for each solenoid in the A750E transmission, and the part name and description provided in the electronic parts catalog.

| ID | Solenoid Name | Parts Catalog Description |
|-----|-------------------------------|--------------------------------|
| S1 | Shift Solenoid A | 3-Way Transmission Solenoid |
| S2 | Shift Solenoid B | Transmission Solenoid 3 |
| SR | Shift Solenoid E | 3-Way Transmission Solenoid 2 |
| SL1 | Pressure Control Solenoid A | Clutch Control Solenoid 1 |
| SL2 | Pressure Control Solenoid B | Clutch Control Solenoid 2 |
| SLT | Pressure Control Solenoid D | Line Pressure Control Solenoid |
| SLU | TCC Pressure Control Solenoid | Lockup Control Solenoid |

Figure 4 shows the solenoid ID and location.

Valve Body Disassembly

There are a few procedures you should always keep in mind when

working the A750E valve body. Two things that you need to do are:

1. Make sure you record the accumulator control pressure setting prior to removing the accumulator control valve (figure 5).

COMMITMENT IS MORE THAN SKIN DEEP

Yeah, we're that
serious. When you see
the Transtar seal of
quality, you can trust that
when you build it once,
you've built it right.

You Can Count On Us.



Transtar Hard Parts.
Build it once. Build it right.

The Premier Provider of World Class Driveline Solutions.

TRANSTAR
TRANSTAR INDUSTRIES, INC.®

WWW.TRANSTAR1.COM • 1.800.359.3339



**TRANSTAR
HARD PARTS**

OEM / Aftermarket
Good Used / Remanufactured

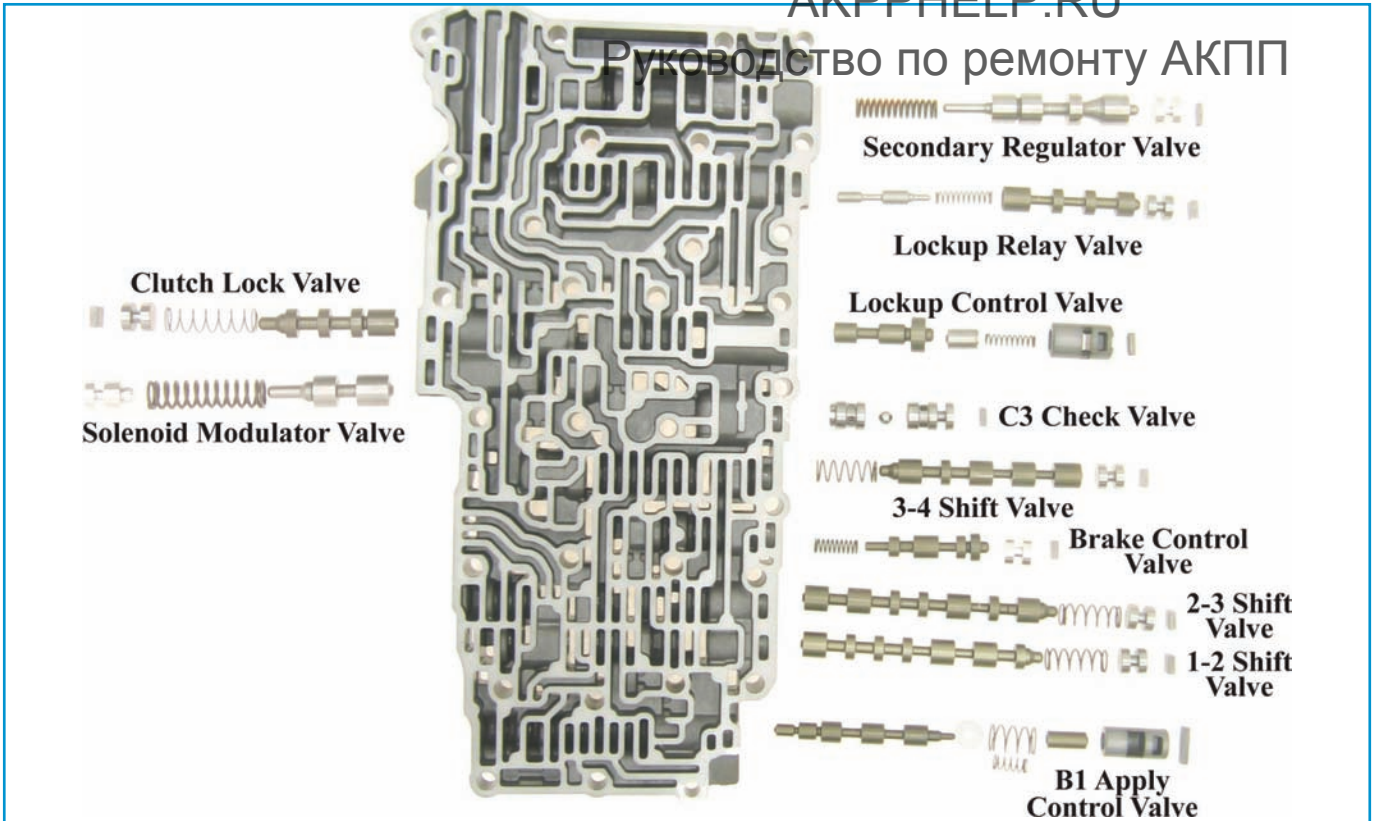

Figure 7

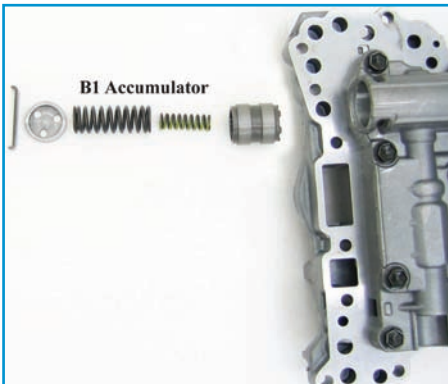

Figure 8

There's no factory preset specification. From the factory setting, you can turn the stepper in to provide a firmer shift feel. Backing the stepper out will offer a softer shift feel.

2. Make sure you record the primary regulator valve setting before removing primary regulator valve from the valve body. The tallest step will provide the highest base pressure reading; the shortest step will provide the lowest base pressure reading (figure 6).

Always inspect the valves and springs thoroughly during disassembly. Check the valves for scoring and make sure the valve bore is clean. Pay close attention to the valve layout, and make sure you put them back in the way they came out.

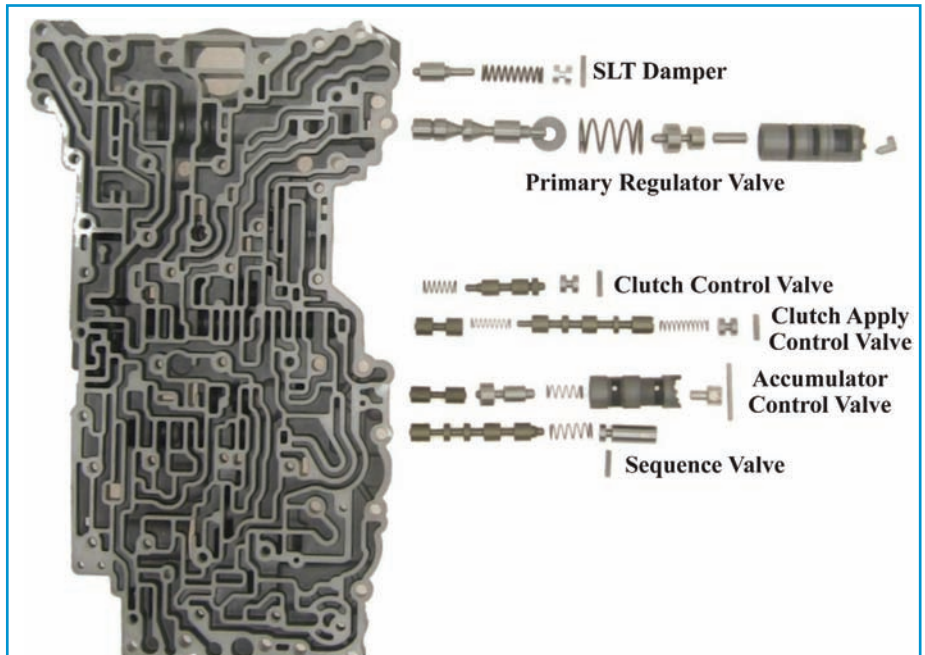

Figure 9

Exploded View Upper Valve Body I

Install the checkball in the C3 check valve lineup (figure 7). If you leave this checkball out, the transmission won't go into reverse.

Always check the B1 accumulator in the upper valve body (figure 8). This is where debris will build up. It can be difficult to remove, but it's important

to take it out and clean the bore thoroughly.

Exploded View Lower Valve Body I

The primary regulator valve and the accumulator control valve are located in the lower valve body (figure 9). Record the settings for these valves.

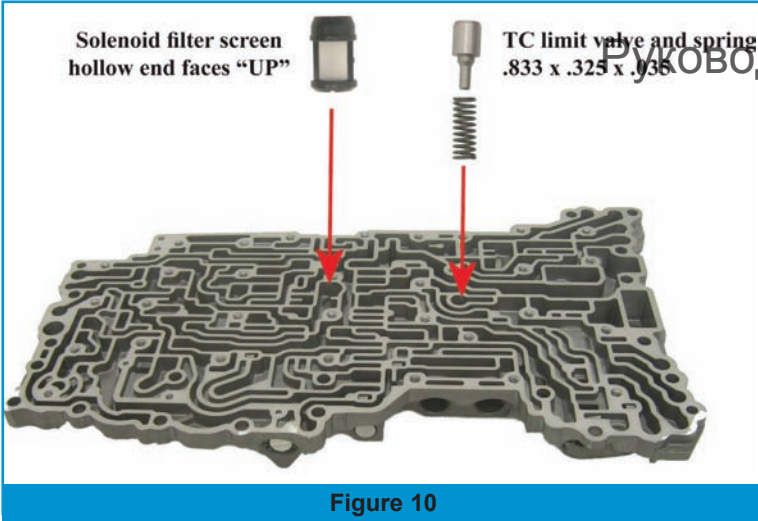

Figure 10

Once you've recorded the settings, disassemble the lower valve body, check the valves for scoring, and make sure the valve bore is clean.

Always install the solenoid filter screen (figure 10) with the open end up. The screen will snap into the separator plate when properly installed. Install the torque converter check valve as shown.

Upper Valve Body 1 and 2 Checkballs

There are three sections to the A750E/F valve body. Upper valve bodies 1 and 2 are the only valve bodies with checkballs (figures 11 and 12).

All of the checkballs are composite. Make sure the checkballs are in good shape; replace any that are damaged or have decomposed. All of the checkballs are the same size: 0.217" (5.5mm).

The coast brake relay valve is located in upper valve body 2 (figure 12). Be sure to remove, clean and inspect this valve body.

Lower Valve Body 1

The purpose of the pressure limit checkball is to exhaust pressure if it becomes too high (figure 13). The limit valve will blow off at about 300 PSI.

Now that we've covered all solenoids, control valves and checkballs in the valve body, reassembling the valve body should be a snap.

The A750E valve body isn't difficult to work with. But without the proper information and understanding, you could easily cause yourself problems later on. That's why it's so important to have all the information close at hand. It's not just smart... it's *Street Smart!*

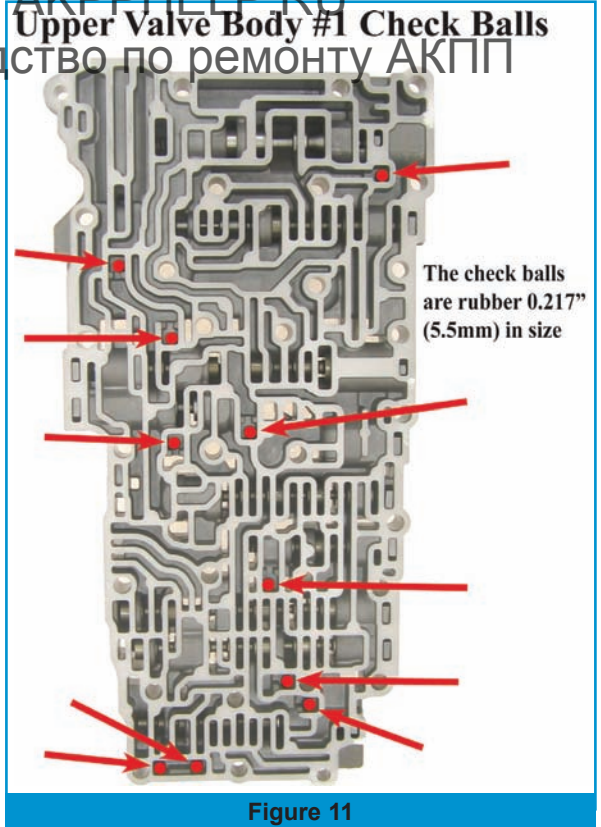

Figure 11

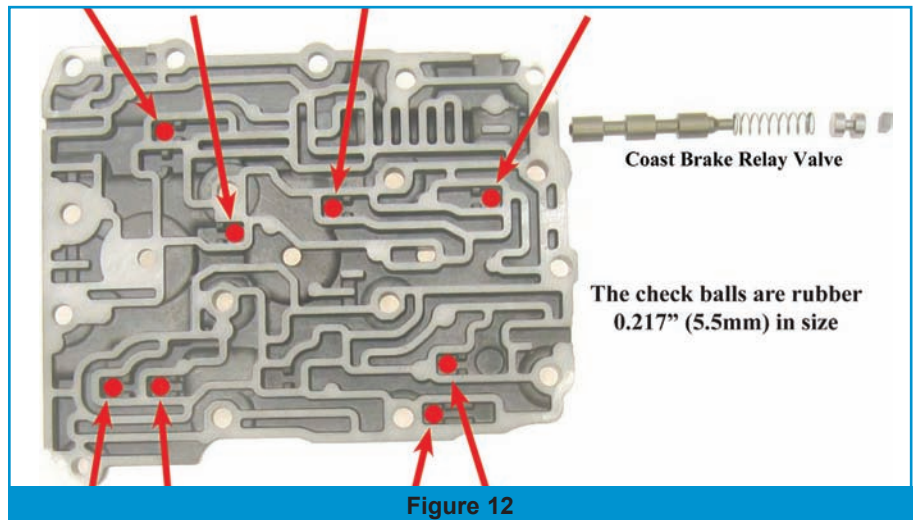

Figure 12

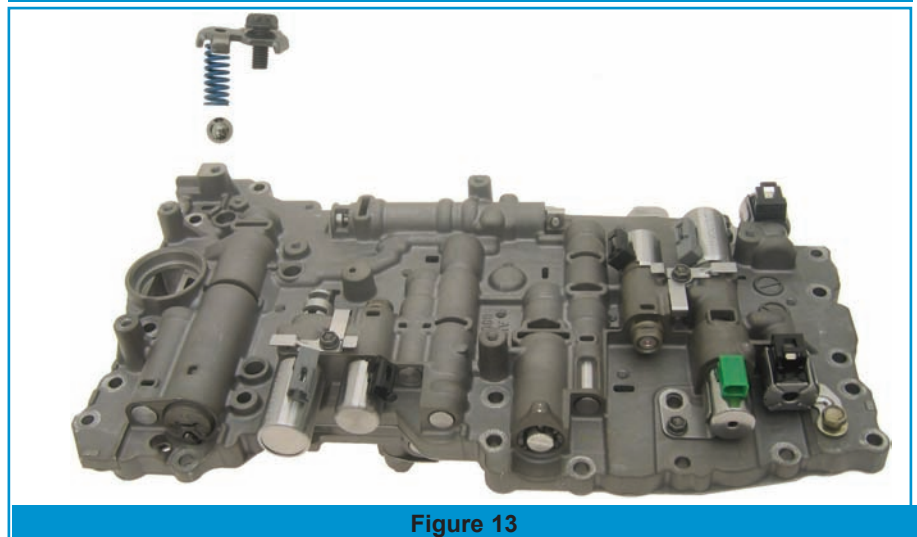

Figure 13